

MUPR-H16

Engineering data book

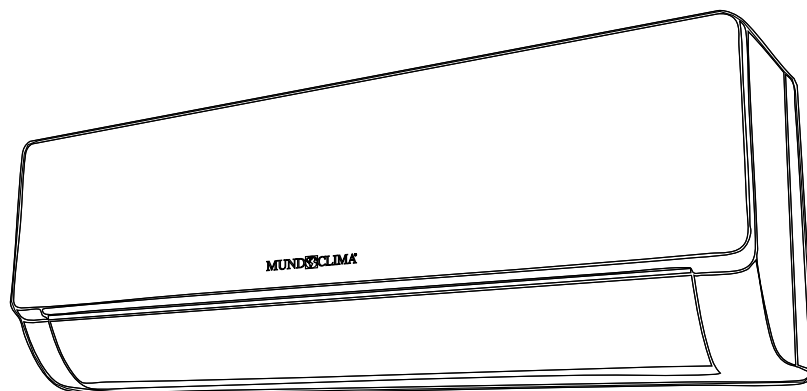

CL20066 - CL20069
UI20066 - UI20063

English



Table of Contents

Page

1. Specifications.....	3
1.1 Technical Specifications	3
1.2 Electrical Characteristics	11
2. Capacity Tables	12
2.1 Cooling.....	12
2.2 Heating.....	16
3. Capacity Correction Factor for Height Difference	19
4. Dimensional Drawings & Centre of gravity	22
4.1 Dimensional Drawings	22
4.2 Centre of gravity	26
5. Electrical Wiring Diagrams	28
5.1 Indoor unit.....	28
5.2 Outdoor Unit	29
6. Refrigerant Cycle Diagrams	30
7. Noise Criterion Curves	32
7.1 Indoor Unit	32
7.2 Outdoor Unit	35
8. Air Velocity and Temperature Distributions	37

1. Specifications

1.1 Technical Specifications

Model		None	MUPR-09-H16	
Power supply	V- Ph-Hz	220-240-1-50	220-240-1-50	
Rated Power Input	W	2030	2200	
Rated Current	A	9	10	
Compressor	Model	KSK75D32UEZD31	KSN98D13UEZ32	
	Type	ROTARY	ROTARY	
	Brand	GMCC	GMCC	
	Capacity	W	1470/2335	1915/3050
	Input	W	235/605	310/800
	Rated current(RLA)	A	1.68/3.95	2.35/4.95
	Locked rotor Amp(LRA)	A	/	/
	Thermal protector		/	/
	Thermal protector position		/	/
	Capacitor	uF	/	/
	Refrigerant oil/oil charge	ml	VG74 240	POE VG74 280
Indoor fan motor	Model	ZKFP-31-8-1L	ZKFP-31-8-1L	
	Input	W	48.6	
	Output	W	31	
	Insulation class		B	
	Waterproofing class		IP20	
	Capacitor	uF	/	
	Speed(Hi/Mi/Lo)	r/min	1050/930/870	1150/990/910
Indoor coil	Number of rows		1	
	Tube pitch(a)x row pitch(b)	mm	18x17.3	
	Fin spacing	mm	1.3	
	Fin type (code)		Hydrophilic aluminium	
	Tube outside dia.and type	mm	Φ5,inner groove tube	
	Coil length x height x width	mm	530x72x17.3+530x108x17.3+530x108x17.3	
	Number of circuits		2	
Indoor side air flow(Si/Lo/Mi/Hi/SH)	m3/h	140/300/360/490/570	140/300/380/510/580	
Indoor noise level (Turbo/Hi/Mi/Lo/Si)	dB(A)	44/38/32/23/18	46/38/33/24/19	
Indoor sound power level	dB(A)	54	54	
Indoor unit	Dimension(W*D*H)	mm	723x199x286	
	Packing (W*D*H)	mm	780x270x365	
	Net/Gross weight	kg	6.9/9.1	
Outdoor fan motor	Model	ZKFN-25-10-6L	ZKFN-25-10-6L	
	Input	W	55.5	
	Output	W	25	
	Insulation class		B	
	Waterproofing class		IP24	
	Capacitor	uF	/	
	Speed	r/min	850/650	800/700/600

Outdoor coil	Number of rows		1	1
	Tube pitch(a)x row pitch(b)	mm	18x17.3	18x17.3
	Fin spacing	mm	1.3	1.3
	Fin type (code)		Hydrophilic aluminum	Hydrophilic aluminum
	Tube outside dia.and type	mm	Φ5,inner groove tube	Φ5,inner groove tube
	Coil length x height x width	mm	595x432x17.3	695x468x17.3
	Number of circuits		2	3
Outdoor air flow		m3/h	1300	1750
Outdoor sound pressure level		dB(A)	51.5	54.5
Outdoor sound power level		dB(A)	59.0	62
Outdoor unit	Dimension(W*D*H)	mm	668x252x469	720x270x495
	Packing (W*D*H)	mm	765x270x525	835x300x540
	Net/Gross weight	kg	17.8/19.5	20.4/22.3
Refrigerant	Type		R32	R32
	GWP		675	675
	Charged quantity	kg	0.4	0.46
Design pressure		MPa	4.3/1.7	4.3/1.7
Refrigerant piping	Liquid side/ Gas side	mm (inch)	Φ6.35/Φ9.52(1/4"/3/8")	Φ6.35/Φ9.52(1/4"/3/8")
	Max. refrigerant pipe length	m	25	25
	Max. difference in level	m	10	10
Connection wiring			5x1.5	5x1.5
Plug type			3x1.5 / no-plug	3x1.5 / no-plug
Thermostat type			Remote Control	Remote Control
Operation temperature			16-32	16-32
Ambient temperature	Indoor(cooling/ heating)	°C	16~32/0~30	16~32/0~30
	Outdoor(cooling/heating)	°C	-15~50/-20~24	-15~50/-20~24
Qty'per 20' /40' /40'HQ			155/320/365	140/290/320

Notes:

1) Capacities are based on the following conditions:

Cooling(T1): - Indoor Temperature 27°C(80.6°F) DB /19 °C(66.2°F) WB
 -Outdoor Temperature 35 °C(95°F) DB /24 °C(75.2°F) WB
 -Interconnecting Piping Length 5m
 - Level Difference of Zero.

Heating: - Indoor Temperature 20°C(68°F) DB / 15°C(59°F) WB
 -Outdoor Temperature 7°C(44.6°F) DB / 6°C(42.8°F) WB
 - Interconnecting Piping Length 5 m
 - Level Difference of Zero.

2) Capacities are Net Capacities.

3) Due to our policy of innovation some specifications may be changed without notification.

Model		None	None	
Power supply	V- Ph-Hz	220-240-1-50	220-240-1-50	
Rated Power Input	W	2,200	2,200	
Rated Current	A	10.0	10.0	
Compressor	Model	KSN98D13UEZ32	KSN98D13UEZ32	
	Type	ROTARY	ROTARY	
	Brand	GMCC	GMCC	
	Capacity	W	1915/3050	1915/3050
	Input	W	310/800	310/800
	Rated current(RLA)	A	2.35/4.95	2.35/4.95
	Locked rotor Amp(LRA)	A	/	/
	Thermal protector		/	/
	Thermal protector position		NA	NA
	Capacitor	uF	/	/
	Refrigerant oil/oil charge	ml	POE VG74 280	POE VG74 280
Indoor fan motor	Model	ZKFP-30-8-357L	ZKFP-31-8-1L	
	Input	W	42.9	48.6
	Output	W	35	31
	Insulation class		B	B
	Waterproofing class		IP20	IP20
	Capacitor	uF	/	/
	Speed(Hi/Mi/Lo)	r/min	1050/930/870	1100/940/860
Indoor coil	Number of rows		2	2
	Tube pitch(a)x row pitch(b)	mm	19.5x11.6	19.5x11.6
	Fin spacing	mm	1.3	1.3
	Fin type (code)		Hydrophilic aluminium	Hydrophilic aluminium
	Tube outside dia.and type	mm	Φ5,inner groove tube	Φ5,inner groove tube
	Coil length x height x width	mm	530x195x23.2+530x97.5x23.2	620x72x17.3+620x117x23.2+620x108x17.3
	Number of circuits		3	3
Indoor Indoor side air flow(Si/Lo/Mi/Hi/SH)	m3/h	150/285/360/510/650	170/340/420/600/690	
Indoor noise level (Turbo/Hi/Mi/Lo/Si)	dB(A)	45/38/34/24/20	47/40/34/24/20	
Indoor sound power level	dB(A)	54	54	
Indoor unit	Dimension(W*D*H)	mm	723x199x286	813x201x289
	Packing (W*D*H)	mm	780x270x365	870x270x365
	Net/Gross weight	kg	7.5/9.6	7.575/9.975
Outdoor fan motor	Model	ZKFN-25-10-6L	ZKFN-25-10-6L	
	Input	W	55.5	55.5
	Output	W	25	25
	Insulation class		B	B
	Waterproofing class		IP24	IP24
	Capacitor	uF	/	/
	Speed	r/min	800/700/600	800/700/600

Outdoor coil	Number of rows		1	1
	Tube pitch(a)x row pitch(b)	mm	18x17.3	21x22
	Fin spacing	mm	1.3	1.3
	Fin type (code)		Hydrophilic aluminum	Hydrophilic aluminum
	Tube outside dia.and type	mm	Φ5,inner groove tube	Φ7,inner groove tube
	Coil length x height x width	mm	695x468x17.3	740x462x22
	Number of circuits		3	2
Outdoor air flow		m ³ /h	1750	1750
Outdoor sound pressure level		dB(A)	54	55
Outdoor sound power level		dB(A)	59	63
Outdoor unit	Dimension(W*D*H)	mm	720x270x495	720x270x495
	Packing (W*D*H)	mm	835x300x540	835x300x540
	Net/Gross weight	kg	20.5/22.4	21.1/23
Refrigerant	Type		R32	R32
	GWP		675	675
	Charged quantity	kg	0.46	0.58
Design pressure		MPa	4.3/1.7	4.3/1.7
Refrigerant piping	Liquid side/ Gas side	mm (inch)	Φ6.35/Φ9.52(1/4"/3/8")	Φ6.35/Φ9.52(1/4"/3/8")
	Max. refrigerant pipe length	m	25	25
	Max. difference in level	m	10	10
Connection wiring			1.5x5	1.5x5
Plug type			no-plug	no-plug
Thermostat type			Remote Control	Remote Control
Operation temperature			16-32	16-32
Ambient temperature	Indoor(cooling/ heating)	°C	16~32/0~30	16~32/0~30
	Outdoor(cooling/heating)	°C	-15~50/-20~24	-15~50/-20~24
Qty'per 20' /40' /40'HQ			140/290/320	130/275/310

Notes:

1) Capacities are based on the following conditions:

Cooling(T1): - Indoor Temperature 27°C(80.6°F) DB /19 °C(66.2°F) WB
 -Outdoor Temperature 35 °C(95°F) DB /24 °C(75.2°F) WB
 -Interconnecting Piping Length 5m
 - Level Difference of Zero.

Heating: - Indoor Temperature 20°C(68°F) DB / 15°C(59°F) WB
 -Outdoor Temperature 7°C(44.6°F) DB / 6°C(42.8°F) WB
 - Interconnecting Piping Length 5 m
 - Level Difference of Zero.

2) Capacities are Net Capacities.

3) Due to our policy of innovation some specifications may be changed without notification.

Model		None	MUPR-12-H16	
Power supply	V- Ph-Hz	220-240-1-50	220-240-1-50	
Rated Power Input	W	2200	2200	
Rated Current	A	10	10	
Compressor	Model	KSN98D13UEZ32	KSN98D13UEZ32	
	Type	ROTARY	ROTARY	
	Brand	GMCC	GMCC	
	Capacity	W	1915/3050	1915/3050
	Input	W	310/800	310/800
	Rated current(RLA)	A	2.35/4.95	2.35/4.95
	Locked rotor Amp(LRA)	A	/	/
	Thermal protector		/	/
	Thermal protector position		/	/
	Capacitor	uF	/	/
	Refrigerant oil/oil charge	ml	POE VG74 280	POE VG74 280
Indoor fan motor	Model	ZKFN-25-10-6L	ZKFN-25-10-6L	
	Input	W	48.6	48.6
	Output	W	25	25
	Insulation class		B	B
	Waterproofing class		IP20	IP20
	Capacitor	uF	/	/
	Speed(Hi/Mi/Lo)	r/min	1000/880/820	1020/890/820
Indoor coil	Number of rows		2	1
	Tube pitch(a)x row pitch(b)	mm	19.5x11.6	18x17.3
	Fin spacing	mm	1.3	1.3
	Fin type (code)		Hydrophilic aluminium	Hydrophilic aluminium
	Tube outside dia.and type	mm	Φ5,inner groove tube	Φ7,inner groove tube
	Coil length x height x width	mm	620x195x23.2+ 620x97.5x23.2	620x72x17.3+620x108x23.2+620 x108x17.3
	Number of circuits		3	2
Indoor side air flow(Si/Lo/Mi/Hi/SH)	m3/h	220/370/450/600/800	190/340/420/590/740	
Indoor noise level (Turbo/Hi/Mi/Lo/Si)	dB(A)	43/36/28/21.5	46/39.5/32.5/21.5	
Indoor sound power level	dB(A)	58	56	
Indoor unit	Dimension(W*D*H)	mm	813x201x289	813x201x289
	Packing (W*D*H)	mm	870x270x365	870x270x365
	Net/Gross weight	kg	8/10.3	7.4/9.7
Outdoor fan motor	Model	ZKFN-25-10-6L	ZKFN-25-10-6L	
	Input	W	55.5	55.5
	Output	W	25	25
	Insulation class		B	B
	Waterproofing class		IP24	IP24
	Capacitor	uF	/	/
	Speed	r/min	800/700/600	810/700/600

Outdoor coil	Number of rows		1	1
	Tube pitch(a)x row pitch(b)	mm	21x22	18x17.3
	Fin spacing	mm	1.3	1.3
	Fin type (code)		Hydrophilic aluminum	Hydrophilic aluminum
	Tube outside dia.and type	mm	Φ7,inner groove tube	Φ5,inner groove tube
	Coil length x height x width	mm	740x462x22	695x468x17.3
	Number of circuits		2	3
Outdoor air flow		m ³ /h	1750	1750
Outdoor sound pressure level		dB(A)	56	56
Outdoor sound power level		dB(A)	62	62.5
Outdoor unit	Dimension(W*D*H)	mm	720x270x495	720x270x495
	Packing (W*D*H)	mm	835x300x540	835x300x540
	Net/Gross weight	kg	21.1/23	20.4/22.3
Refrigerant	Type		R32	R32
	GWP		675	675
	Charged quantity	kg	0.58	0.49
Design pressure		MPa	4.3/1.7	4.3/1.7
Refrigerant piping	Liquid side/ Gas side	mm (inch)	Φ6.35/Φ9.52(1/4"/3/8")	Φ6.35/Φ9.52(1/4"/3/8")
	Max. refrigerant pipe length	m	25	25
	Max. difference in level	m	10	10
Connection wiring			5x1.5	5x2.5
Plug type			3x1.5 / no-plug	3x1.5 / no-plug
Thermostat type			Remote Control	Remote Control
Operation temperature			16-32	16-32
Ambient temperature	Indoor(cooling/ heating)	°C	16~32/0~30	16~32/0~30
	Outdoor(cooling/heating)	°C	-15~50/-20~24	-15~50/-20~24
Qty'per 20' /40' /40'HQ			130/275/310	130/275/310

Notes:

1) Capacities are based on the following conditions:

Cooling(T1): - Indoor Temperature 27°C(80.6°F) DB /19 °C(66.2°F) WB
 -Outdoor Temperature 35 °C(95°F) DB /24 °C(75.2°F) WB
 -Interconnecting Piping Length 5m
 - Level Difference of Zero.

Heating: - Indoor Temperature 20°C(68°F) DB / 15°C(59°F) WB
 -Outdoor Temperature 7°C(44.6°F) DB / 6°C(42.8°F) WB
 - Interconnecting Piping Length 5 m
 - Level Difference of Zero.

2) Capacities are Net Capacities.

3) Due to our policy of innovation some specifications may be changed without notification.

Model		MUPR-18-H16	MUPR-24-H16	
Power supply	V- Ph-Hz	220-240-1-50	220-240-1-50	
Rated Power Input	W	2,800	3,900	
Rated Current	A	13	19	
Compressor	Model	KSN140D33UFZB3	KTM29000D27UKT3	
	Type	ROTARY	TWIN-ROTARY	
	Brand	GMCC	GMCC	
	Capacity	W	2690/4350	4505/7270
	Input	W	434/1127	767/1980
	Rated current(RLA)	A	3.18/6.9	4.15/9.15
	Locked rotor Amp(LRA)	A	/	/
	Thermal protector		/	/
	Thermal protector position		NA	NA
	Capacitor	uF	/	/
	Refrigerant oil/oil charge	ml	ESTER OIL VG74 440	POE VG74 500
Indoor fan motor	Model	ZKFP-35-10-188L	ZKFP-58-8-26L	
	Input	W	55	88
	Output	W	35	58
	Insulation class		B	B
	Waterproofing class		IP20	IP20
	Capacitor	uF	/	/
	Speed(Hi/Mi/Lo)	r/min	1000/868/802	1050/910/840
Indoor coil	Number of rows		2	2
	Tube pitch(a)x row pitch(b)	mm	19.5x11.6	19.5x11.6
	Fin spacing	mm	1.3	1.3
	Fin type (code)		Hydrophilic aluminium	Hydrophilic aluminium
	Tube outside dia.and type	mm	Φ5,inner groove tube	Φ5,inner groove tube
	Coil length x height x width	mm	770x195x23.2+770x117x23.2	820x214.5x23.2+820x117x23.2
	Number of circuits		4	6
Indoor Indoor side air flow(Si/Lo/Mi/Hi/SH)	m3/h	340/470/600/800/950	400/600/750/1050/1400	
Indoor noise level (Turbo/Hi/Mi/Lo/Si)	dB(A)	48/43/36/34/20	51/45/40/36/20	
Indoor sound power level	dB(A)	58	60	
Indoor unit	Dimension(W*D*H)	mm	975x218x308	1055x231x330
	Packing (W*D*H)	mm	1035x295x385	1130x405x310
	Net/Gross weight	kg	10.3/13.3	12.4/15.9
Outdoor fan motor	Model	ZKFN-34-10-1L-1	ZKFN-80-10-1L	
	Input	W	54.5	99.28
	Output	W	34	80
	Insulation class		B	B
	Waterproofing class		IP24	IP24
	Capacitor	uF	/	/
	Speed	r/min	830/700/650	900/550

Outdoor coil	Number of rows		2.0	1.6
	Tube pitch(a)x row pitch(b)	mm	18x17.3	18x17.3
	Fin spacing	mm	1.3	1.3
	Fin type (code)		Hydrophilic aluminum	Hydrophilic aluminum
	Tube outside dia.and type	mm	Φ5,inner groove tube	Φ5,inner groove tube
	Coil length x height x width	mm	870x504x34.6	900*612*17.3+540*612*17.3
	Number of circuits		8	8
Outdoor air flow		m ³ /h	2100	3500
Outdoor sound pressure level		dB(A)	57.5	60.0
Outdoor sound power level		dB(A)	65.0	68.0
Outdoor unit	Dimension(W*D*H)	mm	805x330x554	890x342x673
	Packing (W*D*H)	mm	915x370x615	995x398x740
	Net/Gross weight	kg	29.8/32.3	38.3/41.5
Refrigerant	Type		R32	R32
	GWP		675	675
	Charged quantity	kg	0.8	0.95
Design pressure		MPa	4.3/1.7	4.3/1.7
Refrigerant piping	Liquid side/ Gas side	mm (inch)	Φ6.35/Φ12.7(1/4"/1/2")	Φ6.35/Φ12.7(1/4"/1/2")
	Max. refrigerant pipe length	m	30	50
	Max. difference in level	m	20	25
Connection wiring			5x1.5	5x2.5
Plug type			3x1.5 / no-plug	3x2.5 / no-plug
Thermostat type			Remote Control	Remote Control
Operation temperature			16-32	16-32
Ambient temperature	Indoor(cooling/ heating)	°C	16~32/0~30	16~32/0~30
	Outdoor(cooling/heating)	°C	-15~50/-25~24	-15~50/-25~24
Qty'per 20' /40' /40'HQ			86/182/208	65/130/150

Notes:

1) Capacities are based on the following conditions:

Cooling(T1): - Indoor Temperature 27°C(80.6°F) DB /19 °C(66.2°F) WB
 -Outdoor Temperature 35 °C(95°F) DB /24 °C(75.2°F) WB
 -Interconnecting Piping Length 5m
 - Level Difference of Zero.

Heating: - Indoor Temperature 20°C(68°F) DB / 15°C(59°F) WB
 -Outdoor Temperature 7°C(44.6°F) DB / 6°C(42.8°F) WB
 - Interconnecting Piping Length 5 m
 - Level Difference of Zero.

2) Capacities are Net Capacities.

3) Due to our policy of innovation some specifications may be changed without notification.

1.2 Electrical Characteristics

Model	Outdoor Unit			Power Supply			IFM		Compressor		OFM		
	Phase	Hz	Voltage	MCA	MOP	MFA	W	FLA	MSC	RLA	Qty	W	FLA
None	1	50	220-240 Min:198 Max:264	5.83	9.78	15	31	0.218	/	3.95	1	25	0.674
MUPR-09-H16				7.08	12.03	15	31	0.218	/	4.95	1	25	0.674
None				7.15	12.10	15	35	0.29	/	4.95	1	25	0.674
None				7.08	12.03	15	31	0.218	/	4.95	1	25	0.674
MUPR-12-H16													
None				9.67	16.57	20	35	0.31	/	6.9	1	34	0.73
MUPR-18-H16													
MUPR-24-H16													

Notes:

MCA: Minimum Circuit Amperes (A)

MOP: Maximum rating over current protective device

MFA: Maximum Fuse Amperes (A)

MSC: Maximum Starting Current

RLA: Rated Load Amperes (A)

IFM: Indoor Fan Motor

OFM: Outdoor Fan Motor

FLA: Full Load Amperes (A)

2. Capacity Tables

2.1 Cooling

		MUPR-09-H16																
INDOOR AIRFLOW (CMH)	OUTDOOR DB(°C)	ID WB (°C)	16.0				18.0				19.0				22.0			
		ID DB (°C)	23.0	25.0	27.0	29.0	23.0	25.0	27.0	29.0	23.0	25.0	27.0	29.0	23.0	25.0	27.0	29.0
510	-15	TC	2.86	2.86	2.86	2.87	3.03	3.03	3.04	3.04	3.21	3.22	3.22	3.22	3.40	3.41	3.41	3.42
		S/T	0.63	0.74	0.84	0.96	0.60	0.70	0.80	0.91	0.56	0.66	0.75	0.86	0.53	0.62	0.71	0.81
		PI	0.44	0.44	0.44	0.44	0.46	0.46	0.46	0.47	0.49	0.49	0.49	0.49	0.52	0.52	0.52	0.52
	-10	TC	2.70	2.70	2.70	2.71	2.86	2.86	2.87	2.87	3.03	3.04	3.04	3.04	3.21	3.22	3.22	3.23
		S/T	0.62	0.73	0.83	0.94	0.59	0.69	0.78	0.89	0.55	0.65	0.74	0.84	0.52	0.61	0.69	0.79
		PI	0.42	0.42	0.42	0.42	0.45	0.45	0.45	0.45	0.47	0.47	0.48	0.48	0.50	0.50	0.50	0.50
	-5	TC	2.64	2.64	2.64	2.65	2.79	2.80	2.80	2.80	2.96	2.97	2.97	2.97	3.14	3.14	3.15	3.15
		S/T	0.61	0.72	0.81	0.93	0.58	0.68	0.77	0.88	0.54	0.64	0.72	0.83	0.51	0.60	0.68	0.78
		PI	0.40	0.40	0.40	0.40	0.43	0.43	0.43	0.43	0.45	0.45	0.45	0.45	0.48	0.48	0.48	0.48
	0	TC	2.62	2.63	2.63	2.63	2.78	2.78	2.79	2.79	2.95	2.95	2.95	2.96	3.12	3.13	3.13	3.14
		S/T	0.60	0.71	0.80	0.91	0.57	0.67	0.76	0.86	0.54	0.63	0.71	0.81	0.50	0.59	0.67	0.77
		PI	0.38	0.38	0.38	0.38	0.40	0.41	0.41	0.41	0.43	0.43	0.43	0.43	0.45	0.46	0.46	0.46
	5	TC	2.47	2.48	2.48	2.48	2.62	2.62	2.63	2.63	2.78	2.78	2.78	2.79	2.95	2.95	2.95	2.96
		S/T	0.61	0.72	0.82	0.93	0.58	0.68	0.77	0.88	0.54	0.64	0.73	0.83	0.51	0.60	0.69	0.78
		PI	0.35	0.35	0.35	0.35	0.37	0.37	0.37	0.37	0.39	0.39	0.39	0.39	0.42	0.42	0.42	0.42
	10	TC	2.32	2.32	2.32	2.33	2.46	2.46	2.46	2.47	2.60	2.61	2.61	2.61	2.76	2.76	2.77	2.77
		S/T	0.62	0.73	0.82	0.94	0.58	0.68	0.78	0.89	0.55	0.65	0.73	0.84	0.52	0.61	0.69	0.79
		PI	0.34	0.34	0.34	0.34	0.36	0.36	0.36	0.36	0.38	0.38	0.38	0.38	0.40	0.40	0.40	0.40
	15	TC	2.29	2.29	2.30	2.30	2.43	2.43	2.43	2.44	2.57	2.58	2.58	2.58	2.73	2.73	2.73	2.74
		S/T	0.60	0.70	0.80	0.91	0.56	0.66	0.75	0.86	0.53	0.62	0.71	0.81	0.50	0.59	0.67	0.76
		PI	0.37	0.37	0.37	0.37	0.39	0.39	0.39	0.39	0.41	0.41	0.41	0.42	0.44	0.44	0.44	0.44
	20	TC	2.26	2.27	2.27	2.27	2.40	2.40	2.40	2.41	2.54	2.55	2.55	2.55	2.70	2.70	2.70	2.71
		S/T	0.58	0.68	0.77	0.88	0.54	0.64	0.72	0.83	0.51	0.60	0.68	0.78	0.48	0.57	0.65	0.74
		PI	0.40	0.40	0.40	0.40	0.43	0.43	0.43	0.43	0.45	0.45	0.45	0.45	0.48	0.48	0.48	0.48
	25	TC	2.24	2.24	2.24	2.24	2.37	2.37	2.38	2.38	2.51	2.51	2.52	2.52	2.66	2.67	2.67	2.67
		S/T	0.55	0.65	0.74	0.84	0.52	0.61	0.70	0.80	0.49	0.58	0.66	0.75	0.47	0.55	0.62	0.71
		PI	0.44	0.44	0.44	0.44	0.46	0.46	0.46	0.46	0.49	0.49	0.49	0.49	0.52	0.52	0.52	0.52
	30	TC	2.26	2.26	2.26	2.27	2.39	2.40	2.40	2.40	2.54	2.54	2.54	2.55	2.69	2.69	2.70	2.70
		S/T	0.58	0.69	0.78	0.89	0.55	0.65	0.74	0.84	0.52	0.61	0.69	0.79	0.49	0.58	0.65	0.75
		PI	0.56	0.56	0.56	0.56	0.59	0.59	0.59	0.59	0.63	0.63	0.63	0.63	0.67	0.67	0.67	0.67
	35	TC	2.31	2.31	2.31	2.32	2.45	2.45	2.45	2.46	2.59	2.60	2.60	2.60	2.75	2.75	2.76	2.76
		S/T	0.64	0.75	0.85	0.97	0.60	0.71	0.81	0.92	0.57	0.67	0.76	0.87	0.54	0.63	0.72	0.82
		PI	0.73	0.73	0.73	0.73	0.77	0.77	0.77	0.77	0.82	0.82	0.82	0.82	0.87	0.87	0.87	0.87
	40	TC	2.00	2.00	2.01	2.01	2.12	2.12	2.13	2.13	2.25	2.25	2.25	2.26	2.38	2.39	2.39	2.39
		S/T	0.69	0.81	0.92	1.00	0.65	0.76	0.87	0.99	0.61	0.72	0.82	0.93	0.58	0.68	0.77	0.88
		PI	0.65	0.65	0.65	0.65	0.69	0.69	0.69	0.69	0.73	0.73	0.73	0.73	0.77	0.77	0.77	0.77
	45	TC	1.55	1.55	1.55	1.55	1.64	1.64	1.64	1.65	1.74	1.74	1.74	1.75	1.84	1.85	1.85	1.85
		S/T	0.73	0.86	0.98	1.00	0.69	0.81	0.92	1.00	0.65	0.77	0.87	0.99	0.62	0.72	0.82	0.94
		PI	0.53	0.53	0.53	0.53	0.56	0.56	0.56	0.57	0.60	0.60	0.60	0.60	0.63	0.63	0.63	0.64
	50	TC	0.88	0.88	0.88	0.88	0.93	0.93	0.93	0.93	0.98	0.98	0.99	0.99	1.04	1.04	1.04	1.05
		S/T	0.75	0.88	1.00	1.00	0.73	0.86	0.98	1.00	0.69	0.81	0.92	1.00	0.65	0.76	0.87	0.99
		PI	0.37	0.37	0.37	0.37	0.39	0.39	0.39	0.39	0.41	0.41	0.41	0.41	0.43	0.44	0.44	0.44

TC:Total Cooling Capacity (kW)

S/T:Sensible Cooling Capacity Ratio

PI:Power Input(kW)

Note: The table shows the case where the operation frequency of a compressor is fixed.

MUPR-12-H16																		
INDOOR AIRFLOW (CMH)	OUTDOOR DB(°C)	ID WB (°C)	16.0				18.0				19.0				22.0			
		ID DB (°C)	23.0	25.0	27.0	29.0	23.0	25.0	27.0	29.0	23.0	25.0	27.0	29.0	23.0	25.0	27.0	29.0
590	-15	TC	3.85	3.85	3.86	3.86	4.08	4.08	4.09	4.09	4.32	4.33	4.33	4.34	4.58	4.59	4.59	4.60
		S/T	0.63	0.74	0.84	0.96	0.60	0.70	0.80	0.91	0.56	0.66	0.75	0.86	0.53	0.62	0.71	0.81
		PI	0.72	0.72	0.72	0.72	0.76	0.76	0.77	0.77	0.81	0.81	0.81	0.81	0.86	0.86	0.86	0.86
	-10	TC	3.63	3.64	3.64	3.65	3.85	3.86	3.86	3.86	4.08	4.09	4.09	4.10	4.33	4.33	4.34	4.34
		S/T	0.62	0.73	0.83	0.94	0.59	0.69	0.78	0.89	0.55	0.65	0.74	0.84	0.52	0.61	0.69	0.79
		PI	0.69	0.70	0.70	0.70	0.74	0.74	0.74	0.74	0.78	0.78	0.78	0.78	0.83	0.83	0.83	0.83
	-5	TC	3.55	3.55	3.56	3.56	3.76	3.77	3.77	3.78	3.99	3.99	4.00	4.00	4.23	4.23	4.24	4.24
		S/T	0.61	0.72	0.81	0.93	0.58	0.68	0.77	0.88	0.54	0.64	0.72	0.83	0.51	0.60	0.68	0.78
		PI	0.66	0.66	0.66	0.67	0.70	0.70	0.70	0.71	0.75	0.75	0.75	0.75	0.79	0.79	0.79	0.79
	0	TC	3.53	3.54	3.54	3.54	3.74	3.75	3.75	3.76	3.97	3.97	3.98	3.98	4.21	4.21	4.22	4.22
		S/T	0.60	0.71	0.80	0.91	0.57	0.67	0.76	0.86	0.54	0.63	0.71	0.81	0.50	0.59	0.67	0.77
		PI	0.63	0.63	0.63	0.63	0.67	0.67	0.67	0.67	0.71	0.71	0.71	0.71	0.75	0.75	0.75	0.75
	5	TC	3.33	3.33	3.34	3.34	3.53	3.53	3.54	3.54	3.74	3.74	3.75	3.75	3.97	3.97	3.97	3.98
		S/T	0.61	0.72	0.82	0.93	0.58	0.68	0.77	0.88	0.54	0.64	0.73	0.83	0.51	0.60	0.69	0.78
		PI	0.58	0.58	0.58	0.58	0.61	0.61	0.61	0.61	0.65	0.65	0.65	0.65	0.69	0.69	0.69	0.69
	10	TC	3.12	3.12	3.13	3.13	3.31	3.31	3.31	3.32	3.51	3.51	3.51	3.52	3.72	3.72	3.72	3.73
		S/T	0.62	0.73	0.82	0.94	0.58	0.68	0.78	0.89	0.55	0.65	0.73	0.84	0.52	0.61	0.69	0.79
		PI	0.55	0.55	0.55	0.55	0.58	0.59	0.59	0.59	0.62	0.62	0.62	0.62	0.66	0.66	0.66	0.66
	15	TC	3.08	3.09	3.09	3.09	3.27	3.27	3.28	3.28	3.46	3.47	3.47	3.48	3.67	3.68	3.68	3.69
		S/T	0.60	0.70	0.80	0.91	0.56	0.66	0.75	0.86	0.53	0.62	0.71	0.81	0.50	0.59	0.67	0.76
		PI	0.61	0.61	0.61	0.61	0.64	0.64	0.64	0.65	0.68	0.68	0.68	0.68	0.72	0.72	0.72	0.73
	20	TC	3.05	3.05	3.05	3.06	3.23	3.23	3.24	3.24	3.42	3.43	3.43	3.44	3.63	3.63	3.64	3.64
		S/T	0.58	0.68	0.77	0.88	0.54	0.64	0.72	0.83	0.51	0.60	0.68	0.78	0.48	0.57	0.65	0.74
		PI	0.66	0.66	0.66	0.66	0.70	0.70	0.70	0.70	0.74	0.74	0.75	0.75	0.79	0.79	0.79	0.79
	25	TC	3.01	3.01	3.02	3.02	3.19	3.19	3.20	3.20	3.38	3.39	3.39	3.39	3.58	3.59	3.59	3.60
		S/T	0.55	0.65	0.74	0.84	0.52	0.61	0.70	0.80	0.49	0.58	0.66	0.75	0.47	0.55	0.62	0.71
		PI	0.72	0.72	0.72	0.72	0.76	0.76	0.76	0.76	0.81	0.81	0.81	0.81	0.85	0.85	0.86	0.86
	30	TC	3.04	3.04	3.05	3.05	3.22	3.23	3.23	3.24	3.42	3.42	3.42	3.43	3.62	3.63	3.63	3.64
		S/T	0.58	0.69	0.78	0.89	0.55	0.65	0.74	0.84	0.52	0.61	0.69	0.79	0.49	0.58	0.65	0.75
		PI	0.92	0.92	0.92	0.92	0.97	0.98	0.98	0.98	1.03	1.03	1.04	1.04	1.10	1.10	1.10	1.10
	35	TC	3.11	3.11	3.11	3.12	3.29	3.30	3.30	3.31	3.49	3.50	3.50	3.50	3.70	3.71	3.71	3.72
		S/T	0.64	0.75	0.85	0.97	0.60	0.71	0.81	0.92	0.57	0.67	0.76	0.87	0.54	0.63	0.72	0.82
		PI	1.20	1.20	1.20	1.20	1.27	1.27	1.27	1.28	1.35	1.35	1.35	1.35	1.43	1.43	1.43	1.43
	40	TC	2.69	2.70	2.70	2.70	2.86	2.86	2.86	2.87	3.03	3.03	3.03	3.04	3.21	3.21	3.22	3.22
		S/T	0.69	0.81	0.92	1.00	0.65	0.76	0.87	0.99	0.61	0.72	0.82	0.93	0.58	0.68	0.77	0.88
		PI	1.06	1.07	1.07	1.07	1.13	1.13	1.13	1.13	1.20	1.20	1.20	1.20	1.27	1.27	1.27	1.27
	45	TC	2.08	2.09	2.09	2.09	2.21	2.21	2.21	2.22	2.34	2.34	2.35	2.35	2.48	2.49	2.49	2.49
		S/T	0.73	0.86	0.98	1.00	0.69	0.81	0.92	1.00	0.65	0.77	0.87	0.99	0.62	0.72	0.82	0.94
		PI	0.87	0.88	0.88	0.88	0.93	0.93	0.93	0.93	0.98	0.98	0.99	0.99	1.04	1.04	1.04	1.05
	50	TC	1.18	1.18	1.18	1.18	1.25	1.25	1.25	1.25	1.32	1.33	1.33	1.33	1.40	1.40	1.41	1.41
		S/T	0.75	0.88	1.00	1.00	0.73	0.86	0.98	1.00	0.69	0.81	0.92	1.00	0.65	0.76	0.87	0.99
		PI	0.60	0.60	0.60	0.60	0.64	0.64	0.64	0.64	0.68	0.68	0.68	0.68	0.72	0.72	0.72	0.72

TC:Total Cooling Capacity (kW)

S/T:Sensible Cooling Capacity Ratio

PI:Power Input(kW)

Note: The table shows the case where the operation frequency of a compressor is fixed.

MUPR-18-H16																		
INDOOR AIRFLOW (CMH)	OUTDOOR DB(°C)	ID WB (°C)	16.0				18.0				19.0				22.0			
		ID DB (°C)	23.0	25.0	27.0	29.0	23.0	25.0	27.0	29.0	23.0	25.0	27.0	29.0	23.0	25.0	27.0	29.0
800	-15	TC	5.72	5.72	5.73	5.74	6.06	6.07	6.07	6.08	6.42	6.43	6.44	6.45	6.81	6.82	6.82	6.83
		S/T	0.63	0.74	0.84	0.96	0.60	0.70	0.80	0.91	0.56	0.66	0.75	0.86	0.53	0.62	0.71	0.81
		PI	0.85	0.85	0.86	0.86	0.91	0.91	0.91	0.91	0.96	0.96	0.96	0.96	1.02	1.02	1.02	1.02
	-10	TC	5.40	5.40	5.41	5.42	5.72	5.73	5.73	5.74	6.06	6.07	6.08	6.09	6.43	6.43	6.44	6.45
		S/T	0.62	0.73	0.83	0.94	0.59	0.69	0.78	0.89	0.55	0.65	0.74	0.84	0.52	0.61	0.69	0.79
		PI	0.82	0.82	0.83	0.83	0.87	0.87	0.87	0.88	0.93	0.93	0.93	0.93	0.98	0.98	0.98	0.98
	-5	TC	5.27	5.28	5.28	5.29	5.59	5.60	5.60	5.61	5.92	5.93	5.94	5.95	6.28	6.29	6.29	6.30
		S/T	0.61	0.72	0.81	0.93	0.58	0.68	0.77	0.88	0.54	0.64	0.72	0.83	0.51	0.60	0.68	0.78
		PI	0.79	0.79	0.79	0.79	0.83	0.83	0.84	0.84	0.88	0.88	0.89	0.89	0.94	0.94	0.94	0.94
	0	TC	5.25	5.25	5.26	5.27	5.56	5.57	5.57	5.58	5.89	5.90	5.91	5.92	6.25	6.26	6.26	6.27
		S/T	0.60	0.71	0.80	0.91	0.57	0.67	0.76	0.86	0.54	0.63	0.71	0.81	0.50	0.59	0.67	0.77
		PI	0.74	0.75	0.75	0.75	0.79	0.79	0.79	0.79	0.84	0.84	0.84	0.84	0.89	0.89	0.89	0.89
	5	TC	4.94	4.95	4.96	4.96	5.24	5.25	5.25	5.26	5.56	5.56	5.57	5.58	5.89	5.90	5.90	5.91
		S/T	0.61	0.72	0.82	0.93	0.58	0.68	0.77	0.88	0.54	0.64	0.73	0.83	0.51	0.60	0.69	0.78
		PI	0.68	0.68	0.68	0.68	0.72	0.72	0.72	0.73	0.77	0.77	0.77	0.77	0.81	0.81	0.81	0.81
	10	TC	4.63	4.64	4.65	4.65	4.91	4.92	4.92	4.93	5.21	5.21	5.22	5.23	5.52	5.53	5.53	5.54
		S/T	0.62	0.73	0.82	0.94	0.58	0.68	0.78	0.89	0.55	0.65	0.73	0.84	0.52	0.61	0.69	0.79
		PI	0.65	0.65	0.66	0.66	0.69	0.69	0.69	0.70	0.73	0.74	0.74	0.74	0.78	0.78	0.78	0.78
	15	TC	4.58	4.59	4.59	4.60	4.86	4.86	4.87	4.87	5.15	5.15	5.16	5.17	5.46	5.46	5.47	5.48
		S/T	0.60	0.70	0.80	0.91	0.56	0.66	0.75	0.86	0.53	0.62	0.71	0.81	0.50	0.59	0.67	0.76
		PI	0.72	0.72	0.72	0.72	0.76	0.76	0.76	0.76	0.81	0.81	0.81	0.81	0.86	0.86	0.86	0.86
	20	TC	4.53	4.53	4.54	4.54	4.80	4.80	4.81	4.82	5.08	5.09	5.10	5.10	5.39	5.40	5.40	5.41
		S/T	0.58	0.68	0.77	0.88	0.54	0.64	0.72	0.83	0.51	0.60	0.68	0.78	0.48	0.57	0.65	0.74
		PI	0.78	0.79	0.79	0.79	0.83	0.83	0.83	0.83	0.88	0.88	0.88	0.88	0.93	0.94	0.94	0.94
	25	TC	4.47	4.48	4.48	4.49	4.74	4.75	4.75	4.76	5.02	5.03	5.04	5.04	5.33	5.33	5.34	5.34
		S/T	0.55	0.65	0.74	0.84	0.52	0.61	0.70	0.80	0.49	0.58	0.66	0.75	0.47	0.55	0.62	0.71
		PI	0.85	0.85	0.85	0.85	0.90	0.90	0.90	0.90	0.95	0.96	0.96	0.96	1.01	1.01	1.01	1.02
	30	TC	4.52	4.52	4.53	4.53	4.79	4.80	4.80	4.81	5.08	5.08	5.09	5.09	5.38	5.39	5.39	5.40
		S/T	0.58	0.69	0.78	0.89	0.55	0.65	0.74	0.84	0.52	0.61	0.69	0.79	0.49	0.58	0.65	0.75
		PI	1.09	1.09	1.09	1.09	1.16	1.16	1.16	1.16	1.22	1.23	1.23	1.23	1.30	1.30	1.30	1.30
	35	TC	4.62	4.62	4.63	4.63	4.89	4.90	4.91	4.91	5.19	5.19	5.20	5.21	5.50	5.51	5.51	5.52
		S/T	0.64	0.75	0.85	0.97	0.60	0.71	0.81	0.92	0.57	0.67	0.76	0.87	0.54	0.63	0.72	0.82
		PI	1.42	1.42	1.42	1.43	1.51	1.51	1.51	1.51	1.60	1.60	1.60	1.60	1.69	1.69	1.70	1.70
	40	TC	4.00	4.01	4.01	4.02	4.24	4.25	4.25	4.26	4.50	4.50	4.51	4.51	4.77	4.77	4.78	4.79
		S/T	0.69	0.81	0.92	1.00	0.65	0.76	0.87	0.99	0.61	0.72	0.82	0.93	0.58	0.68	0.77	0.88
		PI	1.26	1.26	1.27	1.27	1.34	1.34	1.34	1.34	1.42	1.42	1.42	1.42	1.50	1.51	1.51	1.51
	45	TC	3.10	3.10	3.10	3.11	3.28	3.29	3.29	3.29	3.48	3.48	3.49	3.49	3.69	3.69	3.70	3.70
		S/T	0.73	0.86	0.98	1.00	0.69	0.81	0.92	1.00	0.65	0.77	0.87	0.99	0.62	0.72	0.82	0.94
		PI	1.04	1.04	1.04	1.04	1.10	1.10	1.10	1.10	1.17	1.17	1.17	1.17	1.24	1.24	1.24	1.24
	50	TC	1.75	1.75	1.75	1.76	1.86	1.86	1.86	1.86	1.97	1.97	1.97	1.97	2.09	2.09	2.09	2.09
		S/T	0.75	0.88	1.00	1.00	0.73	0.86	0.98	1.00	0.69	0.81	0.92	1.00	0.65	0.76	0.87	0.99
		PI	0.71	0.71	0.71	0.72	0.76	0.76	0.76	0.76	0.80	0.80	0.80	0.80	0.85	0.85	0.85	0.85

TC:Total Cooling Capacity (kW)

S/T:Sensible Cooling Capacity Ratio

PI:Power Input(kW)

Note: The table shows the case where the operation frequency of a compressor is fixed.

MUPR-24-H16																		
INDOOR AIRFLOW (CMH)	OUTDOOR DB(°C)	ID WB (°C)	16.0				18.0				19.0				22.0			
		ID DB (°C)	23.0	25.0	27.0	29.0	23.0	25.0	27.0	29.0	23.0	25.0	27.0	29.0	23.0	25.0	27.0	29.0
1050	-15	TC	7.69	7.70	7.71	7.72	8.16	8.17	8.18	8.19	8.65	8.66	8.67	8.68	9.17	9.18	9.19	9.20
		S/T	0.63	0.74	0.84	0.96	0.60	0.70	0.80	0.91	0.56	0.66	0.75	0.86	0.53	0.62	0.71	0.81
		PI	1.39	1.39	1.39	1.39	1.47	1.47	1.47	1.48	1.56	1.56	1.56	1.56	1.65	1.65	1.66	1.66
	-10	TC	7.26	7.27	7.28	7.29	7.70	7.71	7.72	7.73	8.16	8.17	8.18	8.19	8.65	8.66	8.67	8.68
		S/T	0.62	0.73	0.83	0.94	0.59	0.69	0.78	0.89	0.55	0.65	0.74	0.84	0.52	0.61	0.69	0.79
		PI	1.34	1.34	1.34	1.34	1.42	1.42	1.42	1.42	1.50	1.51	1.51	1.51	1.59	1.60	1.60	1.60
	-5	TC	7.10	7.11	7.11	7.12	7.52	7.53	7.54	7.55	7.97	7.98	7.99	8.00	8.45	8.46	8.47	8.48
		S/T	0.61	0.72	0.81	0.93	0.58	0.68	0.77	0.88	0.54	0.64	0.72	0.83	0.51	0.60	0.68	0.78
		PI	1.28	1.28	1.28	1.28	1.35	1.36	1.36	1.36	1.43	1.44	1.44	1.44	1.52	1.52	1.52	1.53
	0	TC	7.06	7.07	7.08	7.09	7.49	7.50	7.50	7.51	7.93	7.94	7.95	7.96	8.41	8.42	8.43	8.44
		S/T	0.60	0.71	0.80	0.91	0.57	0.67	0.76	0.86	0.54	0.63	0.71	0.81	0.50	0.59	0.67	0.77
		PI	1.21	1.21	1.21	1.22	1.28	1.28	1.29	1.29	1.36	1.36	1.36	1.37	1.44	1.44	1.45	1.45
	5	TC	6.66	6.67	6.67	6.68	7.06	7.07	7.07	7.08	7.48	7.49	7.50	7.51	7.93	7.94	7.95	7.96
		S/T	0.61	0.72	0.82	0.93	0.58	0.68	0.77	0.88	0.54	0.64	0.73	0.83	0.51	0.60	0.69	0.78
		PI	1.11	1.11	1.11	1.11	1.17	1.18	1.18	1.18	1.24	1.25	1.25	1.25	1.32	1.32	1.32	1.32
	10	TC	6.24	6.25	6.25	6.26	6.62	6.62	6.63	6.64	7.01	7.02	7.03	7.04	7.43	7.44	7.45	7.46
		S/T	0.62	0.73	0.82	0.94	0.58	0.68	0.78	0.89	0.55	0.65	0.73	0.84	0.52	0.61	0.69	0.79
		PI	1.06	1.06	1.06	1.07	1.13	1.13	1.13	1.13	1.19	1.20	1.20	1.20	1.27	1.27	1.27	1.27
	15	TC	6.17	6.17	6.18	6.19	6.54	6.54	6.55	6.56	6.93	6.94	6.94	6.95	7.35	7.35	7.36	7.37
		S/T	0.60	0.70	0.80	0.91	0.56	0.66	0.75	0.86	0.53	0.62	0.71	0.81	0.50	0.59	0.67	0.76
		PI	1.17	1.17	1.17	1.17	1.24	1.24	1.24	1.24	1.31	1.31	1.32	1.32	1.39	1.39	1.39	1.40
	20	TC	6.09	6.10	6.11	6.12	6.46	6.47	6.47	6.48	6.84	6.85	6.86	6.87	7.26	7.27	7.27	7.28
		S/T	0.58	0.68	0.77	0.88	0.54	0.64	0.72	0.83	0.51	0.60	0.68	0.78	0.48	0.57	0.65	0.74
		PI	1.27	1.28	1.28	1.28	1.35	1.35	1.35	1.36	1.43	1.43	1.44	1.44	1.52	1.52	1.52	1.52
	25	TC	6.02	6.03	6.03	6.04	6.38	6.39	6.39	6.40	6.76	6.77	6.78	6.79	7.17	7.18	7.19	7.20
		S/T	0.55	0.65	0.74	0.84	0.52	0.61	0.70	0.80	0.49	0.58	0.66	0.75	0.47	0.55	0.62	0.71
		PI	1.38	1.38	1.38	1.39	1.46	1.47	1.47	1.47	1.55	1.55	1.55	1.56	1.64	1.65	1.65	1.65
	30	TC	6.08	6.09	6.10	6.10	6.45	6.46	6.46	6.47	6.83	6.84	6.85	6.86	7.24	7.25	7.26	7.27
		S/T	0.58	0.69	0.78	0.89	0.55	0.65	0.74	0.84	0.52	0.61	0.69	0.79	0.49	0.58	0.65	0.75
		PI	1.77	1.77	1.78	1.78	1.88	1.88	1.88	1.88	1.99	1.99	1.99	2.00	2.11	2.11	2.11	2.12
	35	TC	6.21	6.22	6.23	6.24	6.59	6.60	6.60	6.61	6.98	6.99	7.00	7.01	7.40	7.41	7.42	7.43
		S/T	0.64	0.75	0.85	0.97	0.60	0.71	0.81	0.92	0.57	0.67	0.76	0.87	0.54	0.63	0.72	0.82
		PI	2.31	2.31	2.31	2.32	2.45	2.45	2.45	2.46	2.59	2.60	2.60	2.60	2.75	2.75	2.76	2.76
	40	TC	5.39	5.40	5.40	5.41	5.71	5.72	5.73	5.73	6.05	6.06	6.07	6.08	6.42	6.43	6.43	6.44
		S/T	0.69	0.81	0.92	1.00	0.65	0.76	0.87	0.99	0.61	0.72	0.82	0.93	0.58	0.68	0.77	0.88
		PI	2.05	2.05	2.06	2.06	2.17	2.18	2.18	2.18	2.30	2.31	2.31	2.31	2.44	2.45	2.45	2.45
	45	TC	4.17	4.17	4.18	4.18	4.42	4.42	4.43	4.43	4.68	4.69	4.69	4.70	4.97	4.97	4.98	4.98
		S/T	0.73	0.86	0.98	1.00	0.69	0.81	0.92	1.00	0.65	0.77	0.87	0.99	0.62	0.72	0.82	0.94
		PI	1.69	1.69	1.69	1.69	1.79	1.79	1.79	1.79	1.89	1.90	1.90	1.90	2.01	2.01	2.01	2.01
	50	TC	2.36	2.36	2.36	2.37	2.50	2.50	2.50	2.51	2.65	2.65	2.65	2.66	2.81	2.81	2.81	2.82
		S/T	0.75	0.88	1.00	1.00	0.73	0.86	0.98	1.00	0.69	0.81	0.92	1.00	0.65	0.76	0.87	0.99
		PI	1.16	1.16	1.16	1.16	1.23	1.23	1.23	1.23	1.30	1.30	1.30	1.31	1.38	1.38	1.38	1.38

TC:Total Cooling Capacity (kW)

S/T:Sensible Cooling Capacity Ratio

PI:Power Input(kW)

Note: The table shows the case where the operation frequency of a compressor is fixed.

2.2 Heating

MUPR-09-H16									[SI_Unit]
INDOOR AIRFLOW (CMH)	HEATING PERFORMANCE AT INDOOR DRY BULB TEMPERATURE								
	OUTDOOR DB(°C)	TC:TOTAL CAPACITY IN KILOWATTS (KW)				PI:TOTAL POWER IN KILOWATTS (KW)			
		Indoor Conditions (DB °C)				Indoor Conditions (DB °C)			
		16.0	20.0	22.0	24.0	16.0	20.0	22.0	24.0
510	-20.0	1.62	1.60	1.57	1.57	0.43	0.44	0.46	0.47
	-15.0	1.75	1.73	1.70	1.70	0.47	0.48	0.51	0.52
	-10.0	1.87	1.85	1.82	1.82	0.50	0.51	0.54	0.55
	-7.0	1.96	1.93	1.91	1.91	0.54	0.55	0.57	0.58
	-5.6	2.08	2.05	2.02	2.02	0.55	0.57	0.58	0.60
	-2.8	2.19	2.16	2.14	2.14	0.58	0.61	0.62	0.64
	0.0	2.25	2.22	2.22	2.19	0.61	0.64	0.66	0.68
	2.8	2.42	2.40	2.37	2.37	0.66	0.69	0.71	0.72
	5.6	2.68	2.66	2.63	2.60	0.70	0.73	0.75	0.77
	7.0	2.96	2.93	2.84	2.81	0.72	0.79	0.78	0.80
	11.1	3.13	3.10	3.08	3.08	0.78	0.82	0.84	0.86
	13.9	3.31	3.28	3.25	3.22	0.82	0.86	0.88	0.90
	16.7	3.48	3.42	3.42	3.39	0.86	0.90	0.92	0.95
18.0	3.57	3.51	3.48	3.48	0.88	0.92	0.94	0.97	

Note: The table shows the case where the operation frequency of a compressor is fixed.

None+MUPR-09-H16-E									[SI_Unit]
INDOOR AIRFLOW (CMH)	HEATING PERFORMANCE AT INDOOR DRY BULB TEMPERATURE								
	OUTDOOR DB(°C)	TC:TOTAL CAPACITY IN KILOWATTS (KW)				PI:TOTAL POWER IN KILOWATTS (KW)			
		Indoor Conditions (DB °C)				Indoor Conditions (DB °C)			
		16.0	20.0	22.0	24.0	16.0	20.0	22.0	24.0
510	-20.0	1.62	1.60	1.57	1.57	0.40	0.41	0.42	0.44
	-15.0	1.75	1.73	1.70	1.70	0.44	0.44	0.46	0.48
	-10.0	1.87	1.85	1.82	1.82	0.46	0.47	0.49	0.51
	-7.0	1.96	1.93	1.91	1.91	0.49	0.50	0.52	0.54
	-5.6	2.08	2.05	2.02	2.02	0.50	0.53	0.54	0.55
	-2.8	2.19	2.16	2.14	2.14	0.54	0.56	0.58	0.59
	0.0	2.25	2.22	2.22	2.19	0.57	0.60	0.61	0.62
	2.8	2.42	2.40	2.37	2.37	0.61	0.64	0.65	0.67
	5.6	2.68	2.66	2.63	2.60	0.65	0.68	0.70	0.71
	7.0	2.96	2.93	2.84	2.81	0.67	0.73	0.72	0.74
	11.1	3.13	3.10	3.08	3.08	0.72	0.76	0.78	0.79
	13.9	3.31	3.28	3.25	3.22	0.76	0.80	0.81	0.83
	16.7	3.48	3.42	3.42	3.39	0.80	0.83	0.85	0.87
18.0	3.57	3.51	3.48	3.48	0.81	0.85	0.87	0.89	

Note: The table shows the case where the operation frequency of a compressor is fixed.

MUPR-12-H16									[SL_Unit]
INDOOR AIRFLOW (CMH)	HEATING PERFORMANCE AT INDOOR DRY BULB TEMPERATURE								
	OUTDOOR DB(°C)	TC:TOTAL CAPACITY IN KILOWATTS (KW)				PI:TOTAL POWER IN KILOWATTS (KW)			
		Indoor Conditions (DB °C)				Indoor Conditions (DB °C)			
		16.0	20.0	22.0	24.0	16.0	20.0	22.0	24.0
590	-20.0	2.10	2.08	2.05	2.05	0.65	0.66	0.69	0.71
	-15.0	2.27	2.25	2.22	2.22	0.71	0.72	0.76	0.78
	-10.0	2.43	2.40	2.37	2.37	0.75	0.77	0.81	0.83
	-7.0	2.54	2.51	2.49	2.49	0.80	0.82	0.86	0.88
	-5.6	2.69	2.66	2.63	2.63	0.82	0.86	0.88	0.90
	-2.8	2.83	2.80	2.77	2.77	0.88	0.92	0.94	0.96
	0.0	2.95	2.89	2.89	2.86	0.93	0.97	1.00	1.02
	2.8	3.15	3.12	3.09	3.06	0.99	1.04	1.07	1.09
	5.6	3.47	3.44	3.41	3.38	1.06	1.11	1.13	1.16
	7.0	3.84	3.81	3.69	3.66	1.09	1.19	1.17	1.20
	11.1	4.10	4.04	4.01	3.98	1.18	1.24	1.26	1.29
	13.9	4.30	4.25	4.22	4.19	1.24	1.30	1.33	1.36
	16.7	4.54	4.48	4.45	4.39	1.30	1.36	1.39	1.42
18.0	4.62	4.57	4.54	4.51	1.32	1.39	1.42	1.45	

Note: The table shows the case where the operation frequency of a compressor is fixed.

MUPR-18-H16									[SL_Unit]
INDOOR AIRFLOW (CMH)	HEATING PERFORMANCE AT INDOOR DRY BULB TEMPERATURE								
	OUTDOOR DB(°C)	TC:TOTAL CAPACITY IN KILOWATTS (KW)				PI:TOTAL POWER IN KILOWATTS (KW)			
		Indoor Conditions (DB °C)				Indoor Conditions (DB °C)			
		16.0	20.0	22.0	24.0	16.0	20.0	22.0	24.0
800	-25.0	2.75	2.71	2.69	2.69	0.69	0.70	0.73	0.76
	-20.0	2.99	2.94	2.92	2.92	0.76	0.77	0.81	0.83
	-15.0	3.24	3.19	3.16	3.16	0.83	0.85	0.88	0.91
	-10.0	3.45	3.40	3.38	3.38	0.88	0.90	0.94	0.97
	-7.0	3.62	3.56	3.54	3.54	0.94	0.96	1.00	1.03
	-5.6	3.82	3.77	3.74	3.74	0.96	1.01	1.04	1.06
	-2.8	4.03	3.97	3.94	3.91	1.03	1.08	1.10	1.13
	0.0	4.17	4.11	4.09	4.06	1.09	1.14	1.17	1.19
	2.8	4.49	4.43	4.40	4.35	1.16	1.22	1.25	1.27
	5.6	4.95	4.90	4.87	4.81	1.24	1.29	1.32	1.34
	7.0	5.46	5.40	5.23	5.20	1.28	1.39	1.37	1.40
	11.1	5.81	5.72	5.69	5.66	1.38	1.44	1.48	1.51
	13.9	6.13	6.04	5.98	5.95	1.44	1.51	1.55	1.58
16.7	6.42	6.33	6.30	6.24	1.51	1.58	1.62	1.66	
18.0	6.56	6.47	6.45	6.39	1.55	1.62	1.66	1.69	

Note: The table shows the case where the operation frequency of a compressor is fixed.

MUPR-24-H16								[SI_Unit]	
INDOOR AIRFLOW (CMH)	HEATING PERFORMANCE AT INDOOR DRY BULB TEMPERATURE								
	OUTDOOR DB(°C)	TC:TOTAL CAPACITY IN KILOWATTS (KW)				PI:TOTAL POWER IN KILOWATTS (KW)			
		Indoor Conditions (DB °C)				Indoor Conditions (DB °C)			
		16.0	20.0	22.0	24.0	16.0	20.0	22.0	24.0
1039	-25.0	3.72	3.68	3.66	3.64	1.06	1.09	1.14	1.16
	-20.0	4.04	4.00	3.97	3.95	1.16	1.20	1.25	1.28
	-15.0	4.37	4.32	4.30	4.28	1.27	1.31	1.37	1.40
	-10.0	4.67	4.62	4.59	4.57	1.36	1.40	1.46	1.49
	-7.0	4.89	4.84	4.81	4.78	1.44	1.48	1.55	1.58
	-5.6	5.19	5.13	5.10	5.07	1.49	1.56	1.60	1.63
	-2.8	5.48	5.39	5.36	5.33	1.58	1.66	1.70	1.74
	0.0	5.68	5.59	5.56	5.50	1.68	1.76	1.80	1.84
	2.8	6.08	6.00	5.97	5.94	1.79	1.88	1.92	1.97
	5.6	6.75	6.63	6.60	6.55	1.91	2.00	2.05	2.09
	7.0	7.46	7.33	7.10	7.07	1.97	2.15	2.12	2.17
	11.1	7.88	7.76	7.74	7.68	2.13	2.23	2.28	2.34
	13.9	8.32	8.20	8.14	8.08	2.24	2.34	2.40	2.45
16.7	8.72	8.60	8.55	8.49	2.34	2.45	2.51	2.57	
18.0	8.92	8.81	8.75	8.69	2.39	2.51	2.56	2.62	

Note: The table shows the case where the operation frequency of a compressor is fixed.

3. Capacity Correction Factor for Height Difference

Capacity(Btu/h)	9k		Pipe Length (m)			
Indoor Upper than Outdoor			5	10	20	25
Height difference H (m)	Cooling	10		0.969	0.936	0.920
		5	0.995	0.979	0.946	0.929
		0	1.000	0.984	0.951	0.934
	Heating	10		0.989	0.967	0.956
		5	1.000	0.989	0.967	0.956
		0	1.000	0.989	0.967	0.956
Outdoor Upper than Indoor			5	10	20	30
Height difference H (m)	Cooling	0	1.000	0.984	0.951	0.934
		5	1.000	0.984	0.951	0.934
		10		0.984	0.951	0.934
	Heating	0	1.000	0.989	0.967	0.956
		5	0.992	0.981	0.959	0.948
		10		0.973	0.952	0.941

Capacity(Btu/h)	12k		Pipe Length (m)			
Indoor Upper than Outdoor			5	10	20	25
Height difference H (m)	Cooling	10		0.973	0.948	0.936
		5	0.995	0.983	0.958	0.945
		0	1.000	0.988	0.963	0.950
	Heating	10		0.993	0.978	0.970
		5	1.000	0.993	0.978	0.970
		0	1.000	0.993	0.978	0.970
Outdoor Upper than Indoor			5	10	20	30
Height difference H (m)	Cooling	0	1.000	0.988	0.963	0.950
		5	1.000	0.988	0.963	0.950
		10		0.988	0.963	0.950
	Heating	0	1.000	0.993	0.978	0.970
		5	0.992	0.985	0.970	0.962
		10		0.977	0.962	0.955

Capacity(Btu/h)	18k	Pipe Length (m)				
Indoor Upper than Outdoor		5	10	20	30	
Height difference H (m)	Cooling	20		0.928	0.912	
		10		0.937	0.921	
		5	0.995	0.979	0.946	0.930
		0	1.000	0.984	0.951	0.935
	Heating	20			0.982	0.976
		10		0.994	0.982	0.976
		5	1.000	0.994	0.982	0.976
		0	1.000	0.994	0.982	0.976
Outdoor Upper than Indoor		5	10	20	30	
Height difference H (m)	Cooling	0	1.000	0.984	0.951	0.935
		5	1.000	0.984	0.951	0.935
		10		0.984	0.951	0.935
		20			0.951	0.935
	Heating	0	1.000	0.994	0.982	0.976
		5	0.992	0.986	0.974	0.968
		10		0.978	0.966	0.960
		20			0.959	0.953

Capacity(Btu/h)	24k		Pipe Length (m)					
Indoor Upper than Outdoor			5	10	20	30	40	50
Height difference H (m)	Cooling	25				0.914	0.894	0.874
		20			0.944	0.924	0.903	0.883
		10		0.975	0.954	0.933	0.912	0.891
		5	0.995	0.984	0.963	0.942	0.921	0.900
		0	1.000	0.989	0.968	0.947	0.926	0.905
	Heating	25				0.983	0.977	0.97
		20			0.990	0.983	0.977	0.97
		10		0.997	0.990	0.983	0.977	0.97
		5	1.000	0.997	0.990	0.983	0.977	0.97
		0	1.000	0.997	0.990	0.983	0.977	0.97
Outdoor Upper than Indoor			5	10	20	30	40	50
Height difference H (m)	Cooling	0	1.000	0.989	0.968	0.947	0.926	0.905
		5	1.000	0.989	0.968	0.947	0.926	0.905
		10		0.989	0.968	0.947	0.926	0.905
		20			0.968	0.947	0.926	0.905
		25				0.947	0.926	0.905
	Heating	0	1.000	0.997	0.990	0.983	0.977	0.970
		5	0.992	0.989	0.982	0.975	0.969	0.962
		10		0.981	0.974	0.968	0.961	0.955
		20			0.966	0.960	0.953	0.947
		25				0.952	0.946	0.939

4. Dimensional Drawings & Centre of gravity

4.1 Dimensional Drawings

4.1.1 Indoor Unit

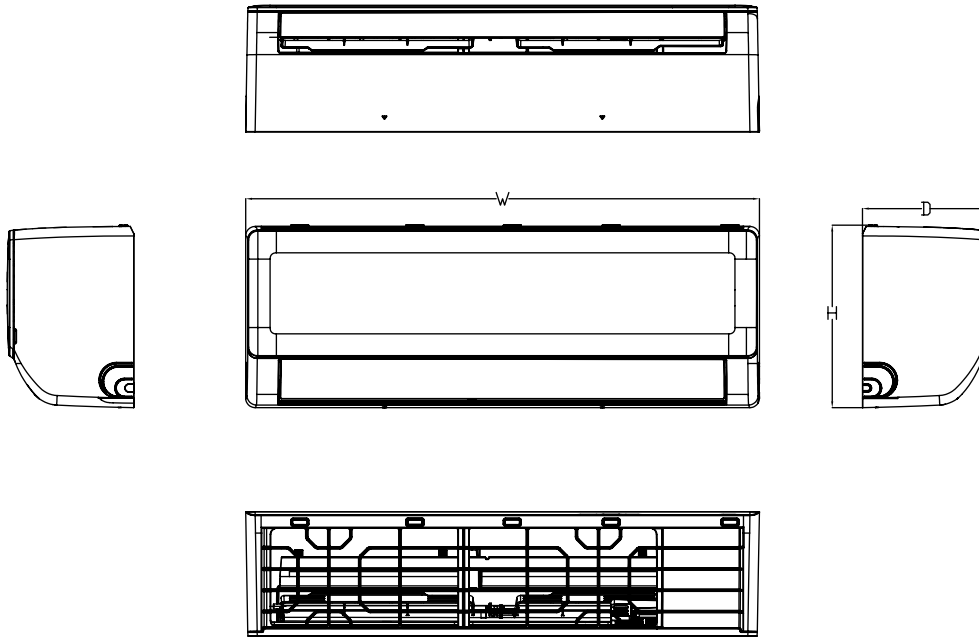

Capacity (Btu/h)	Unit	W	D	H
9k	mm	723	199	286
12k	mm	813	201	289
18k	mm	975	218	308
24k	mm	1055	231	330

4.1.2 Outdoor Unit

9k/12k

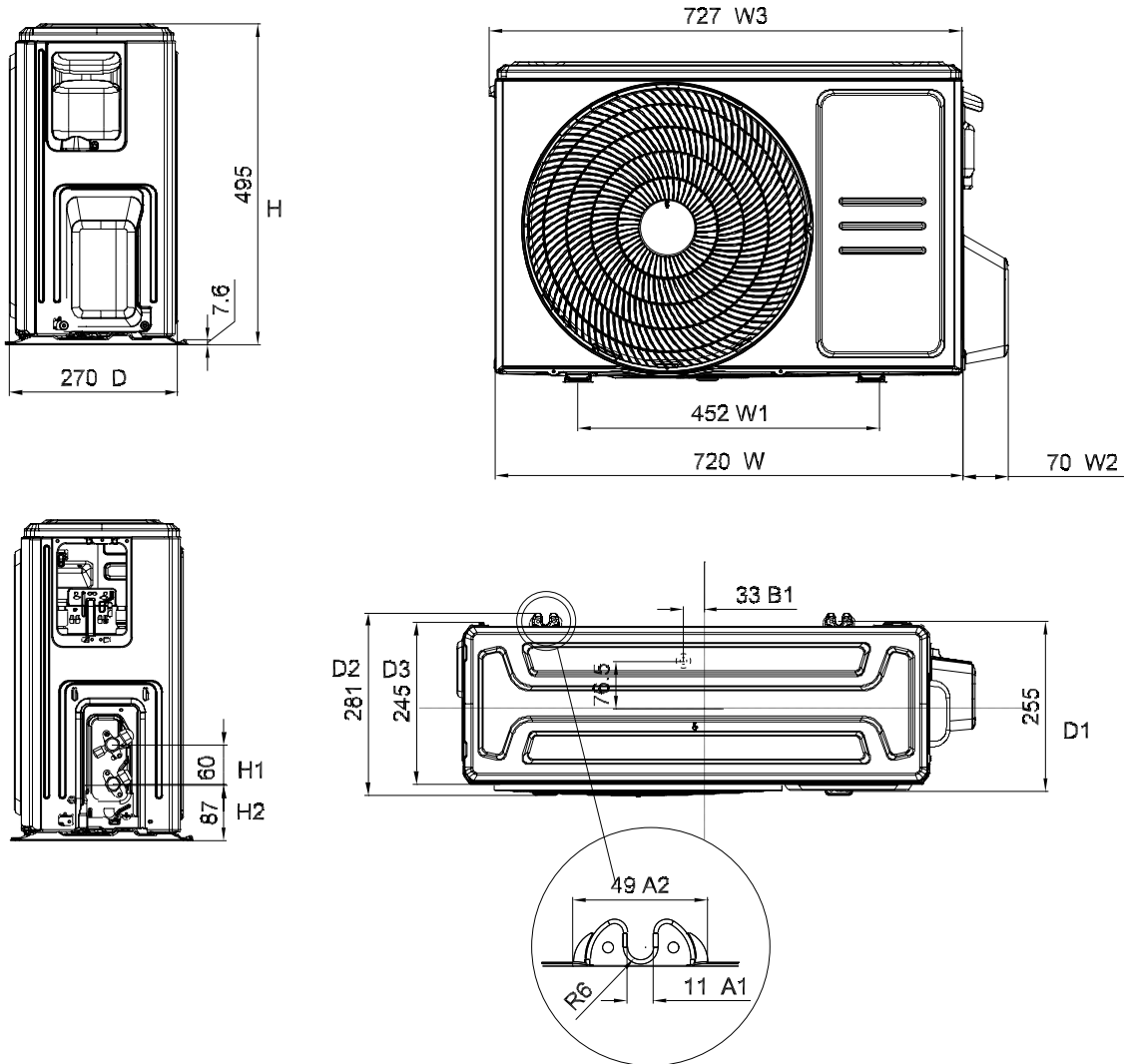

18k

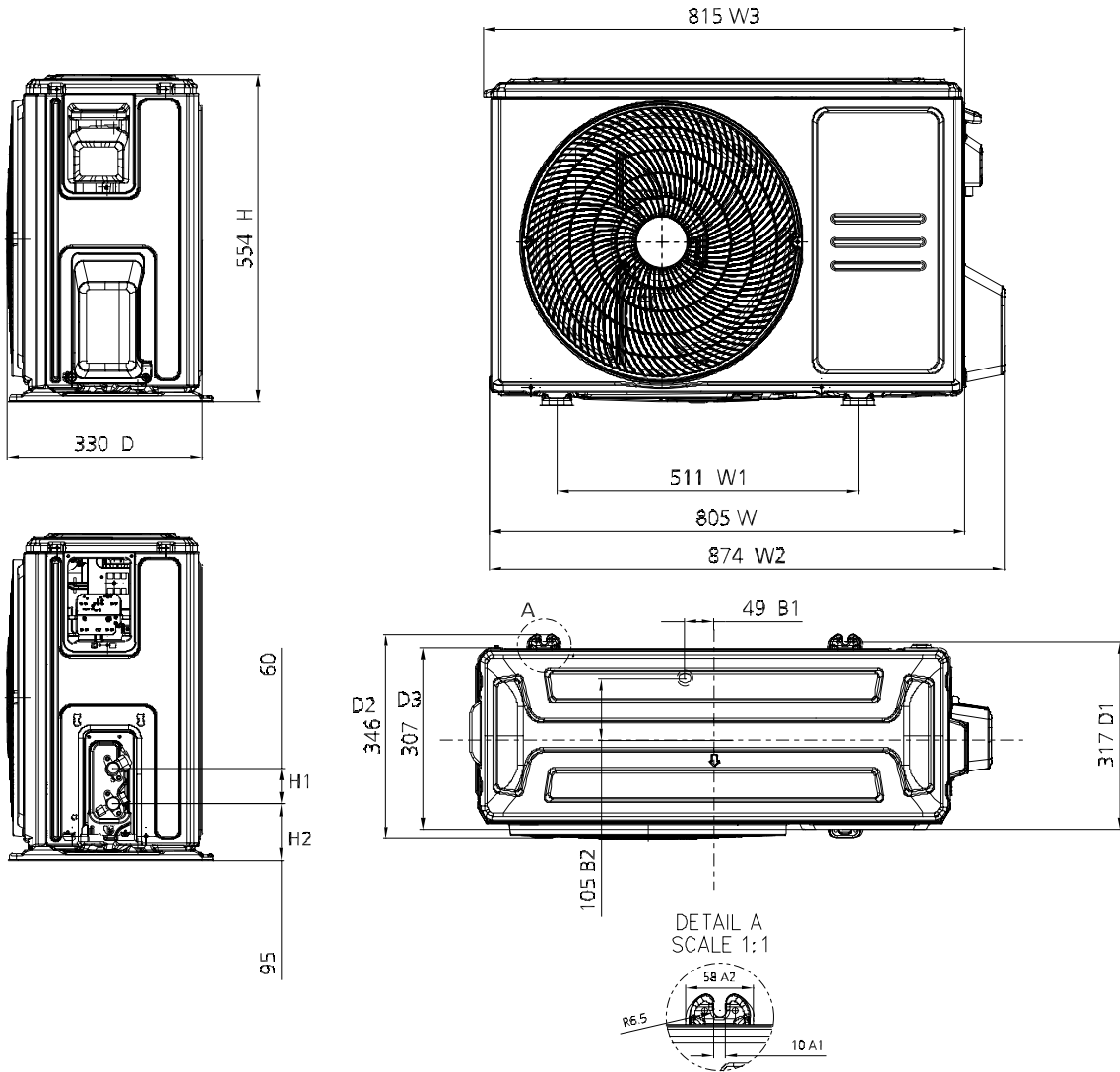

24k

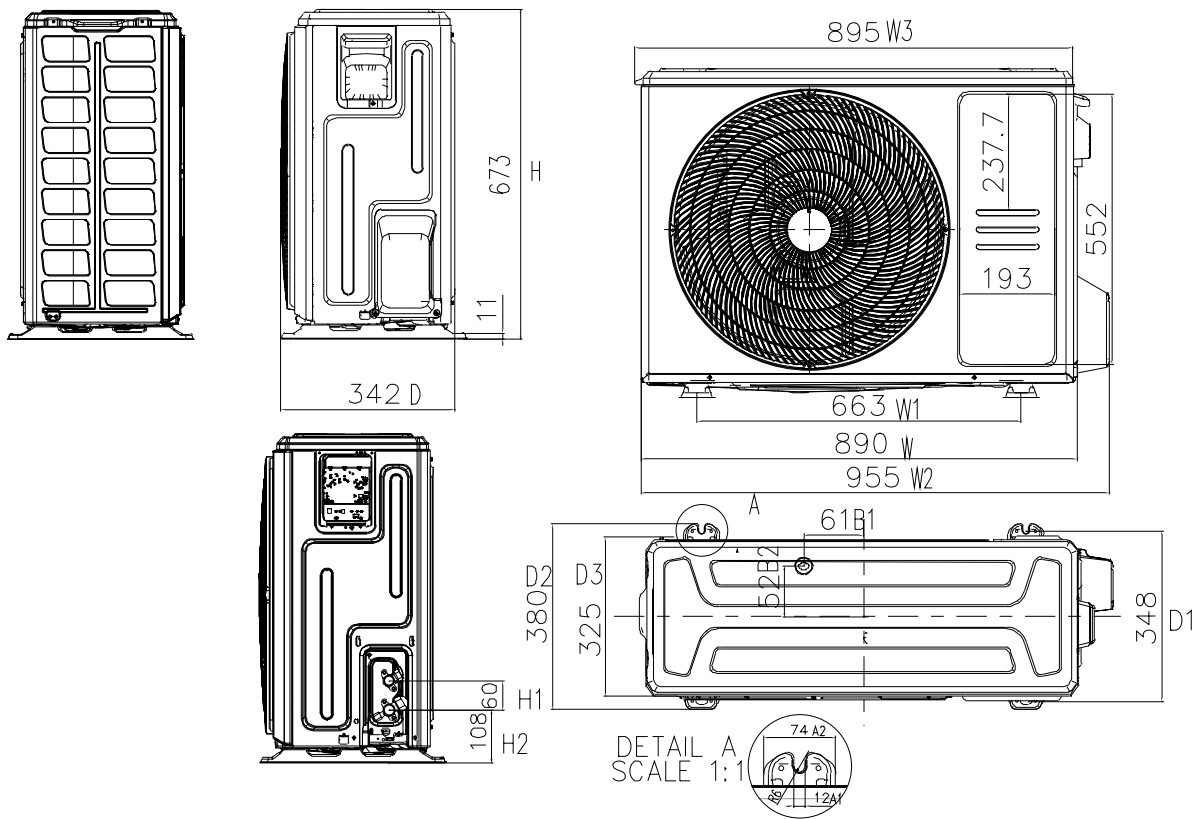

4.2 Centre of gravity

9k/12k

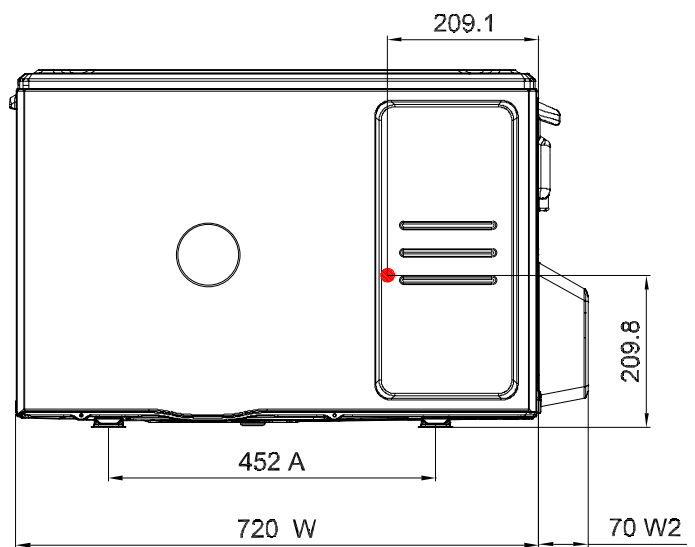
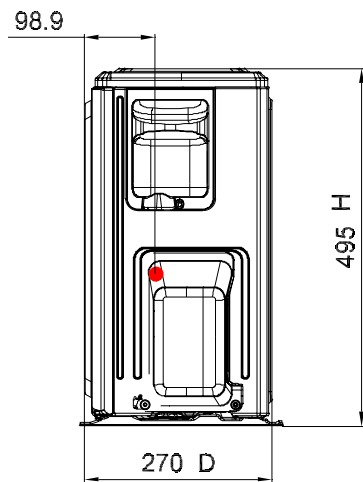

18k

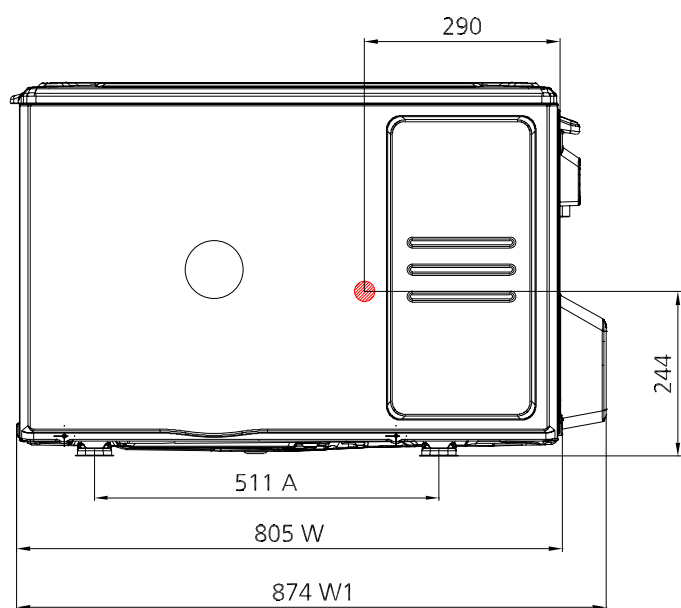
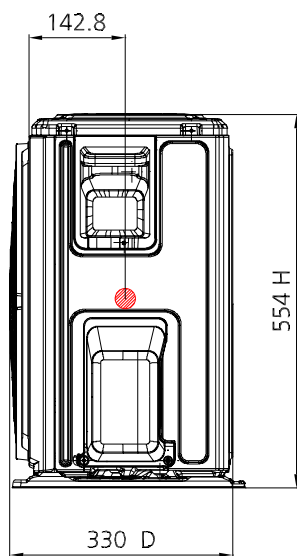

24k

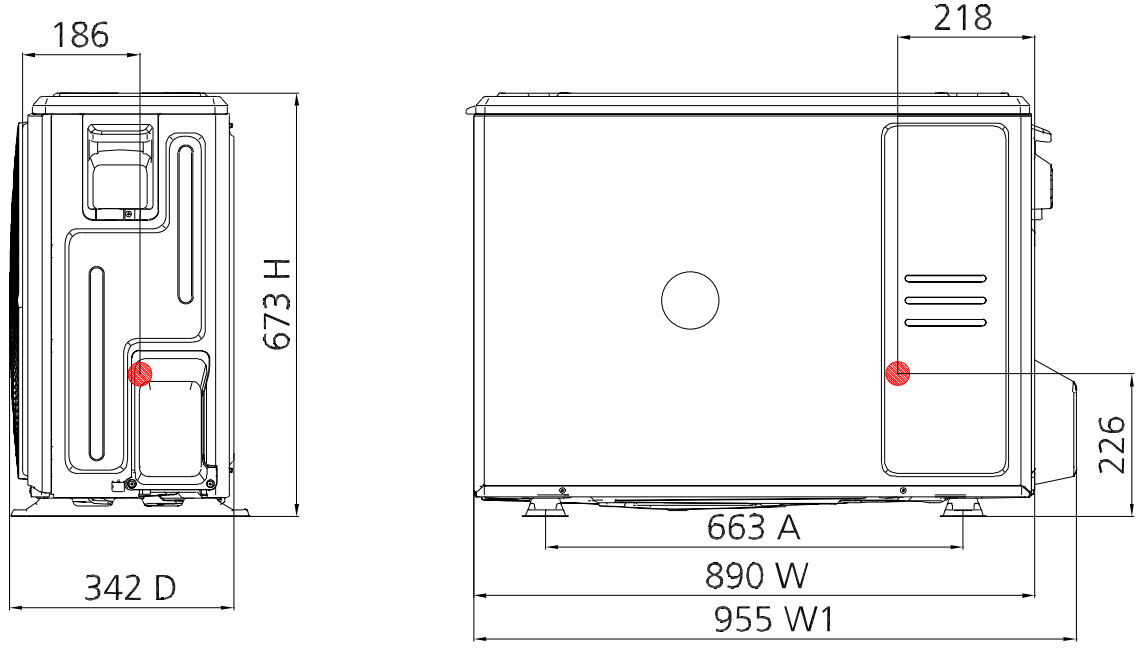

5. Electrical Wiring Diagrams

5.1 Indoor unit

Abbreviation	Paraphrase
Y/G	Yellow-Green Conductor
ION	Positive and Negative Ion Generator
CAP	Capacitor
PLASMA	Electronic Dust Collector
L	LIVE
N	NEUTRAL

9k~24k

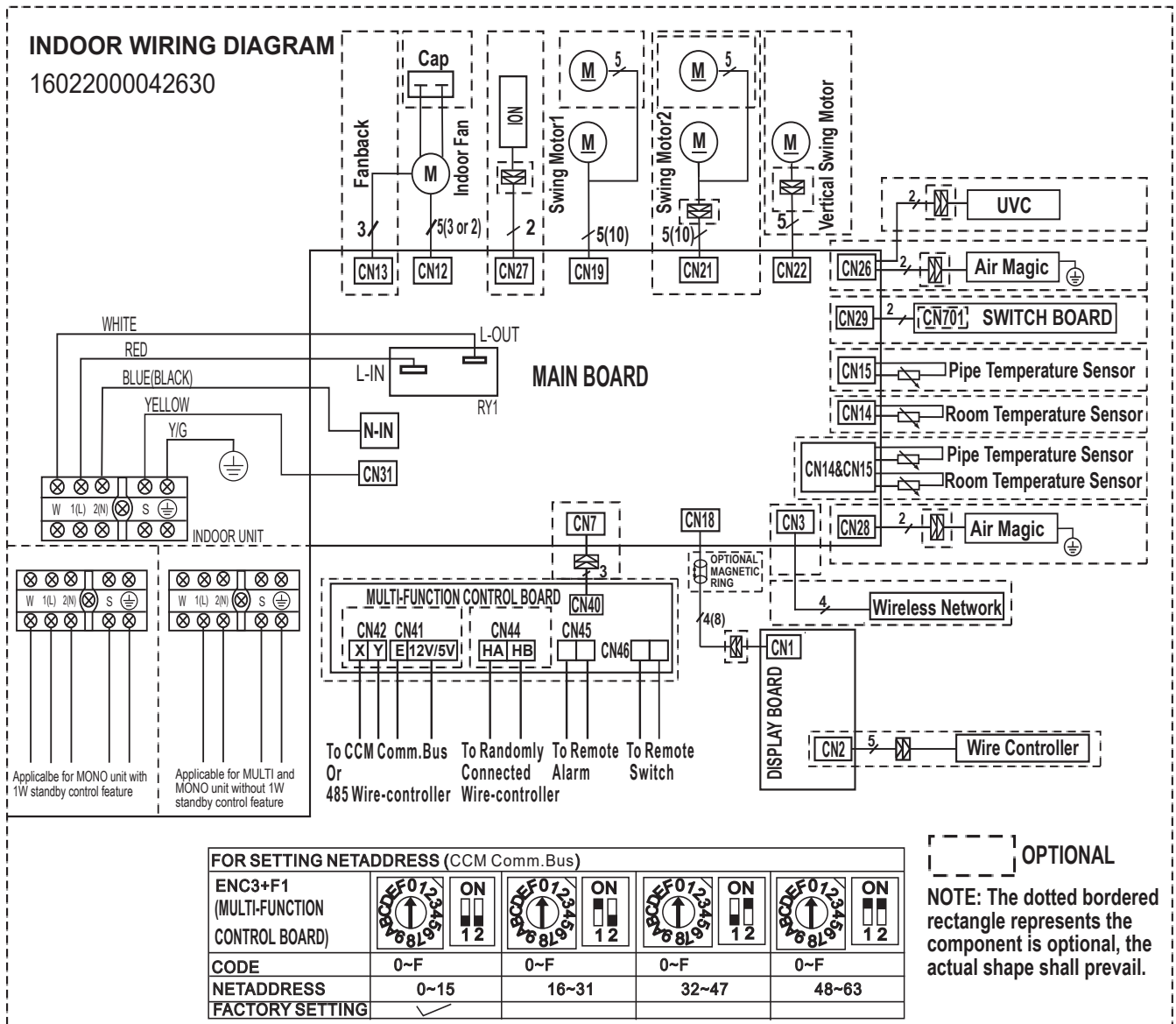

5.2 Outdoor Unit

Abbreviation	Paraphrase
4-WAY	Gas Valve Assembly/4-WAY VALVE
AC-FAN	Alternating Current FAN
DC-FAN	Direct Current FAN
COMP	Compressor

9k~24k

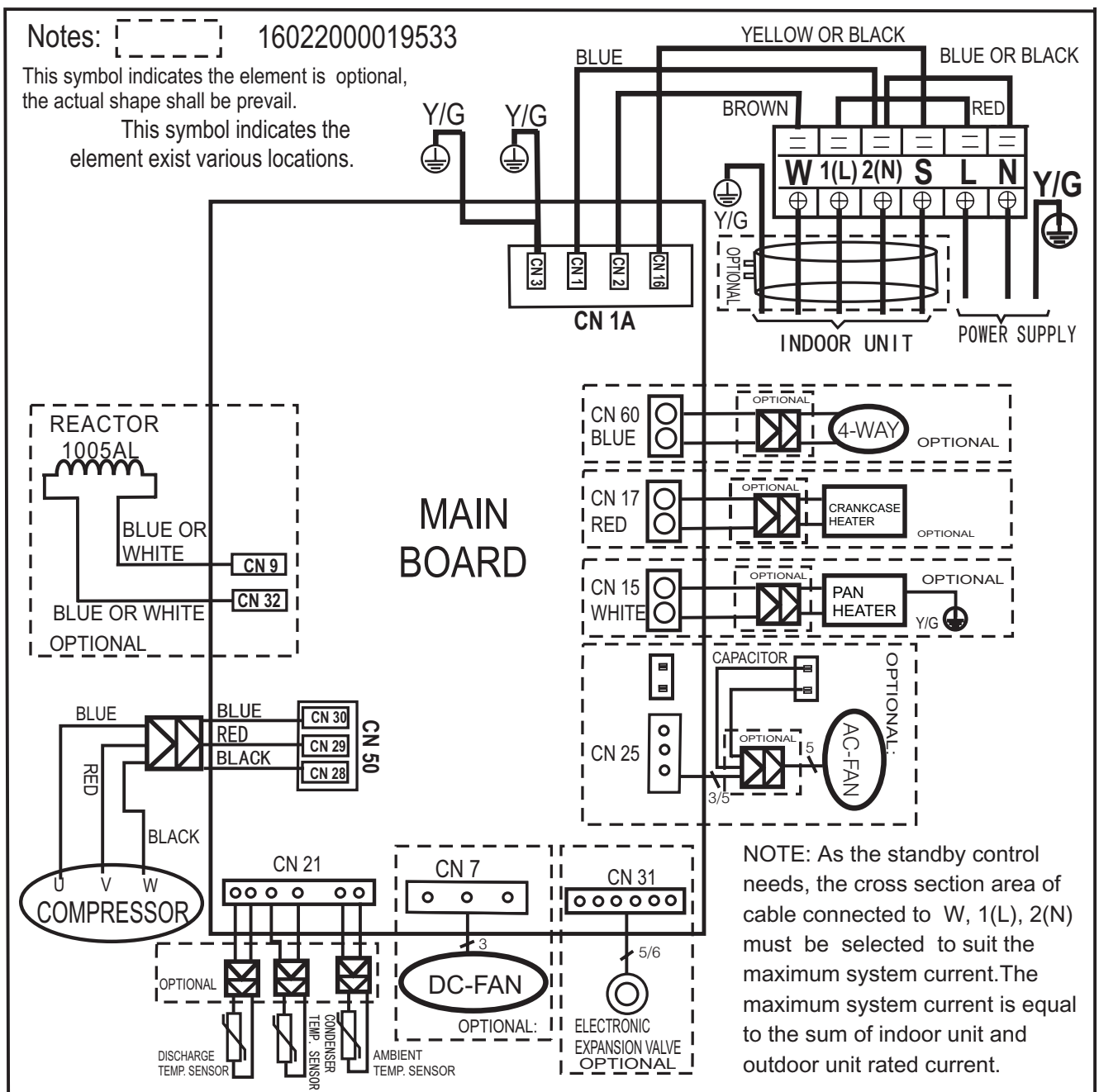

6. Refrigerant Cycle Diagrams

9k/12k

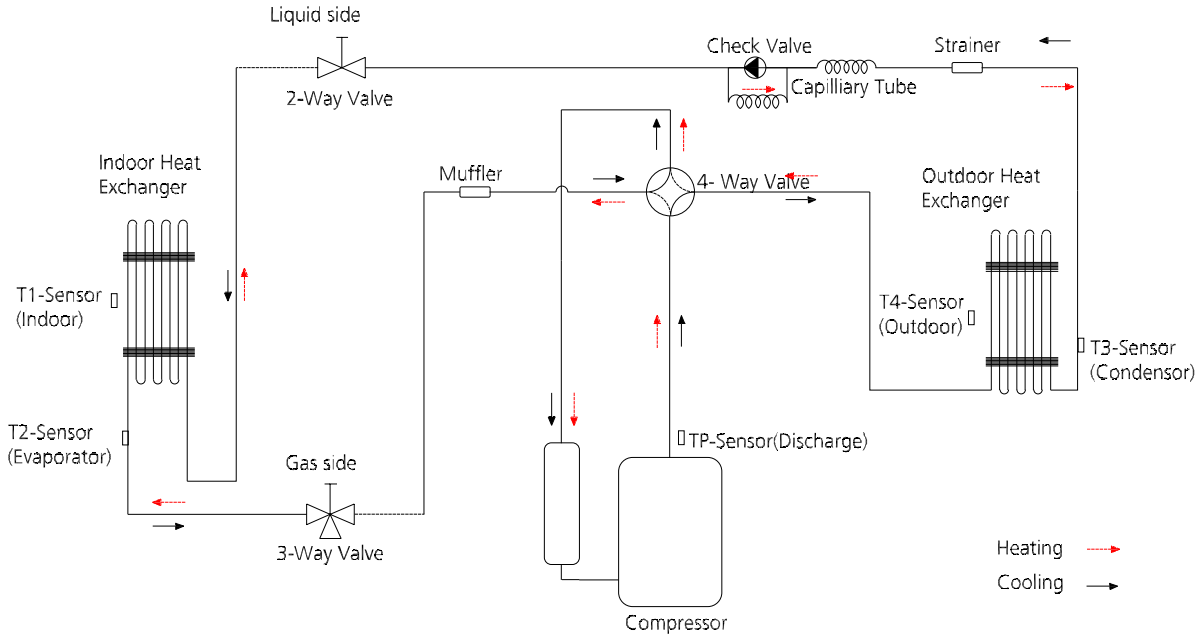

18k

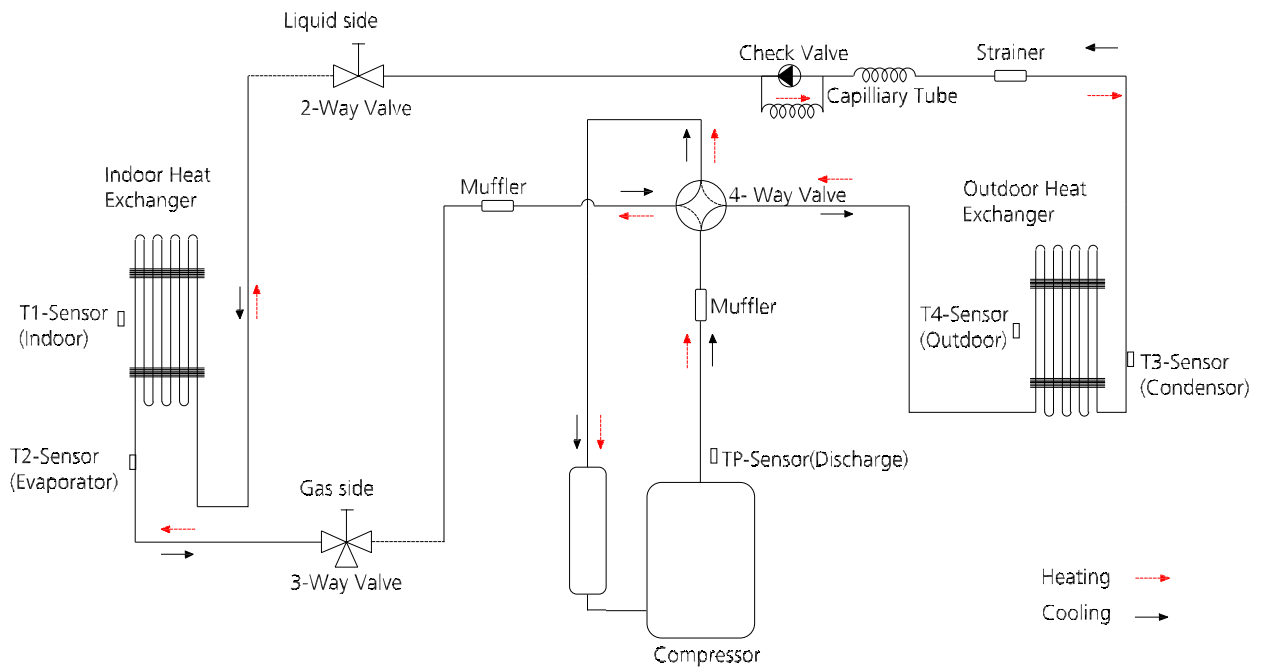

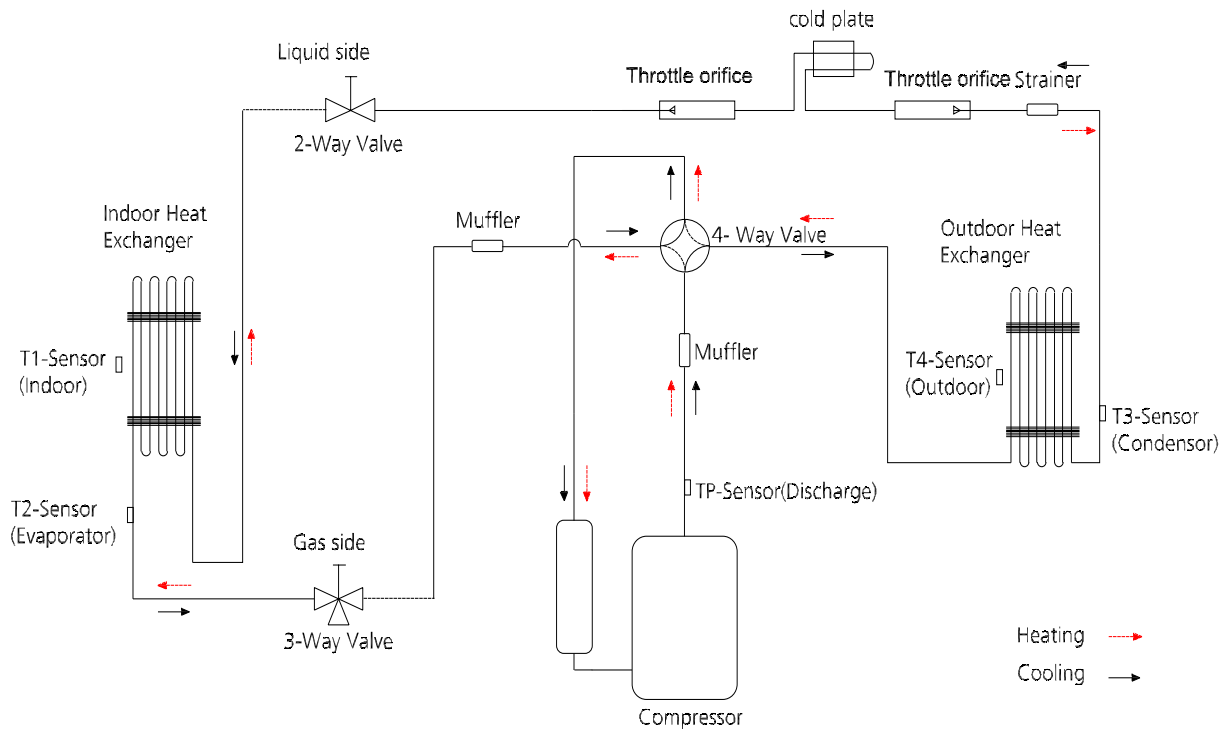

7. Noise Criterion Curves

7.1 Indoor Unit

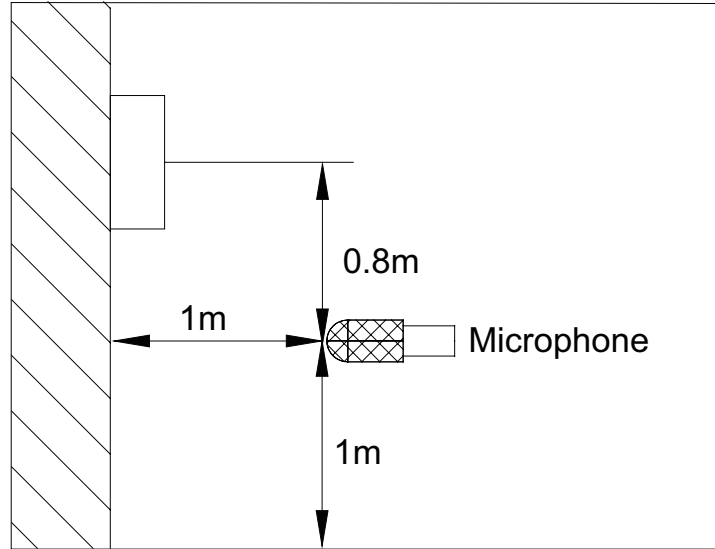

Notes:

- Sound measured at 1.0m away from the center of the unit.
- Data is valid at nominal operation condition
- Reference acoustic pressure $OdB = 20\mu Pa$
- Sound level will vary depending on a range of factors such as the construction -(acoustic absorption coefficient) of particular room in which the equipment is installed.
- The operating conditions are assumed to be standard.

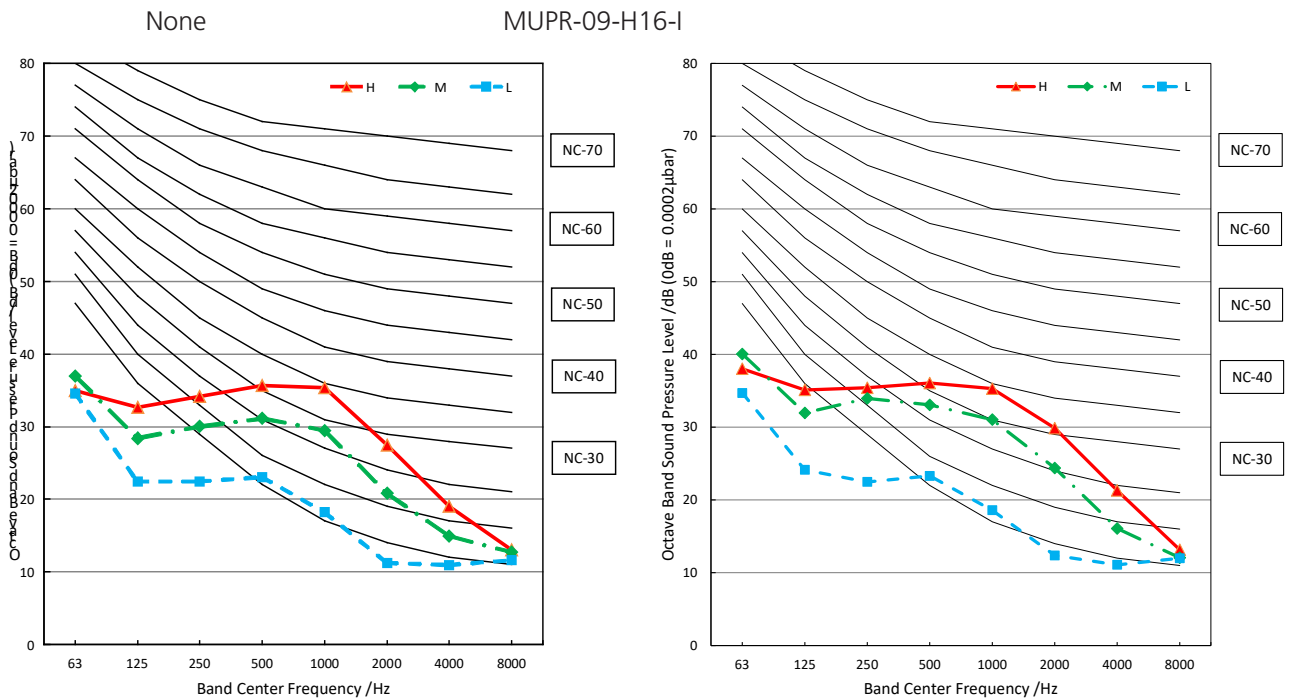

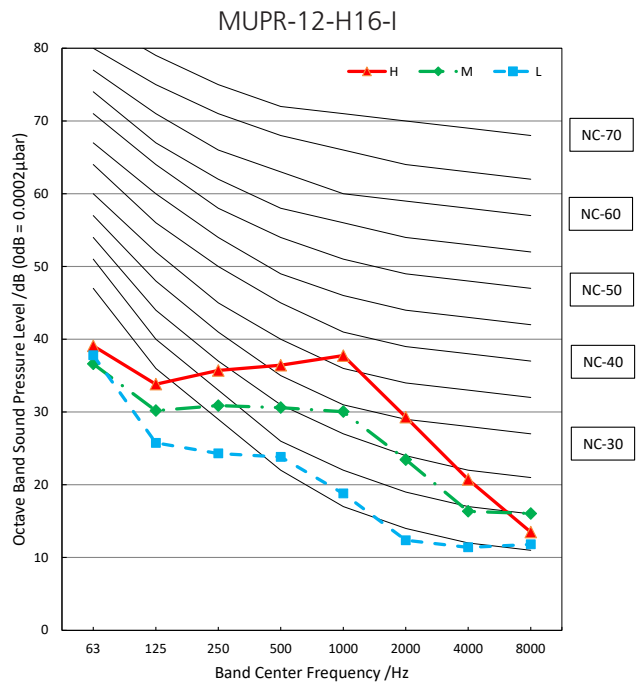
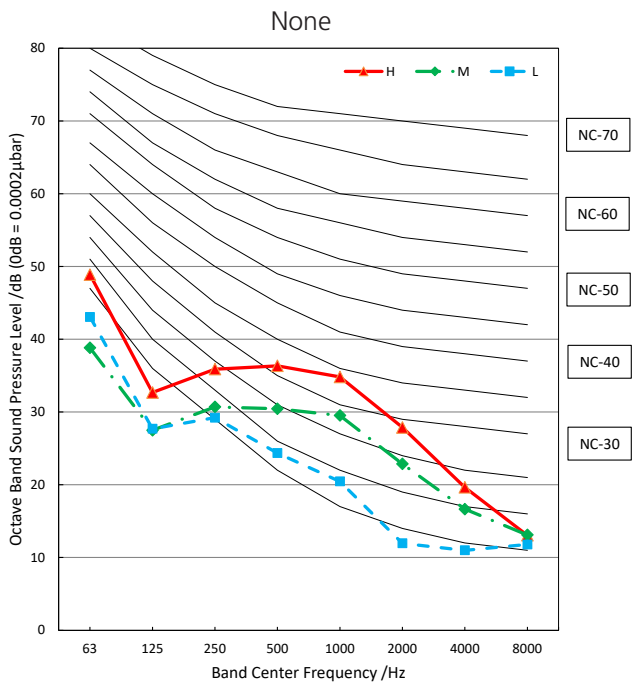
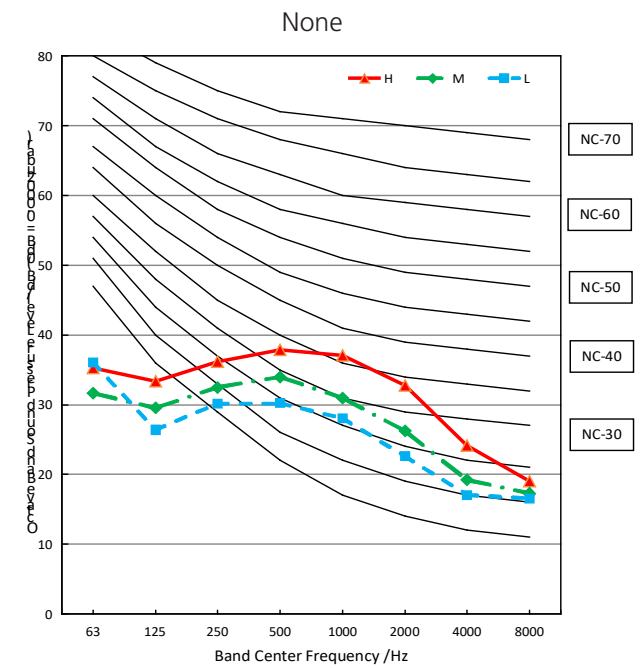
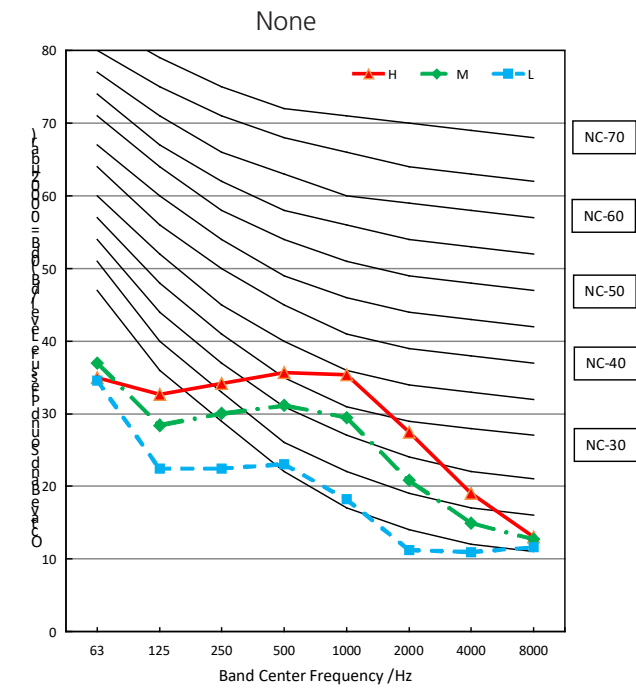

MUPR-18-H16-I

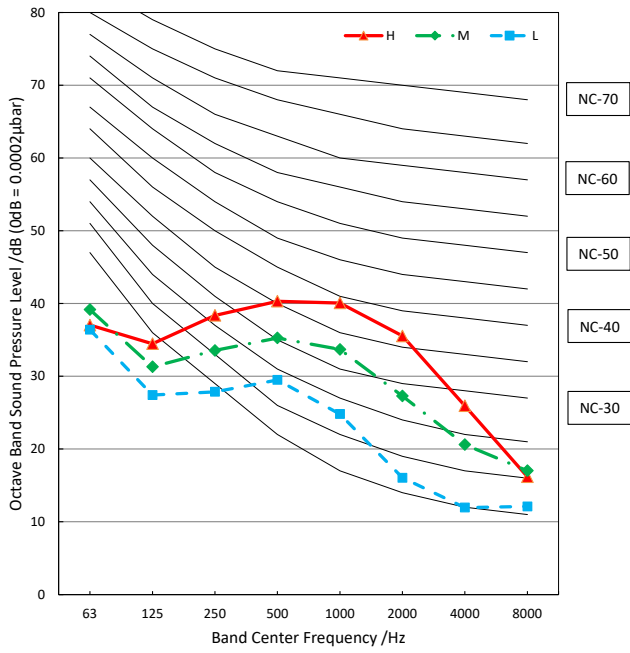

MUPR-24-H16-I

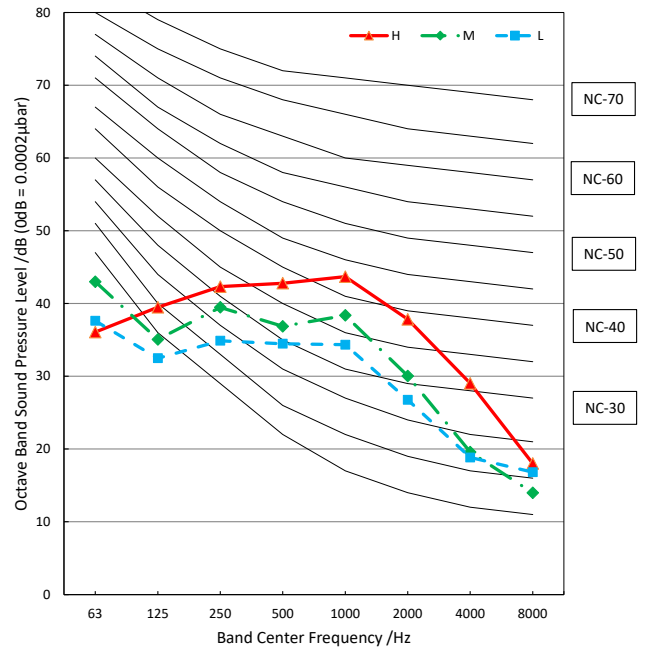

7.2 Outdoor Unit

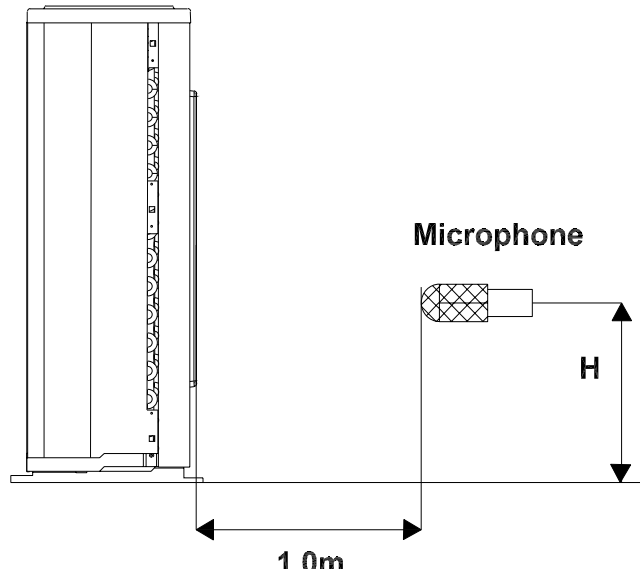

Note: $H = 0.5 \times \text{height of outdoor unit}$

Notes:

- Sound measured at 1.0m away from the center of the unit.
- Data is valid at free field condition
- Data is valid at nominal operation condition
- Reference acoustic pressure $OdB=20\mu Pa$
- Sound level will vary depending on arrange off actors such as the construction (acoustic absorption coefficient) of particular room in which the equipment is installed.
- The operating conditions are assumed to be standard.

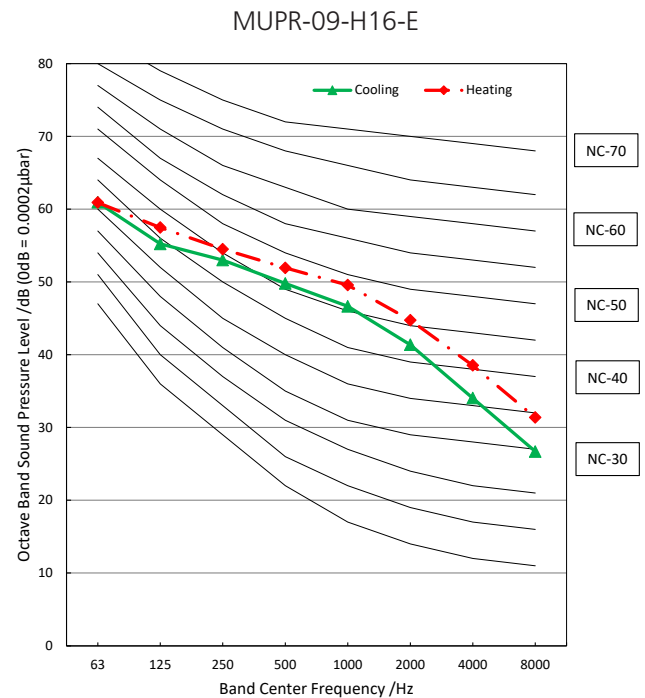
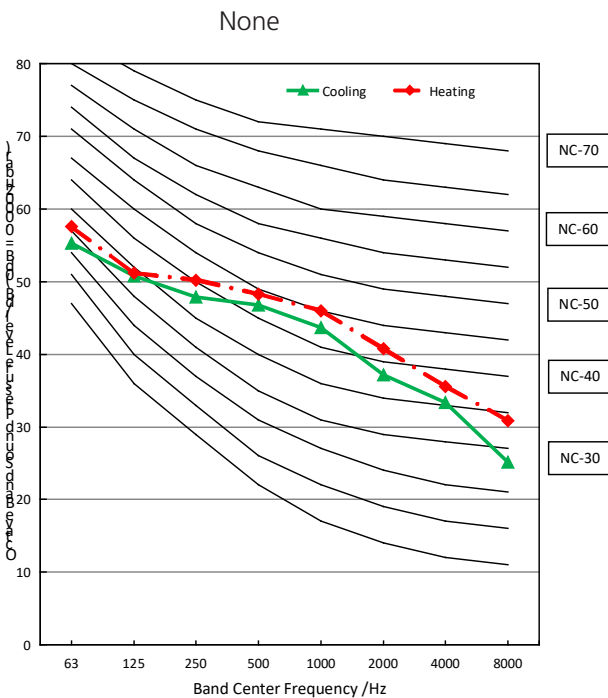

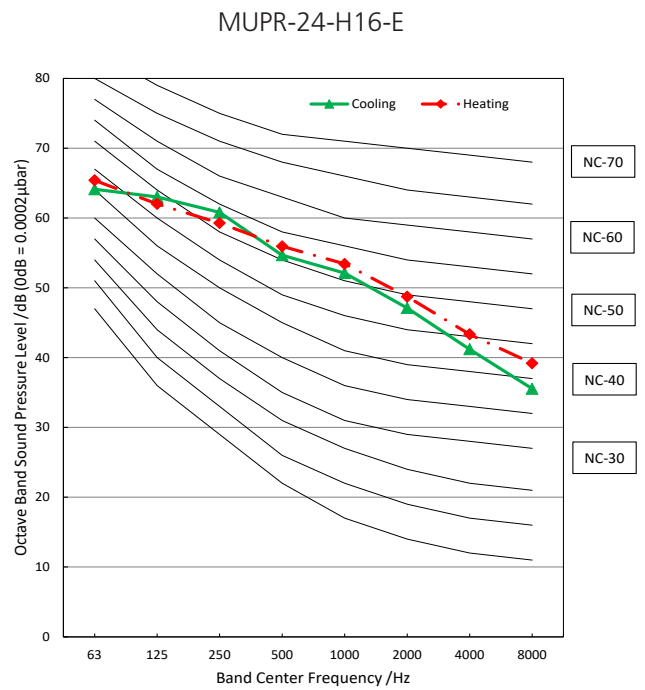
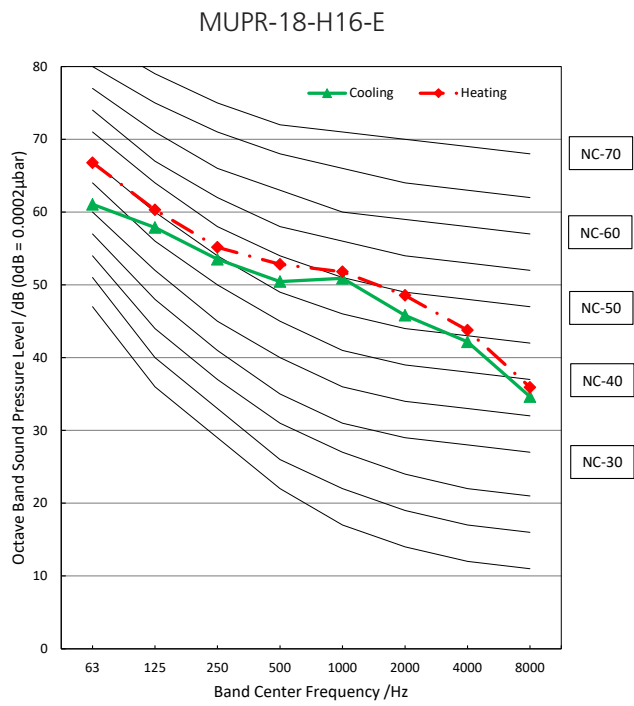
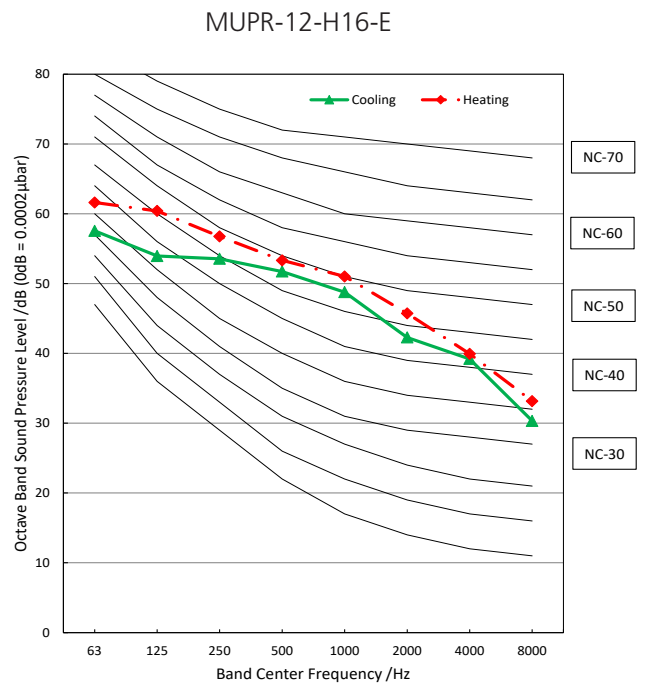
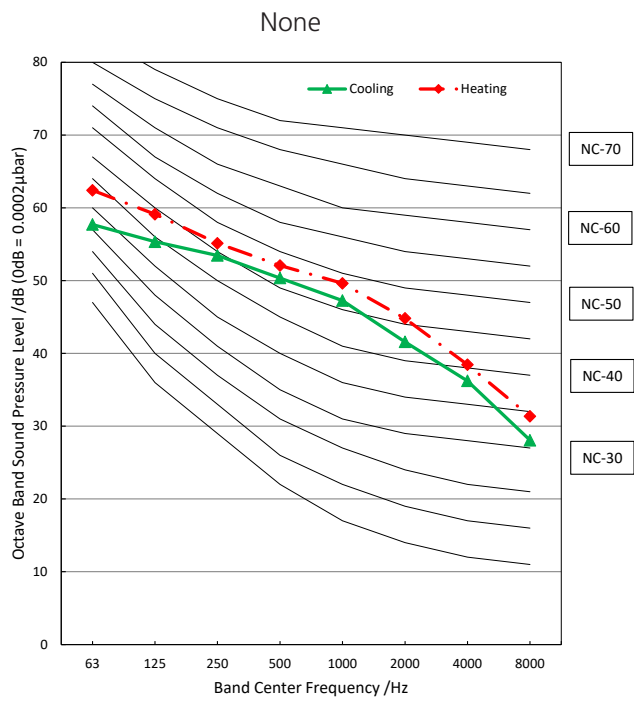

Heating(ID: 20°C/68°F, OD: 7°C/44.6°F)

Discharge Angle 65°

Airflow velocity distributions

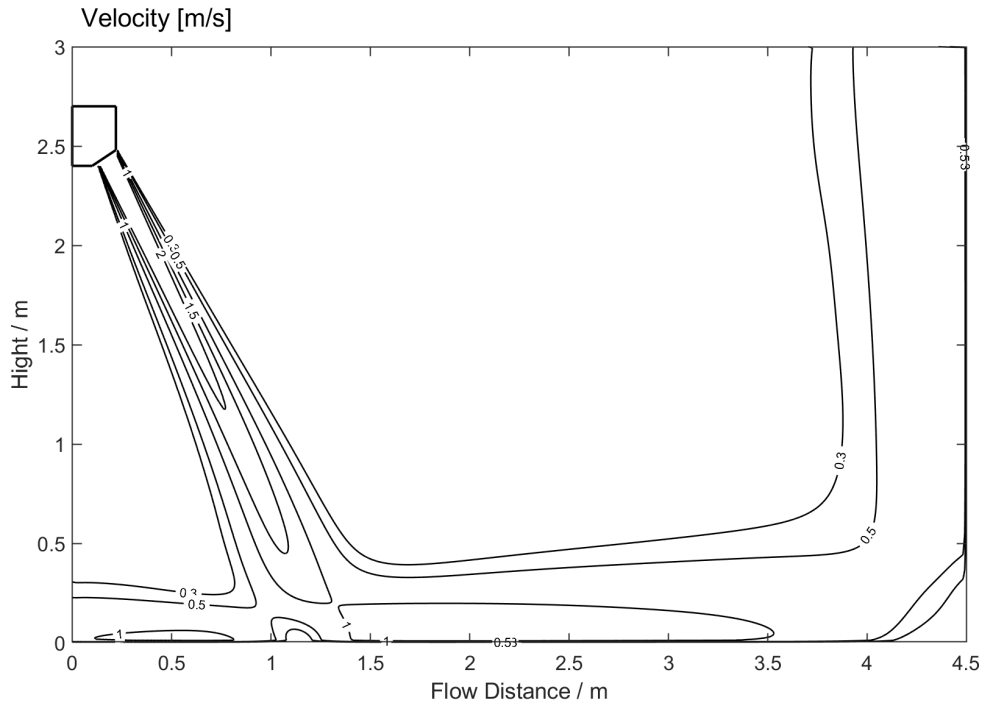

Temperature distributions

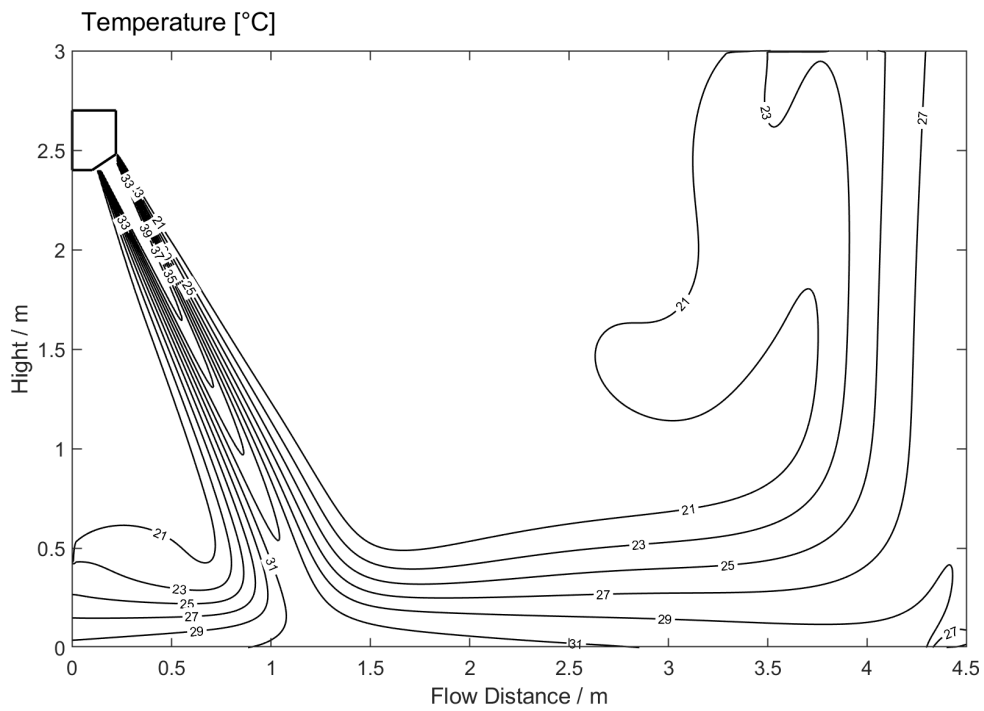

12k

Cooling(ID: 27°C/80.6°F, OD: 35°C/95°F)

Discharge Angle 20°

Airflow velocity distributions

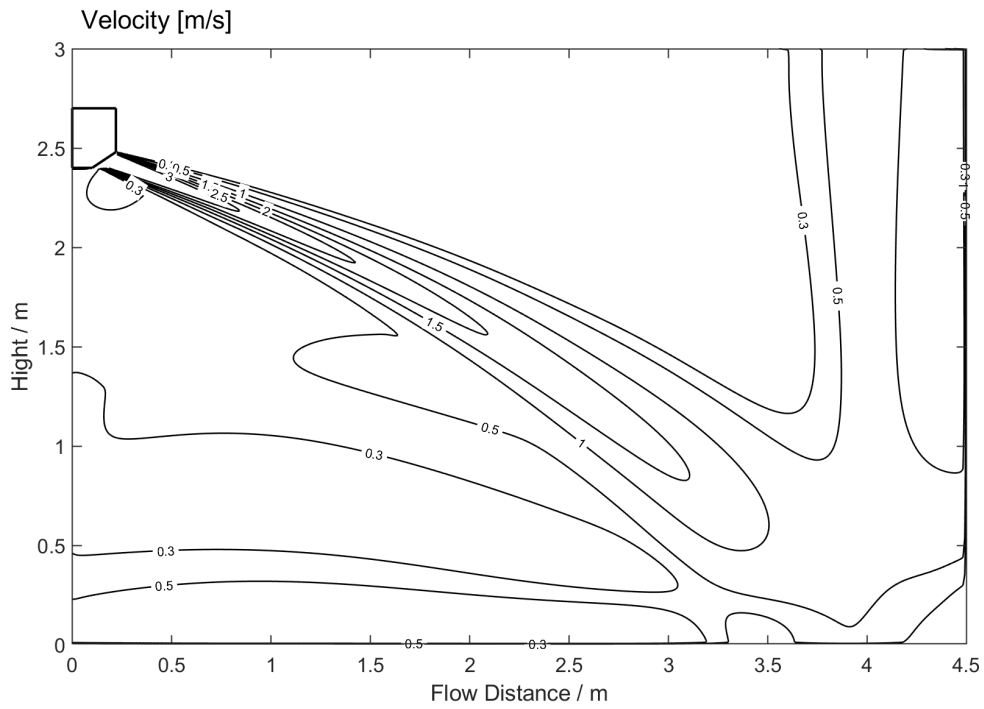

Temperature distributions

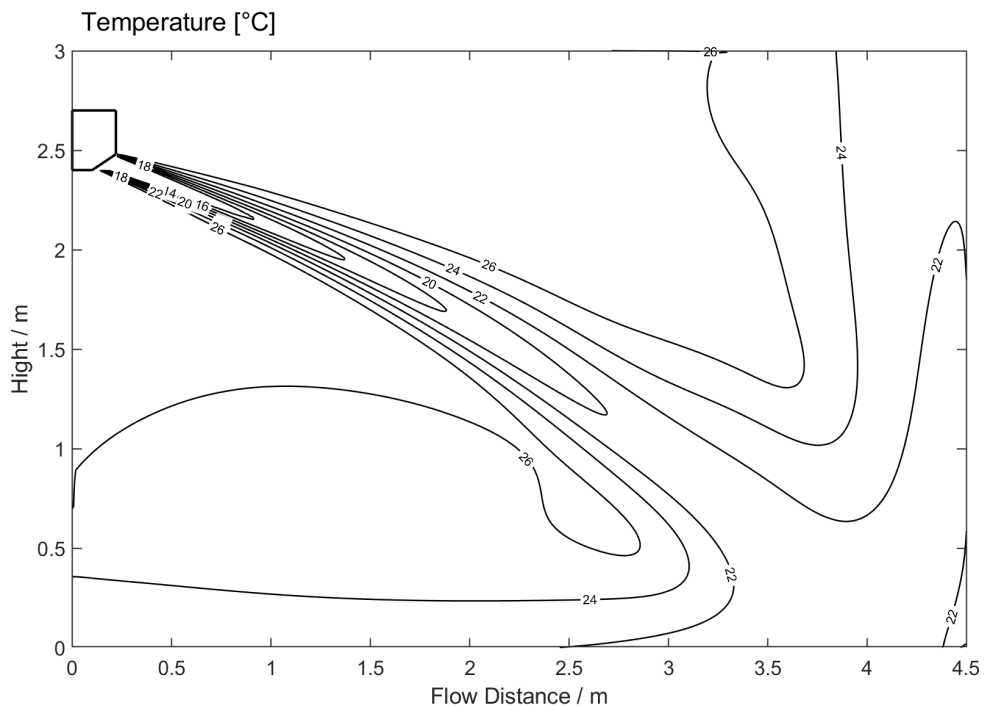

Heating(ID: 20°C/68°F, OD: 7°C/44.6°F)

Discharge Angle 65°

Airflow velocity distributions

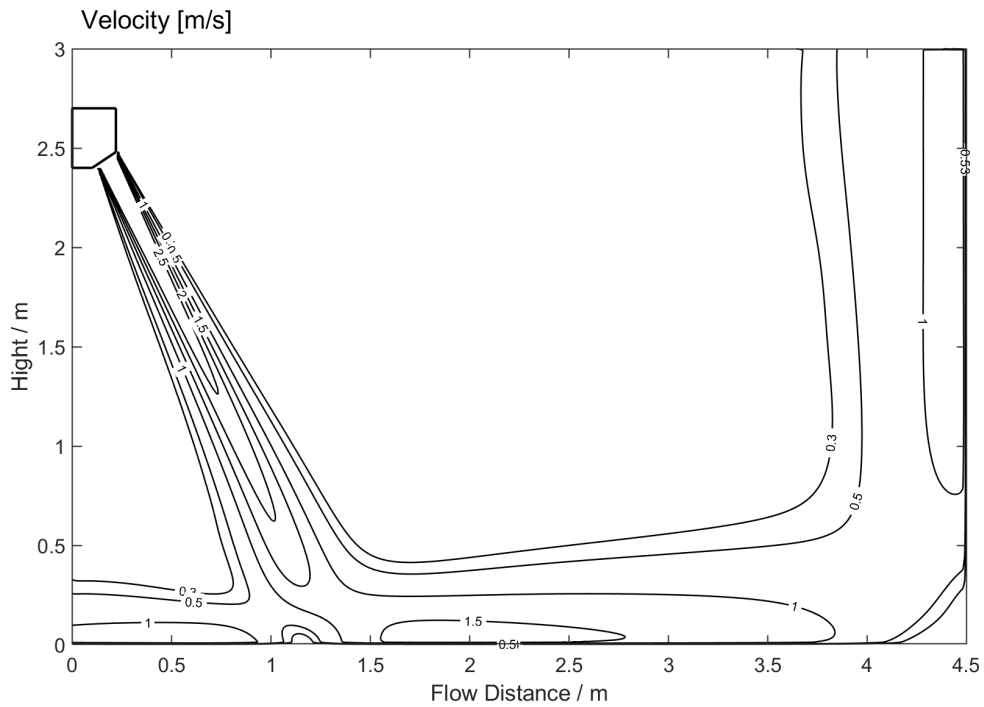

Temperature distributions

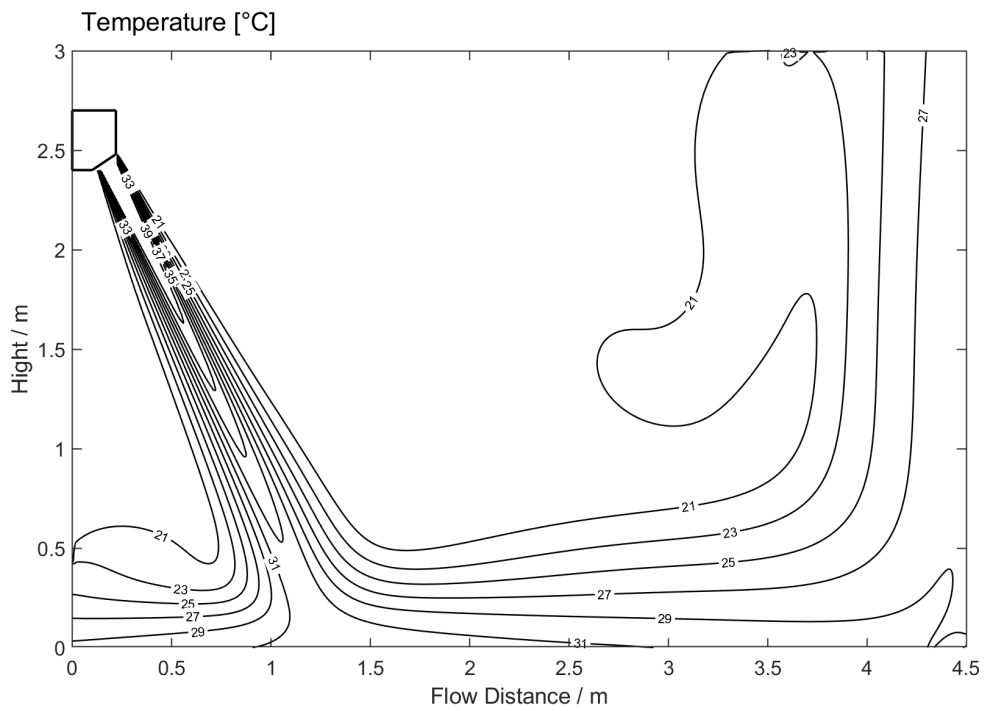

18k

Cooling(ID: 27°C/80.6°F, OD: 35°C/95°F)

Discharge Angle 18°

Airflow velocity distributions

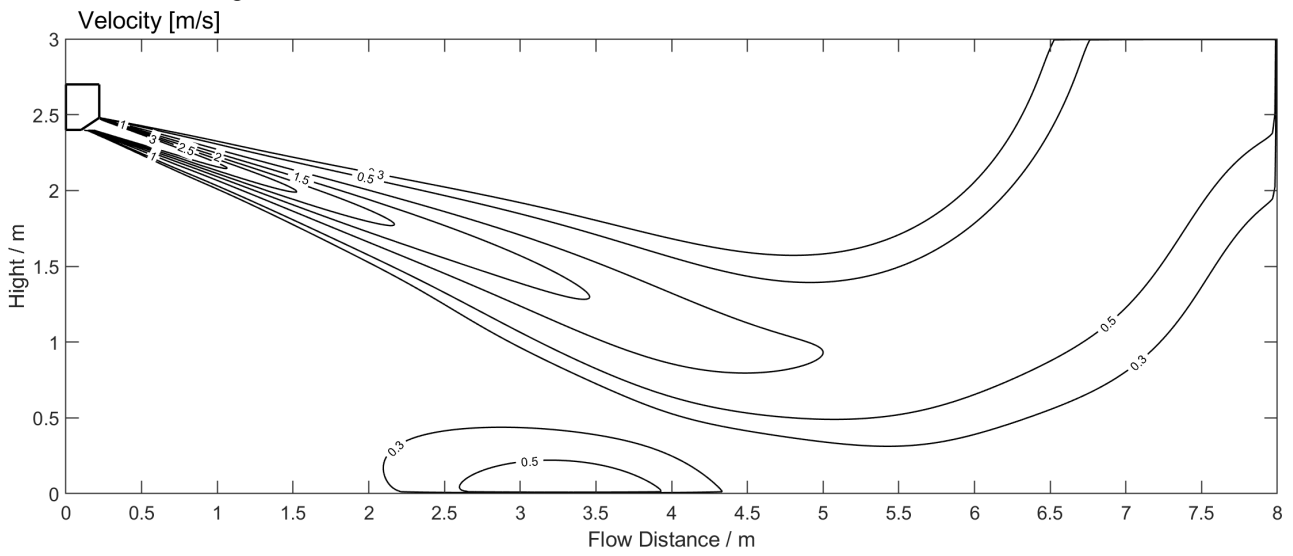

Temperature distributions

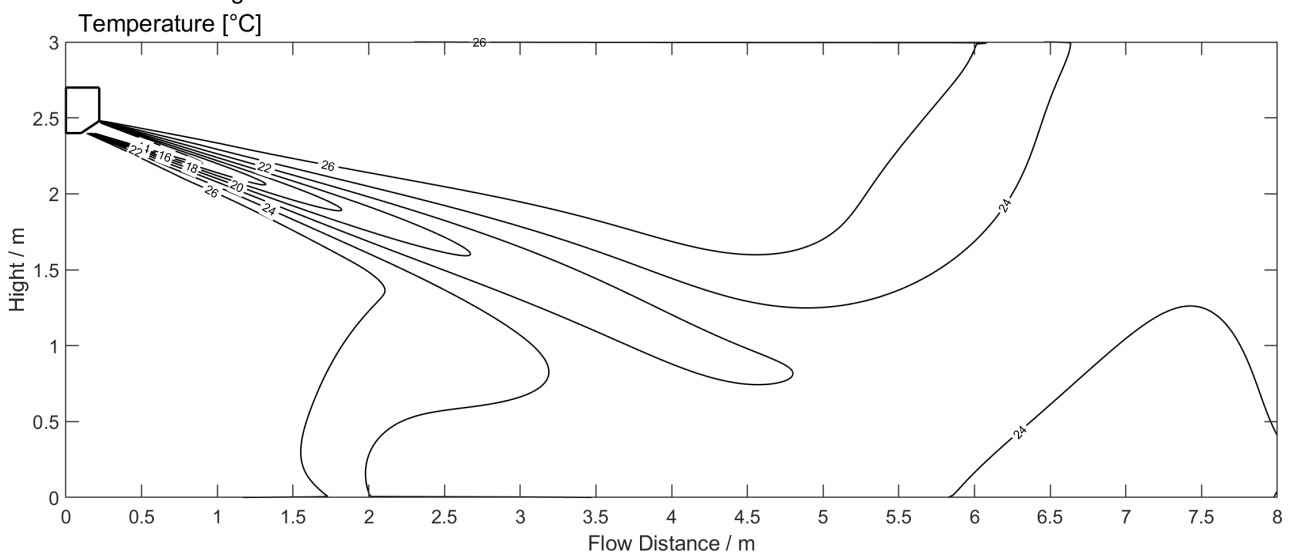

Heating(ID: 20°C/68°F, OD: 7°C/44.6°F)

Discharge Angle 62°

Airflow velocity distributions

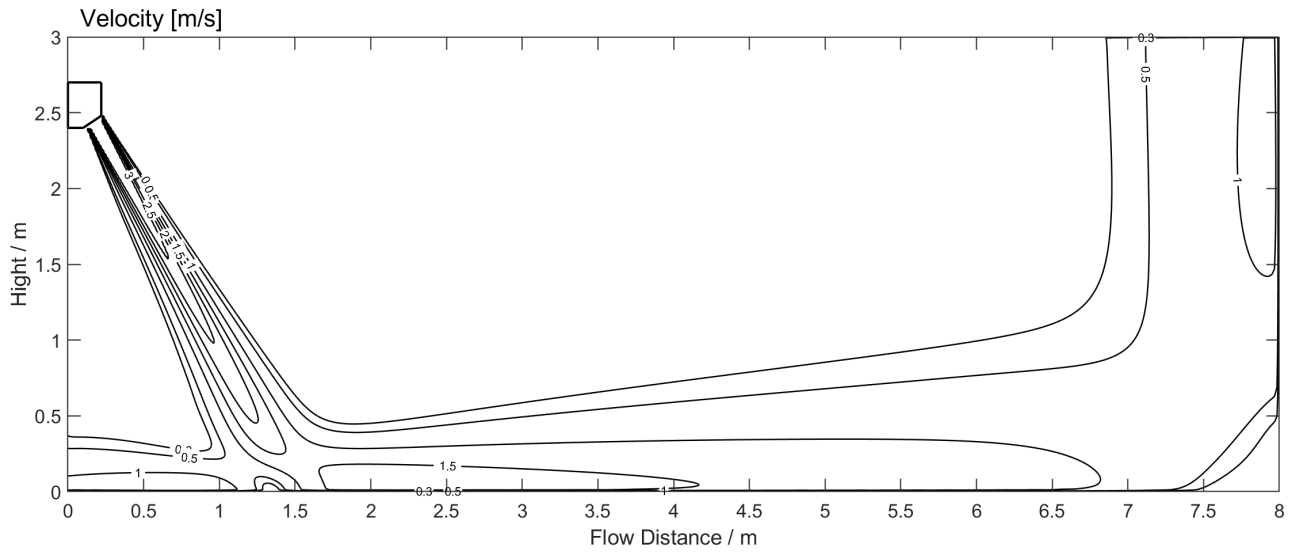

Temperature distributions

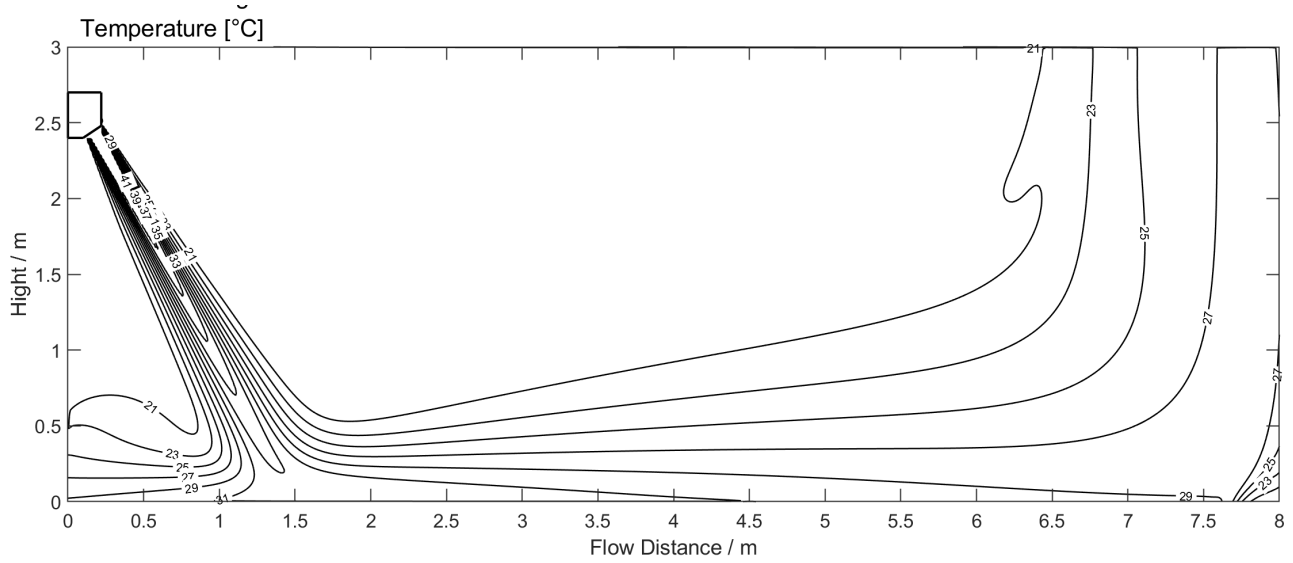

24k

Cooling(ID: 27°C/80.6°F, OD: 35°C/95°F)

Discharge Angle 20°

Airflow velocity distributions

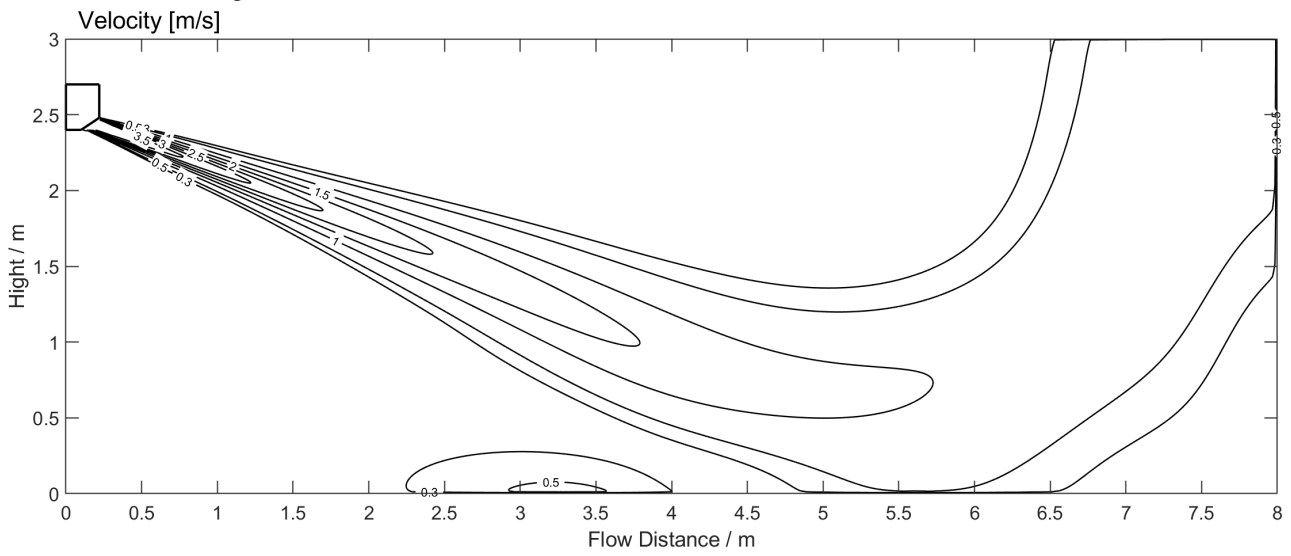

Temperature distributions

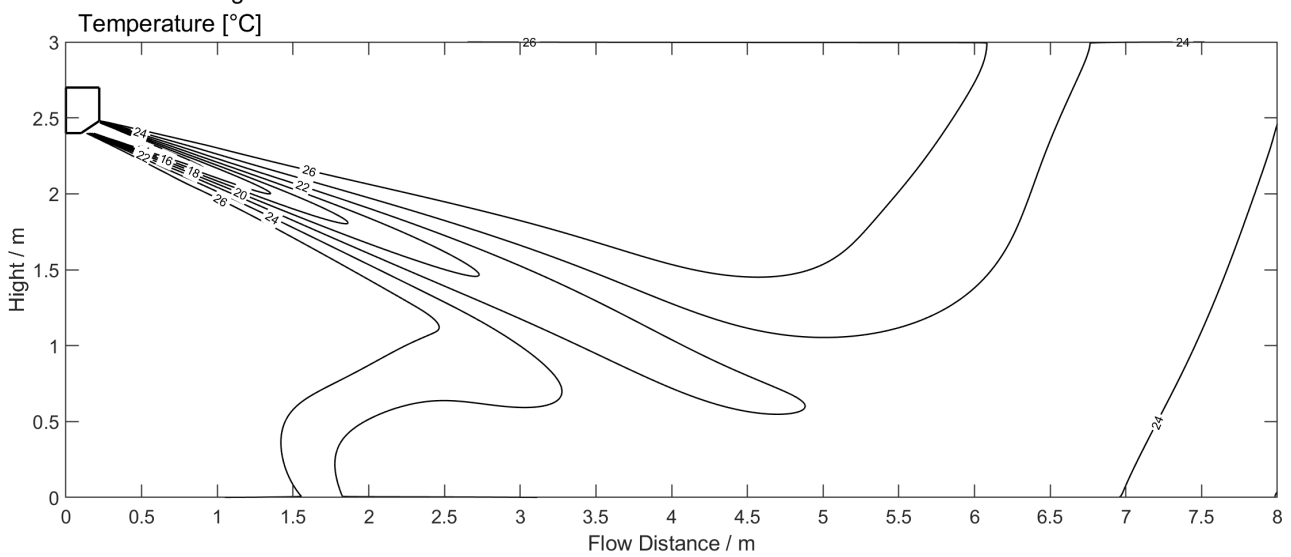

Heating(ID: 20°C/68°F, OD: 7°C/44.6°F)

Discharge Angle 68°

Airflow velocity distributions

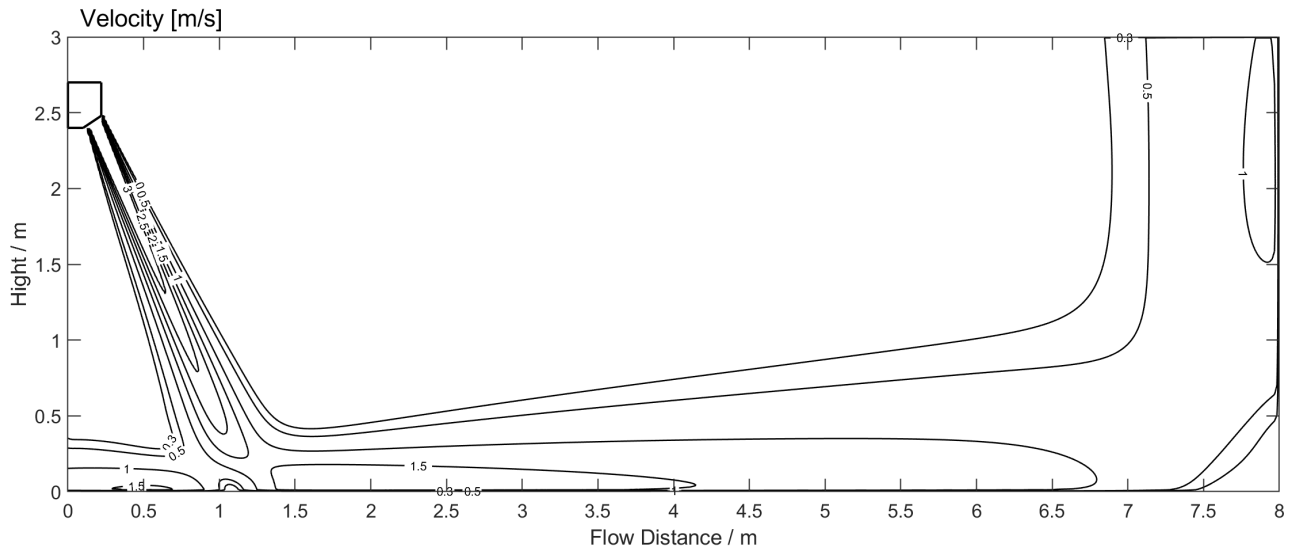

Temperature distributions

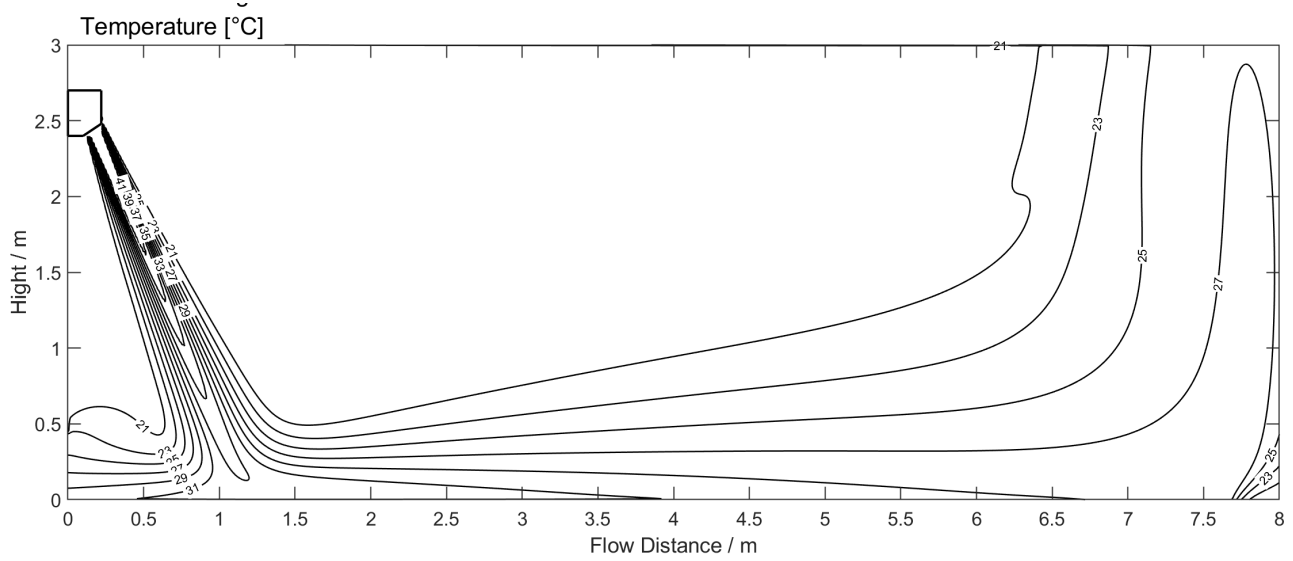

MUNDO  CLIMA®



C/ ROSSELLÓ, 430-432
08025 BARCELONA
ESPAÑA / SPAIN
(+34) 93 446 27 80
SAT: (+34) 93 652 53 57

www.mundoclima.com