

# DHW SPLIT HEAT PUMP

Installation & Owner's manual  
and information requirements

## MUACSB-H16

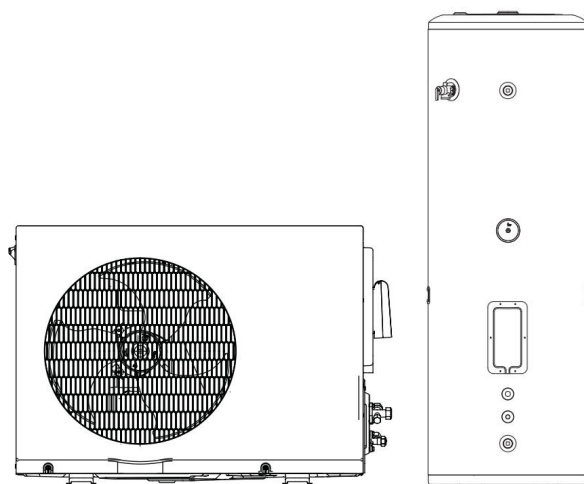



# CONTENTS

<b>1 SAFETY PRECAUTIONS</b> .....	01
<b>2 GENERAL INTRODUCTION</b> .....	09
2.1 Outdoor unit .....	09
2.2 Water tank .....	09
2.3 Specifications .....	10
<b>3 BEFORE INSTALLATION</b> .....	11
3.1 Accessories .....	11
3.2 Space .....	11
<b>4 INSTALLATION PROCEDURE</b> .....	13
4.1 Dimension and mounting .....	13
4.2 Drain hole position .....	14
4.3 Pipe connection.....	15
4.4 Wire Controller Installation .....	17
4.5 Vacuum Drying.....	17
4.6 Refrigerant charge .....	18
<b>5 ELECTRICAL CONNECTION</b> .....	19
5.1 Power supply cords.....	19
5.2 Water tank temperature sensor installation.....	19
5.3 Outdoor unit & AUX. power connection.....	20
5.4 Dip switch settings .....	21
<b>6 OPERATION INSTRUCTIONS</b> .....	21
6.1 Start up .....	21
6.2 Wired controller operation .....	22
<b>7 CONNECTING TO NETWORK</b> .....	35
<b>8 OPERATIONS</b> .....	36
<b>9 SERVICE AND MAINTENANCE</b> .....	37
9.1 Confirmation before running.....	40
9.2 Trouble shooting when abnormal situation happens.....	40
9.3 After-sale service .....	40
9.4 Important information for the used refrigerant.....	40
9.5 Water quality limitations .....	41
9.6 About maintenance .....	42

# 1 SAFETY PRECAUTIONS

Observe the basic safety regulations before starting work and operation.

## DANGER

It indicates a hazard with a high level of risk which, if not avoided, will result in death or serious injury.

## WARNING

It indicates a hazard with a medium level of risk which, if not avoided, could result in death or serious injury.





## CAUTION

It indicates a hazard with a low level of risk which, if not avoided, could result in minor or moderate injury.

## NOTE

Additional information.

## Symbols on the unit

	WARNING	Flammable refrigerant is applied. A fire may occur due to unexpected leakage of refrigerant.
	CAUTION	Read the operation manual carefully before any further action.
	CAUTION	Only a specialist is allowed to take action under the instructions of the installation manual.
	CAUTION	The information is available in the relevant documentation.

## Target group

### DANGER

These instructions are exclusively intended for qualified contractors and authorized installers.

- Work on the refrigerant circuit with flammable refrigerant in safety group A2L may only be carried out by authorized heating contractors. These heating contractors must be trained in accordance with EN 378 Part 4 or IEC 60335-2-40, Section HH. The certificate of competence from an industry accredited body is required.

- Brazing/soldering work on the refrigerant circuit may only be carried out by personnel certified in accordance with ISO 13585 and AD 2000, Datasheet HP 100R. And only contractors qualified and certified for the processes can perform brazing/soldering work. The work must fall within the range of applications purchased and be carried out in accordance with the prescribed procedures. Soldering/brazing work on accumulator connections requires certification of personnel and processes by a notified body according to the Pressure Equipment Directive (2014/68/EU).
- Work on electrical equipment may only be carried out by a qualified electrician.
- Before initial commissioning, all safety-related points must be checked by the particular certified heating contractors. The system must be commissioned by the system installer or a qualified person authorized by the installer. Every working procedure that affects safety means shall only be carried out by competent persons. All operators or refrigeration circuit maintenance personnel should obtain valid certificates issued by industry recognized evaluation agencies to recognize their qualifications for safe disposal of refrigerants as required by industry recognized evaluation standards.

## Intended use

The appliance is classified as appliance accessible to the general public.

There is a risk of injury or death to the user or others, or of damage to the product and other property in the event of improper or unintended use.

The product is the outdoor unit of an air-to-water heat pump with monoblock design.

The product uses the outdoor air as a heat source and can be used to heat a residential building and generate domestic hot water.

The air that escapes from the product must be able to flow out freely, and must not be used for any other purposes.

The product is only intended for outdoor installation.

The product is intended exclusively for domestic use, which means that the following places are not appropriate for installation:

- Where there is mist of mineral oil or oil spray or vapors. Plastic parts may deteriorate, and cause joint loose and leakage of water.
- Where corrosive gases (such as sulfurous acid gas) are produced, or corrosion of copper pipes or soldered parts may cause leakage of refrigerant.
- Where there is machinery which emits massive electromagnetic waves. Enormous electromagnetic waves can disturb the control of the system and cause equipment malfunction.
- Where flammable gases may leak, carbon fiber or ignitable dust is suspended in the air or volatile flammables such as paint thinner or gasoline are handled. These types of gases might cause a fire.
- Where the air contains high levels of salt such as a location near the ocean.
- Where voltage fluctuates a lot, such as a location in a factory.
- In vehicles or vessels.
- Where acidic or alkaline vapors are present.

Intended use includes the following:

- Observance of the operating instructions included for the product and any other installation components.
- Compliance with all inspection and maintenance conditions listed in the instructions.
- Installing and setting up the product in accordance with the product and system approval.
- Installation, commissioning, inspection, maintenance and troubleshooting by qualified contractors and authorized installers. Intended use also covers installation in accordance with the IP code.

This appliance can be used by children aged from 8 years and above and persons with reduced physical, sensory or mental capabilities or lack of experience and knowledge provided that they have been given supervision or instruction concerning the use of the appliance in a safe way and understand the hazards involved. Children should not play with the appliance. Cleaning and user maintenance shall not be made by children. This appliance is not intended for use by persons (including children) with reduced physical, sensory or mental capabilities, or lack of experience and knowledge, unless they have been given supervision or instruction concerning use of the appliance by a person responsible for their safety. Any other use that is not specified in these instructions, or use beyond that specified in this document, should be considered as improper use.

Any direct commercial or industrial use is also deemed to be improper.

Children should be supervised to ensure that they do not play with the appliance.

### CAUTION

Improper use of any kind is prohibited.

- Do not rinse the unit.
- Do not place any object or equipment on top of the unit (top plate).
- Do not climb, sit or stand on top of the unit.

## Regulations to be observed

- 1) National installation regulations.
- 2) Statutory regulations for the prevention of accidents.
- 3) Statutory regulations for environmental protection.
- 4) Statutory requirements for pressure equipment: Pressure Equipment Directive 2014/68/EU.
- 5) Codes of practice of the relevant trade associations.
- 6) Relevant country-specific safety regulations.
- 7) Applicable regulations and guidelines for operation, service, maintenance, repair and safety of cooling, air conditioning and heat pump systems containing flammable and explosive refrigerant.

## Safety instructions for working on the system

The outdoor unit contains flammable refrigerant R454C. In case of a leak, the escaping refrigerant may form a flammable or explosive atmosphere in the ambient air. A safety zone is defined in the immediate vicinity of the outdoor unit, in which special rules apply when work is performed on the appliance. See section "Safety zone".

## Working in the safety zone

### DANGER

Risk of explosion: Refrigerant leak may form a flammable or explosive atmosphere in the ambient air. Ducts connected to an appliance shall not contain a potential ignition source.

Take the following measures to prevent fire and explosion in the safety zone:

- Keep ignition sources away, including naked flames, plug sockets, hot surfaces, light switches, lamps, electrical devices not free of ignition sources, mobile devices with integrated batteries (such as mobile phones and fitness watches).
- Do not use any sprays or other combustible gases in the safety zone.

### CAUTION

Permissible tools: All tools for working in the safety zone must be designed and explosion-protected in accordance with the applicable standards and regulations for refrigerant in safety groups A2L and A3, such as brushless machines (cordless disposal containers, installation aids, and screwdrivers), extraction equipment, vacuum pumps, conductive hoses, and mechanical tools of non-sparking material.

### CAUTION

The tools must also be suitable for the pressure ranges in use. Tools must be in perfect maintenance conditions.

- The electrical equipment must meet the requirements for areas at risk of explosion, zone 2.
- Do not use flammable materials such as sprays or other flammable gases.
- Before starting work, discharge static electricity by touching earthed objects, such as heating or water pipes.
- Do not remove, block or bridge safety equipment.
- Do not make any changes: Do not modify the outdoor unit, inlet/outlet lines, electrical connections/cables or the surroundings. Do not remove any components or seals.

## Working on the system

Switch off the power supply for the unit (including all affiliated parts) at a separate fuse or mains isolator. Check and ensure that the system is no longer live.

### CAUTION

In addition to the control circuit there may be several power circuits.

## DANGER

Contact with live components can result in severe injuries. Some components on PCBs remain live even after the power supply has been switched off. Prior to removing covers from the appliances, wait at least 4 minutes until the voltage has completely dropped out.

- Safeguard the system against reconnection.
- Wear suitable personal protective equipment when carrying out any work.
- Do not touch any switch or electrical parts with wet fingers. It may cause electrical shock and compromise the system.

## DANGER

Hot surfaces and fluids can result in burns or scalding. Cold surfaces may cause frostbite.

- Prior to servicing or maintenance tasks, switch off and allow the equipment to cool down or warm up.
- Do not touch hot or cold surfaces on the appliance, fittings or pipework.

## NOTE

Electronic assemblies can be damaged by electrostatic discharge. Before beginning work, touch earthed objects, such as heating or water pipes, to discharge any static.

Safety work area and temporary flammability zones.

## CAUTION

When working on systems using flammable refrigerants, the technician should consider certain locations as "temporary flammable zones". These are normally regions where at least some emission of refrigerant is anticipated to occur during the normal working procedures, such as recovery, charging and evacuation, typically where hoses may be connected or disconnected. The technician should ensure three meters safety working area (radius of the unit) in case of any accidental release of refrigerant that forms a flammable mixture with air.

## Working on the refrigerant circuit

R454C refrigerant (propane) is an air displacing, colorless, flammable, odorless gas which forms explosive mixtures with air. Be aware that refrigerants may not contain an odour. Refrigerant drained must be properly disposed of by authorized contractors.

- Perform the following measures before beginning work on the refrigerant circuit:
- Check the refrigerant circuit for leaks.
- Ensure very good ventilation especially in the floor area and maintain this for the duration of the work. Keep any required ventilation openings clear of obstruction.

- Secure the area surrounding the work area.
- Inform the following persons of the type of work to be carried out:
  - All maintenance personnel
  - All persons in the vicinity of the system.
- Inspect the area immediately around the heat pump for flammable materials and ignition sources: Remove all flammable materials and ignition sources.
- Before, during and after the work, check the surrounding area for escaping refrigerant using an explosion-proof refrigerant detector suitable for R454C. This refrigerant detector must not generate any sparks and must be suitably sealed.
- A CO<sub>2</sub> or powder extinguisher must be available in the following cases:
  - Refrigerant is being drained.
  - Refrigerant is being topped up.
  - Soldering or welding work is in progress.
- "No Smoking" signs shall be displayed.

## DANGER

Escaping refrigerant can lead to fires and explosions that result in very serious injuries or death.

- Do not drill or apply heat to a refrigerant circuit filled with refrigerant.
- Do not operate Schrader valves unless a fill valve or extraction equipment is attached.
- Take measures to prevent electrostatic charge.
- Do not smoke. Avoid naked flames and sparks. Never switch lights or electrical appliances on or off in environments with naked flames or sparks.
- Components that contain or contained refrigerant must be labeled, and stored in well ventilated areas in accordance with the applicable regulations and standards.

## DANGER

Direct contact with liquid or gaseous refrigerant can cause serious damage to health such as frostbite and/or burns. There is a risk of asphyxiation if liquid or gaseous refrigerant is breathed in.

- Prevent direct contact with liquid or gaseous refrigerant.
- Wear personal protective equipment when handling liquid or gaseous refrigerant.
- Never breathe in any refrigerant vapor.
- Do not pierce or burn.

## DANGER

Refrigerant is under pressure: Mechanical loading of lines and components can cause leaks in the refrigerant circuit. Do not apply loads to the lines or components, such as supporting or placing tools.

## DANGER

Hot or cold metallic surfaces of the refrigerant circuit may cause burns or frostbite in case of skin contact. Wear personal protective equipment to protect against burns or frostbite.

## NOTE

Hydraulic components may freeze during refrigerant removal. Drain heating water from the heat pump beforehand.

## DANGER

Damage to the refrigerant circuit can cause refrigerant to enter the hydraulic system. After completion of the work, vent the hydraulic system correctly. When doing so, ensure the area is sufficiently ventilated.

## Installation General

- Be sure to use only specified accessories and parts for installation. Failure to use specified parts may result in water leakage, electric shocks, fires, or the unit falling from its mount.
- Install the unit on a foundation that can withstand its weight. Insufficient physical strength may cause the unit to fall and possible injury.
- Perform specified installation work with full consideration of strong wind, hurricanes, or earthquakes. Improper installation may result in accidents due to equipment falling.
- Earth the unit and install a ground fault circuit interrupter in accordance with local regulations. Operating the unit without a proper ground fault circuit interrupter may cause electric shocks and fires.
- Install the power cable at least 3 feet (1 meter) away from televisions or radios to prevent interference or noise. (Depending on the radio waves, a distance of 3 feet (1 meter) may not be sufficient to eliminate the noise.)
- Any damaged power cord must be replaced by the manufacturer or its service agent or a similarly qualified person in order to avoid a hazard.

## CAUTION

Do not install any air vent valve in the water tank side. Make sure the outlet of the water tank safety valve leads to the outdoor side.

No ignition sources exist around the air vent valve and the outlet of safety valve.

Two situations should be considered for outdoor installations to prevent damage to the system, releases, and undesirable consequences:

- Where the equipment is located in an area accessible by members of the public, and.
- Where the equipment is located in a restricted area, with access to authorized persons only.

## DANGER



Open flames, fires, open ignition sources and smoking are prohibited.

## DANGER



Inflammable matters are prohibited.

## Freezing protection

### CAUTION

Freezing can cause damage to the heat pump.

- Thermally insulate all the hydraulic lines.
- Antifreeze can be filled in the secondary circuit in accordance with local regulations and standards.

## Connecting cables

### DANGER

With short electrical cables, should there be leakage in the refrigerant circuit, gaseous refrigerant may reach the inside of the building.

Min. length of the electrical connecting cables between the water tank and the outdoor unit: 3 m.

## Repair work

### CAUTION

Repairing components that fulfil a safety function can compromise the safe operation of the system.

- Replace faulty components only with genuine spare parts from the manufacturer.
- Do not undertake any repairs on the inverter. Replace the inverter if there is a defect.
- Repair work should not be performed in the field. Repair the unit in a specified location.
- Equipment maintenance and repair can only be carried out according to the methods recommended by the equipment manufacturer.
- Servicing shall be performed only as recommended by the manufacturer.

## Auxiliary components, spare and wearing parts

### CAUTION

Spare and wearing parts that have not been tested together with the system can compromise the function of the system. Installing non-authorized components and making non-approved modifications or conversions can compromise the safety and may invalidate our warranty. Only use original spare parts supplied or approved by the manufacturer for replacement.

## Safety instructions for operating the system

### What to do if refrigerant leaks

#### WARNING

To avoid potential risk from refrigerant leak, always keep 2 meters away from the unit, especially for kids, no matter the unit is in operation or not.

#### DANGER

Refrigerant leak can lead to fires and explosions that result in very serious injuries or death. Breathing in refrigerant may cause asphyxiation.

- Ensure very good ventilation especially in the floor area of the outdoor unit.
- Do not smoke. Avoid naked flames and sparks. Never switch lights or electrical appliances on or off in environments with naked flames or sparks.
- Evacuate any people from the dangerous zone.
- From a safe position, switch off the power supply for all system components.
- Remove ignition sources from the dangerous zone.
- The system user should know that no ignition source may be brought into the dangerous zone during the repair.
- Repair work must be carried out by an authorized contractor.
- Do not recommission the system until it is repaired.

#### CAUTION

Direct contact with liquid or gaseous refrigerant can cause serious damage to health, e.g. frostbite and/or burns. Breathing in liquid or gaseous refrigerant may cause asphyxiation.

- Prevent direct contact with liquid or gaseous refrigerant.
- Never breathe in refrigerant vapors.

### What to do if water leaks

#### DANGER

If water leaks from the appliance, an electric shock may occur. Switch off the heating system at the external isolator (e.g. fuse box, domestic distribution board).

#### DANGER

If water leaks from the appliance, scalding may occur. Never touch hot water.

## What to do if the outdoor unit ices up

#### CAUTION

A build-up of ice in the condensate pan and in the fan area of the outdoor unit can cause damage to the equipment.

- Do not use mechanical items/aids to remove ice.
- Before using electrical heating appliances, check the refrigerant circuit for leaks with a suitable measuring device. The heating appliance should not be a source of ignition, and must meet the requirements of EN 60335-2-30.
- If ice regularly builds up on the outdoor unit (e.g. in areas where frost and heavy fog occur frequently), install a fan ring heater that is suitable for refrigerant R454C and/or an electric ribbon heater in the condensate pan.

## Safety instructions for storage of the outdoor unit

The outdoor unit is charged at the factory with refrigerant R454C.

#### DANGER

Refrigerant leak can lead to fires and explosions that result in very serious injuries or death. Breathing in refrigerant may cause asphyxiation. Store the outdoor unit in the following conditions:

- An explosion prevention plan must be in place for storage.
- Ensure the storage location is well ventilated.
- Keep away from ignition sources (avoid exposure to heat and smoking).
- Temperature range for storage:  $-25\text{ }^{\circ}\text{C}$  to  $70\text{ }^{\circ}\text{C}$
- Only store the outdoor unit in its exfactory protective packaging.
- Protect the outdoor unit against damage.
- The maximum number of outdoor units that may be stored in one place is determined according to local conditions.
- The appliance shall be stored in a room without continuously operating ignition sources (for example: open flames, an operating gas appliance or an operating electric heater).

#### CAUTION

A fire with R454C should only be fought with  $\text{CO}_2$  or dry powder extinguishers.

## About the refrigerant

### WARNING

- The following applies to R454C refrigerant systems.
- Prior to work on systems containing flammable refrigerants, safety checks are necessary to minimize the risk of ignition.

For repair of the refrigerating system, the following precautions should be complied with prior to conducting work on the system.

Work should be undertaken under a controlled procedure so as to minimize the risk of a flammable gas or vapor being present while the work is being performed.

All maintenance staff and others working in the local area should be instructed on the nature of work being carried out. Work in confined spaces should be avoided. The area around the workspace should be sectioned off. Ensure that the area is safe through control of flammable materials.

The area should be checked with an appropriate refrigerant detector prior to and during work, to ensure the technician is aware of potentially flammable atmospheres.

Ensure that the leak detection equipment being used is suitable for use with flammable refrigerants, i.e. , the equipment should be non-sparking, adequately sealed or intrinsically safe. If any hot work is to be conducted on the refrigeration equipment or any associated parts, appropriate fire extinguishing equipment should be available to hand. Have a dry powder or CO<sub>2</sub> fire extinguisher adjacent to the charging area.

No person carrying out work in relation to a refrigeration system which may expose any pipe that contains or has contained flammable refrigerant should use any sources of ignition in such a manner that it may lead to the risk of fires or explosions.

Prior to work taking place, the area around the equipment should be checked to make sure that there are no flammable hazards or ignition risks.

Ensure that the area is in the open or adequately ventilated before breaking into the system or conducting any hot work. A degree of ventilation should continue during the work. The ventilation should safely disperse any released refrigerant and preferably expel it externally into the atmosphere.

Where electrical components are being changed, they shall be fit for the purpose and to the correct specification.

At all times the manufacturer's maintenance and service guidelines shall be followed. In case of any doubt, consult the manufacturer's technical department for assistance.

The following checks should be applied to installations using flammable refrigerants:

- The charge size should depend on the size of the room within which refrigerant containing components are installed;
- The ventilation machinery and outlets should operate adequately and not be obstructed;
- If an indirect refrigerating circuit is used, the secondary circuit should be checked for any refrigerant;
- Marking to the equipment continues to be visible and legible. Markings and signs that are illegible shall be corrected;
- Refrigerating pipe or components are installed in a position where they are unlikely to be exposed to any substance which can corrode refrigerant containing components, unless the components are constructed of materials which are inherently resistant to being corroded or are suitably protected against being so corroded;.

Repair and maintenance of electrical components should include initial safety checks and component inspection procedures.

If a fault exists that could compromise safety, then no electrical supply shall be connected to the circuit until it is satisfactorily dealt with. If the fault cannot be corrected immediately but it is necessary to continue operation, an adequate temporary solution shall be used. This shall be reported to the owner of the equipment so all parties are advised.

Initial safety checks shall include:

- That capacitors are discharged: this shall be done in a safe manner to avoid possibility of sparking;
- That no live electrical components and wiring are exposed while charging, recovering or purging the system;
- That there is continuity of earth bonding.
- Sealed electrical components shall not be repaired.

During repairs of sealed components, all power supplies should be disconnected from the equipment where work is in progress prior to any removal of sealed covers or other components. If it is absolutely necessary to keep a power supply connected with the equipment during servicing, a permanent leak detection should be performed at the most critical point to avoid a potential hazard.

Particular attention should be paid to the following to ensure that the casing is not altered in such a way that the level of protection is affected by working on electrical components. This includes damage to cables, an excessive number of connections, terminals not compliance with original specifications, damage to seals, and incorrect fitting of glands.

Ensure that seals or sealing materials have not degraded in such a manner that they no longer serve for the purpose of preventing the ingress of flammable atmospheres. Parts for replacement should be in accordance with the manufacturer's specifications.

Do not apply any permanent inductive or capacitance loads that exceed the permissible voltage or current of the equipment in use to the circuit.

Intrinsically safe components are the only types that can be worked on while live in the presence of a flammable atmosphere. The test apparatus should be provided with the correct rating.

Replace components only with parts specified by the manufacturer. Other parts may result in the ignition of refrigerant in the atmosphere due to a leak.

Check and ensure that cabling is free from wear, corrosion, excessive pressure, vibration, sharp edges or any other adverse environmental effects. The check should also take into account the effects of ageing or continual vibration from sources such as compressors or fans.

When breaking into the refrigerant circuit to make repairs - or for any other purpose - conventional procedures shall be used. However, for flammable refrigerant it is important that best practice is followed since flammability is a consideration. The following procedure shall be adhered to:

- Remove refrigerant;
- Purge the circuit with inert gas (optional for A2L);
- Evacuate (optional for A2L);
- Purge with inert gas (optional for A2L);
- Open the circuit by cutting or brazing.

The refrigerant should be recovered into correct recovery cylinders. The system should be "flushed" with OFN to guarantee the unit safety. This process may need to be repeated several times. Compressed air or oxygen should not be used for this task.

Flushing should be achieved by breaking the vacuum in the system with OFN and continuing to fill until the working pressure is achieved before venting to the atmosphere and pulling down to a vacuum. This process should be repeated until no refrigerant exists in the system. When the final OFN charge is used, the system should be vented down to the atmospheric pressure so that the work can start.

This operation is absolutely vital if brazing operations on the pipe-work are to take place.

Ensure that the outlet for the vacuum pump is not close to any ignition sources and adequate ventilation is available.

Ensure that contamination of different refrigerants does not occur when using charging equipment. Hoses or lines should be as short as possible to minimize the amount of refrigerant contained in them. Prior to recharging the system, it should be pressure tested with OFN.

Before carrying out this procedure, it is essential that the technician is completely familiar with the equipment and all its detail. It is recommended good practice that all refrigerants are recovered safely.

Prior to the task being carried out, an oil and refrigerant sample shall be taken in case analysis is required prior to re-use of recovered refrigerant. It is essential that electrical power is available before the task is commenced.

- a) Become familiar with the equipment and its operation.
- b) Isolate the system electrically.
- c) Before attempting the procedure, ensure that:
  - Mechanical handling equipment is available, if required, for handling refrigerant cylinders;
  - All personal protective equipment is available and being used correctly;
  - The recovery process is supervised at all times by a competent person;
  - The recovery equipment and cylinders should conform to the appropriate standards.
- d) Pump down refrigerant system, if possible.

- e) If a vacuum is not possible, make a manifold so that refrigerant can be removed from various parts of the system.
- f) Make sure that the cylinders are situated on the scales before recovery.
- g) Start the recovery machine and operate it in accordance with manufacturer's instructions.
- h) Do not overfill the cylinders. (No more than 80 % of volume for liquid charge).
- i) Do not exceed the maximum working pressure of the cylinders, even temporarily.
- j) When the cylinders have been filled correctly, make sure that the cylinders and the equipment are removed from the site promptly and all isolation valves on the equipment are closed off.
- k) Recovered refrigerant should not be charged into another refrigeration system unless it has been cleaned and checked.

Equipment should be labeled stating that it has been de-commissioned and emptied of refrigerant. The label should be dated and signed. Ensure that the equipment is provided with a label stating the existence of flammable refrigerant in the equipment.

When removing refrigerant from a system, either for servicing or decommissioning, it is recommended that all refrigerants be removed safely. Always transfer refrigerant into appropriate cylinders. Ensure that a correct number of cylinders are available for supporting the total system charge. All cylinders to be used should be designated for the recovered refrigerant and labeled for that refrigerant (i.e. special cylinders for the recovery of refrigerant). The cylinders should be complete with pressure relief valves and associated shut-off valves in good working conditions. Empty recovery cylinders should be evacuated and, if possible, cooled down before recovery occurs.

The recovery equipment should be in good working conditions with a set of instructions concerning the equipment that is at hand and should be suitable for the recovery of flammable refrigerants. In addition, a set of calibrated weighing scales should be available and work properly. Hoses should be complete with leak-free disconnect couplings and work properly.

Before using the recovery machine, check and ensure that it is in satisfactory working conditions and has been properly maintained, and that all associated electrical components are sealed to prevent ignition in the event of a refrigerant leak. Consult the manufacturer if in in case of any doubt.

The recovered refrigerant should be returned to the refrigerant supplier in correct recovery cylinders, with the relevant Waste Transfer Note arranged. Do not mix refrigerants in recovery units and especially not in cylinders. If any compressor or compressor oils is to be removed, ensure that it has been evacuated to an acceptable level to ensure that flammable refrigerant does not remain within the lubricant. The evacuation process should be carried out prior to returning the compressor to the supplier. To accelerate this process, you can only heat the compressor body with an electric heater. Draining oil from the system should ensure the safety.

Warning: Disconnect the appliance from its power source during servicing and parts replacement.

These units are partial unit air conditioners, complying with partial unit requirements of this International Standard, and must only be connected to other units that have been confirmed as complying to corresponding partial unit requirements of this International Standard.

## Leak detection

Under no circumstances shall potential sources of ignition be used in the searching for or detection of refrigerant leaks. A halide torch (or any other detector using a naked flame) shall not be used.

The following leak detection methods are deemed acceptable for systems containing flammable refrigerants.

Electronic leak detectors should be used to detect flammable refrigerants, but the sensitivity may not be adequate, or may need re-calibration. (Detection equipment should be calibrated in a refrigerant-free area.) Ensure that the detector is not a potential source of ignition and is suitable for the refrigerant. Leak detection equipment should be set at a percentage of the LFL of the refrigerant and should be calibrated to be suitable for the refrigerant employed, with the appropriate percentage of gas (25% maximum) confirmed. Leak detection fluids should be suitable for most refrigerants but the use of detergents containing chlorine should be avoided as the chlorine may react with the refrigerant and corrode the copper pipes. If a leak is suspected, all naked flames should be removed or extinguished.

If a leakage of refrigerant is found and brazing is required, all of the refrigerant should be recovered from the system, or isolated (by means of shut off valves) in a part of the system that is far from the leak. The system should be purged with oxygen free nitrogen (OFN) both before and during the brazing process.

NOTE Examples of leak detection methods are:

- Bubble method.
- Fluorescent agent method.

Removal of refrigerant shall be according to IEC60335-2-40 Clause DD.8.

## Disposal

This equipment uses flammable refrigerants. The disposal of the equipment must comply with national regulations.

Do not dispose this product as unsorted municipal waste. Collection of such waste separately for special treatment is necessary.

- Do not dispose of electrical appliances as unsorted municipal waste, and use separate collection facilities.
- Contact your local government for information regarding the collection systems available.

If electrical appliances are disposed of in landfills or dumps, hazardous substances can leak into the groundwater and get into the food chain, damaging your health and well-being.

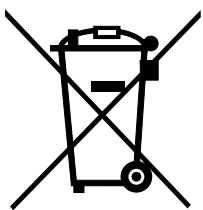

**WARNING: RISK OF FIRE**

## 2 GENERAL INTRODUCTION

### 2.1 Outdoor unit

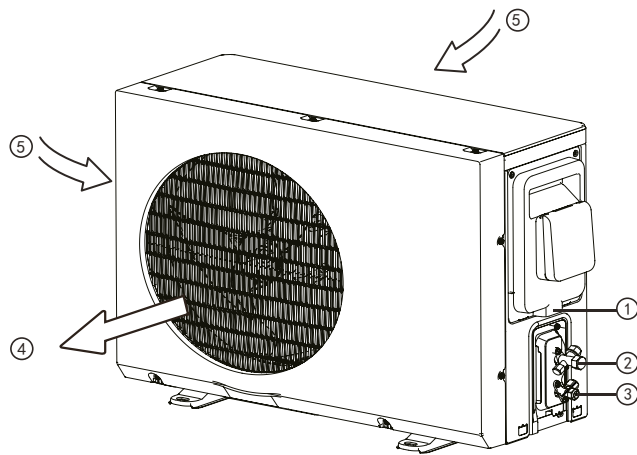

Fig. 2-1

Table 2-1

No.	Name
①	Power cord enter
②	Refrigerant gas valve
③	Refrigerant liquid valve
④	Air outlet
⑤	Air inlet

### 2.2 Water tank

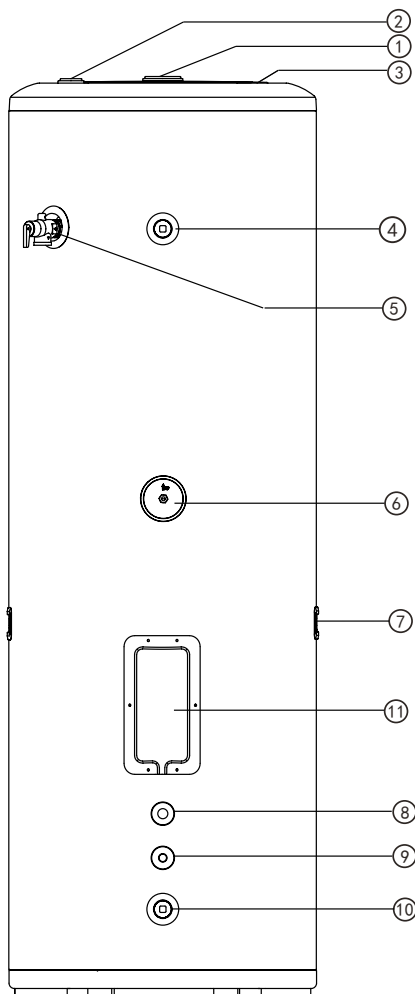

Fig. 2-2

Table 2-2

No.	Name
①	Magnesium rod insertion port
②	Foam filling port
③	Reserved port
④	Water outlet
⑤	Pressure temperature relief valve
⑥	Water tank temperature sensor
⑦	Handle
⑧	Refrigerant gas pipe
⑨	Refrigerant liquid pipe
⑩	Water inlet/Drain outlet
⑪	Electric auxiliary heater

## 2.3 Specifications

Table 2-3

	Outdoor unit model		MUACSB-200/300-H16-E			
	Water tank model		MUACSB-200-H16-I	MUACSB-300-H16-I		
General	Ambient temperature		°C	-15°C to 46 °C		
	Leaving water temperature		°C	38°C to 70°C (default 54 °C)		
	Heating	Capacity <sup>(1)</sup>	W	1800		
		Max Input (HP+E-Heater)	W	1050+2100		
	Hot water yield		m³/h	0.0443 / 0.0443		
	Refrigerant piping	Liquid side	mm / inch	φ 6.35 / φ 1/4"		
		Gas side	mm / inch	φ 9.52 / φ 3/8"		
		Max. height difference	m	20		
		Max.refrigerant pipe length	m	30		
	Design pressure		MPa	3.3		
Outdoor unit	Outdoor unit power supply		V/N/Hz	220-240/1/50		
	Max. current		A	4.6+9.1	4.6+9.1	
	Compressor Type		Type	DC inverter rotary		
	Fan		Type	DC inverter		
	Air side heat exchanger		Type	Hydraulic aluminum fin + Inner grooved coppertube		
	Throttle		Type	Electric expansion valve		
	Outdoor sound pressure level		dB(A)	60		
	Dimension	Unit dimension (L x W x H)		mm	804 x 327 x 555	
		Packing dimension (L x W x H)		mm	845 x 390 x 630	
		Net weight		kg	27	
Refrigerant	Type		R454C			
	Charged weight		g	900		
Water tank	Tank volume		L	190	280	
	Electric heater	Capacity	kW	2.1	2.1	
		Power supply	V/N/Hz	220-240/1/50	220-240/1/50	
	Dimension	Unit dimension (W x D x H)		mm	505 x 505 x 1665	580 x 580 x 1735
		Packing dimension (W x D x H)		mm	600 x 595 x 1770	690 x 675 x 1835
Net weight		kg	77.5	99		
EN16147 <sup>(2)</sup>	Load profiles		/	L	XL	
	Water Heating energy efficiency		/	124.4%	144.6%	
	COP		/	2.98	3.49	
	Energy efficiency class		/	A+	A+	
	V40		L	256	365	
	θ'WH		°C	53.5	53.9	
	AEC		kWh	823	1159	
NF	Category		/	★★★		

Notes:

(1) Test condition: 7 °C / 6 °C, start water temperature is 10 °C, termination temperature 45 °C.

(2) Test condition: Average climate (7 °C / 6 °C), set temperature 54 °C.

Fig. 2-3

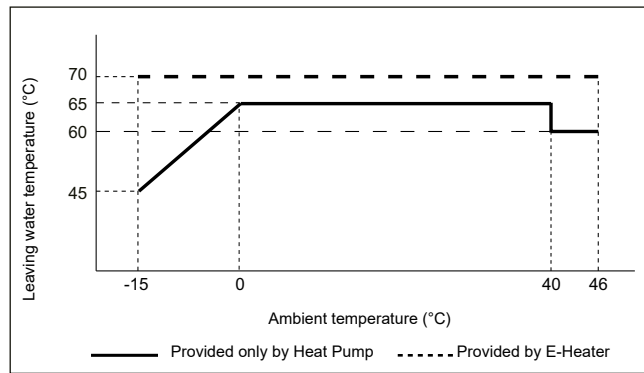

### 3 BEFORE INSTALLATION

#### 3.1 Accessories

Table 3-1

	ACCESSORY NAME	QTY.	SHAPE	PURPOSE
Outdoor unit	Installation manual	1		Outdoor unit and water tank instruction
	Drain pipe joint	1		For condensate water draining
	Water drainage pipe	1	—	Condensate water drainage of unit bottom plate
	Seal ring	1		Seal between water drainage connection and external machine
	Polypropylene strap	1	—	Wrap the refrigerant tube between outdoor unit and water tank
	Magnetic ring	1		Installed on the temperature sensor wire and extended line body
	Wire controller	1		Wire controller and installation accessories (backboard and screws)
	Wire controller extension cable	1		Extension cable connecting the line controller and outdoor unit
Water tank	Water tank fixing strip	1		Fixed water tank
	Connector	2		Connect water tank and safe care
	Seal ring	2		Prevent rust between water tank and joint
	Flare nut	2		For connecting the refrigerant copper pipe to the water tank and outdoor unit

#### 3.2 Space

#### NOTE

During installing, it is necessary to reserve enough installation space and maintenance space according to the following figures.

Do not install the outdoor unit and tank in a enclosed space.

3.2.1 Outdoor unit installation and maintenance space, see Fig 3-1 and Fig 3-2 . (Unit: mm)

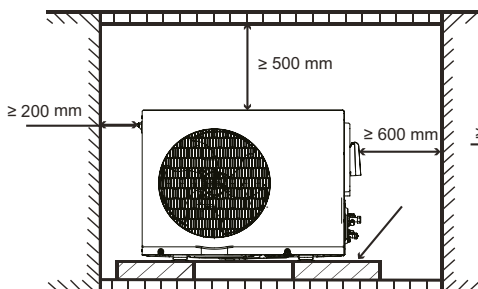

Fig. 3-1

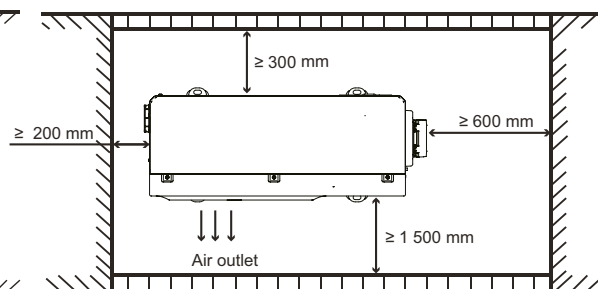

Fig. 3-2

3.2.2 Water tank installation and maintenance space, see Fig 3-3, Fig 3-4 . (Unit: mm)

**NOTE**

- If the water tank is completely installed outdoors, it is strongly recommended to install a rain shelter.
- When the water tank is installed outdoors, the distance between the water tank and the fence is not less than 200 mm.
- For the water tank with electric auxiliary heater, the electric auxiliary heater shall be at least 1000 mm away from the wall to ensure that there is enough space for electric auxiliary heat maintenance.

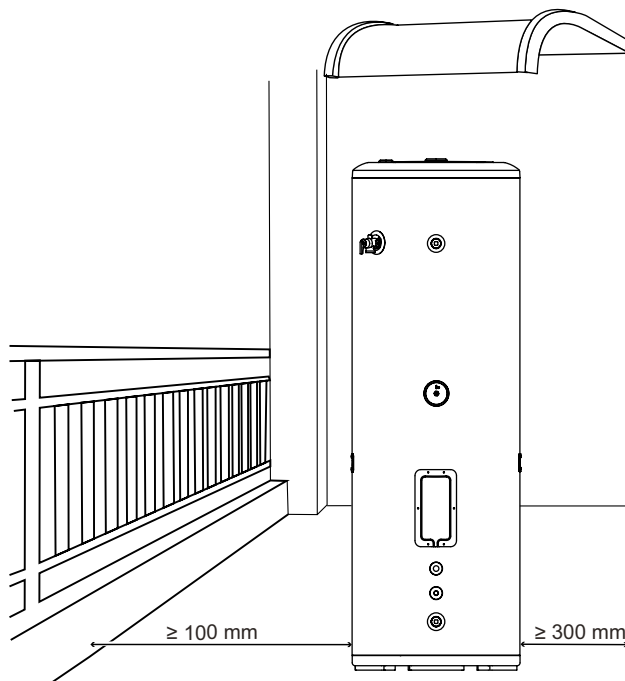
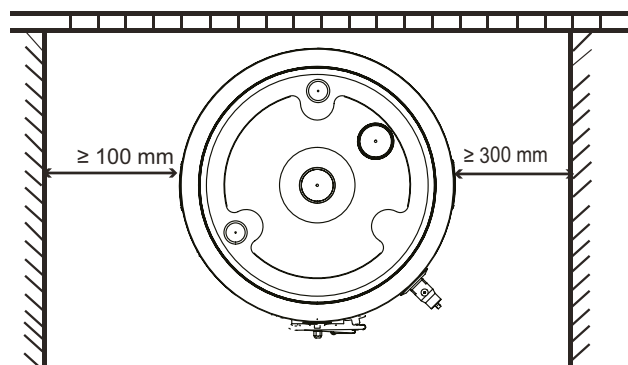

Fig. 3-3



The Aux\* is replaceable material, need to make sure there is enough space for e-heater maintenance.

Fig. 3-4

\* Electric auxiliary heater is shortened to Aux.

## 4 INSTALLATION

### NOTE

- Ask your dealer or specialized person for moving, repair, and maintenance.
- Install it in the place without direct sunlight and other direct heat radiations. If it can't be avoided, please add a cover to prevent unit from direct sunlight.
- The ceiling is horizontal, and its structure can endure the weight of the water tank.
- Please firmly install the unit, otherwise it may cause abnormal noise and vibration.
- Remove obstacles nearby, a narrow circulation space may influence performance of the unit.
- Install in the place that closes to water tank as far as possible, under the condition that the installation requirements could be satisfied.
- When installing in the place that near to the sea and high place where strong wind blows, install the unit against a wall or use a baffle when necessary to ensure the unit could run normally, see Fig 4-1. Especially in the place with strong wind, pay attention not to let strong wind blow back to the unit.
- If install the unit in a basement, inside the room or other confined space, please pay attention to air discharge and air supply circulation around the unit and outside. Circulation air volume should not less than 1250 m<sup>3</sup>/h.

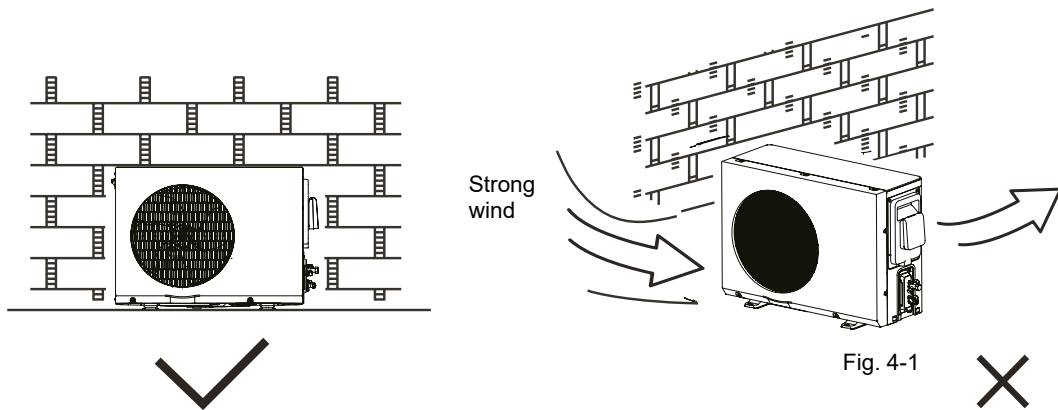

Fig. 4-1

### 4.1 Dimension and mounting

4.1.1 Outdoor unit, see Fig. 4-2, Fig. 4-3 and Table 4-1. (Unit: mm)

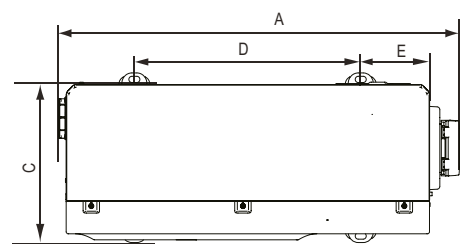
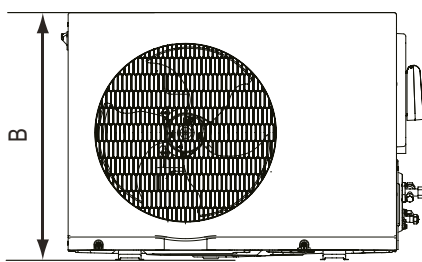

Fig. 4-2

Please fix the four bases of the outdoor unit on the flat ground with bolts.

Table 4-1

Dimension and mounting dimension				
A	B	C	D	E
804	555	302	452	137

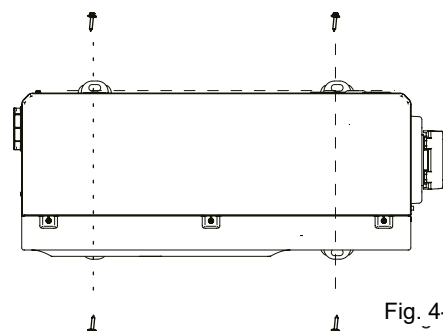

Fig. 4-3

4.1.2 Water tank, see Fig. 4-4, Fig. 4-5 and Table 4-2. (Unit: mm)

Table 4-2

Dimension Model	A	H
200 L	505	1665
300 L	580	1735

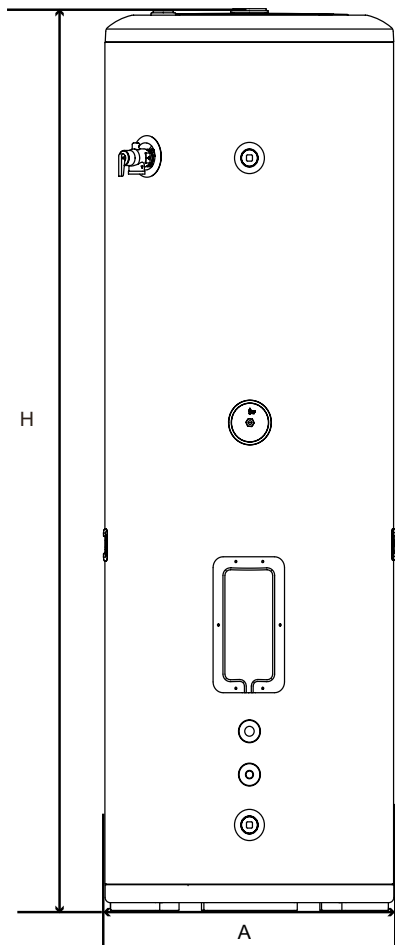
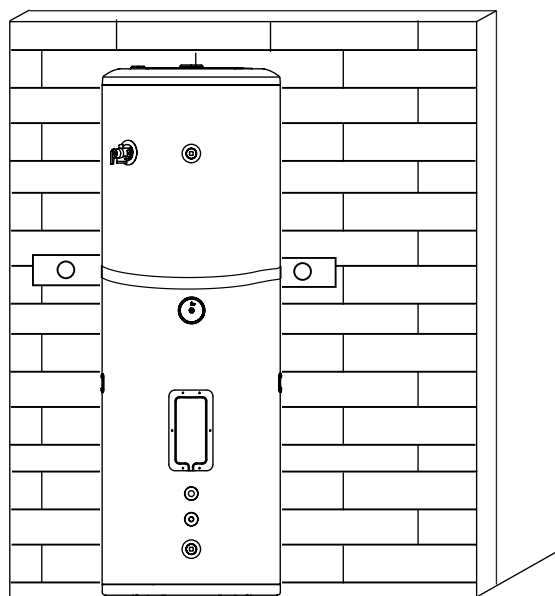

Fig. 4-4



Please install the water tank fixing strip as shown in the figure to ensure that the water tank is stably fixed.

Fig. 4-5

4.2 Drain hole position

Water outlet connection pipe/ Gasket

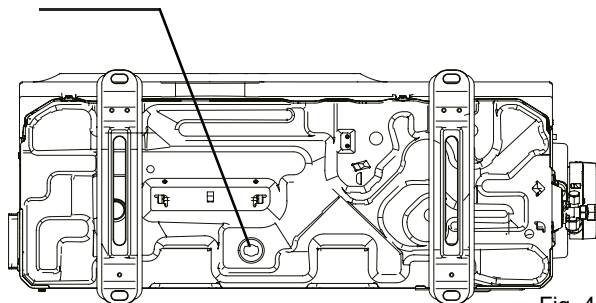

Fig. 4-6

Please use the Allen wrench to open the drain valve to drain the water. If no water flows out, it means that the draining is completed.

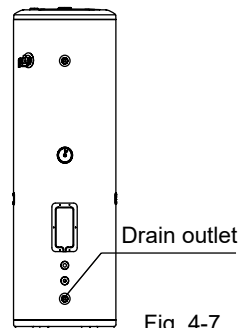

Fig. 4-7

## 4.3 Pipe connection

### 4.3.1 Unit connection sketch

Unit connection sketch, please refer to Fig.4-8.

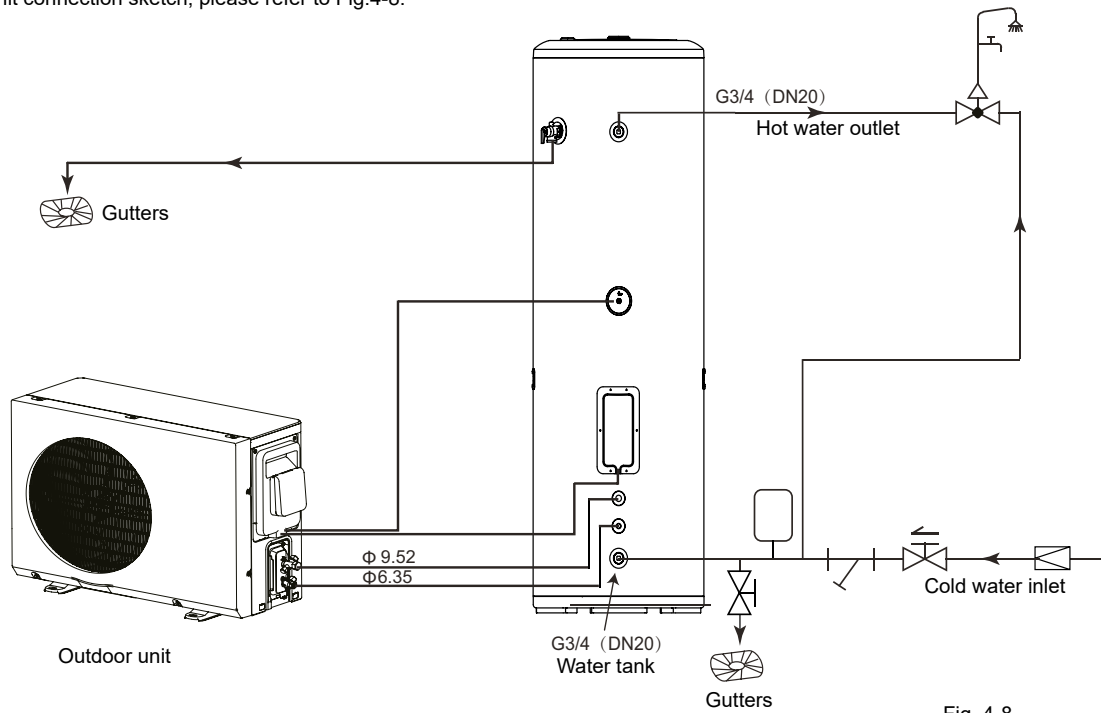

Fig. 4-8

Fig. 4-3

Icons and meanings

Name	Water use site	One-way stop valve (field supply)	Water mixing valve (field supply)	Shut valve (field supply)
Icon				
Name	Gutter	Expansion tank (field supply, suggest to install)	Y-type filter (≥40 meshes) (field supply)	Pressure reducing valve (field supply)
Icon				

### NOTE

- The water tank temperature can be set from 38 °C to 70 °C.
- The minimum water inlet pressure is not less than 0.15 MPa, and the maximum is not more than 0.5 MPa.
- If the inlet water pressure is less than 0.15 MPa, a pump should be installed at the water inlet.
- To guarantee the safety usage of tank, a pressure reducing valve should be installed in the water inlet pipe, if the water pressure exceeds 0.5 MPa.
- It is strongly recommended to use thread seal tape for sealing when connecting water pipes and valves.
- If the water temperature at the outlet of mixing valve is higher than usage, please install a mixing valve at the end user.
- To avoid backflow and prevent non-drinking water from entering the water mains, a non return valve should be installed at the inlet of the waterway.
- Mechanical connectors used indoors shall comply with ISO 14903. When mechanical connectors are reused indoors, sealing parts shall be renewed. When flared joints are reused indoors, the flare part shall be re-fabricated. Refrigerant tubing shall be protected or enclosed to avoid damage.

#### 4.3.2 PTR valve

- The valve body unloading pressure is 850 kPa, unloading temperature is 99 °C, and the valve body opening energy valve is 46 kW. PTR valve is tightened with a 68 N.m torque wrench. Apply sealant to the first 3 turns of screw thread before installation;
- After installation, the outlet of the drain pipe shall be installed face down, and the thread turns that are not screwed into the PTR valve shall be less than 3 turns.
- Before filling the water tank, the PTR valve must be installed properly.

### CAUTION

Do not quickly operate the handle of valve, to avoid water hammer impact and damage to the valve.

- The PTR valve should be checked every half year to make sure that there is no restriction of the valve. Please beware of hot water from the valve. The drainage pipe should be well insulated in order to prevent water inside pipe from freezing in cold weather.

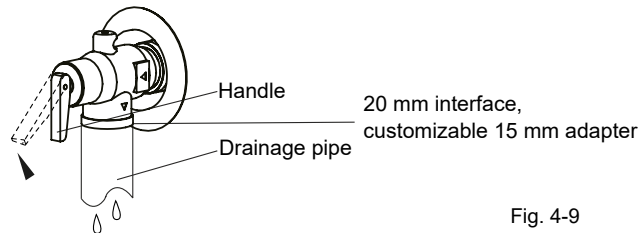

Fig. 4-9

#### 4.3.3 Stop valve instruction

- In general, the shape of stop valve and names of each part are shown in Fig.4-10.
- Effect of stop valve:
  - Stop the system when the unit is working.
  - When water tank connects with the outdoor unit, vacuumize and add refrigerant through it.
  - Stop the system and then recycle refrigerant to outdoor unit when maintaining.
- Open and close the stop valve:
  - Open: dismantle the bonnet by wrench and insert an \*Allen key to spool, open the stop block anticlockwise and then tighten the bonnet.
  - Close: use a wrench to dismantle the bonnet and insert an Allen key to spool, close the stop block clockwise and then tighten the bonnet.

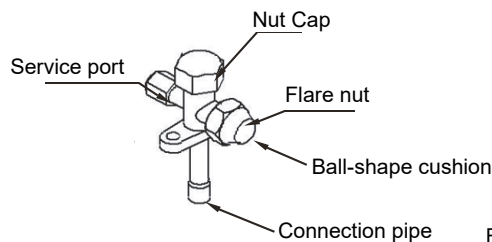
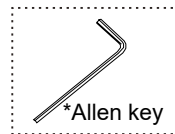

Fig. 4-10

### CAUTION

Before water heater runs, please make sure every stop valve has been opened.  
 When operating the valves, make sure that there are no open flames or sparks to prevent explosion or ignition.  
 A brazed, welded, or mechanical connection shall be made before opening the valves to permit refrigerant to flow between the refrigerating system parts

#### 4.3.4 Connection length of outdoor unit and water tank pipe and height difference requirements:

Table 4-4

Max. length (m)	Max. height difference (m)	Standard length (m)	Standard height difference (m)
30	20	3	0

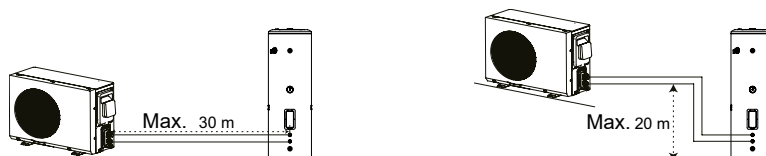

## NOTE

- Do not let air, dust, or other impurities fall in the pipe system during installation.
- The connecting pipe should not be installed until the water tank and outdoor units have been fixed already.
- Keep the connecting pipe dry, and do not let moisture in during installation.
- When connecting copper pipe, please wrap it with thermal insulation material.

### 4.4 Wire Controller Installation

#### 4.4.1 Installation on the outdoor unit

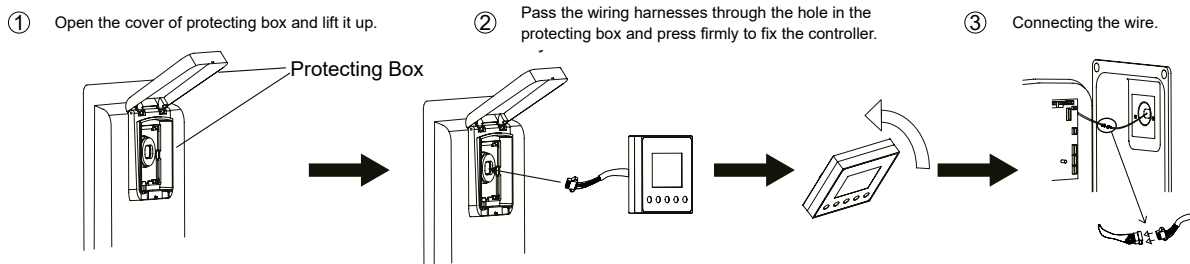

#### 4.4.2 Installation indoor side

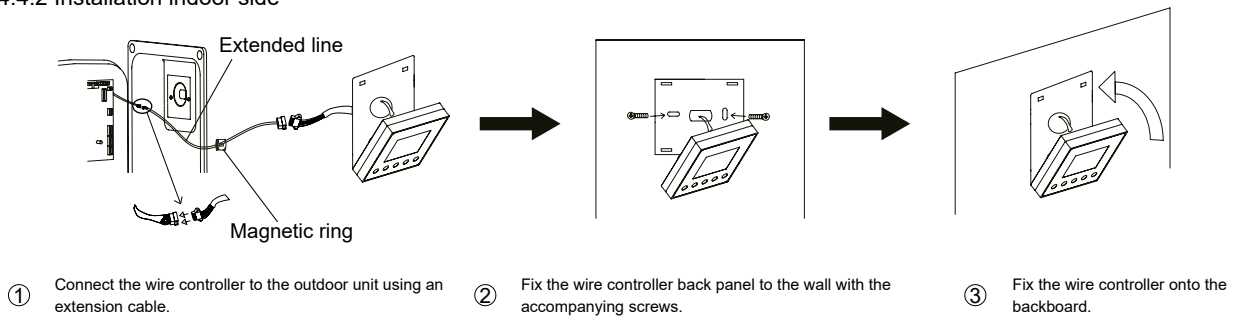

### 4.5 Vacuum Drying

#### 4.5.1 Purpose

Vacuum drying should be performed in order to remove moisture and non-condensable gases from the system. Removing moisture prevents ice formation and oxidization of copper piping or other internal components. The presence of ice particles in the system would cause abnormal operation, whilst particles of oxidized copper can cause compressor damage. The presence of non-condensable gases in the system would lead to pressure fluctuations and poor heat exchange performance.

#### 4.5.2 Procedure

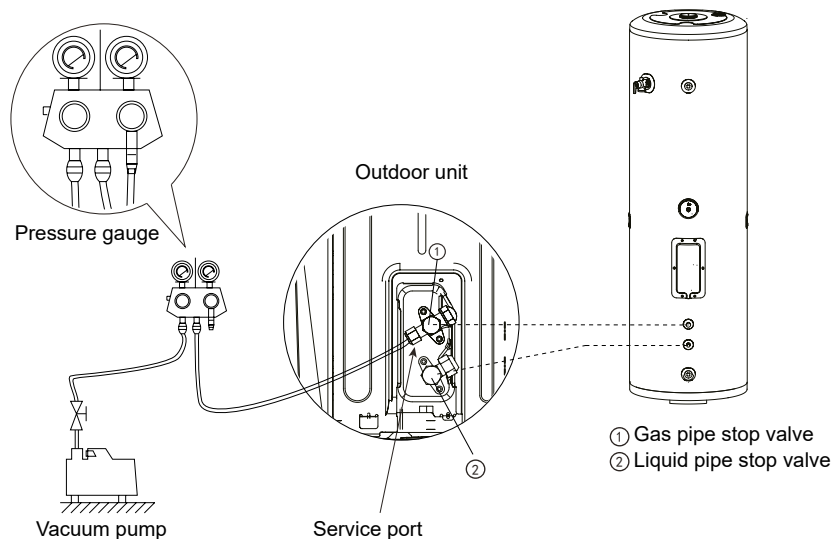
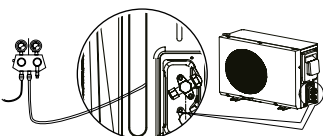
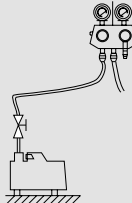
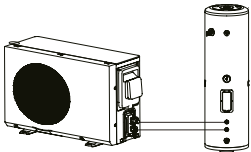
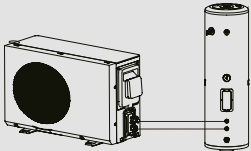

Fig. 4-11

Table 4-5

ITEM	DESCRIPTION	IMAGE	NOTICE
1	Connect the (low pressure side) hose of a pressure gauge to the outdoor unit gas pipe stop valve.		Before performing vacuum drying, make sure that all the outdoor unit stop valves are firmly closed.
2	Connect the hose to the vacuum pump.		<p>1. Mixing of pump lubricant with compressor oil could cause compressor malfunction and a one-way valve should therefore be used to prevent vacuum pump lubricant seeping into the piping system.</p> <p>2. Using a vacuum pump with a discharge in excess of 4 L/s and a precision level of 0.02 mmHg is recommended.</p>
3	Connect the outdoor unit gas pipe stop valve to water tank gas pipe.		
4	Connect the outdoor unit liquid pipe stop valve to water tank liquid pipe.		
5	Start the vacuum pump and then open the pressure gauge valves to start vacuum the system.		
6	After 15-20 minutes, close the pressure gauge valves.		
7	After a further 5 to 10 minutes check the pressure gauge. If the gauge has returned to zero, check for leakages in the refrigerant piping. If the gauge is no change, then vacuum drying is OK.		
8	Re-open the pressure gauge valves and continue vacuum drying for at least 20 minutes and until a pressure difference of 756 mmHg or more has been achieved. Once the pressure difference of at least 756 mmHg has been achieved, continue vacuum drying for 20 minutes.		
9	Close the pressure gauge valves and then stop the vacuum pump.		
10	After 1 hour, check the pressure gauge. If the pressure in the piping has not increased, the procedure is finished. If the pressure has increased, check for leakages.		After vacuum drying, keep the hoses connected to the pressure gauge and to the outdoor unit stop valves, in preparation for refrigerant charging.

## 4.6 Refrigerant charge

- If the pipe length is less than 10 m, there is no need to add additional refrigerant charge.
- If the pipe length is more than 10 m, adding additional refrigerant charge is necessary, and the rule is 20 g/m for the additional pipe more than 10 m. For example, installing a pipeline length of 15 m (one-way liquid pipe length) and adding a refrigerant volume of  $20 \times (15-10) = 100$  g.

## 5 ELECTRICAL CONNECTION

### ⚠ CAUTION

- The heat pump should use separate power supply with rated voltage. If voltage is not stable, please use stabilized voltage supply.
- The external power supply to the heat pump should have ground wiring, which is linked to the ground wiring of the water tank and outdoor unit.
- The wiring work should be done by qualified persons according to circuit drawing.
- A leakage protector should be installed according to the National Standard concerning electrical appliance.
- An all-pole disconnection device which has at least 3 mm separation distance in contact points should be installed.
- Power supply cords and signal wires should be arranged properly. Separate strong current wire and weak current wire, meanwhile they can't constant with connection pipe and valve.
- Power supply with a leakage protector should be installed in a water-proof place inside the room.
- Don't do cross connection between 2 wires and signal wires must be shielded.
- When power supply cord parallels with controlling wire, please put the wires to corresponding wire pipe and leave proper space between wires.
- Supply cords for indoor appliances shall be at least those of ordinary tough rubber sheathed cords (code designation 60227 IEC 53), supply cords for outdoor appliances shall be at least those of ordinary polychloroprene sheathed cords (code designation 60245 IEC 57).
- If the supply cord is damaged, it must be replaced by the manufacturer, its service agent or similarly qualified persons in order to avoid a hazard.
- Do not turn on the power until you have checked carefully after wiring.
- The appliance shall be installed in accordance with national wiring regulations.

### 5.1 Power supply cords

#### 5.1.1 Specification of power supply

Item Model	Power	Min. wire dia. (mm <sup>2</sup> ) (metal pipe synthetic resin pipe wire)		Manual switch (A)		Leakage protector	E-heater Power (W)
		Successive length ≤ 30 m	Ground wire	Capacity	Fuse		
200 L / 300 L	220-240 V~ 50 Hz	2.5	2.5	20	15	30 mA below 0.1 sec	2100

### ⚠ CAUTION

- Specifications of power wires above (outdoor unit power wire and power wire that connects with water tank): H07RN-F.
- Power supply provided individually (not use power supply device).
- Wire diameter shown in the table above and successive length is the situation than voltage drop is in the range of 2 %, when successive length is longer than the value shown in the table, please select wire diameter according to relative standards.

### 5.2 Water tank temperature sensor installation

Connect the water tank temperature sensor wire connector to the outdoor unit T5 connector.

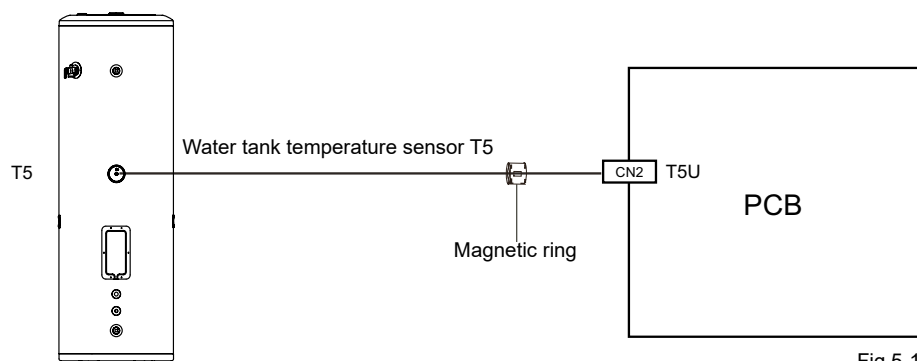

Fig.5-1

### 5.3 Outdoor unit & AUX. power connection

#### ⚠ CAUTION

If the water tank has the electric auxiliary heater (AUX.) function, please follow the steps below to connect the electric auxiliary heating power cord.

1. Remove the protective cover of the electric control box on the right side of the outdoor unit.

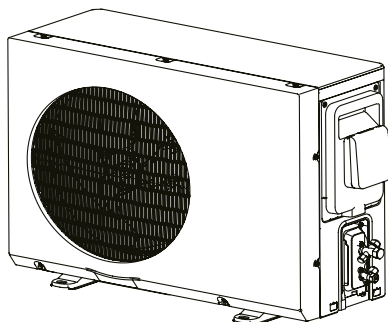

Fig.5-2

2. Connect the electric auxiliary heater power line on the water tank to the corresponding port on the terminal block.

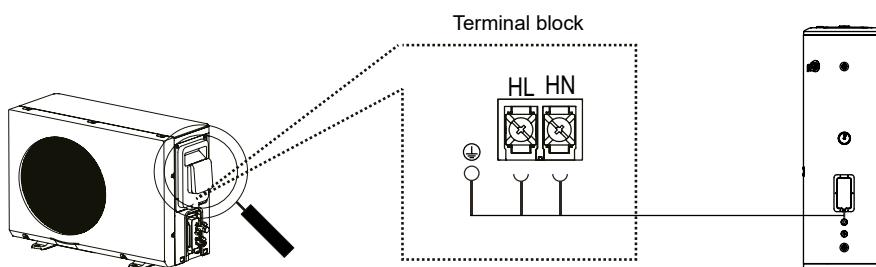

Fig.5-3

3. Power supply & Smart Grid & OPT function connection.

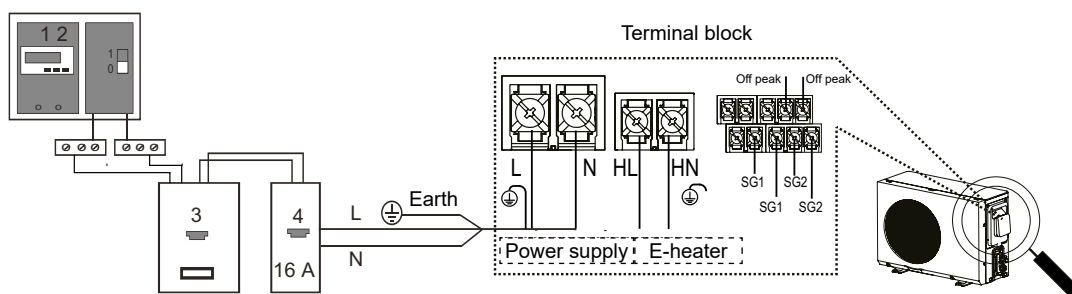

Fig.5-4

1. Electric counter
2. Global overcurrent and leakage circuit breaker
3. Electric leakage circuit breaker
4. Overcurrent circuit breaker

#### ⚠ CAUTION

- A leakage protector must be installed on power supply box outside the unit according to the figure above.
- Power supply with leakage protector must be installed inside or installed in the place that can satisfy water-proof requirements.
- This unit can be started only if it is grounded reliably.

## 5.4 Dip switch settings

### NOTE

The picture shown is for reference only, actual product may vary.





 means 0,  means 1.

Table 5-2

S1-1		1	Second setting parameters
		0	First setting parameters
S1-2		1	Reserve
		0	Reserve
S1-3		1	Reserve
		0	Reserve

## 6 OPERATION INSTRUCTIONS

### 6.1 Start up

1 After powered on, the display will light up.

When the wire controller is powered on for the second time, it needs to select the language (default English) and set the time & date. If there is no setting action after 20 seconds, it will exit the setting interface and set the language and time & date as default values. Later, you can set the language and time date in the General Setting.

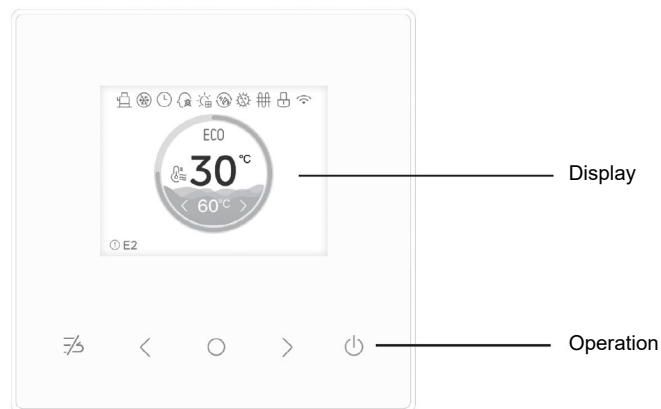

#### 2.1 Switch on/off

In the non-locked state, press the power button to switch between on and off states.

#### 2.2 Change setting temperature

In the non-locked state, Press < > to select the setting temperature (38-70 °C) source and start to heat water to set temperature.

#### 2.3 Change the mode

In the non-locked state, press the menu button to enter the menu options, select the mode menu, press the confirm button to enter mode selection, and use the left and right buttons to switch between ECO and BOOST modes.

ECO mode: The heat pump is activated first, and when the ambient temperature is below Td and the water temperature meets certain conditions, the electric auxiliary heating is activated. The priority of the heat pump is higher than that of the electric heating;

BOOST mode: Electric auxiliary heating and heat pump run together to heat up to the set temperature.

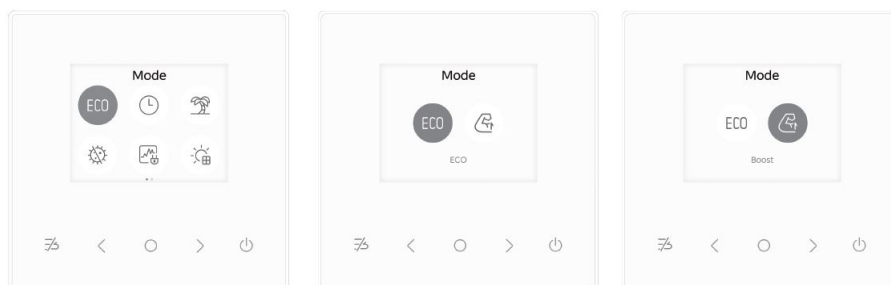

## 6.2 Wired controller operation

### 6.2.1 Display explanation

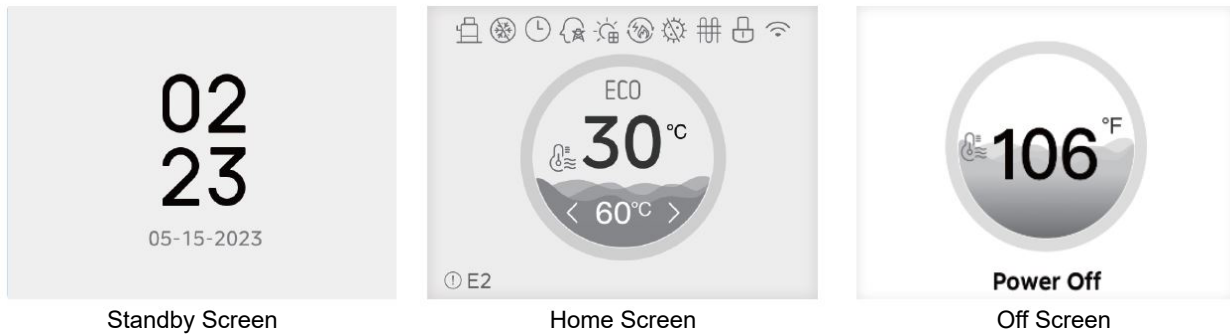

NO.	ICON	DESCRIPTION
1	02 23 05-15-2023	Current time and day
2	ECO	Operation Modes ECO, BOOST
3	30°C	Current Water Temperature
4	< 60°C >	Set Temperature, °C / °F
5	! E2	Error Code, displayed when a fault occurs, not displayed when no fault is present
6		Illuminates when the compressor is running
7		Illuminates when the anti-freeze function is active
8		Illuminates when the mute function is enabled
9		Illuminates when the defrost function is active
10		Illuminates when the daily timer function is active
11		Illuminates when the weekly timer function is active
12		Illuminates when the smart grid function is enabled
13		Illuminates when the solar function is enabled
14		Illuminates when the peak and off-peak electricity function is enabled
15		Illuminates when the gas hybrid function is enabled
16		Illuminates when the vacation mode is activated
17		Illuminates when the sterilization function is running
18		Illuminates when the electric heater is running
19		Illuminates when locked

## 6.2.2 Button explanation



ICON	DESCRIPTION
	Menu / Back Press in the main interface to enter the menu page; Press in a non-main interface to return to the previous page;
	Confirm / save / enter Confirm the setting and selection values
	On / Off
	Left and right: Change the status, change the selection
	Combination key "Lock/Unlock" Hold down for 2 seconds to lock or unlock the screen
	Combination key "Installation Settings" Press and hold for 3 seconds to enter the Installation Settings
	Press and hold for 3 seconds to enter the OTA upgrade interface

## 6.2.3 Functions explanation

### Operation and setting instructions

When setting related functions, use the left and right keys to select items, press the confirm key to set parameters, parameters will flash when they can be set, after adjusting parameters with the left and right keys, press the confirm key to confirm, press the "menu key" to return to the previous level page.

### 6.2.3.1 Schedule

#### • Daily Timing

Press the menu button on the main interface to enter the menu interface, select the schedule menu, and press the confirm button to enter. You can set 4 groups of daily timing (default is off).

The meaning of daily timing function: Set to execute a certain mode within a certain time period to reach a certain temperature value, and repeat the execution every day.

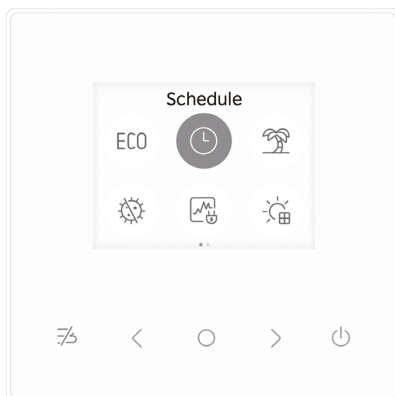

4 groups of timing default time:

Timing 1 (start time 08:00, end time 12:00), Timing 2 (start time 14:00, end time 18:00), Timing 3 (start time 20:00, end time 23:00), Timing 4 (start time 00:00, end

time 07:00), default operation mode ECO, set temperature 60 °C.

Press the left and right keys to select different timing periods, and press the confirm button to edit the time, mode, and temperature.

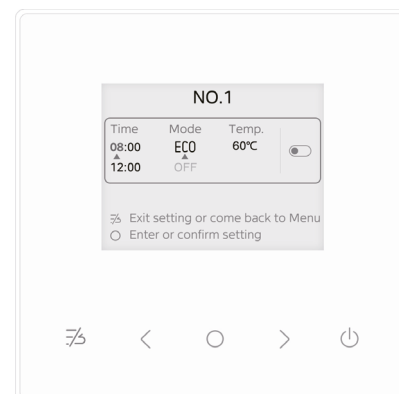

**Time Setting:** After selecting a specific time period, press the Confirm button to enter the time period setting. Move the cursor to select the start time or end time. The number will flash when selected. Use the left and right buttons to adjust the settings. The hour step is 1h, and the minute step is 10 minutes.

**Mode Setting:** Move the cursor to the mode, press the Confirm button, and the mode will flash. Use the left and right buttons to select ECO or BOOST.

Temperature Setting: Move the cursor to the temperature, press the Confirm button, and the temperature value will flash. Use the left and right buttons to set the target temperature.

Timer Validity Setting: Use the left and right buttons to move the cursor to the switch button, press the Confirm button to change the validity status of the timer period.

After the timer setting takes effect, the prompt is: The data has been saved.

- Weekly Timer

Set through the APP.

Note:

Daily timing and weekly timing cannot be effective simultaneously; weekly timing has a higher priority. When weekly timing is activated, daily timing automatically becomes ineffective.

When there is a conflict in the timing periods (overlapping start and end times), a message will indicate that it is ineffective.

When the unit is operating during the timing period, it can be turned off using the power button, and it will not operate according to the timing afterward.

When the unit is turned off outside the timing period, it can be turned on using the power button. After the unit stops, it will operate according to the timing settings.

### 6.2.3.2 Smart Grid

By selecting the Smart Grid option from the main menu and pressing the confirmation key, you can enter the function switch settings. After entering, clicking the “confirmation key” can turn off/on the Smart Grid function. When the Smart Grid function is enabled, the Smart Grid icon on the main interface will light up.

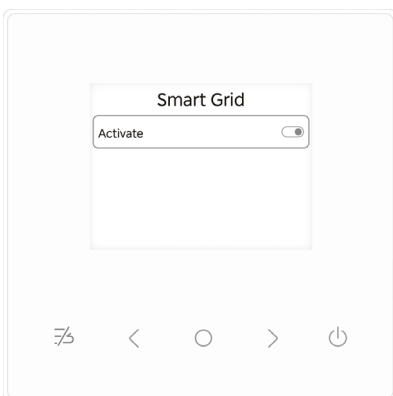
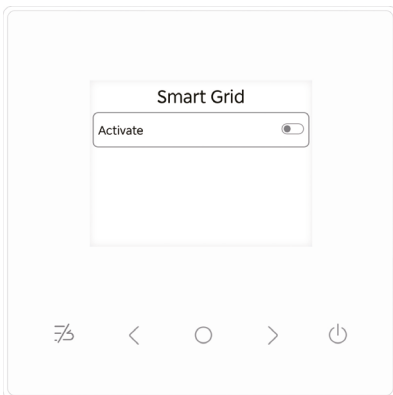

### 6.2.3.3 Holiday

By selecting the Holiday option through the main menu and pressing the confirmation key, you can enter the Holiday switch and Holiday start and end time settings.

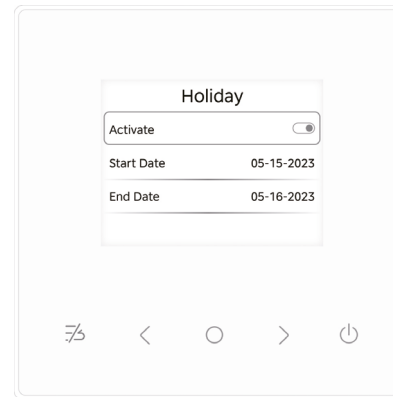
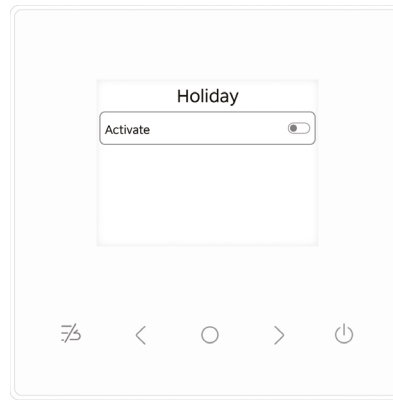

After entering the Holiday settings page, press the confirmation key to activate the Holiday function, and the start and end times of the Holiday will be displayed. Use the left and right keys to select the start and end times, and press the confirmation key to enter the time adjustment.

The default start time is the current time, and the end time is 7 days after the start time.

Note:

Before the end of the Holiday, pressing any key will prompt whether to exit the Holiday. Clicking YES will exit the Holiday.

### 6.2.3.4 Disinfection

By selecting the C option through the main menu and pressing the confirmation key, you can enter the disinfection function settings.

You can set the function on/off, Disinfection time, temperature, and Disinfection cycle time. Use the left and right keys to select the corresponding setting item, press the confirm key to set, use the left and right keys to adjust the setting value, and press the confirm key to confirm after setting.

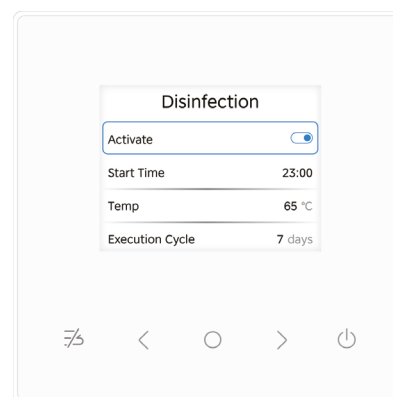

The Disinfection function is on by default, with a Disinfection time of 23:00, a Disinfection temperature of 70 °C, and a cycle of 7 days.

### 6.2.3.5 Hybrid

By selecting the Hybrid option through the main menu and pressing the confirm key, you can enter the Hybrid function switch settings.

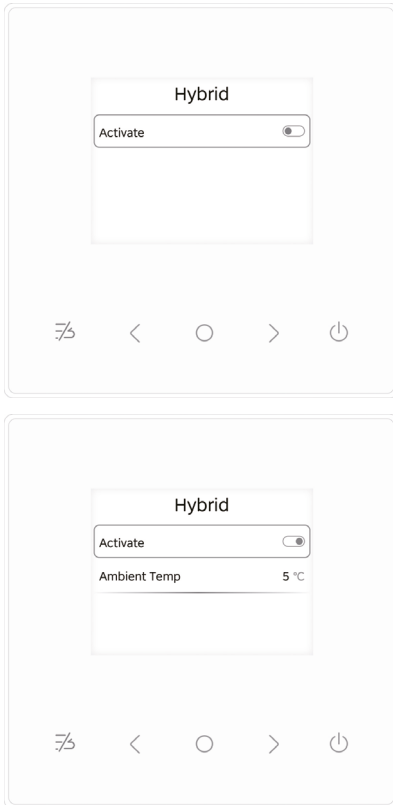

The Hybrid function is off by default. When users use an external heat source (usually gas) instead of the unit's electric auxiliary heat, they can use the unit's electric auxiliary heat port (HL/HN) to connect to the power supply of the external heat source, you can manually turn on this function. After turning it on, you can set the minimum operating ambient temperature for the heat pump (default 5 °C).

Note: If there is no external heat source, do not turn on this function, otherwise it may cause damage to the unit or insufficient hot water.

### 6.2.3.6 OPT. Backup

Press the confirm key through the main menu to select the OPT. Backup option, which allows you to enter the OPT. Backup function switch settings.

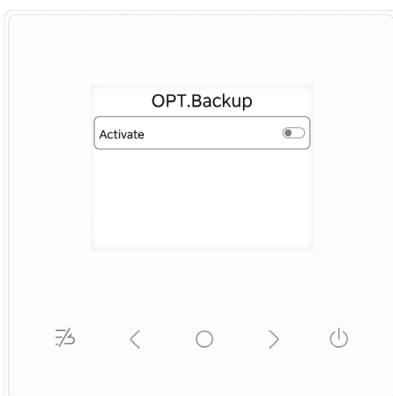

OPT. Backup is default off. After entering the function interface, you can turn the function on/off. Users can activate this function after connecting the off-peak signal to the outdoor unit, and the system will adjust its operation status based on the off-peak signal.

### 6.2.3.7 Consumption

On the menu page, select the energy analysis (power consumption) function icon, press the confirm key to enter the energy analysis function, where you can view power consumption statistics, categorized power consumption statistics, and historical data.

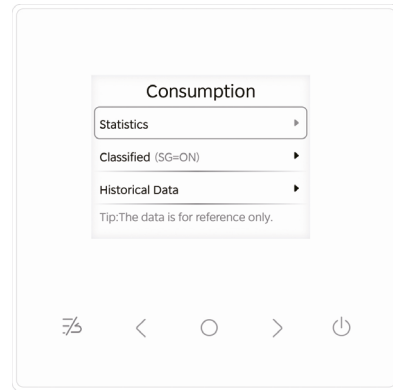

- Energy Analysis Home Page

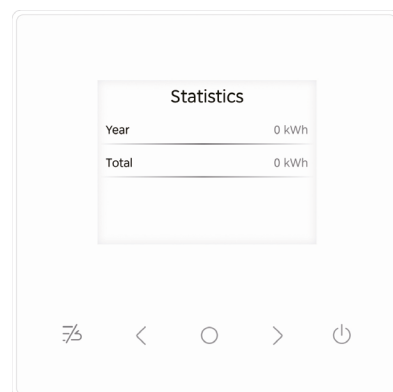
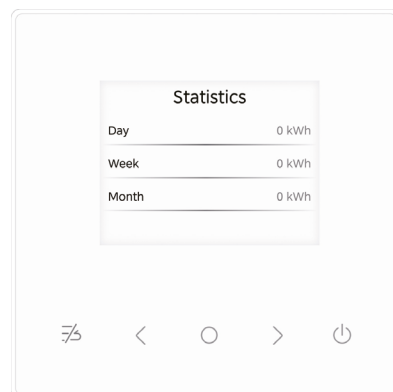

- Power Consumption Statistics

Select the Power Consumption Statistics option, press the confirmation key to enter the power consumption statistics data view. It includes data for 5 time dimensions: day, week, month, year, and cumulative.

Note:

Day, week, month, and year represent the statistical periods of the current day, current week, current month, and current year, respectively.

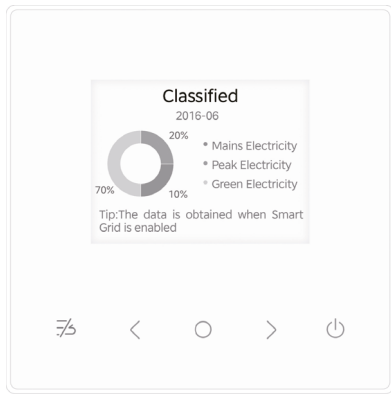

• Categorized Power Consumption

On the Energy Analysis Home Page interface, select the Categorized Power Consumption Statistics option, press the confirmation key to enter the data view. It includes data for 3 categories: grid power, high-cost power, and green power.

Note:

When the smart grid setting is ON, this item is displayed; when the smart grid setting is OFF, this item is hidden; when all three categories of power consumption are 0, the pie chart is not displayed.

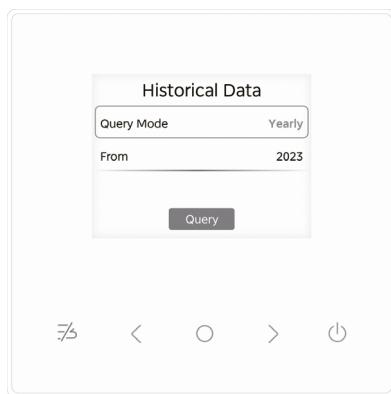
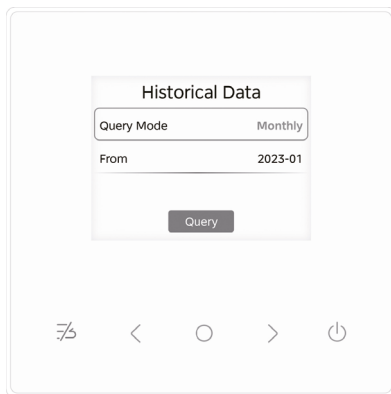

• Historical Data Query

On the Energy Analysis home screen, select the Energy Historical Data item and press the Confirm button to enter the Energy Historical Data view.

Historical energy data statistics cover the data for each month over the past 10 years, as well as the total annual data.

Supports monthly and annual queries, with the default being the monthly query method.

6.2.3.8 Help Center

By pressing the Confirm button on the main menu to select the Help Center option, you can enter the Help Center interface, where you can view Fault Information (last 20 occurrences), Operating Parameters, FAQ, and Device Information.

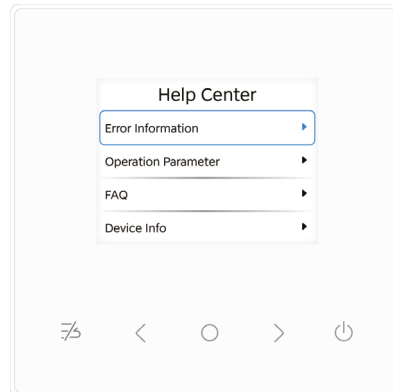

• Error Information

Error Information section, the main display shows the last 20 fault information entries: including fault codes and fault occurrence times.

No.	Code	Time
01	EL	05-15-2023 09:00
02	EL	05-16-2023 09:00
03	EL	05-17-2023 09:00
04	EL	05-18-2023 09:00

**Error Information Clear:** On the 'Error Information' page, long press the 'Confirm' button for 5 seconds to trigger the historical Error information clear function. Use the left and right buttons to select whether to clear the historical Error information. After selecting to clear, the Error information page will be emptied.

**Note:** When an error occurs, the buzzer sounds continuously three times every 300 seconds. After entering the error information page to view it, the buzzer stops.

• FAQ



Select the FAQ option on the Help Center interface and press the confirmation key to enter the FAQ interface, where you can scan the QR code to view operation instructions and common troubleshooting tips for the unit.

#### Device Information

Select the Device Information option on the Help Center interface and press the confirmation key to enter and view unit information, including the software version of the unit and the wired controller, and the SN code.

- Operation Parameters

Select the Operation Parameter option on the Help Center interface and press the confirmation key to enter the Operation Parameter interface, where you can view the unit's operating parameters and use the left and right keys to navigate through the content.

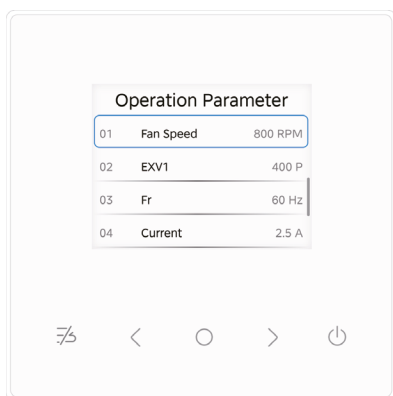

The specific operating parameter table is as follows:

Parameter	Explanations	Unit
Fan Speed	Current fan speed	RPM
EXV1	EXV opening	P
Fr	Operating frequency of the compressor	Hz
Current	Total current input	Ip
Voltage	AC voltage input	Th
Power	Total power input	W
Tp	Discharge temperature, Tp	°C/°F
Th	Suction temperature, Th	°C/°F
T3	External heat exchanger temperature, T3	°C/°F
T4	External ambient temperature, T4	°C/°F
T5	Tank temperature (upper)	°C/°F
Td	Activation temperature of E-Heater	°C/°F
Trdh	Restart offset temp. of unit	°C/°F
TrEH	Restart offset temp. of E-Heater	°C/°F
SGSL	Smart Grid signal	/
AP	Cumulative estimated power consumption	kWh
RT-HP	Real-Time Power Consumption	W
RT-PW	Real-Time Heating Power	W
Sum-HP	Cumulative Heating Capacity	kWh
COP	The energy efficiency of the unit	/
Time1	Cumulative operating time of unit	h
Time2	Cumulative operating time of compressor	h
Time3	Cumulative operating time of E-Heater	h
Oil Return	0 means Off, 1 means On	/

### 6.2.3.9 Setting

Select the Setting option by pressing the confirmation key through the main menu, enter the Setting menu, and you can configure the following: temperature unit, date & time, language, App Control, Force Defrost, Key tone, Backlight Time, Backlight Brt, Child Lock, Manual E-Heater, Manual Disinfection, Silent function.

- Temperature Unit & Date Time

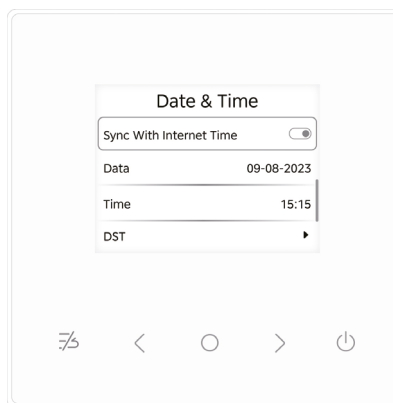
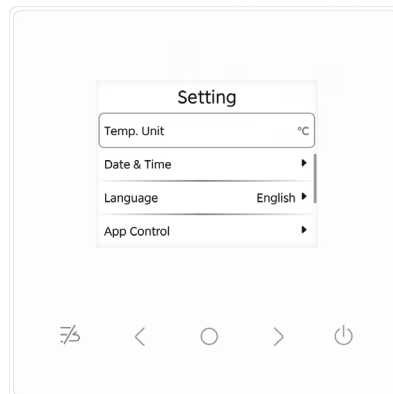

The default temperature unit is °C. Select the 'Temperature Unit' function item and press the 'Confirmation Key' to switch between °C and °F.

In the setting menu, select the date & time option and press the confirmation key to enter the setup interface, which includes network time synchronization, date, time, and daylight saving time zone settings.

#### Network Time:

In the "Date & Time" settings page, select the "Network Time" function item, click the "Confirm Key" to switch whether to follow the network time, which can be set to On, Off, with the default being Off.

On: Follow, the date and time are synchronized with the network, no settings required, the date and time settings items are grayed out and cannot be set (synchronized network time for viewing), daylight saving time is effective, and the daylight saving time setting item is not affected.

Off: Do not follow, the date, time, and daylight saving time need to be set.

When the wired controller is not connected to the network, this function does not support changing settings and is forced to Off.

#### Date Setting:

Consistent with the schedule setting. Click the "Left Key" or "Right Key" to move the cursor and select the content item to be set; click the "Confirm Key" to enter the setting of that content item, the font turns blue and blinks; click the left or right keys to adjust; after completing the adjustment setting, click the "Confirm Key" to confirm the current setting, click the "Menu Key" to return to the previous level page.

**Time Setting:**

The operation for time setting is the same as for date setting, refer to the instructions.

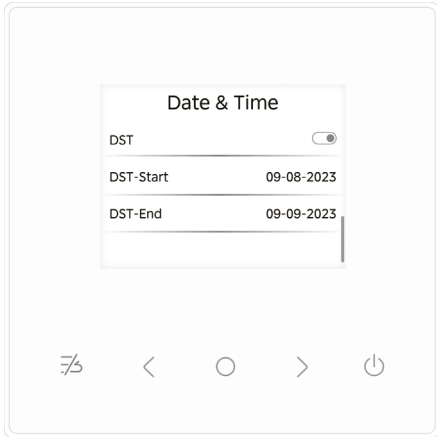

**Daylight Saving Time Setting:**

Daylight Saving Time setting includes the enable switch status for the Daylight Saving Time function (default is off), the start date, start time, end date, and end time.

When the Daylight Saving Time setting function is enabled, the start and end date and time display; when disabled, the start and end date and time setting options do not display. The setting of start and end times and dates is the same as for date and time setting, refer to the instructions.

When the system reaches the start date and time of Daylight Saving Time, the system time automatically increases by 1 hour.

When the system reaches the end date and time of Daylight Saving Time, the system time automatically decreases by 1 hour.

**Language Setting**

In the settings menu, select the language option and press the confirm key to enter language settings. There are 11 languages available: English (default), German, Spanish, Portuguese, Dutch, Italian, Simplified Chinese, Greek, Romanian, Hungarian, and French.

Use the left and right keys to switch between multiple language options, the language list cycles through, press the 'Confirm Key' to select the current language, and press the 'Menu Key' to return to the previous level interface.

• **Smart Link**

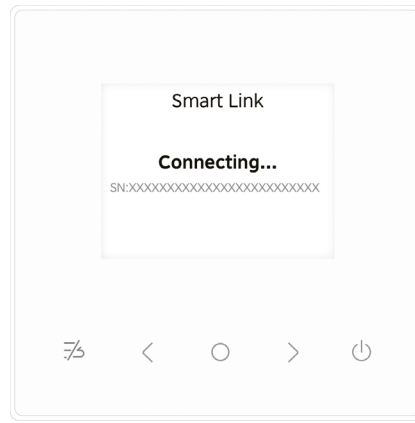
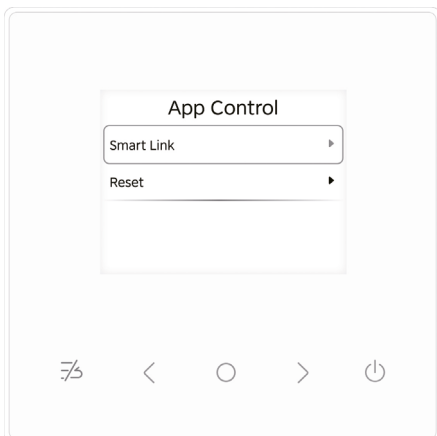

In the settings interface, select the App Control option and press the Confirm Key to enter the App Control settings;

Select the 'Smart Link' function item, press the 'Confirm Key', enter the smart network configuration state, and the network configuration prompt interface displays the SN of the wired controller;

When the device network configuration is complete, the WiFi icon is displayed at the top, or if the network configuration operation is not completed within 10 minutes, the smart network configuration prompt interface will automatically close and return to the previous menu.

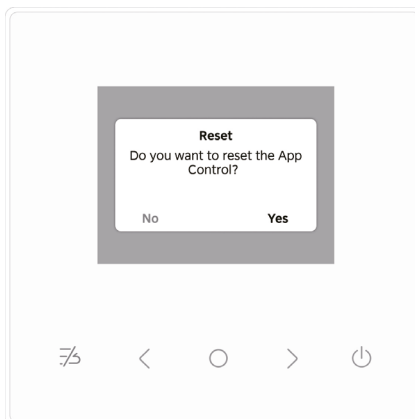
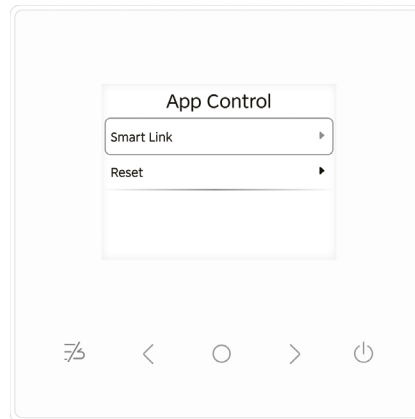

Select the Reset option, press the Confirm Key to perform a network reset, a pop-up window prompts whether to reset the APP, select No and press the Confirm Key: do not reset, exit the reset, and return to the smart network configuration page.

Select "Yes", press the "Confirm" button: The wired controller will execute a WiFi function reset, deleting all stored gateway names and password information, and exit the networked state.

- Forced Defrost

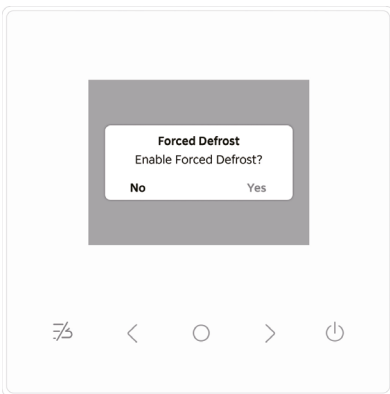
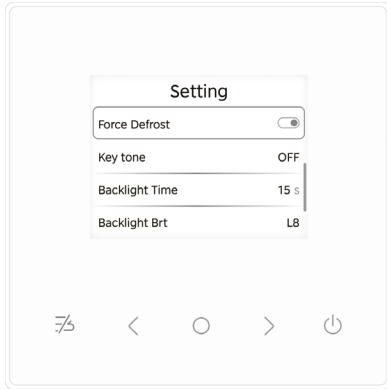

Select “No” and press the Confirm button: Forced defrost will not be performed, and the setup interface will return. The forced defrost function will remain Off.

Select “Yes” and press the Confirm button: The wired controller will return to the system setup page, and the forced defrost function will switch to On. After the unit completes defrosting, the defrost function will turn off.

**Note:**

Once the defrost function is activated, pressing the button will not turn off the defrosting process. The function will turn off automatically after defrosting is complete.

During the forced defrosting process, press the power button to turn off the unit, exit the defrosting, and switch the forced defrosting status to off.

- Backlight Time

In the setup interface, use the left and right buttons for selection and page turning, select.

Backlight time and backlight brightness, you can set the backlight time and brightness.

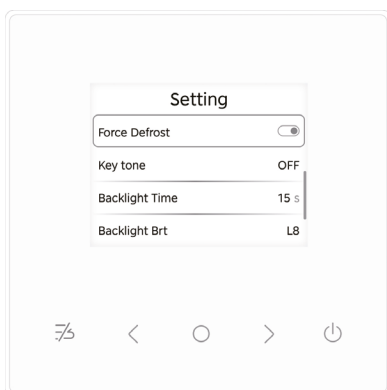

Backlight time setting: can be set to 15, 30, 60 seconds, default is 30 seconds, click the 'Confirm' button to enter the setting, use the left and right buttons to adjust the value.

Backlight brightness setting: 1~10 levels of brightness, default is 9, click the 'Confirm' button to enter the setting, use the left and right buttons to adjust the value.

- Key tone

The key tone function can be set to On, Off, default is On. When on, pressing any key provides feedback, when off, pressing keys provides no feedback. Key Click Sound Off.

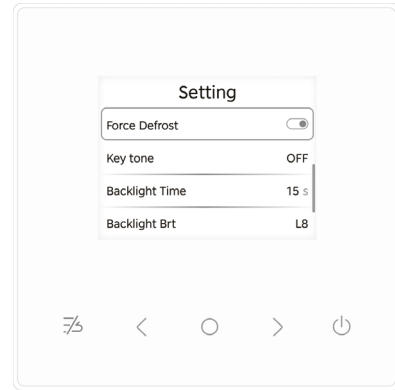

**Note**

When a fault occurs, regardless of whether the key click sound is on or off, the buzzer will sound three times every 300 seconds. After the user checks the fault information, the buzzer will stop.

- Child Lock

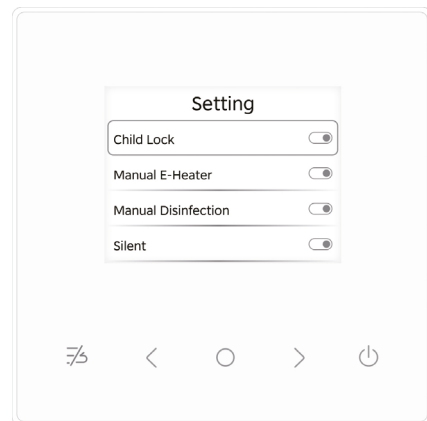

Enter the settings interface, use the left and right keys to select and navigate pages, select Child Lock option, to turn the Child Lock function on or off (default is on).

After turning on the Child Lock function, you can lock it by pressing the < and > keys simultaneously. After locking, pressing any key will prompt the unlock interface.

When set to off, the main page will not be locked, and the lock icon will not be displayed. When there is no operation, the LCD will turn off.

- Manual E-Heater

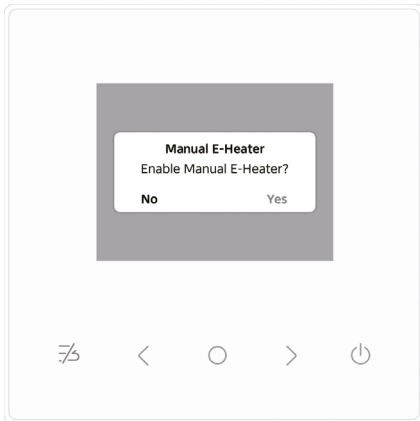
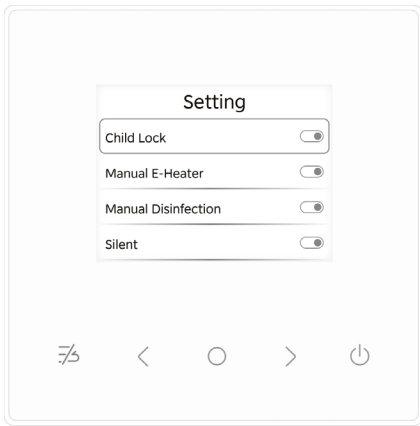

Setup Interface, use the left and right keys to select and navigate pages, select Manual E-Heater, press the confirm button to activate, after activation, a pop-up prompt will appear as follows.

Select “No” and press the confirm button: the electric heater will not be activated, return to the system settings page, the status of the manual electric heater function remains Off.

Select “Yes” and press the confirm button: the wired controller returns to the system settings page, the status of the manual electric heater function switches to On.

**Note:**

The manual electric heater function is effective for one activation only. After manual activation, once the entire unit reaches the state of electric heating shutdown or is manually (timed) turned off, the manual activation of the electric heater function will automatically turn off.

After the manual electric heater function is activated, manually clicking to turn it off will immediately switch the function status, and the electric heater will immediately turn off.

• Manual Disinfection

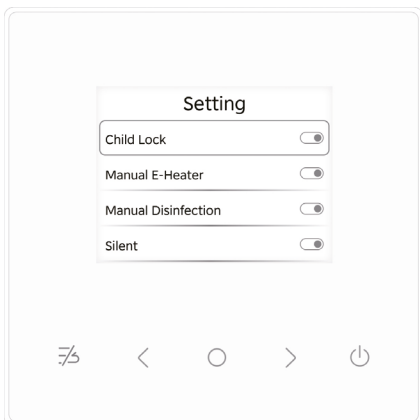

In the setup interface, use the left and right keys to select and navigate pages. Select Manual Disinfection and press the confirm button to activate. After activation, a pop-up window will appear as follows. Select No and press the confirm button: Manual disinfection will not be performed, and the system will return to the settings page, with the manual disinfection function status remaining Off.

Select Yes and press the confirm button: The wired controller will return to the system settings page, and the manual disinfection function status will switch to On.

**Note**

After the manual disinfection function is activated, once the unit meets the conditions to exit the disinfection process, the disinfection function will be deactivated, and the manual disinfection function status will switch to Off.

If the manual disinfection function is manually switched to the off state during the disinfection process, the disinfection will be immediately terminated, and the manual disinfection function status will switch to Off.

• Silent

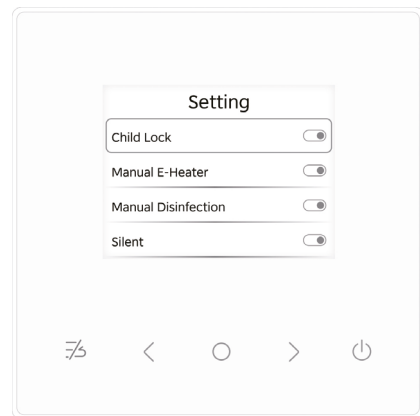

In the setup interface, use the left and right keys to select and navigate pages. Select Silent, and press the confirm key to turn the mute function on or off.

After the mute function is activated, the unit will limit the maximum frequency and fan speed, resulting in slightly lower performance compared to when it is off.

**6.2.3.10 Installation Setting**

By holding down the combination key  $\text{Esc} + \text{>}$  for three seconds to enter the installation setup interface, use the “left key” and “right key” to move the cursor to switch between functions, and the “confirm key” to adjust parameters or enter specific settings.

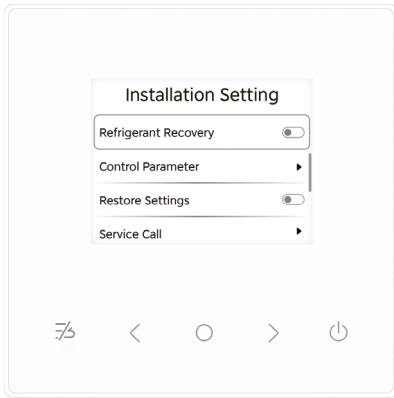

On the installation setting home page, click the “menu key” to exit the installation setup or stay on any installation setup interface for 10 minutes without operation, a pop-up will prompt whether to save the settings and exit:

Select No and press the confirm key to discard the settings and return to the current interface, select Yes and press the confirm key to save the settings and exit the installation setting interface.

Note:

The Installation setting function is for professional installers. Non-professionals should not enter this function or modify related parameters;

- Refrigerant Recovery

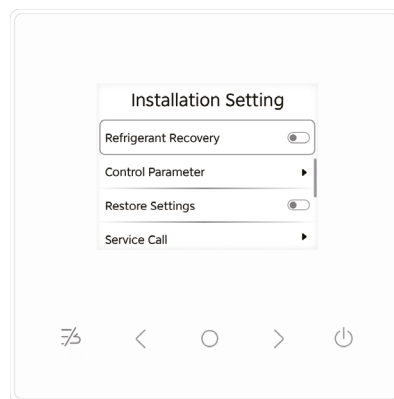

In the setup interface, use the left and right keys to make selections and navigate pages. Select Refrigerant Recovery, and press the confirm key to turn the Refrigerant Recovery function on or off.

After enabling this function, a pop-up message will appear as follows.

Select No, press the confirm key or directly press the menu key to return to the system settings page, and the Refrigerant Recovery function will remain Off.

Select Yes, press the confirm key, and the wired controller will return to the system settings page, with the Refrigerant Recovery function status switched to On.

Note

The Refrigerant Recovery function is used to recover refrigerant to the outdoor unit side before dismantling.

The function will automatically cancel after 10 minutes of activation or when manually turned off.

- Control Parameter

In the setup interface, use the left and right keys to select and page through options. Select Control Parameter and press the confirm key to enter the Control Parameter setting function.

Under Control Parameter, there are 3 parameters that can be set.

Automatic electric heater activation ambient temperature (Td), Heat pump startup hysteresis (Trdh), Electric heater activation hysteresis (TrEH).

Use the left and right keys to move the cursor to the corresponding setting item, press the confirm key to enter the setting, the setting value will flash, use the left and right keys to adjust, and press the confirm key again to confirm the setting.

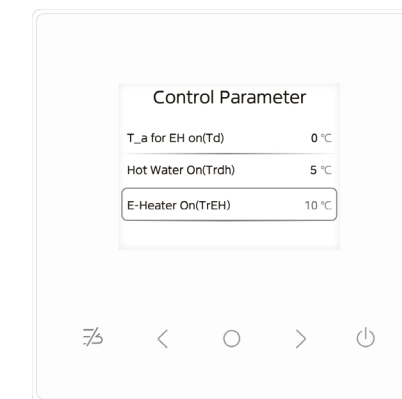

- Restore Settings

In the setup interface, use the left and right keys to select and page through options. Select “Restore Settings” and press the confirm key to activate the “Restore Settings” function;

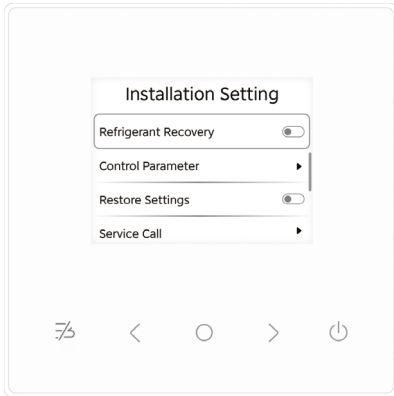

After activating the function, a pop-up window will appear as follows.

Select No, press the confirm key or directly press the menu key to return to the installation setup page.

Select Yes, press the confirmation key, the wired controller enters the factory reset interface, the interface displays the initialization percentage, after the factory reset is completed, the wired controller forcibly restarts, turns off the screen, and then turns it back on, displaying the language.

Selection interface for the first power-on.

**Note**

Factory reset will restore all settings to their default factory values. Please use with caution if there are no issues in use.

- Service Call

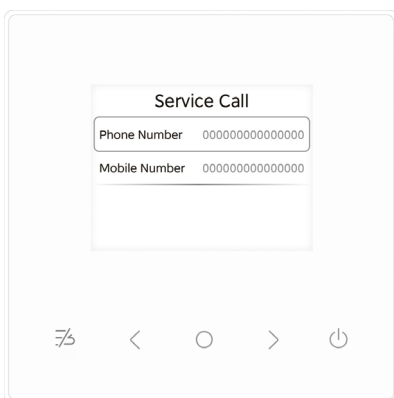

In the setup interface, use the left and right keys to make selections and navigate pages. Select Service Call and press the confirmation key to enter the Service Call setup.

Press the confirmation key to enter the phone setting.

Each digit can be set sequentially from 0~9, -, +, with the default being 0. Use the left and right keys to move the cursor to select the corresponding setting item, press the confirmation key to enter the setting, use the left and right keys to adjust, and press the confirmation key again to confirm the current setting.

- SN Rewrite

In the setup interface, use the left and right keys to make selections and navigate pages. Select SN Rewrite, and press the confirmation key to enable this function.

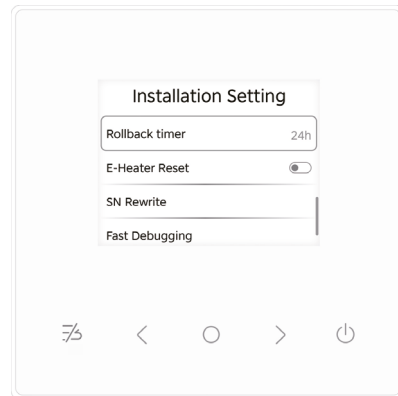

After enabling, a pop-up window will appear as follows:

Select No, click the confirmation key or directly click the menu key to return to the installation setup page, and the SN code rewrite function will not be executed.

Select Yes, click the 'confirmation key', the wired controller will execute the SN code rewrite command, sending the SN code stored in the wired controller to the unit.

**Note:**

This function is applicable for rewriting the SN code information from the original motherboard to the new motherboard after a motherboard replacement.

- Fast Debugging

In the setup interface, use the left and right keys to make selections and navigate pages. Select “Fast Debugging”, and press the confirmation key to enable the Fast Debugging function.

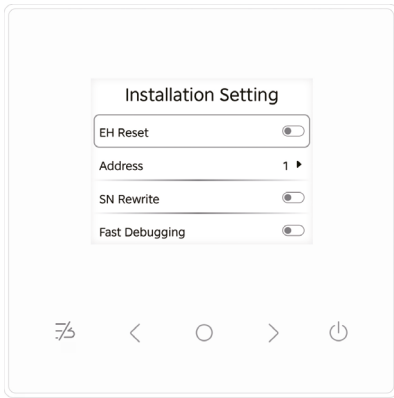

After enabling, a pop-up window will appear as follows:

Select No, click the confirmation key or directly click the menu key to return to the installation setup page, and the quick debugging function will not be executed.

Select Yes, click the 'Confirm' button, and the wired controller will execute the quick debugging command.

Note:

This function is suitable for installation and debugging in low-temperature environments (below -10 °C), skipping the low-temperature compressor preheating process.

### 6.2.3.11 Other status display

#### Remote On/Off

When the wired controller receives the d8 dry contact closure signal from the main control, the main interface displays the following screen.

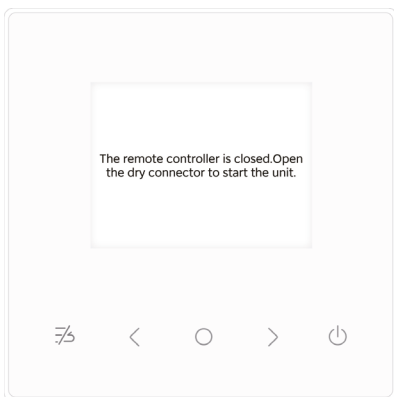

At this time, the wired controller does not accept any commands. When the d8 dry contact shorting signal is eliminated, the wired controller returns to the main interface and can be operated normally.

#### • Compressor Preheating

When the ambient temperature is below -10 °C, the compressor needs to be preheated before starting.

When the preheating start conditions are met, and the outdoor unit preheating is activated, the main interface displays the following pop-up message.

Note

During the preheating process, you can normally operate and set other parameters. When the compressor preheating is complete, this pop-up window will disappear.

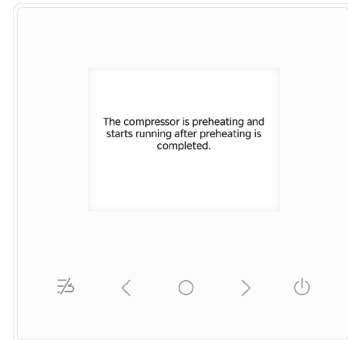

#### • OTA

The wire controller software supports OTA upgrade function, which can be accessed by pressing combination keys  $\mathbb{E} + \leftarrow$  for 3 seconds.

Whether the OTA function can update the program normally depends on whether the wire controller is correctly connected to the network. There are three situations:

① The wire controller is in a networked state and the following pop-up prompt appears. Select "yes" on the pop-up interface to enter the upgrade process;

② The wire controller is not connected to the internet, use a smart phone to approach the wire controller and set a personal hotspot. The hotspot name is "SMARTOTA" and the password is "ota12345". When the pop-up prompts to select "yes", the wire controller will automatically search for the preset hotspot name. Once the hotspot name is found, it will automatically match the preset password to complete the internet connection; After entering the network, the following update progress percentage page will be displayed, and restart after completion;

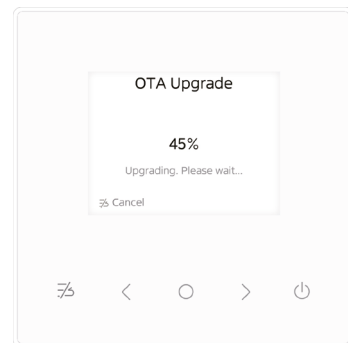

③ If the line controller cannot recognize the network after entering the OTA function, the update percentage page will continue to display 0% and restart after one minute.

### 6.2.3.12 Trouble Shooting

When the unit occurred any error, the error code will be displayed, and buzzer will sound 3 times every 300 seconds. After viewing the error information, the buzzer stops ringing. After the error is rectified, the error code and error icon disappear.

#### Error and Other Code Explanation

CODE	EXPLANATION
E0	Water flow fault (lack of water in the tank / dry burn fault)
E2	Communication malfunction between controller and main control board
E3	T5 tank temperature sensor fault
E5	ODU heat exchanger temperature sensor error (T3)
E6	ODU ambient temperature sensor error (T4)
E9	Suction temperature sensor error (Th)
EA	Discharge temperature sensor error (Tp)
EE	EEPROM chip error
EP	Leakage error of e-heater
P0	System low pressure protection (low pressure switch)
P1	System high pressure protection (high pressure switch)
P3	Over load protection of inverter compressor
P4	High discharge temperature (Tp) protection
PA	Low water temperature protection
C7	High temperature protection of inverter module
CH	Over load protection of E-heater
H1	Communication malfunction between main control board and inventor board
H4	Three times L0 protects
H6	The DC fan motor malfunction
H7	Voltage protection
HC	E-heater error (Current is less than 2 A when e-heater operating)
HH	10 times H6 in 2 hours
F2	Low super-heat of discharge protection
F6	Electric expansion valve joint fault
L0	IPM module overcurrent or weak magnetic protection (corresponding to L0x class)
L1	Module or winding high temperature protection (corresponding to L1x class)
L2	Bus voltage protection or missing phase (corresponding to L2x class)
L3	EEPROM, 337JFault Protection (upper and lower bridge), current sampling, PFC sampling bias exception (corresponding to L3x)
L4	Out of step, Zero speed protection and so on
L5	Phase loss, short circuit to ground, motor winding, inductance and other abnormal protection
LA	Phase loss, short circuit to ground, motor winding, inductance and other abnormal protection
Lb	PFC protection
bA	The ambient temperature exceeds the declared range (not an error)
bb	Low heat pump capacity

## 7 CONNECTING TO NETWORK

Normally, after network is set as ON, the controller will automatically connect to network through WiFi, then the unit will be found in iLetComfort app.

### iLetComfort appliances networking guidelines

#### (1) Download iLetComfort App

Scan the QR code below, or search for "iLetComfort" in Google play (Android devices) or App Store (ios devices) to download the App.



#### (2) Register & Log in

Step1: Register

Please enter your device brand name. If brand name can not be found or you don't know the device brand name, please enter "customer"

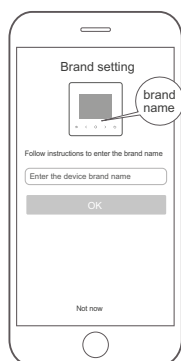

Step2: Login

Use your account to log in, if not please sign up one.

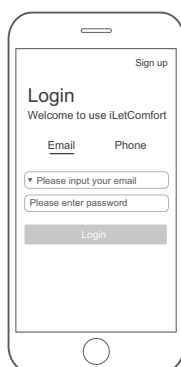

#### (3) Add your appliance

Tap the "+" icon to add device to your account.

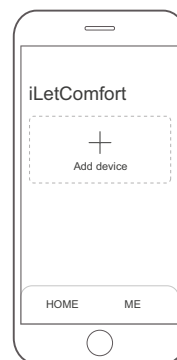

#### (4) Connected to the network

Follow the instructions in the app to set up the WiFi connection. If the network connection fails, please refer to the App tips for operation.

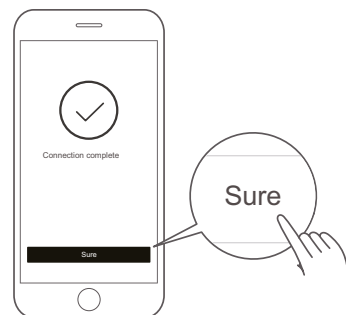

### NOTE

Notes on networking:

- When the product is connected to the network, please make sure that the mobile phone is as close as possible to the product.
- According to the App tips, if the product only supports 2.4 GHz WiFi communication, please note that the 2.4 GHz network is selected for connection.
- WiFi router SSID names contain only alphanumeric values are recommended. If special characters, punctuation marks or spaces are used it might prevent the SSID name from showing up in the available networks to join in the App. Try it and if the SSID shows up then it is ok to use, otherwise log into the router and change the SSID name.
- A large number of devices on the WiFi router can affect network stability, there is no way that manufacturer can advise a specific number limitation as this depends on router quality and many other factors.
- If the router or WiFi name and WiFi password change, please repeat the above process to reconnect to the network.
- As the product technology is updated, the content of App may change, and the actual display in App shall prevail.

#### WiFi information

WiFi transmit frequency range: 2.412 GHz to 2.484 GHz  
EIRP not more than 20 dBm

#### BLE information

BLE transmit frequency range: 2.402 GHz to 2.480 GHz  
EIRP not more than 10 dBm

## 8 OPERATIONS

### CAUTION

Please cut off the manual switch power when unit fails. Do not restart until problems are solved.

#### 1) Characteristics of water heating—3 minute protection

Restart or open manual switch after the unit has been shut down within a short time. Unit will not start immediately until 3 minutes later, because of the self-protect function of the compressor.

#### 2) During operation, if outdoor temperature is higher than normal, the fan motor will runs at low air volume or stop running.

#### 3) About defrosting function perform at heating operation

- In case of frosting during heating operation, to prevent the heating efficiency from decreasing, defrosting operation will turn on automatically (Approx. 2~7 minutes) .
- In the process of defrosting operation, the unit fan motor will stop running.

#### 4) About protection device

- When protection device operate, though the unit stops, the operating indicator of wire control still will be blinking.
- When protection device operates, nixie indicator will display malfunction code (unit).
- Protection device will act when the following circumstances occur:
  - a) Air inlet or outlet are blocked.
  - b) Voltage is a little higher or lower compare to the voltage range (Exceeding the range of -10 %~10 % of 230 V).

Do not use means to accelerate the defrosting process or to clean, other than those recommended by the manufacturer.

#### 5) Start the unit after a long period out of service

Start-up the unit after out of service for a long period (includes drive up a unit at the first time), you would see rust mix up water in red, flow out from tap. Such that is a normal phenomenon, please be calmly and keep draining, after for a while rust will disappear.

#### 6) About power failure

- In case power failure during the unit working, please stop all operating actions.
- At the next startup after power failure, the RUN indicator of wire controller will blink slowly for several seconds for noting user.
- Misoperation occur during unit working.

#### 7) About RCCB

Outdoor unit must use RCCB, please install an RCCB between in user power supply and the outdoor unit. In case the unit cannot act but not attribute to power failure, please check these RCCB switches at first. Before operate the RCCB, please ensure that the user installing switch is break off.

#### 8) About start/stop control

The user can set the target water temperature and dead band temperature on the wired controller. When the upper temperature sensor of the water tank detects that the water temperature is lower than the difference value between the target water temperature and the dead band, the controller will start the heat pump heating until the upper water temperature of the water tank reaches the target water temperature and then stop.

#### 9) About energy consumption

If the user sets the water temperature to be higher than the suggestive value (54 °C), or sets the dead band to be less than the default value (5 °C), that will cause an increase in energy consumption of the unit.

#### 10) About legionella control method

The unit will perform disinfection operation weekly (default between 1:00 am and 6:00 am). During disinfection, the temperature sensor at the bottom of the water tank will be used to control the heat pump operation to heat more than 90 % of the water to above 60 °C and maintaining it for at least 32 minutes. At this time, the maximum outlet temperature of the water tank will exceed 60 °C.

#### 11) About boost e-heater

The e-heater is installed in the lower part of the water tank and shares the water temperature sensor control with the heat pump. It is used to replace the heat pump to heat the water tank when exceeding the operating range of the heat pump (ambient temperature range: -15 °C to 46 °C), or to activate it when the ambient temperature is lower than Td and the water temperature is lower than the value of the difference between target and dead band, or to activate it manually when boost heating is occasionally needed, or to use it in emergency when the heat pump system malfunctions.

## 9 SERVICE AND MAINTENANCE

### 1) Checks to the area

Prior to beginning work on systems containing flammable refrigerants, safety checks are necessary to ensure that the risk of ignition is minimised. For repair to the refrigerating system, DD.4.3 to DD.4.7 shall be completed prior to conducting work on the system. Electrical components that can arc or spark, which are not considered ignition sources due to compliance with 22.116.1 points b), c), d), or f) shall only be replaced with parts specified by the appliance manufacturer. Replacement with other parts may result in the ignition of refrigerant in the event of a leak;

### 2) Work procedure

Works shall be undertaken under a controlled procedure so as to minimise the risk of a flammable gas or vapour being present while the work is being performed.

### 3) General work area

All maintenance staff and others working in the local area shall be instructed on the nature of work being carried out. Work in confined spaces shall be avoided. The area around the work space shall be sectioned off. Ensure that the conditions within the area have been made safe by control of flammable material.

### 4) Checking for presence of refrigerant

The area shall be checked with an appropriate refrigerant detector prior to and during work, to ensure the technician is aware of potentially flammable atmospheres. Ensure that the leak detection equipment being used is suitable for use with flammable refrigerants, i.e. no sparking, adequately sealed or intrinsically safe.

### 5) Presence of fire extinguisher

If any hot work is to be conducted on the refrigeration equipment or any associated parts, appropriate fire extinguishing equipment shall be available to hand. Have a dry power or CO<sub>2</sub> fire extinguisher adjacent to the charging area.

### 6) No ignition sources

No person carrying out work in relation to a refrigeration system which involves exposing any pipe work that contains or has contained flammable refrigerant shall use any sources of ignition in such a manner that it may lead to the risk of fire or explosion. All possible ignition sources, including cigarette smoking, should be kept sufficiently far away from the site of installation, repairing, removing and disposal, during which flammable refrigerant can possibly be released to the surrounding space. Prior to work taking place, the area around the equipment is to be surveyed to make sure that there are no flammable hazards or ignition risks. NO SMOKING signs shall be displayed.

### 7) Ventilated area

Ensure that the area is in the open or that it is adequately ventilated before breaking into the system or conducting any hot work. A degree of ventilation shall continue during the period that the work is carried out. The ventilation should safely disperse any released refrigerant and preferably expel it externally into the atmosphere.

### 8) Checks to the refrigeration equipment

Where electrical components are being changed, they shall be fit for the purpose and to the correct specification. At all times the manufacturer's maintenance and service guidelines shall be followed. If in doubt consult the manufacturer's technical department for assistance. The following checks shall be applied to installations using flammable refrigerants.

- The charge size is in accordance with the room size within which the refrigerant containing parts are installed.
- The ventilation machinery and outlets are operating adequately and are not obstructed.
- If an indirect refrigerating circuit is being used, the secondary circuits shall be checked for the presence of refrigerant; marking to the equipment continues to be visible and legible.
- Marking and signs that are illegible shall be corrected.
- Refrigeration pipe or components are installed in a position where they are unlikely to be exposed to any substance which may corrode refrigerant containing components, unless the components are constructed of materials which are inherently resistant to being corroded or are suitably protected against being so corroded.

### 9) Checks to electrical devices

Repair and maintenance to electrical components shall include initial safety checks and component inspection procedures. If a fault exists that could compromise safety, then no electrical supply shall be connected to the circuit until it is satisfactorily dealt with. If the fault cannot be corrected immediately but it is necessary to continue operation, and adequate temporary solution shall be used. This shall be reported to the owner of the equipment so all parties are advised.

Initial safety checks shall include:

- That capacitors are discharged: this shall be done in a safe manner to avoid possibility of sparking.
- That there are no live electrical components and wiring are exposed while charging, recovering or purging the system.
- That there is continuity of earth bonding.

### 10) Repairs to sealed components

a) During repairs to sealed components, all electrical supplies shall be disconnected from the equipment being worked upon prior to any removal of sealed covers, etc. If it is absolutely necessary to have an electrical supply to equipment during servicing, then a permanently operating form of leak detection shall be located at the most critical point to warn of a potentially hazardous situation.

b) Particular attention shall be paid to the following to ensure that by working on electrical components, the casing is not altered in such a way that the level of protection is affected. This shall include damage to cables, excessive number of connections, terminals not made to original specification, damage to seals, incorrect fitting of glands, etc.

Ensure that apparatus is mounted securely.

Ensure that seals or sealing materials have not degraded such that they no longer serve the purpose of preventing the ingress of flammable atmospheres. Replacement parts shall be in accordance with the manufacturer's specifications.

The use of silicon sealant may inhibit the effectiveness of some types of leak detection equipment. Intrinsically safe components do not have to be isolated prior to working on them.

#### 11) Repair to intrinsically safe components

Do not apply any permanent inductive or capacitance loads to the circuit without ensuring that this will not exceed the permissible voltage and current permitted for the equipment in use. Intrinsically safe components are the only types that can be worked on while live in the presence of a flammable atmosphere. The test apparatus shall be at the correct rating. Replace components only with parts specified by the manufacturer. Other parts may result in the ignition of refrigerant in the atmosphere from a leak.

#### 12) Cabling

Check that cabling will not be subject to wear, corrosion, excessive pressure, vibration, sharp edges or any other adverse environmental effects. The check shall also take into account the effects of aging or continual vibration from sources such as compressors or fans.

#### 13) Detection of flammable refrigerants

Under no circumstances shall potential sources of ignition be used in the searching for or detection of refrigerant leaks. A halide torch (or any other detector using a naked flame) shall not be used.

#### 14) Leak detection methods

The following leak detection methods are deemed acceptable for systems containing flammable refrigerants. Electronic leak detectors may be used to detect refrigerant leaks but, in the case of flammable refrigerants, the sensitivity can be inadequate, or can need re-calibration. (Detection equipment shall be calibrated in a refrigerant-free area.) Ensure that the detector is not a potential source of ignition and is suitable for the refrigerant. Leak detection equipment shall be set at a percentage of the LFL of the refrigerant and shall be calibrated to the refrigerant employed and the appropriate percentage of gas (25 % maximum) is confirmed. Leak detection fluids are also suitable for use with most refrigerants but the use of detergents containing chlorine shall be avoided as the chlorine can react with the refrigerant and corrode the copper pipe-work. If a leak is suspected, all naked flames shall be removed or extinguished. If a leakage of refrigerant is found which requires brazing, all of the refrigerant shall be recovered from the system, or isolated (by means of shut off valves) in a part of the system remote from the leak. Oxygen free nitrogen (OFN) shall then be purged through the system both before and during the brazing process. Compressed air or oxygen shall not be used for purging refrigerant systems.

#### 15) Removal and evacuation

When breaking into the refrigerant circuit to make repairs or for any other purpose conventional procedures shall be used. However, it is important that best practice is followed since flammability is a consideration. The following procedure shall be adhered to:

- Remove refrigerant;
- Purge the circuit with inert gas;
- Evacuate;
- Purge again with inert gas;
- Open the circuit by cutting or brazing.

The refrigerant charge shall be recovered into the correct recovery cylinders. The system shall be flushed with OFN to render the unit safe. This process may need to be repeated several times.

Compressed air or oxygen shall not be used for this task. Purging of the refrigerant circuit shall be achieved by breaking the vacuum in the system with inert gas and continuing to fill until the working pressure is achieved, then venting to atmosphere, and finally pulling down to a vacuum. An inert gas should use dry nitrogen. This process shall be repeated until no refrigerant is within the system.

When the final OFN charge is used, the system shall be vented down to atmospheric pressure to enable work to take place. This operation is absolutely vital if brazing operations on the pipe-work are to take place.

Ensure that the outlet for the vacuum pump is not closed to any ignition sources and there is ventilation available.

#### 16) Charging procedures

In addition to conventional charging procedures, the following requirements shall be followed:

- Ensure that contamination of different refrigerants does not occur when using charging equipment. Hoses or lines shall be as short as possible to minimize the amount of refrigerant contained in them.
- Cylinders shall be kept in an appropriate position according to the instructions.
- Ensure that the refrigeration system is earthed prior to charging the system with refrigerant.
- Label the system when charging is complete (if not already).
- Extreme care shall be taken not to overfill the refrigeration system.
- Prior to recharging the system, it shall be pressure-tested with the appropriate purging gas. The system shall be leak tested on completion of charging but prior to commissioning. A follow up leak test shall be carried out prior to leaving the site.

## 17) Decommissioning

Before carrying out this procedure, it is essential that the technician is completely familiar with the equipment and all its detail.

It is recommended good practice that all refrigerants are recovered safely. Prior to the task being carried out, an oil and refrigerant sample shall be taken.

In case analysis is required prior to re-use of reclaimed refrigerant. It is essential that electrical power is available before the task is commenced.

a) Become familiar with the equipment and its operation.

b) Isolate system electrically

c) Before attempting the procedure ensure that:

- Mechanical handling equipment is available, if required, for handling refrigerant cylinders.
- All personal protective equipment is available and being used correctly.
- The recovery process is supervised at all times by a competent person.
- Recovery equipment and cylinders conform to the appropriate standards.

d) Pump down refrigerant system, if possible.

e) If a vacuum is not possible, make a manifold so that refrigerant can be removed from various parts of the system.

f) Make sure that cylinder is situated on the scales before recovery takes place.

g) Start the recovery machine and operate in accordance with manufacturer's instructions.

h) Do not overfill cylinders. (No more than 80 % volume liquid charge).

i) Do not exceed the maximum working pressure of the cylinder, even temporarily.

j) When the cylinders have been filled correctly and the process completed, make sure that the cylinders and the equipment are removed from site promptly and all isolation valves on the equipment are closed off.

k) Recovered refrigerant shall not be charged into another refrigeration system unless it has been cleaned and checked.

## 18) Labelling

Equipment shall be labelled stating that it has been de-commissioned and emptied of refrigerant. The label shall be dated and signed. Appliances containing flammable refrigerants, ensure that there are labels on the equipment stating the equipment contains flammable refrigerant.

## 19) Recovery

When removing refrigerant from a system, either for service or decommissioning, it is recommended good practice that all refrigerants are removed safely.

When transferring refrigerant into cylinders, ensure that only appropriate refrigerant recovery cylinders are employed. Ensure that the correct numbers of cylinders for holding the total system charge are available. All cylinders to be used are designated for the recovered refrigerant and labelled for that refrigerant (i.e. special cylinders for the recovery of refrigerant). Cylinders shall be complete with pressure relief valve and associated shut-off valves in good working order.

Empty recovery cylinders are evacuated and, if possible, cooled before recovery occurs.

The recovery equipment shall be in good working order with a set of instructions concerning the equipment that is at hand and shall be suitable for the recovery of flammable refrigerants. In addition, a set of calibrated weighing scales shall be available and in good working order.

Hoses shall be complete with leak-free disconnect couplings and in good condition. Before using the recovery machine, check that it is in satisfactory working order, has been properly maintained and that any associated electrical components are sealed to prevent ignition in the event of a refrigerant release. Consult manufacturer if in doubt.

The recovered refrigerant shall be returned to the refrigerant supplier in the correct recovery cylinder, and the relevant Waste Transfer Note arranged. Do not mix refrigerants in recovery units and especially not in cylinders.

If compressors or compressor oils are to be removed, ensure that they have been evacuated to an acceptable level to make certain that flammable refrigerant does not remain within the lubricant. The evacuation process shall be carried out prior to returning the compressor to the suppliers. The compressor body shall not be heated by an open flame or other ignition sources to accelerate this process. When oil is drained from a system, it shall be carried out safely.

## 20) Transportation, marking and storage for units

Transport of equipment containing flammable refrigerants Compliance with the transport regulations.

Marking of equipment using signs Compliance with local regulations.

Disposal of equipment using flammable refrigerants Compliance with national regulations.

Storage of equipment/appliances.

The storage of equipment should be in accordance with the manufacturer's instructions.

Storage of packed (unsold) equipment.

Storage package protection should be constructed such that mechanical damage to the equipment inside the package will not cause a leak of the refrigerant charge.

The maximum number of pieces of equipment permitted to be stored together will be determined by local regulations.

21) If other professionals are needed to assist in maintaining and repairing equipment, they should be supervised by personnel qualified to use flammable refrigerants.

22) Precautions shall be taken to avoid excessive vibration or pulsation to refrigerating piping. Provision shall be made for expansion and contraction of long runs of piping. Piping in refrigerating systems shall be so designed and installed as to minimize the likelihood of hydraulic shock damaging the system. Solenoid valves shall be correctly positioned in the piping to avoid hydraulic shock. Solenoid valves shall not block in liquid refrigerant unless adequate relief is provided to the refrigerant system low pressure side. Steel pipes and components shall be protected against corrosion with a rustproof coating before applying any insulation. Protection devices, piping and fittings shall be protected as far as possible against adverse environmental effects, for example the danger of water collecting and freezing in relief pipes or the accumulation of dirt and debris. Instructions for wiring to external zoning dampers and/or mechanical ventilation, if required to comply with Clause GG.9, to ensure that upon detection of a leak, the zoning dampers are driven fully open and additional mechanical ventilation is activated.

## 9.1 Confirmation before running

- 1) Make sure whether ground wire is broken or fall off.
- 2) Power on the machine after all connections are qualified.

## 9.2 Troubleshooting when abnormal situation happens

Before asking for serving or repairing, check the following points:

- Non-mechanical malfunction
  - 1) Water oozes from safety valve pressure relief opening
    - When water heating, cold water will expand when heated, water oozing is normal. Do not block it for safety consideration.
    - If a large amount of water flows, it means safety valve is invalid. Stop using and replace safety valve.
  - 2) Long period for heating a tank of water
    - In winter, water heating efficiency will decrease because of low ambient temperature (about 0 °C).It will take a longer time for water heating.
    - If customer needs to use hot water, please start the until in advance.
- Need to check
  - 1) Automatically start or stop
    - Whether we set timer wrongly
  - 2) When not working
    - Check whether powering on
    - Whether manual switch is on
    - Whether fuse blows
    - Whether start the protection device (indicator lights)
    - Whether it is not the time of timer on. (Operation lamp lights.)
  - 3) If heating effect is not good
    - Whether air outlet and inlet has been blocked

### CAUTION

- If the following situation happens, please stop running and cut off power supply manually and contact with the dealer or service center.
  - ON/OFF operation is ineffective.
  - Fuse or RCCB trips frequently
- Before leave unused for a long time, please complete the following items:
  - Drain water from tank and pipes, close all valve bodies.
- After leave unused for a long time, please check the following items:
  - Check air inlet and outlet of the unit to see whether they are blocked. Clean immediately when they are blocked.
  - Check whether water pipes, valves have been damages or blocked. Whether there's water leakage in joints, replace them when water leaks.
  - It is suggest to inspect anode protection material every half year. If it has been exhausted, please replace it with a new one.

## 9.3 After-sale service

In case of malfunctions, please cut off the power switch and contact after-sale service centre or technical service department, for detailed information please refer to User Service Guide.

## 9.4 Important information for the used refrigerant

This product has flammable gas, it is forbidden to install in an enclosed space.

Refrigerant type: R454C; Value of GWP: 146;

GWP=Global Warming Potential

Table 10-1

Factory charge	
Refrigerant/kg	tonnes CO <sub>2</sub> equivalent
0.9	0.13051

## ⚠ WARNING

### Frequency of Refrigerant Leak Checks:

1. For equipment that contains fluorinated greenhouse gases in quantities of 5 tonnes of CO<sub>2</sub> equivalent or more, but of less than 50 tonnes of CO<sub>2</sub> equipment, at least every 12 months, or where a leakage detection system is installed, at least every 24 months.
2. For equipment that contains fluorinated greenhouse gases in quantities of 50 tonnes of CO<sub>2</sub> equivalent or more, but of less than 500 tonnes of CO<sub>2</sub> equipment, at least every six months, or where a leakage detection system is installed, at least every 12 months.
3. For equipment that contains fluorinated greenhouse gases in quantities of 500 tonnes of CO<sub>2</sub> equivalent or more, at least every three months, or where a leakage detection system is installed, at least every six months.
4. Non-hermetically sealed equipment charged with fluorinated greenhouse gases shall only be sold to the end user where evidence is provide that the installation is to be carried out by an undertaking certified person.
5. Only certificated person is allowed to do installation, operation and maintenance.

## 9.5 Water quality limitations

### 👉 NOTE

If the water quality does not meet the requirements in the table below, please contact the supplier for advice.

Table 10-2

PH Value	Total Hardness	Electrical Conductivity
6.5 - 8.0	50 ppm	< 200 µS/cm (25 °C)
Sulphate Ion	Silicon	Iron Content
< 50 ppm	< 30 ppm	< 0.3 ppm
Sulfide Ion	Chloride Ion	Ammonia Ion
None	< 50 ppm	None
Sodium Ion	Calcium Ion	_____
None	< 50 ppm	_____

## 9.6 About maintenance

### 9.6.1 About refrigerant recovery

If the water tank needs to be replaced, the refrigerant needs to be recycled to the unit. The operation method for refrigerant recovery is as follows:

At first, when the controller of the unit is turned on, activate the refrigerant recovery function according to the operating instructions of the controller.

After blowing out hot air from the unit, then shut the liquid side refrigerant stop valve (the smaller one) of the unit.

After the temperature of the air blown out is close to ambient temperature, shut the gas side refrigerant stop valve (the bigger one), then cut off the power, and the refrigerant recovery is completed.

### 9.6.2 About vacuuming

#### 9.6.2.1 Purpose

Vacuum drying should be performed in order to remove moisture and non-condensable gases from the system. Removing moisture prevents ice formation and oxidization of copper piping or other internal components. The presence of ice particles in the system would cause abnormal operation, whilst particles of oxidized copper can cause compressor damage. The presence of non-condensable gases in the system would lead to pressure fluctuations and poor heat exchange performance.

#### 9.6.2.2 Procedure

### ⚠ CAUTION

- When installing for the first time, there is no need to vacuum because the water tank and connecting pipes (included in the accompanying accessories) are already pre filled with refrigerant.
- Vacuuming is needed after having finished field maintenance of refrigerant system without disconnecting outdoor unit, water tank and connection pipes.
- When vacuuming after maintenance, make sure that there are no open flames or sparks to prevent explosion or ignition.

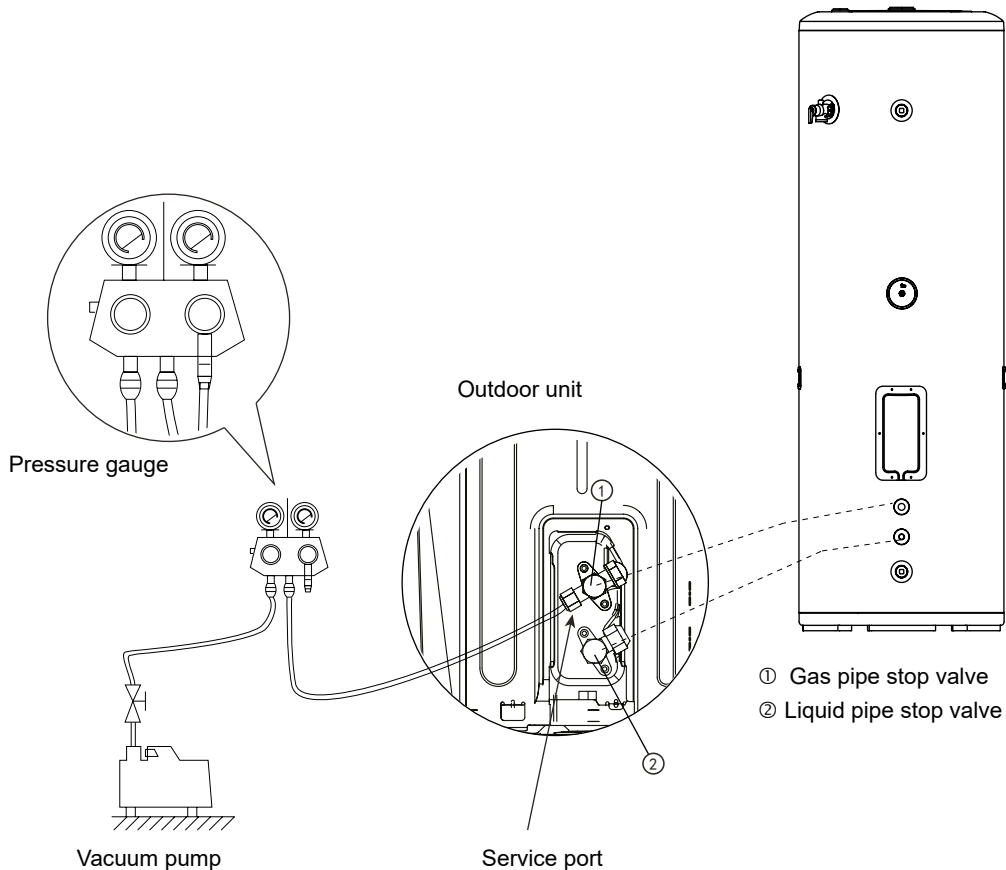
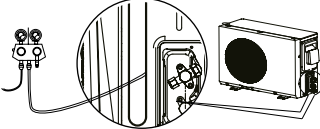
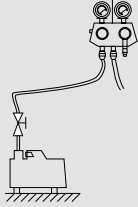
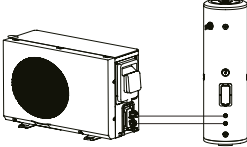

Table 10-3

ITEM	DESCRIPTION	IMAGE	NOTICE
1	Connect the (low pressure side) hose of a pressure gauge to the outdoor unit gas pipe stop valve.		Before performing vacuum drying, make sure that all the outdoor unit stop valves are firmly closed.
2	Connect the hose to the vacuum pump.		<p>1. Mixing of pump lubricant with compressor oil could cause compressor malfunction and a one-way valve should therefore be used to prevent vacuum pump lubricant seeping into the piping system.</p> <p>2. Using a vacuum pump with a discharge in excess of 4 L/s and a precision level of 0.02 mmHg is recommended.</p>
3	Connect the outdoor unit stop valve to water tank connection		
4	Start the vacuum pump and then open the pressure gauge valves to start vacuum the system.		
5	After 15-20 minutes, close the pressure gauge valves.		
6	After a further 5 to 10 minutes check the pressure gauge. If the gauge is no change, then vacuum drying is OK. If the gauge has returned to zero, check for leakages in the refrigerant piping, then fix them.		
7	After leakages are fixed, re-open the pressure gauge valves and continue vacuum drying for at least 20 minutes and until a pressure difference of 756 mmHg or more has been achieved. Once the pressure difference of at least 756 mmHg has been achieved, continue vacuum drying for 20 minutes.		
8	Close the pressure gauge valves and then stop the vacuum pump.		
9	After 1 hour, check the pressure gauge. If the pressure in the piping has not increased, the procedure is finished. If the pressure has increased, check for leakages.		After vacuum drying, keep the hoses connected to the pressure gauge and to the outdoor unit stop valves, in preparation for refrigerant charging.

9.6.3 Refrigerant charge

- If there is no refrigerant in the system after maintenance, it is necessary to recharge the refrigerant after completing the vacuum pumping operation.
- The weight of refrigerant recharge should be calculated according to the following rules:  
 If the pipe length is less than 10 meters, the recharge weight of refrigerant 900 g.  
 If the pipe length is more than 10 meters, adding additional refrigerant charge is necessary, and the rule is 20 g/m for the additional pipe length.  
 For example, installing a pipeline length of 15 m (one-way liquid pipe length) and adding a refrigerant volume of 20\* (15-10)=100 g.

NOTE

---

A series of horizontal dotted lines for writing.

MUNDO  CLIMA®



[www.mundoclima.com](http://www.mundoclima.com)

C/ ROSSELLÓ, 430-432  
08025 BARCELONA  
ESPAÑA/SPAIN  
(+34) 93 446 27 80  
SAT:(+34) 93 652 53 57