

# CHILLER INVERTER H12

## Technical manual

### MUENR-H12T / MUENR-H12T(K)

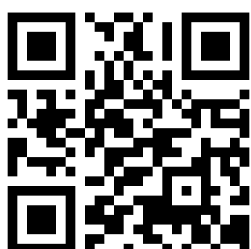

---

# CONTENTS

**Part 1 General Information..... 3**

**Part 2 Engineering Data ..... 14**

**Part 3 Installation and Field Settings..... 48**



# Part 1

## General Information

1 System introduction .....	4
2 Product lineup.....	10
3 Nomenclature .....	10
4 System Design And Unit Selection .....	11

# 1 System introduction

## 1.1 System Schematic

MUENR-H12T/H12T(K) is an integrated air-to-water space heating and space cooling heat pump system. The outdoor heat pumpsystem extracts heat from the outdoor air and transfers this heat through refrigerant piping to the plate heat exchanger in thehydronic system. The heated water in the hydronic system circulates to low temperature heat emitters (floor heating loops orlow temperature radiators) to provide space heating. The 4-way valve in the outdoor unit can reverse the refrigerant cycle sothat the hydronic system can provide chilled water for cooling using fan coil units.

The heating capacity of heat pumps decreases with ambient temperature. MUENR-H12T/H12T(K) is reserved an auxiliary electricheater control port to provide additional heating capacity for use during extremely cold weather when the heat pump capacity isinsufficient. The auxiliary electric heater also serves as a backup in case of heat pump malfunction and for anti-freeze protectionof the outside water piping in winter.

## 1.2 Typical Applications

### 1.2.1 Space Heating Through Floor Heating Loops

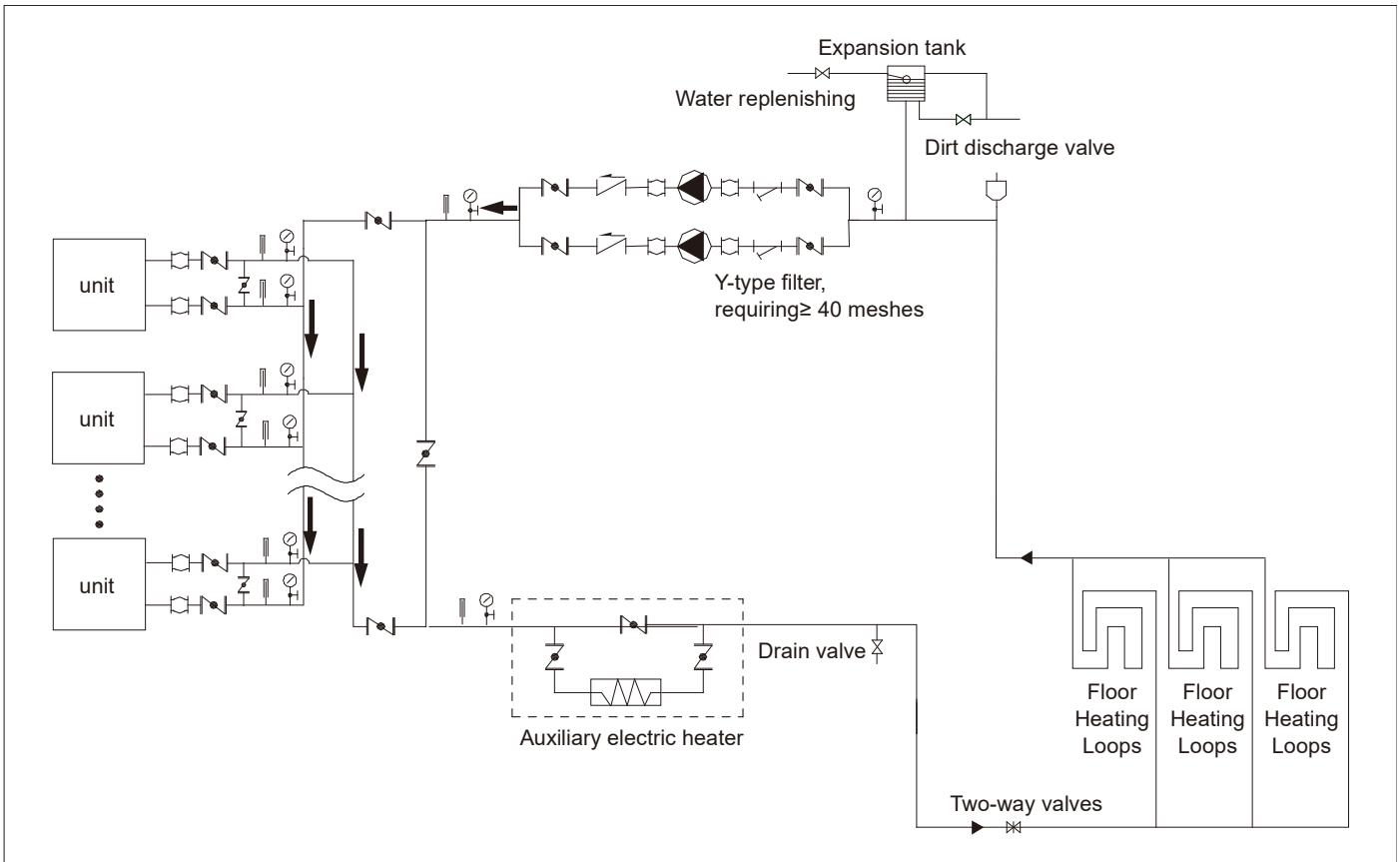

Legend				
Stop valve	Pressure gauge	Flexible joint	Gate valve	Automatic discharge valve
Y-shaped filter	Thermometer	Circulating pump	Check valve	

# 1

## Machine with water pump

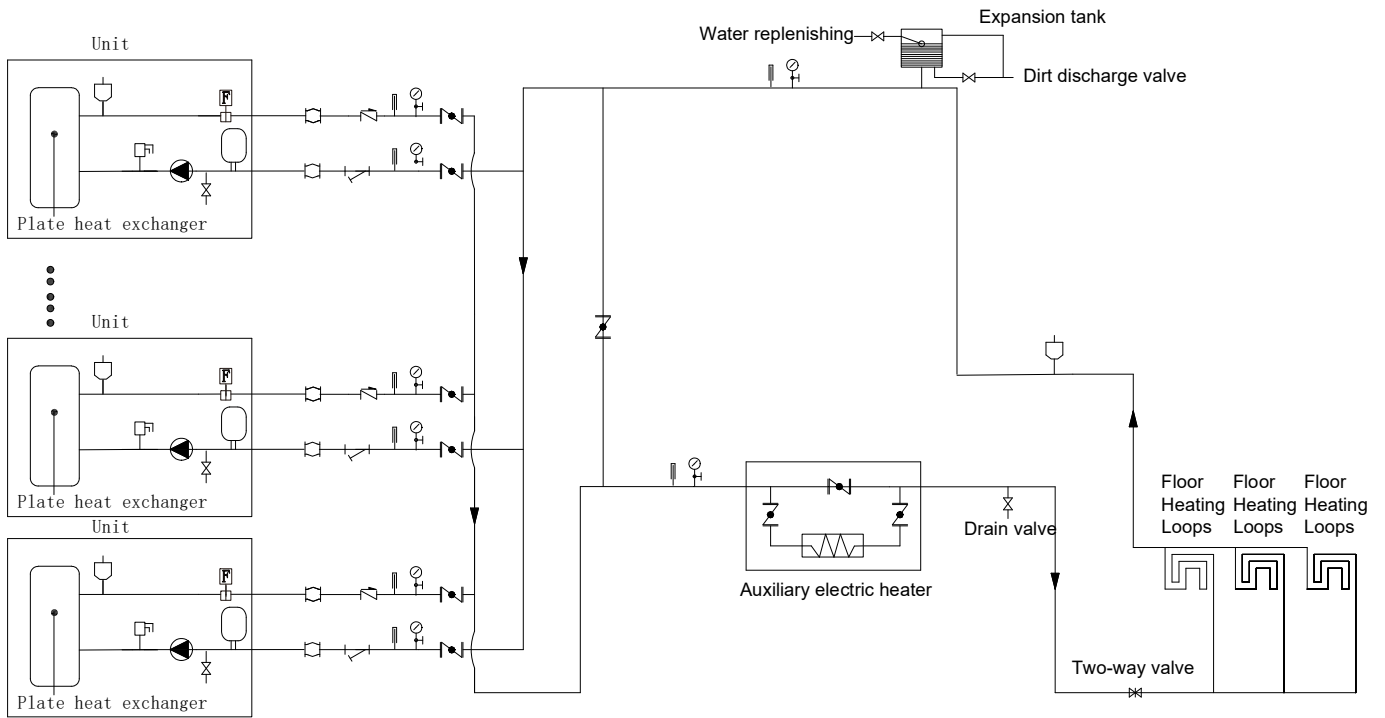

Water flow switch	Safety valve	Expansion tank	Drain valve	Atmospheric exhaust valve
Soft joint	Pump	Shut off valve	Y-filter	Solenoid three-way valve
Water pressure instrument	Check valve	Thermometer		

### 1.2.2 Space Cooling and Heating through Fan Coil Unit

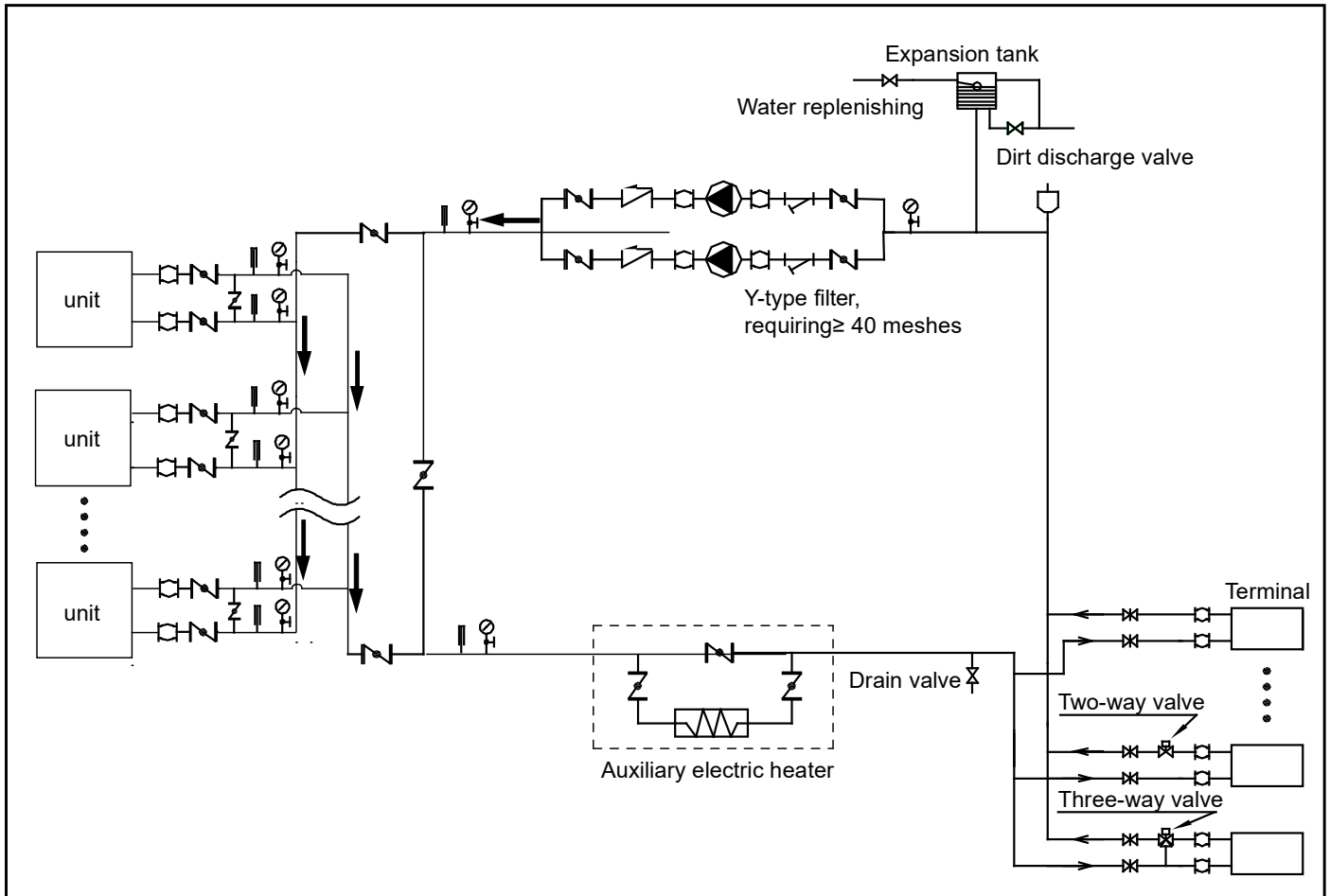

Legend				
Stop valve	Pressure gauge	Flexible joint	Gate valve	Automatic discharge valve
Y-shaped filter	Thermometer	Circulating pump	Check valve	

Machine with water pump

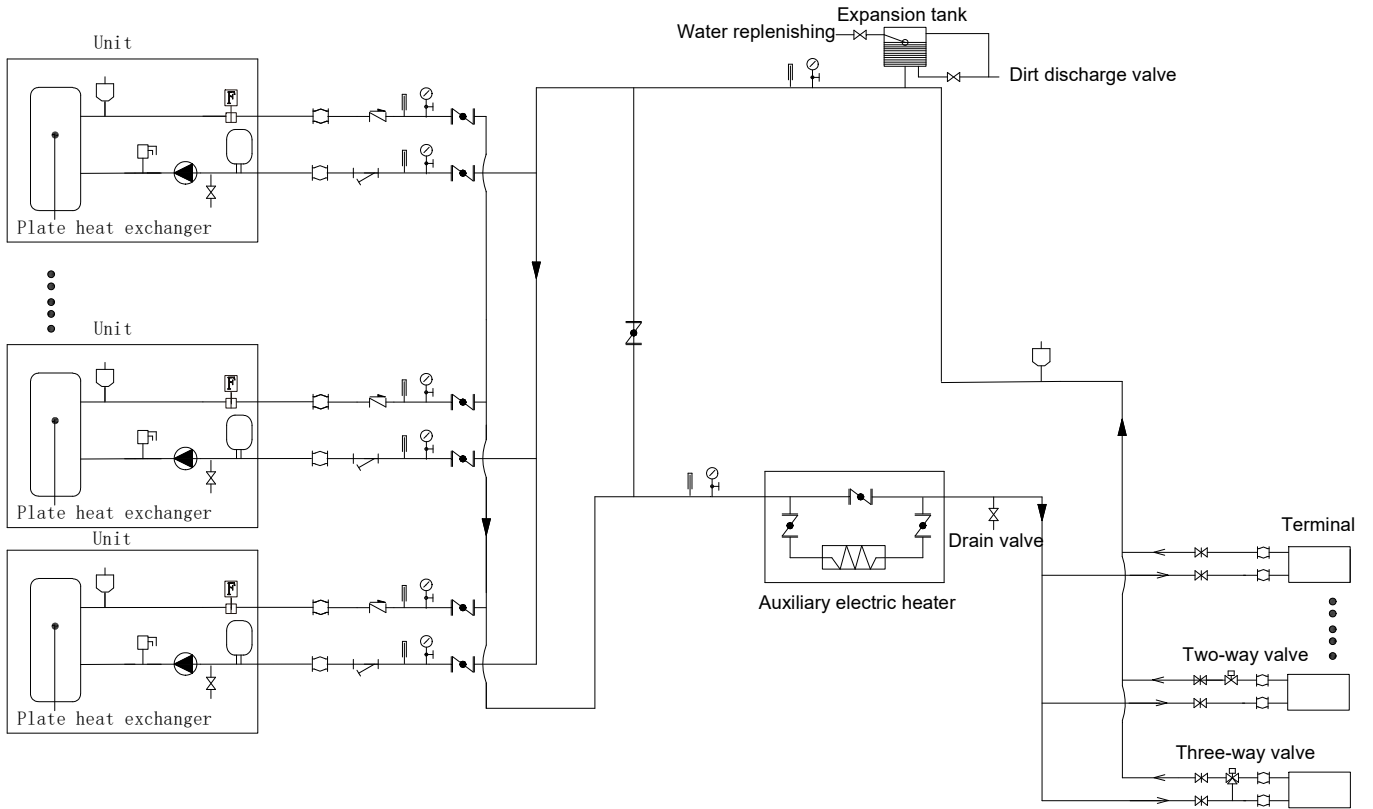

Water flow switch	Safety valve	Expansion tank	Drain valve	Atmospheric exhaust valve
Soft joint	Pump	Shut off valve	Y-filter	Solenoid three-way valve
Water pressure instrument	Check valve	Thermometer		

### 1.2.3 Space Heating Through Floor Heating Loops and Space Cooling Through Fan Coil Unit

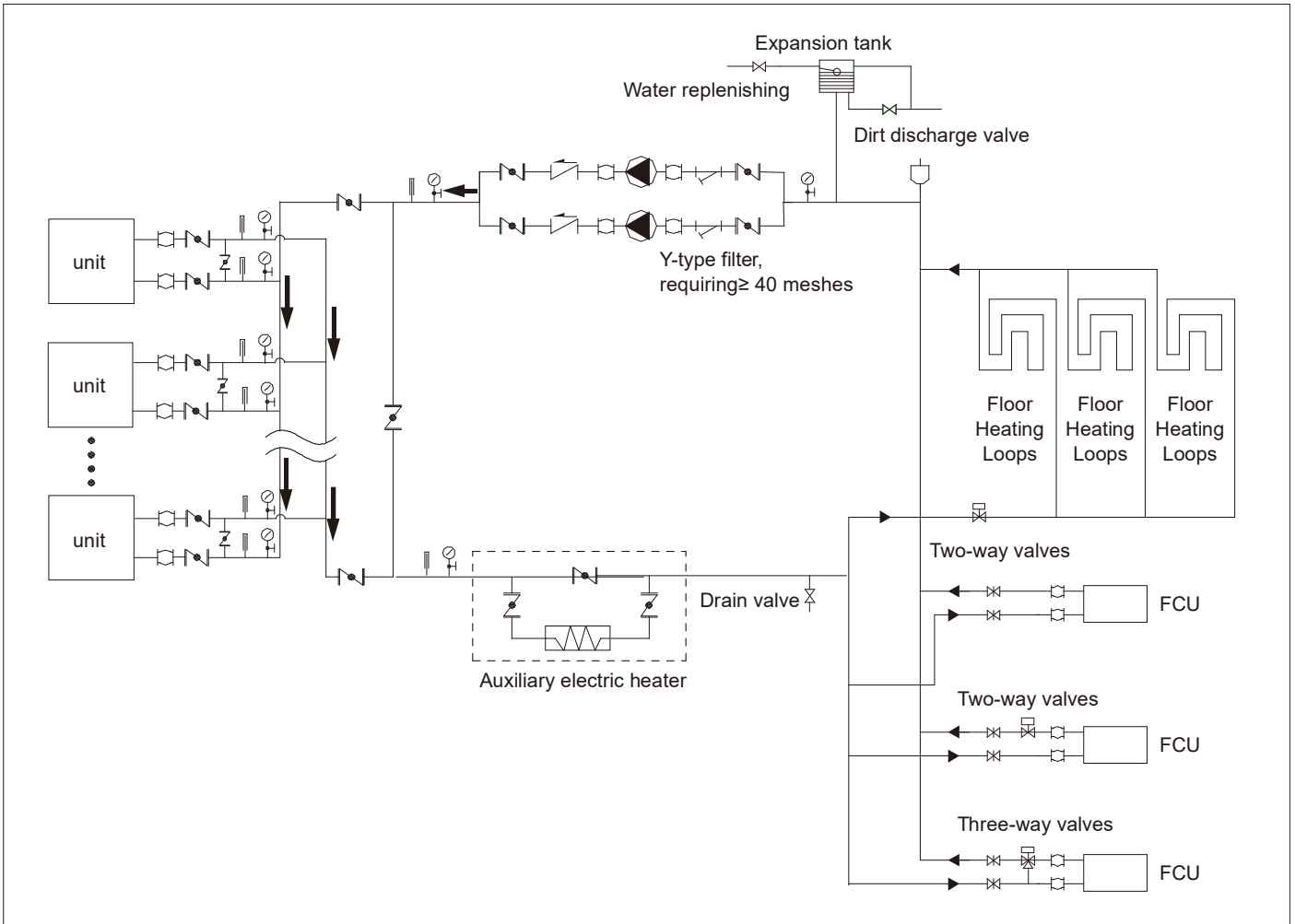









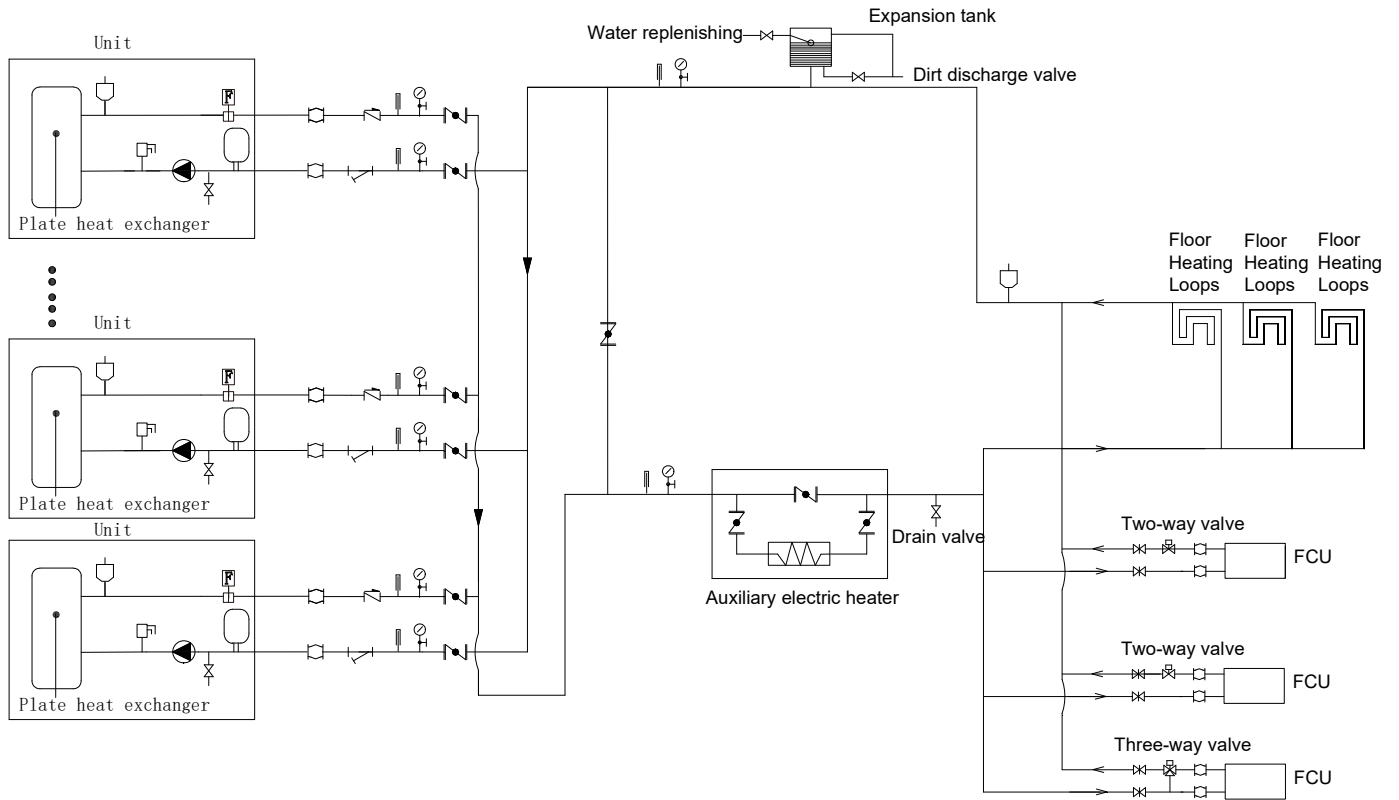





Legend				
Stop valve	Pressure gauge	Flexible joint	Gate valve	Automatic discharge valve
Y-shaped filter	Thermometer	Circulating pump	Check valve	

Note:

In space cooling mode, the 2-way valve on the floor heating branch circuit is closed to prevent cold water entering the floor heating loops.

## Machine with water pump



 Water flow switch	 Safety valve	 Expansion tank	 Drain valve	 Atmospheric exhaust valve
 Soft joint	 Pump	 Shut off valve	 Y-filter	 Solenoid three-way valve
 Water pressure instrument	 Check valve	 Thermometer		

## 2 Product lineup

Model	MUENR-75-H12T MUENR-75-H12T(K)	MUENR-90-H12T MUENR-90-H12T(K)	MUENR-140-H12T MUENR-140-H12T(K)	MUENR-180-H12T MUENR-180-H12T(K)
Power supply	380-415V/3Ph/50Hz	380-415V/3Ph/50Hz	380-415V/3Ph/50Hz	380-415V/3Ph/50Hz
Appearance				

## 4 System Design and Unit Selection

### 4.1 Selection Procedure

#### Step 1: Total heat load calculation

Calculate conditioned surface area  
Select the heat emitters (type, quantity, water temperature and heat load)

#### Step 2: System configuration

Decide whether to enable or disable auxiliary electric heater

#### Step 3: Selection of outdoor units

Determine required total heat load on outdoor units  
Set capacity safety factor  
Select power supply

Provisionally select MUENR-H12T/H12T(K) Series unit capacity<sup>1</sup> based on nominal capacity

Correct capacity of the outdoor units for the following items:  
Outdoor air temperature / Outdoor humidity / Water outlet temperature<sup>2</sup> /  
Altitude / Anti-freeze type

Is corrected MUENR-H12T/H12T(K) capacity  $\geq$  Required total heat load on outdoor units<sup>3</sup>

Yes

MUENR-H12T/H12T(K)  
system selection is complete

No

Select a larger model or enable  
auxiliary electric heater operation

#### Notes:

1. Up to 16 units (8 units for MUENR-180-H12T) can be connected together, giving a system cooling/heating capacity range from 75kW to 2240kW.
2. If the required water temperatures of the heat emitters are not all the same, the MUENR-H12T/H12T(K)'s outlet water temperature setting should be set at the highest of the heat emitter required water temperatures. If the water outlet design temperature falls between two temperatures listed in the outdoor unit's capacity table, calculate the corrected capacity by interpolation.
3. Select MUENR-H12T/H12T(K) which satisfies both total heating and cooling load requirements.

## 4.2 Modular Chiller Leaving Water Temperature (LWT) Selection

The recommended design LWT ranges for different types of heat emitter are:

- For floor heating: 30 to 35°C
- For fan coil units: 30 to 45°C
- For low temperature radiators: 40 to 50°C

## 4.3 Optimizing System Design

To get the most comfort with the lowest energy consumption with MUENR-H12T/H12T(K), it is important to take account of the following considerations:

- Choose heat emitters that allow the heat pump system to operate at as low a hot water temperature as possible whilst still providing sufficient heating.

## 4.4 Design of the buffer tank in the system

### 4.4.1 Selection of buffer tank

The role of the buffer water tank:

In cooling mode, it prevents frequent opening and stopping of the equipment, thus protecting it.

The buffer water tank serves different purposes depending on whether the system is in cooling or heating mode. In heating mode, it ensures system stability during defrosting and reduces the need for frequent start-stop of the unit under small load conditions.

Design calculation method:

#### a) Calculation of defrosting time under heating conditions

The most significant factor affecting the air source heat pump heating system is the defrosting of the winter unit. To ensure thermal stability, the main engine's defrosting time should be limited to 4 minutes during winter operation. Additionally, the water temperature before and after defrosting should not decrease by more than 3°C. The buffer tank's volume should be calculated based on the above data.

Heating conditions, minimum effective water capacity calculation:

$$M_H = [Q_h \times H_{min} \times T_H / (C \times \Delta T_H)] / \rho$$

Where:

$M_H$ : minimum water capacity of the system, m<sup>3</sup>;

$Q_h$ : rated heat production of the main engine, kW;

$H_{min}$ : coefficient of defrosting ability, %; generally take: 50%;

$\Delta T_H$ : Water temperature drop before and after defrosting, °C; Conventional units generally take 3°C;

$C$ : specific heat gain of water 4.18 kJ/(kg·°C);

$\rho$ : Density of water, 1000 kg/m<sup>3</sup>;

$T_H$ : defrosting time, S; generally take 240S

#### b) Cooling running time calculation method

During the cooling process, avoid frequently opening and stopping the equipment to protect it. Ensure that there is enough water to allow the equipment to run continuously for at least 5 minutes.

Refrigeration conditions, the minimum effective water capacity calculation:

$$M_C = [Q_C \times C_A \times C_{min} \times T_C / (C \times \Delta T_C)] / \rho$$

Where:

$M_c$ : minimum system water capacity, m<sup>3</sup>;

$Q_c$ : cooling rated capacity, kW;

CA: Capacity coefficient of small load condition: generally: 1.6.

$C_{min}$ : the minimum operating capacity ratio of the unit, %; Fixed frequency according to 100%; Frequency conversion unit according to 30%;

$\Delta TC$ : Control temperature range, °C; Factory default 4°C;

C: specific heat gain of water 4.18 kJ/(kg·°C);

$\rho$  : Density of water, 1000 kg/m<sup>3</sup>;

$T_c$ : cooling operation time, S, generally 300S;

C) Calculate the system capacity according to the cooling and heating conditions, and take the maximum value;

$$M = \text{MAX}(M_H, M_c)$$

Single cooling unit takes  $M_c$ , single heating unit takes  $M_H$ ;

d) The effective water capacity of a water system refers to its total capacity, including the main pipeline, water storage tank, and the normally open end of the two-way valve involved in circulation during operation.

$$M_2 = V \times L$$

Where:  $M_2$ : effective water capacity of water system, m<sup>3</sup>;

L: Total length of system pipeline, m;

V: Water capacity m<sup>3</sup>/m per meter pipe length of each model system pipeline.

e) Buffer tank volume refers to the minimum water capacity required to meet the normal operation of the unit:

$$V_{min} = M - M_2$$

$V_{min}$  - Minimum volume of buffer tank, m<sup>3</sup>.

#### 4.4.2 Empirical Estimation Method

For renovation projects where the system water capacity cannot be estimated, the volume of the buffer tank can be estimated empirically using the following formula:

$V_{min} = Q \times K$ . Here,  $V_{min}$  represents the minimum volume of the buffer tank in litres.

The comfort air conditioning requires 10 L/kW and the process air conditioning requires 15. The stability of the system water temperature increases with a higher K value.

The main mechanism for heat is measured in kW.

(3) Precautions for buffer tank selection:

a) The configuration of the buffer tank depends on the specific project instance. If the water system capacity is large or the end form is in the form of floor heating, the buffer tank should not be added. However, increasing the size of the buffer water tank has several advantages for the system's operation. It helps to avoid frequent opening and stopping of the main engine under small load conditions, prevents defrosting of the main engine, and ensures that there is enough water in the system to meet the unit defrosting requirements. This improves the comfort of the unit. Therefore, it is necessary to comprehensively consider various factors on the site from an investment perspective.

b) There are two methods to calculate the volume of the buffer tank. The results differ, with method 1 being more accurate as it is based on actual operation data analysis. Therefore, it is recommended to use method 1 for actual design and selection. Method 2 is an empirical estimate.

C) When using multiple units in parallel, it is recommended to base the calculation on the maximum capacity of the parallel unit.

# Part 2

## Engineering Data

<b>1 Specifications .....</b>	<b>15</b>
<b>2 Electrical Characteristics.....</b>	<b>17</b>
<b>3 Dimensions and Center of Gravity .....</b>	<b>18</b>
<b>4 Operating Limits.....</b>	<b>20</b>
<b>5 Capacity Tables.....</b>	<b>21</b>
<b>6 Performance Adjustment Factors .....</b>	<b>37</b>
<b>7 Hydronic Performance.....</b>	<b>39</b>
<b>8 Octave Band Levels .....</b>	<b>43</b>

# 1 Specifications

Model name			MUENR-75-H12T	MUENR-90-H12T	MUENR-140-H12T	MUENR-180-H12T	
Power supply		V/Ph/Hz	380~415/3/50	380~415/3/50	380~415/3/50	380~415/3/50	
Cooling <sup>1</sup>	Capacity	kW	70	82	130	164	
	Rated input	kW	26.8	27.8	50.5	56	
	EER			2.61	2.95	2.57	2.93
Heating <sup>2</sup>	Capacity	kW	75	90	138	180	
	Rated input	kW	23.7	28.1	44.5	57	
	COP			3.16	3.2	3.1	3.16
Air side heat exchanger	Type		Finned tube	Finned tube	Finned tube	Finned tube	
	Fan motor type		DC motor	DC motor	DC motor	DC motor	
	Fan motor output	W	920	920	1500	920	
	Fan motor quantity			2	2	2	4
	Air flow rate	m <sup>3</sup> /h	28500	35000	50000	70000	
Water side heat exchanger	Type		Plate	Plate	Plate	Plate	
	Volume	L	5.17	7.05	11.1	6.96×2	
	Rated water flow	m <sup>3</sup> /h	12.04	15	22.36	28.2	
	Water flow range	m <sup>3</sup> /h	8.0~15.5	10.2 ~ 18	15.6~28.5	20~36.1	
	Water pressure drop	kPa	65	75	65	96	
Refrigerant system	Refrigerant type		R32	R32	R32	R32	
	Refrigerant charge <sup>3</sup>	kg	9	16 (11.5+4.5)	15.5(11.5+4)	16 (5.5+10.5)*2	
	Throttle type		EXV	EXV	EXV	EXV	
Sound power level <sup>4</sup>		dB	86	83	92	92	
Sound pressure level(1m) <sup>5</sup>		dB(A)	69	65	73	72	
Net dimensions (W×H×D)		mm	2000×1775×960	2220×2315×1120	2220×2300×1120	2755×2415×2220	
Packed dimensions (W×H×D)		mm	2085×1890×1030	2250×2445×1180	2250×2425×1180	2810×2446×2245	
Net/Gross weight		kg	440/450	635/660	670/690	1400/1420	
Water pipe connections		mm	DN50	DN50	DN65	DN80	
Water pressure range		MPa	0.05 ~ 1.0	0.05 ~ 1.0	0.05 ~ 1.0	0.05 ~ 1.0	
Water flow switch action flow		m <sup>3</sup> /h	8	10	15.6	20	
Vent Valve max working pressure		Mpa	1	1	1	1	
Safety valve action pressure		Mpa	0.6	0.6	0.6	0.6	
Controller			KJRM-120H2/BMWK	KJRM-120H2/BMWK	KJRM-120H2/BMWK	KJRM-120H2/BMWK	
Operating temperature	Cooling	°C	-10 to 48	-10 to 48	-10 to 48	-10 to 48	
	Heating	°C	-20 to 43	-20 to 43	-20 to 43	-20 to 43	
Water outlet temperature	Cooling	°C	0 to 20	0 to 20	0 to 20	0 to 20	
	Heating	°C	25 to 54	25 to 54	25 to 54	25 to 54	

Model name		MUENR-75-H12T(K)	MUENR-90-H12T(K)	MUENR-140-H12T(K)	MUENR-180-H12T(K)	
Power supply		V/Ph/Hz	380~415/3/50	380~415/3/50	380~415/3/50	380~415/3/50
Cooling <sup>1</sup>	Capacity	kW	69.7	82	129.5	163.0
	Rated input	kW	27.3	28.3	51.4	57.7
	EER		2.55	2.90	2.52	2.82
Heating <sup>2</sup>	Capacity	kW	75.4	90	138.6	181.2
	Rated input	kW	24.3	29	45.6	59.1
	COP		3.10	3.10	3.04	3.07
Air side heat exchanger	Type		Finned tube	Finned tube	Finned tube	Finned tube
	Fan motor type		DC motor	DC motor	DC motor	DC motor
	Fan motor output	W	920	920	1500	920
	Fan motor quantity		2	2	2	4
	Air flow rate	m <sup>3</sup> /h	28500	35000	50000	70000
Water side heat exchanger	Type		Plate	Plate	Plate	Plate
	Volume	L	5.17	7.05	11.1	6.96×2
	Rated water flow	m <sup>3</sup> /h	12.04	15	22.36	28.2
	Water flow range	m <sup>3</sup> /h	8.0~15.5	10.2 ~ 18	15.6~28.5	20~36.1
Refrigerant system	Refrigerant type		R32	R32	R32	R32
	Refrigerant charge <sup>3</sup>	kg	9	16 (11.5+4.5)	15.5(11.5+4)	16 (5.5+10.5)*2
	Throttle type		EXV	EXV	EXV	EXV
Pump	Power supply	V/Ph/Hz	380~415/3/50	380~415/3/50	380~415/3/50	380~415/3/50
	Rated input	kW	1.5	1.5	2.2	1.5
	Rated current	A	3.15	3.15	4.45	3.15
	Rate of flow	m <sup>3</sup> /h	10	10	22	10
	Head of delivery	m	27.1	40.5	16.2	40.5
	Quantity	/	1	1	1	2
Expansion tank	Volume	L	12	12	24	12*2
	Precharge pressure	Mpa	0.15	0.15	0.15	0.15
	Test pressure	Mpa	1.0	1.0	1.0	1.0
Sound power level <sup>4</sup>	dB	86	83	93	92	
Sound pressure level(1m) <sup>5</sup>	dB(A)	69	65	74	72	
Net dimensions (W×H×D)	mm	2000×1775×960	2220×2315×1120	2220×2300×1120	2755×2415×2220	
Packed dimensions (W×H×D)	mm	2085×1890×1030	2250×2445×1180	2250×2425×1180	2810×2446×2245	
Net/Gross weight	kg	475/485	686/700	746/776	1500/1520	
Water pipe connections	mm	DN50	DN50	DN65	DN80	
Water pressure range	MPa	0.05 ~ 1.0	0.05 ~ 1.0	0.05 ~ 1.0	0.05 ~ 1.0	
Water flow switch action flow	m <sup>3</sup> /h	8	10	15.6	20	
Vent Valve max working pressure	Mpa	1	1	1	1	
Safety valve action pressure	Mpa	0.6	0.6	0.6	0.6	
Controller		KJRM-120H2/BMWK	KJRM-120H2/BMWK	KJRM-120H2/BMWK	KJRM-120H2/BMWK	
Operating temperature	Cooling	°C	-10 to 48	-10 to 48	-10 to 48	-10 to 48
	Heating	°C	-20 to 43	-20 to 43	-20 to 43	-20 to 43
Water outlet temperature	Cooling	°C	0 to 20	0 to 20	0 to 20	0 to 20
	Heating	°C	25 to 54	25 to 54	25 to 54	25 to 54

Notes:

1. Outdoor ambient temperature 35°C DB. EWT 12°C, LWT 7°C;
2. Outdoor ambient temperature 7°C DB/6°C WB. EWT 40°C, LWT 45°C;
3. The total amount of refrigerant for unit which capacity above 90kW include (factory charged + field charged).
4. Test standard: EN12102-1. Outdoor ambient temperature 35°C DB. EWT 12°C, LWT 7°C
5. Outdoor ambient temperature 35°C DB. EWT 12°C, LWT 7°C

Sound pressure level is the test average measured in a semi-anechoic chamber. The test position is 1m right in front of the unit for four sides and  $(1+H)/2$ m (where H is the height of the unit) above the floor. During in-situ operation, sound pressure levels may be higher as a result of ambient noise.

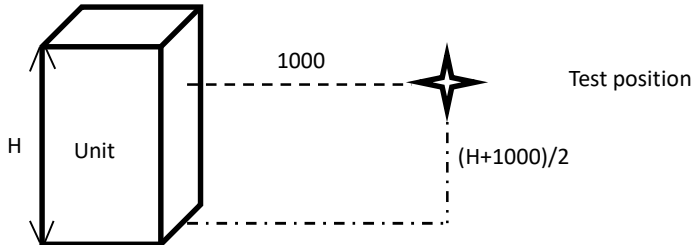

6. Capacity and efficiency data calculated in accordance with EN14511; EN14825
7. Seasonal space heating energy efficiency class tested in average climate conditions.
8. Antifreeze liquid is needed when water outlet temperature is less than 5°C. Customization is required to achieve water outlet temperature 0°C.

## 2 Electrical Characteristics

System	Outdoor unit				Power current		Compressor		Fan	
	Voltage	Hz	Min.	Max.	MCA	MOP	MSC	RLA	kW	FLA
	(V)		(V)	(V)	(A)	(A)	(A)	(A)		(A)
MUENR-75-H12T	380-415	50	342	456	46	54	-	34.09	0.92	4.4
MUENR-75-H12T(K)	380-415	50	342	456	49	57		34.09	0.92	4.4
MUENR-90-H12T	380-415	50	342	456	60	70	-	30.86	0.92	5.2
MUENR-90-H12T(K)	380-415	50	342	456	63	73		30.86	0.92	5.2
MUENR-140-H12T	380-415	50	342	456	90	106	-	34.09	1.5	8
MUENR-140-H12T(K)	380-415	50	342	456	94	110		34.09	1.5	8
MUENR-180-H12T	380-415	50	342	456	120	141	-	30.86	0.92	5.2
MUENR-180-H12T(K)	380-415	50	342	456	126	147		30.86	0.92	5.2

Note:

MCA: Min. Circuit Amps. (A)

MOP: Maximum overcurrent protector (A)

MSC : Max. Starting Amps. (A)

RLA: In nominal cooling or heating test condition, the input Amps of compressor where MAX. Hz can operate Rated Load Amps. (A)

KW: Rated Motor Output

FLA: Full Load Amps. (A)

### 3 Dimensions and Center of Gravity

MUENR-75-H12T, MUENR-75-H12T(K)

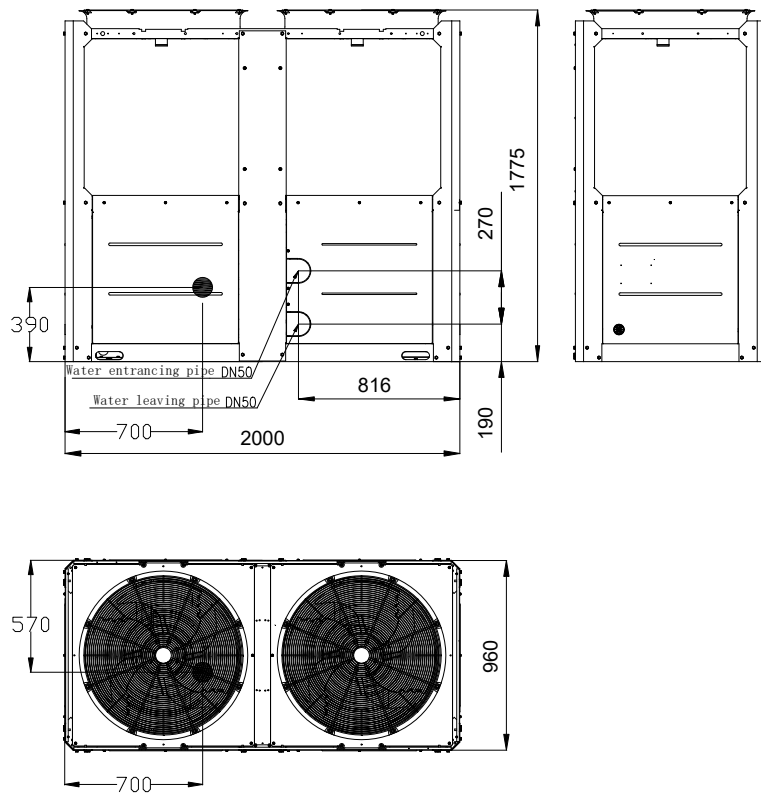

MUENR-90-H12T, MUENR-90-H12T(K)

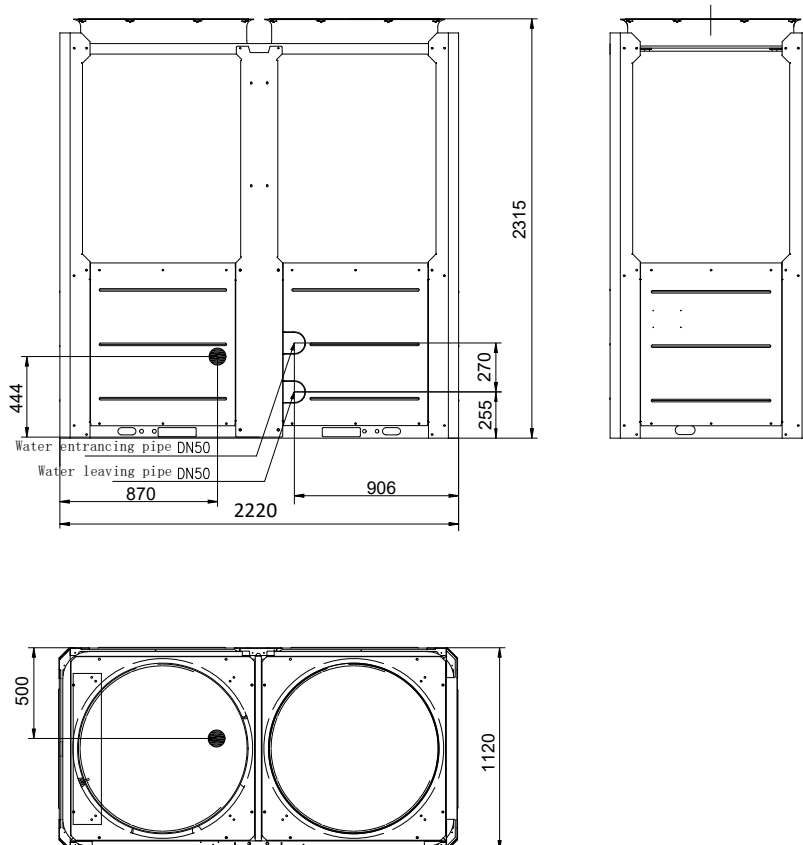

MUENR-140-H12T, MUENR-140-H12T(K)

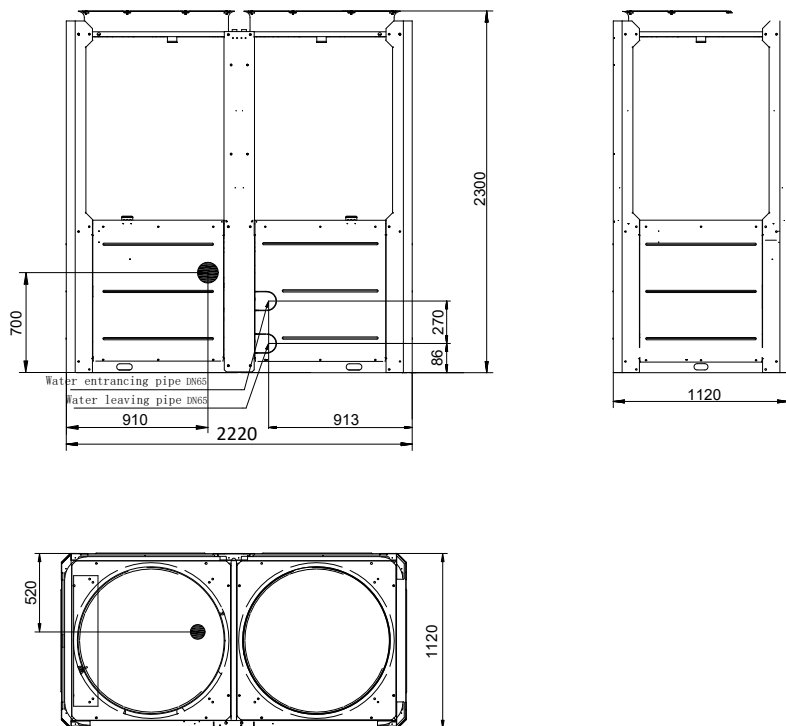

MUENR-180-H12T, MUENR-180-H12T(K)

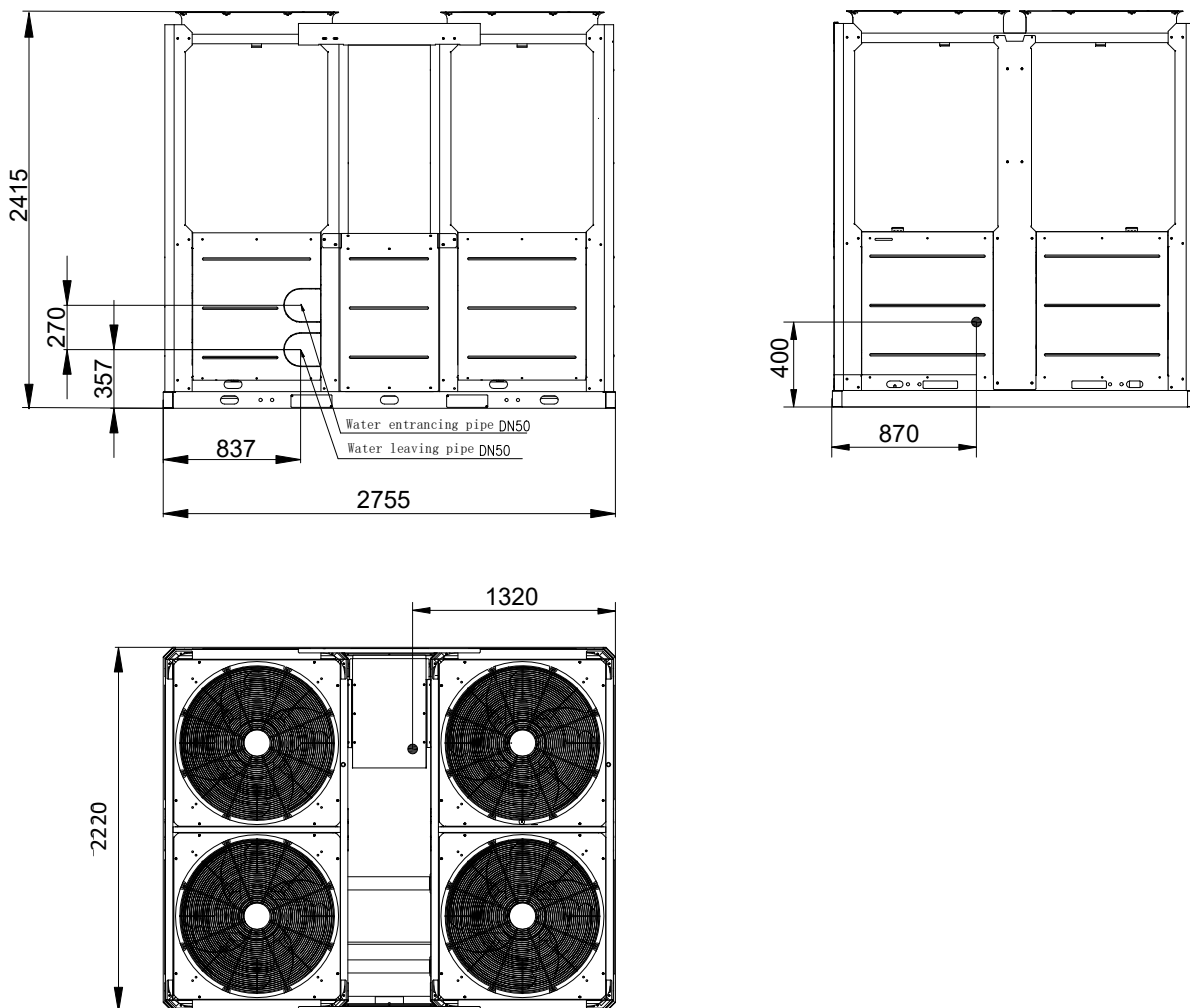

## 4 Operating Limits

T4: Ambient temperature(°C)

Two: Leaving water temperature(°C)

### 4.1 Cooling operating range

MUENR-75-H12T, MUENR-90-H12T, MUENR-140-H12T, MUENR-180-H12T MUENR-75-H12T(K),  
MUENR-90-H12T(K), MUENR-140-H12T(K), MUENR-180-H12T(K)

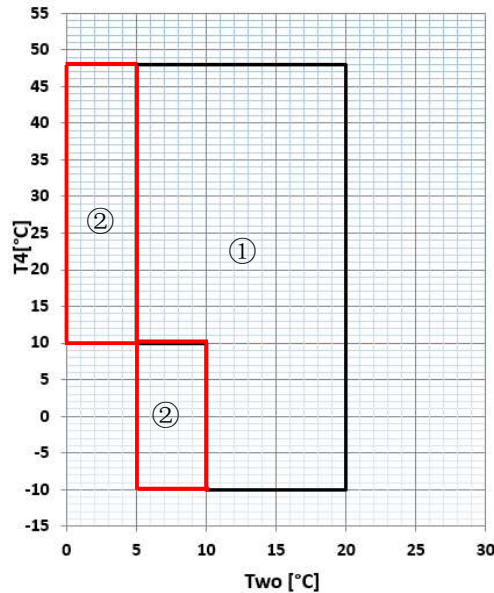

Notes:

- ① Normal mode
- ② Low leaving water temperature mode

Low leaving water temperature mode can be set through wired controller, please refer to the Operation Manual for details. If low leaving water temperature function is effective, the operation range will extend to the red frame above. When the set temperature is less than 5°C, antifreeze liquid (concentration above 15%) should be added in the water system, otherwise the unit will be damaged.

- ③ Customization is required to achieve water outlet temperature 0°C.

### 4.2 Heating operating range

MUENR-75-H12T, MUENR-75-H12T  
(K)MUENR-140-H12T, MUENR-140-H12T

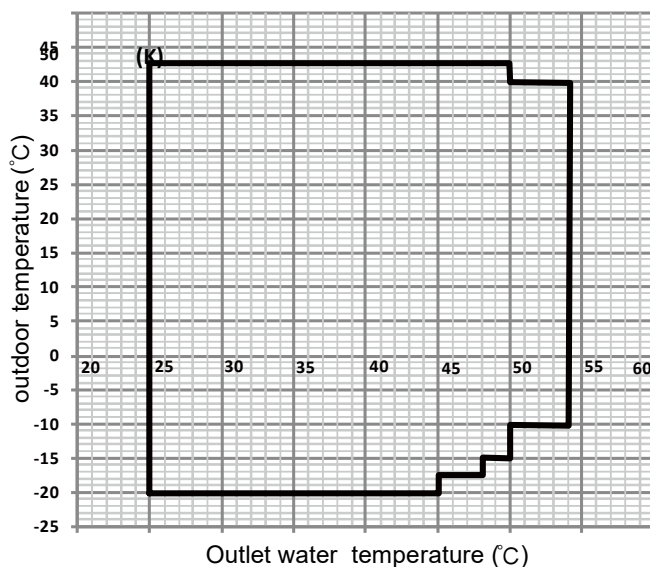

MUENR-90-H12T, MUENR-90-H12T  
(K)MUENR-180-H12T, MUENR-180-H12T

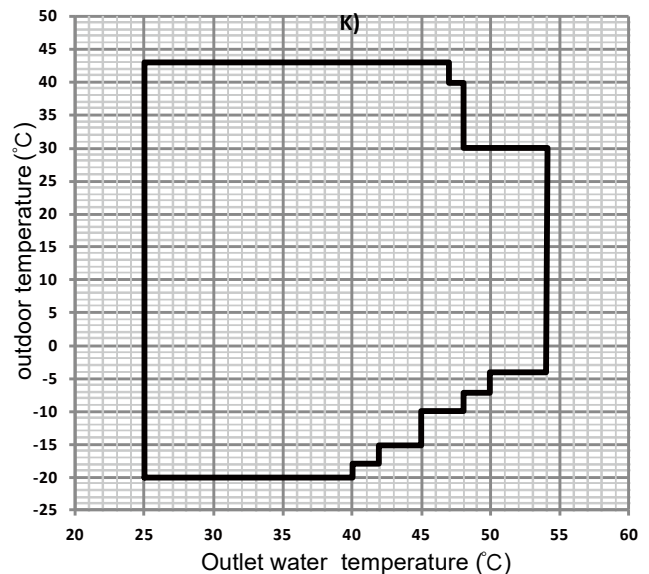

## 5 Capacity Tables

### 5.1 Heating Capacity Tables

#### MUENR-75-H12T

LWT	DB																	
	-20			-18			-15			-10			-5			0		
	HC	PI	COP	HC	PI	COP	HC	PI	COP	HC	PI	COP	HC	PI	COP	HC	PI	COP
25	46.2	19.8	2.3	50.1	18.6	2.7	53.3	19.4	2.7	56.7	20.3	2.8	63.8	21.7	2.9	70.8	22.5	3.1
30	43.8	21.3	2.1	49.5	19.3	2.6	52.7	20.1	2.6	56.1	20.9	2.7	62.6	22.2	2.8	69.2	23.5	2.9
35	42.7	22.9	1.9	45.4	20.1	2.3	48.3	20.9	2.3	51.4	21.8	2.4	57.5	23.1	2.5	63.5	23.0	2.8
40	39.2	23.3	1.7	45.0	24.5	1.8	47.9	25.2	1.9	51.0	26.0	2.0	57.6	26.4	2.2	64.3	25.6	2.5
45	38.7	27.3	1.4	42.3	26.1	1.6	46.8	27.8	1.7	49.8	28.4	1.8	57.2	29.7	1.9	64.7	28.3	2.3
48				32.6	25.2	1.3	40.6	28.1	1.4	43.2	27.1	1.6	50.1	27.9	1.8	57.0	26.9	2.1
50							35.7	24.9	1.4	40.0	26.3	1.5	47.4	28.1	1.7	54.7	27.8	2.0
54										31.7	21.6	1.5	40.3	24.9	1.6	53.7	28.3	1.9

LWT	DB																	
	5			7			10			15			20			25		
	HC	PI	COP	HC	PI	COP	HC	PI	COP	HC	PI	COP	HC	PI	COP	HC	PI	COP
25	75.0	22.7	3.3	82.2	23.2	3.5	83.6	20.8	4.0	96.9	23.2	4.2	100.3	22.8	4.4	106.2	22.8	4.6
30	73.2	23.3	3.2	80.7	22.9	3.5	82.2	21.5	3.8	91.4	22.5	4.1	96.5	22.6	4.3	104.7	23.1	4.5
35	67.4	22.4	3.0	74.7	21.3	3.5	76.9	21.0	3.7	88.2	22.4	3.9	93.4	22.5	4.1	102.5	22.8	4.5
40	68.5	24.1	2.8	74.9	23.3	3.2	77.8	22.9	3.4	85.7	23.5	3.7	87.4	22.0	4.0	96.1	22.4	4.3
45	69.1	25.7	2.7	75.0	23.7	3.2	76.2	23.5	3.3	79.0	23.1	3.4	85.2	23.0	3.7	93.4	23.5	4.0
48	61.1	23.2	2.6	66.2	23.0	2.9	70.2	23.2	3.0	51.0	15.6	3.3	79.9	22.0	3.6	86.2	22.7	3.8
50	59.8	23.3	2.6	65.0	23.1	2.8	68.0	22.9	3.0	38.4	12.3	3.1	76.2	21.5	3.6	79.4	21.5	3.7
54	58.7	23.7	2.5	63.8	23.0	2.8	68.0	23.2	2.9	18.6	6.2	3.0	22.6	7.3	3.1	23.5	7.5	3.2

LWT	DB											
	30			35			40			43		
	HC	PI	COP	HC	PI	COP	HC	PI	COP	HC	PI	COP
25	113.6	21.6	5.2	114.4	19.4	5.9	115.9	18.6	6.2	114.3	17.7	6.3
30	115.4	23.0	5.0	118.6	20.8	5.7	123.3	21.1	5.9	117.1	19.6	6.0
35	114.2	23.7	4.8	121.5	22.9	5.3	126.2	23.3	5.4	118.6	21.0	5.6
40	105.7	23.9	4.4	112.5	22.5	5.0	117.9	23.0	5.1	110.3	20.8	5.3
45	95.4	22.6	4.2	102.8	21.6	4.8	105.4	21.7	4.9	99.3	19.8	5.0
48	70.8	17.5	4.0	74.7	16.5	4.5	77.8	16.8	4.6	71.7	15.1	4.8
50	56.7	14.4	3.9	59.1	14.0	4.2	63.4	14.6	4.4	57.8	12.7	4.6
54	25.4	7.8	3.3	28.5	8.4	3.4	40.2	11.5	3.5			

**Abbreviations:**

HC: Total heating capacity (kW)

PI: Power input (kW)

LWT: Leaving water temperature (°C)

DB: Dry-bulb temperature for outdoor air temperature (°C)

Performance specifications measured with water pump operating at rated water flow rate.

**MUENR-75-H12T(K)**

LWT	DB																	
	-20			-18			-15			-10			-5			0		
	HC	PI	COP	HC	PI	COP	HC	PI	COP	HC	PI	COP	HC	PI	COP	HC	PI	COP
25	46.2	21.3	2.2	50.1	20.1	2.5	53.3	20.9	2.5	56.7	21.8	2.6	63.8	23.2	2.7	70.8	24.0	2.9
30	43.8	22.8	1.9	49.5	20.8	2.4	52.7	21.6	2.4	56.1	22.4	2.5	62.6	23.7	2.6	69.2	25.0	2.8
35	42.7	24.4	1.8	45.4	21.6	2.1	48.3	22.4	2.2	51.4	23.3	2.2	57.5	24.6	2.3	63.5	24.5	2.6
40	39.2	24.8	1.6	45.0	26.0	1.7	47.9	26.7	1.8	51.0	27.5	1.9	57.6	27.9	2.1	64.3	27.1	2.4
45	38.7	28.8	1.3	42.3	27.6	1.5	46.8	29.3	1.6	49.8	29.9	1.7	57.2	31.2	1.8	64.7	29.8	2.2
48	/	/	/	32.6	26.7	1.2	40.6	29.6	1.4	43.2	28.6	1.5	50.1	29.4	1.7	57.0	28.4	2.0
50	/	/	/	/	/	/	35.7	26.4	1.4	40.0	27.8	1.4	47.4	29.6	1.6	54.7	29.3	1.9
54	/	/	/	/	/	/	/	/	/	31.7	23.1	1.4	40.3	26.4	1.5	53.7	29.8	1.8

LWT	DB																	
	5			7			10			15			20			25		
	HC	PI	COP	HC	PI	COP	HC	PI	COP	HC	PI	COP	HC	PI	COP	HC	PI	COP
25	75.0	24.2	3.1	82.2	24.7	3.3	83.6	22.3	3.7	96.9	24.7	3.9	100.3	24.3	4.1	106.2	24.3	4.4
30	73.2	24.8	3.0	80.7	24.4	3.3	82.2	23.0	3.6	91.4	24.0	3.8	96.5	24.1	4.0	104.7	24.6	4.3
35	67.4	23.9	2.8	74.7	22.8	3.3	76.9	22.5	3.4	88.2	23.9	3.7	93.4	24.0	3.9	102.5	24.3	4.2
40	68.5	25.6	2.7	74.9	24.8	3.0	77.8	24.4	3.2	85.7	25.0	3.4	87.4	23.5	3.7	96.1	23.9	4.0
45	69.1	27.2	2.5	75.0	25.2	3.0	76.2	25.0	3.1	79.0	24.6	3.2	85.2	24.5	3.5	93.4	25.0	3.7
48	61.1	24.7	2.5	66.2	24.5	2.7	70.2	24.7	2.8	51.0	17.1	3.0	79.9	23.5	3.4	86.2	24.2	3.6
50	59.8	24.8	2.4	65.0	24.6	2.6	68.0	24.4	2.8	38.4	13.8	2.8	76.2	23.0	3.3	79.4	23.0	3.4
54	58.7	25.2	2.3	63.8	24.5	2.6	68.0	24.7	2.8	18.6	7.7	2.4	22.6	8.8	2.6	23.5	9.0	2.6

LWT	DB											
	30			35			40			43		
	HC	PI	COP	HC	PI	COP	HC	PI	COP	HC	PI	COP
25	113.6	23.1	4.9	114.4	20.9	5.5	115.9	20.1	5.8	114.3	19.2	6.0
30	115.4	24.5	4.7	118.6	22.3	5.3	123.3	22.6	5.5	117.1	21.1	5.5
35	114.2	25.2	4.5	121.5	24.4	5.0	126.2	24.8	5.1	118.6	22.5	5.3
40	105.7	25.4	4.2	112.5	24.0	4.7	117.9	24.5	4.8	110.3	22.3	5.0
45	95.4	24.1	4.0	102.8	23.1	4.4	105.4	23.2	4.5	99.3	21.3	4.7
48	70.8	19.0	3.7	74.7	18.0	4.1	77.8	18.3	4.2	71.7	16.6	4.3
50	56.7	15.9	3.6	59.1	15.5	3.8	63.4	16.1	3.9	57.8	14.2	4.1
54	25.4	9.3	2.7	28.5	9.9	2.9	40.2	13.0	3.1	/	/	/

Abbreviations:

HC: Total heating capacity (kW)

PI: Power input (kW)

LWT: Leaving water temperature (°C)

DB: Dry-bulb temperature for outdoor air temperature (°C)

Performance specifications measured with water pump operating at rated water flow rate.

**MUENR-90-H12T**

LWT	DB																	
	-20			-18			-15			-10			-7			-4		
	HC	PI	COP	HC	PI	COP	HC	PI	COP	HC	PI	COP	HC	PI	COP	HC	PI	COP
25	44.7	21.1	2.1	49.6	21.8	2.3	56.8	22.8	2.5	67.4	23.2	2.9	73.7	23.5	3.1	79.1	24.3	3.3
30	43.9	21.7	2.0	48.7	22.4	2.2	55.8	23.4	2.4	66.2	23.9	2.8	72.4	24.2	3.0	77.7	25.0	3.1
35	42.7	24.8	1.7	47.0	25.3	1.9	53.6	25.9	2.1	63.9	26.1	2.5	70.2	26.2	2.7	75.5	26.3	2.9
40	39.7	26.6	1.5	44.2	27.0	1.6	51.0	27.6	1.8	61.6	28.2	2.2	68.0	28.6	2.4	73.7	28.7	2.6
42				42.4	26.7	1.6	48.9	27.3	1.8	59.9	28.6	2.1	66.5	29.4	2.3	72.2	29.5	2.4
45							45.8	26.9	1.7	57.2	29.2	2.0	64.1	30.6	2.1	69.9	30.8	2.3
47										50.6	27.1	1.9	56.6	28.4	2.0	63.6	29.3	2.2
48										48.6	27.7	1.8	54.5	29.0	1.9	61.2	29.9	2.0
50													48.0	28.0	1.7	55.3	29.3	1.9
54																47.5	29.6	1.6

LWT	DB																	
	2			7			15			20			25			30		
	HC	PI	COP	HC	PI	COP	HC	PI	COP	HC	PI	COP	HC	PI	COP	HC	PI	COP
25	89.9	25.9	3.5	102.0	23.8	4.3	104.8	23.1	4.5	104.9	21.7	4.8	102.8	20.0	5.2	100.0	17.6	5.7
30	88.3	26.6	3.3	101.4	24.5	4.1	103.9	23.7	4.4	104.0	22.3	4.7	101.9	20.5	5.0	99.2	18.1	5.5
35	86.3	26.4	3.3	100.2	26.4	3.8	102.4	24.9	4.1	102.3	23.5	4.3	100.2	20.7	4.8	96.0	18.3	5.2
40	84.9	28.8	2.9	95.7	27.0	3.5	99.1	25.8	3.8	99.6	24.5	4.1	99.3	21.5	4.6	94.6	18.7	5.1
42	83.5	29.8	2.8	92.8	27.5	3.4	98.5	26.8	3.7	98.9	25.0	4.0	98.3	21.8	4.5	90.7	18.8	4.8
45	81.5	31.3	2.6	90.0	28.1	3.2	97.7	28.2	3.5	98.2	25.5	3.9	96.8	22.3	4.3	84.9	18.8	4.5
47	77.6	31.1	2.5	86.5	31.2	2.8	93.5	27.1	3.5	90.1	22.8	3.9	83.7	19.4	4.3	74.6	17.4	4.3
48	74.6	31.8	2.3	83.2	31.9	2.6	89.9	27.6	3.3	86.6	23.3	3.7	80.5	19.8	4.1	71.8	17.8	4.0
50	70.0	32.1	2.2	78.3	32.2	2.4	84.7	27.2	3.1	79.1	22.2	3.6	75.6	19.2	3.9	63.0	17.1	3.7
54	59.9	33.3	1.8	67.0	34.0	2.0	73.9	27.0	2.7	70.2	21.2	3.3	58.9	15.7	3.8	47.0	14.4	3.3

LWT	DB								
	35			40			43		
	HC	PI	COP	HC	PI	COP	HC	PI	COP
25	93.6	15.0	6.3	89.6	13.6	6.6	88.8	13.5	6.6
30	92.8	15.4	6.0	88.9	14.0	6.3	88.0	13.8	6.4
35	89.0	16.7	5.3	80.0	13.3	6.0	78.6	12.4	6.4
40	85.0	16.0	5.3	71.4	11.4	6.3	70.1	10.7	6.5
42	81.7	16.0	5.1	69.2	11.8	5.9	67.8	11.3	6.0
45	76.8	16.2	4.7	66.0	12.4	5.3	64.3	12.2	5.3
47	67.9	15.0	4.5	57.7	11.6	5.0	56.0	11.4	4.9
48	65.3	15.3	4.3	55.5	11.8	4.7			
50									
54									

Abbreviations:

HC: Total heating capacity (kW)

PI: Power input (kW)

LWT: Leaving water temperature (°C)

DB: Dry-bulb temperature for outdoor air temperature (°C)

Performance specifications measured with water pump operating at rated water flow rate.

**MUENR-90-H12T(K)**

LWT	DB																	
	-20			-18			-15			-10			-7			-4		
	HC	PI	COP	HC	PI	COP	HC	PI	COP	HC	PI	COP	HC	PI	COP	HC	PI	COP
25	44.6	23.0	1.9	49.7	23.4	2.1	56.6	24.4	2.3	68.0	25.0	2.7	73.7	25.0	2.9	79.1	25.3	3.1
30	44.4	23.2	1.9	48.9	23.6	2.1	55.6	25.4	2.2	66.3	25.8	2.6	73.0	25.5	2.9	78.1	26.1	3.0
35	42.3	26.4	1.6	46.9	26.7	1.8	53.8	27.3	2.0	64.0	27.3	2.3	70.0	27.7	2.5	76.1	27.5	2.8
40	39.7	28.4	1.4	44.7	28.6	1.6	51.3	29.4	1.7	61.7	30.1	2.0	68.5	29.9	2.3	73.3	30.1	2.4
42				42.6	27.9	1.5	48.5	29.0	1.7	59.7	30.4	2.0	66.6	31.3	2.1	72.2	31.1	2.3
45							46.1	28.2	1.6	57.1	30.9	1.8	64.5	32.5	2.0	69.8	32.1	2.2
47										50.3	28.6	1.8	56.4	29.9	1.9	63.6	30.6	2.1
48										48.9	29.2	1.7	54.7	30.5	1.8	61.8	31.3	2.0
50													48.5	29.8	1.6	55.5	30.6	1.8
54																47.3	31.0	1.5

LWT	DB																	
	2			7			15			20			25			30		
	HC	PI	COP	HC	PI	COP	HC	PI	COP	HC	PI	COP	HC	PI	COP	HC	PI	COP
25	89.9	27.6	3.3	94.7	23.8	4.0	105.0	24.9	4.2	104.8	23.6	4.4	102.9	21.9	4.7	100.4	19.6	5.1
30	88.1	28.0	3.1	94.0	24.1	3.9	103.6	25.4	4.1	104.5	23.9	4.4	102.4	21.6	4.7	98.9	19.8	5.0
35	86.6	27.7	3.1	91.5	24.8	3.7	102.6	26.1	3.9	102.2	25.0	4.1	100.2	21.9	4.6	95.6	19.9	4.8
40	84.7	30.7	2.8	91.3	27.3	3.3	98.8	27.7	3.6	99.5	26.4	3.8	99.6	22.7	4.4	94.4	20.7	4.6
42	84.1	30.8	2.7	92.7	28.5	3.3	98.8	28.1	3.5	99.2	26.7	3.7	98.3	23.7	4.2	90.7	20.0	4.5
45	82.1	32.8	2.5	90.0	29.0	3.1	98.2	29.7	3.3	98.1	26.8	3.7	96.4	23.8	4.1	84.8	19.8	4.3
47	76.4	32.8	2.3	86.3	32.6	2.6	92.7	28.5	3.3	89.5	24.7	3.6	83.4	21.3	3.9	74.3	19.0	3.9
48	74.2	33.4	2.2	83.8	33.3	2.5	90.0	29.0	3.1	86.9	25.2	3.5	81.0	21.7	3.7	72.2	19.4	3.7
50	70.5	33.4	2.1	78.1	33.8	2.3	85.0	29.0	2.9	79.6	23.2	3.4	76.0	20.5	3.7	62.7	19.1	3.3
54	60.1	34.5	1.7	67.3	35.2	1.9	73.7	29.0	2.5	70.8	23.1	3.1	58.9	17.3	3.4	47.3	15.3	3.1

LWT	DB								
	35			40			43		
	HC	PI	COP	HC	PI	COP	HC	PI	COP
25	94.2	16.2	5.8	90.2	15.2	5.9	89.2	15.2	5.9
30	92.5	16.8	5.5	89.0	15.5	5.7	88.1	15.2	5.8
35	89.1	18.0	5.0	80.1	15.2	5.3	79.0	14.1	5.6
40	85.5	17.9	4.8	71.3	12.4	5.7	69.8	12.1	5.8
42	82.3	17.1	4.8	68.9	13.0	5.3	68.3	12.9	5.3
45	76.9	18.0	4.3	65.7	14.3	4.6	63.9	13.2	4.8
47	67.6	17.3	3.9	58.2	13.8	4.2	56.4	12.8	4.4
48	65.7	17.6	3.7	55.8	14.3	3.9			
50									
54									

Abbreviations:

HC: Total heating capacity (kW)

PI: Power input (kW)

LWT: Leaving water temperature (°C)

DB: Dry-bulb temperature for outdoor air temperature (°C)

Performance specifications measured with water pump operating at rated water flow rate..

**MUENR-140-H12T**

LWT	DB																	
	-20			-18			-15			-10			-5			0		
	HC	PI	COP	HC	PI	COP	HC	PI	COP	HC	PI	COP	HC	PI	COP	HC	PI	COP
25	89.7	40.3	2.2	98.0	39.8	2.5	104.6	41.5	2.5	109.8	40.6	2.7	124.3	45.0	2.8	137.0	46.9	2.9
30	82.0	38.3	2.1	93.2	39.0	2.4	98.4	41.6	2.4	105.2	41.4	2.5	117.9	45.2	2.6	129.1	47.3	2.7
35	83.2	42.7	2.0	89.4	40.8	2.2	94.4	43.0	2.2	100.2	42.5	2.4	112.8	46.9	2.4	124.4	49.0	2.5
40	66.2	40.1	1.7	77.1	39.9	1.9	89.7	43.6	2.1	94.6	42.8	2.2	107.4	47.1	2.3	119.8	51.0	2.3
45	67.1	62.7	1.1	75.9	46.2	1.6	86.8	46.4	1.9	91.7	45.6	2.0	105.9	51.4	2.1	119.1	55.2	2.2
48	/	/	/	64.6	41.9	1.5	80.7	44.6	1.8	85.4	43.9	1.9	99.3	50.2	2.0	113.6	55.4	2.0
50	/	/	/	/	/	/	68.4	40.1	1.7	77.0	42.1	1.8	90.8	47.7	1.9	105.2	54.3	1.9
54	/	/	/	/	/	/	/	/	/	35.8	22.0	1.6	45.6	27.0	1.7	60.5	35.1	1.7

LWT	DB																	
	5			7			10			15			20			25		
	HC	PI	COP	HC	PI	COP	HC	PI	COP	HC	PI	COP	HC	PI	COP	HC	PI	COP
25	146.4	43.3	3.4	158.9	42.4	3.7	169.7	43.1	3.9	180.1	45.1	4.0	196.8	48.1	4.1	213.6	51.5	4.2
30	137.5	43.6	3.2	150.6	43.3	3.5	166.2	44.3	3.8	178.3	47.2	3.8	188.4	48.9	3.9	198.5	50.9	3.9
35	131.5	43.7	3.0	138.5	42.1	3.3	161.7	45.0	3.6	172.0	47.1	3.7	180.7	48.3	3.7	186.2	48.4	3.9
40	127.8	46.3	2.8	138.8	44.7	3.1	158.9	46.5	3.4	166.0	47.8	3.5	169.2	47.7	3.6	173.0	47.4	3.7
45	127.9	50.4	2.5	138.0	44.5	3.1	156.9	50.1	3.1	148.6	46.5	3.2	155.8	44.8	3.5	158.1	43.9	3.6
48	120.5	50.6	2.4	130.6	46.3	2.8	153.8	51.1	3.0	140.0	44.6	3.1	148.2	43.8	3.4	151.1	42.9	3.5
50	114.7	50.2	2.3	123.7	47.0	2.6	147.8	51.9	2.8	130.1	42.5	3.1	133.5	39.8	3.4	136.1	39.4	3.5
54	65.7	32.8	2.0	71.4	31.2	2.3	80.2	31.0	2.6	86.5	30.4	2.9	85.6	27.5	3.1	89.0	27.6	3.2

LWT	DB											
	30			35			40			43		
	HC	PI	COP	HC	PI	COP	HC	PI	COP	HC	PI	COP
25	220.2	52.1	4.2	226.9	50.8	4.5	216.6	46.7	4.6	211.4	44.7	4.7
30	204.2	48.5	4.2	209.8	47.5	4.4	198.0	44.4	4.5	192.1	42.6	4.5
35	191.0	44.2	4.3	198.1	44.9	4.4	183.7	44.0	4.2	178.5	42.2	4.2
40	168.7	39.4	4.3	177.1	40.5	4.4	163.5	42.8	3.8	156.8	40.4	3.9
45	150.1	40.0	3.8	158.5	41.5	3.8	143.9	41.6	3.5	136.6	39.1	3.5
48	136.1	37.6	3.6	141.5	38.4	3.7	130.2	40.4	3.2	124.5	38.0	3.3
50	124.9	35.3	3.5	129.2	36.1	3.6	117.1	38.9	3.0	111.0	36.1	3.1
54	79.1	23.8	3.3	89.1	26.4	3.4	80.8	29.3	2.8	/	/	/

Abbreviations:

HC: Total heating capacity (kW)

PI: Power input (kW)

LWT: Leaving water temperature (°C)

DB: Dry-bulb temperature for outdoor air temperature (°C)

Performance specifications measured with water pump operating at rated water flow rate.

**MUENR-140-H12T(K)**

LWT	DB																	
	-20			-18			-15			-10			-5			0		
	HC	PI	COP	HC	PI	COP	HC	PI	COP	HC	PI	COP	HC	PI	COP	HC	PI	COP
25	89.7	41.8	2.1	98.0	41.3	2.4	104.6	43.0	2.4	109.8	42.1	2.6	124.3	46.5	2.7	137.0	48.4	2.8
30	82.0	39.8	2.1	93.2	40.5	2.3	98.4	43.1	2.3	105.2	42.9	2.5	117.9	46.7	2.5	129.1	48.8	2.6
35	83.2	44.2	1.9	89.4	42.3	2.1	94.4	44.5	2.1	100.2	44.0	2.3	112.8	48.4	2.3	124.4	50.5	2.5
40	66.2	41.6	1.6	77.1	41.4	1.9	89.7	45.1	2.0	94.6	44.3	2.1	107.4	48.6	2.2	119.8	52.5	2.3
45	67.1	64.2	1.0	75.9	47.7	1.6	86.8	47.9	1.8	91.7	47.1	1.9	105.9	52.9	2.0	119.1	56.7	2.1
48	/	/	/	64.6	43.4	1.5	80.7	46.1	1.8	85.4	45.4	1.9	99.3	51.7	1.9	113.6	56.9	2.0
50	/	/	/	/	/	/	68.4	41.6	1.6	77.0	43.6	1.8	90.8	49.2	1.8	105.2	55.8	1.9
54	/	/	/	/	/	/	/	/	/	35.8	23.5	1.5	45.6	28.5	1.6	60.5	36.6	1.7

LWT	DB																	
	5			7			10			15			20			25		
	HC	PI	COP	HC	PI	COP	HC	PI	COP	HC	PI	COP	HC	PI	COP	HC	PI	COP
25	146.4	44.8	3.3	158.9	43.9	3.6	169.7	44.6	3.8	180.1	46.6	3.9	196.8	49.6	4.0	213.6	53.0	4.0
30	137.5	45.1	3.0	150.6	44.8	3.4	166.2	45.8	3.6	178.3	48.7	3.7	188.4	50.4	3.7	198.5	52.4	3.8
35	131.5	45.2	2.9	138.5	43.6	3.2	161.7	46.5	3.5	172.0	48.6	3.5	180.7	49.8	3.6	186.2	49.9	3.7
40	127.8	47.8	2.7	138.8	46.2	3.0	158.9	48.0	3.3	166.0	49.3	3.4	169.2	49.2	3.4	173.0	48.9	3.5
45	127.9	51.9	2.5	138.0	46.0	3.0	156.9	51.6	3.0	148.6	48.0	3.1	155.8	46.3	3.4	158.1	45.4	3.5
48	120.5	52.1	2.3	130.6	47.8	2.7	153.8	52.6	2.9	140.0	46.1	3.0	148.2	45.3	3.3	151.1	44.4	3.4
50	114.7	51.7	2.2	123.7	48.5	2.6	147.8	53.4	2.8	130.1	44.0	3.0	133.5	41.3	3.2	136.1	40.9	3.3
54	65.7	34.3	1.9	71.4	32.7	2.2	80.2	32.5	2.5	86.5	31.9	2.7	85.6	29.0	2.9	89.0	29.1	3.1

LWT	DB											
	30			35			40			43		
	HC	PI	COP	HC	PI	COP	HC	PI	COP	HC	PI	COP
25	220.2	53.6	4.1	226.9	52.3	4.3	216.6	48.2	4.5	211.4	46.2	4.6
30	204.2	50.0	4.1	209.8	49.0	4.3	198.0	45.9	4.3	192.1	44.1	4.4
35	191.0	45.7	4.2	198.1	46.4	4.3	183.7	45.5	4.0	178.5	43.7	4.1
40	168.7	40.9	4.1	177.1	42.0	4.2	163.5	44.3	3.7	156.8	41.9	3.7
45	150.1	41.5	3.6	158.5	43.0	3.7	143.9	43.1	3.3	136.6	40.6	3.4
48	136.1	39.1	3.5	141.5	39.9	3.5	130.2	41.9	3.1	124.5	39.5	3.1
50	124.9	36.8	3.4	129.2	37.6	3.4	117.1	40.4	2.9	111.0	37.6	3.0
54	79.1	25.3	3.1	89.1	27.9	3.2	80.8	30.8	2.6	/	/	/

Abbreviations:

HC: Total heating capacity (kW)

PI: Power input (kW)

LWT: Leaving water temperature (°C)

DB: Dry-bulb temperature for outdoor air temperature (°C)

Performance specifications measured with water pump operating at rated water flow rate.

**MUENR-180-H12T**

LWT	DB																	
	-20			-18			-15			-10			-7			-4		
	HC	PI	COP	HC	PI	COP	HC	PI	COP	HC	PI	COP	HC	PI	COP	HC	PI	COP
25	89.5	42.5	2.1	99.1	43.9	2.3	111.8	45.7	2.4	134.8	46.8	2.9	148.1	48.1	3.1	158.2	48.9	3.2
30	87.9	43.7	2.0	97.4	45.1	2.2	109.8	47.0	2.3	132.4	48.1	2.8	145.5	49.4	2.9	155.4	50.3	3.1
35	85.3	50.0	1.7	94.1	50.8	1.9	106.0	51.9	2.0	127.9	52.5	2.4	141.0	52.7	2.7	151.1	52.9	2.9
40	79.4	53.6	1.4	88.4	54.4	1.6	100.8	55.9	1.8	123.3	56.9	2.2	136.9	57.4	2.4	147.3	57.7	2.6
42	/	/	/	84.8	56.9	1.5	97.3	57.3	1.7	120.3	57.6	2.1	134.2	58.7	2.3	144.8	59.3	2.4
45	/	/	/	/	/	/	92.7	59.8	1.5	114.5	58.8	1.9	128.8	60.7	2.1	139.8	62.0	2.3
47	/	/	/	/	/	/	/	/	/	103.8	57.3	1.8	118.1	59.7	2.0	129.0	61.2	2.1
48	/	/	/	/	/	/	/	/	/	97.2	55.8	1.7	111.4	58.5	1.9	122.3	60.3	2.0
50	/	/	/	/	/	/	/	/	/	/	/	/	101.0	57.4	1.8	110.7	59.1	1.9
54	/	/	/	/	/	/	/	/	/	/	/	/	/	/	/	95.0	59.5	1.6

LWT	DB																	
	0			5			7			10			15			20		
	HC	PI	COP	HC	PI	COP	HC	PI	COP	HC	PI	COP	HC	PI	COP	HC	PI	COP
25	174.3	51.2	3.4	190.3	47.0	4.1	198.2	46.5	4.3	206.0	45.4	4.5	207.5	44.8	4.6	207.8	43.6	4.8
30	171.2	52.6	3.3	188.0	48.6	3.9	196.5	47.0	4.2	204.2	46.8	4.4	205.7	46.1	4.5	206.0	44.9	4.6
35	167.1	53.1	3.1	183.0	49.9	3.7	190.8	49.6	3.9	199.2	49.8	4.0	200.9	49.2	4.1	200.5	47.4	4.2
40	164.0	57.9	2.8	178.6	56.2	3.2	185.4	54.2	3.4	196.1	51.8	3.8	198.2	51.1	3.9	199.2	49.4	4.0
42	161.7	59.8	2.7	176.8	57.0	3.1	183.9	55.4	3.3	195.0	53.6	3.6	197.3	52.9	3.7	198.1	49.8	4.0
45	157.0	62.7	2.5	173.3	58.3	3.0	180.0	57.0	3.2	193.0	56.5	3.4	195.4	55.7	3.5	196.0	50.3	3.9
47	147.3	63.0	2.3	166.7	63.3	2.6	175.3	61.6	2.8	184.1	56.2	3.3	185.7	55.1	3.4	181.9	48.4	3.8
48	142.1	63.0	2.3	162.6	66.1	2.5	172.3	64.2	2.7	178.6	55.7	3.2	179.8	54.5	3.3	173.3	46.9	3.7
50	132.2	63.2	2.1	155.5	67.3	2.3	166.6	69.2	2.4	168.9	53.6	3.2	169.4	52.1	3.3	158.2	44.7	3.5
54	113.2	65.1	1.7	132.8	67.4	2.0	142.1	68.4	2.1	146.8	52.3	2.8	147.8	50.9	2.9	140.5	42.7	3.3

LWT	DB														
	25			30			35			40			43		
	HC	PI	COP	HC	PI	COP	HC	PI	COP	HC	PI	COP	HC	PI	COP
25	205.7	40.2	5.1	200.1	35.5	5.6	187.3	30.1	6.2	179.2	28.5	6.3	177.6	27.7	6.4
30	203.9	41.3	4.9	198.4	36.5	5.4	185.7	31.0	6.0	177.7	29.3	6.1	176.1	28.5	6.2
35	200.5	41.4	4.8	192.0	36.8	5.2	178.0	32.0	5.6	160.0	27.9	5.7	157.2	26.8	5.9
40	198.6	42.7	4.7	189.2	37.6	5.0	170.0	32.9	5.2	142.8	26.0	5.5	140.1	25.0	5.6
42	196.9	43.8	4.5	182.7	37.7	4.8	164.5	32.7	5.0	139.1	26.0	5.3	136.3	24.9	5.5
45	193.6	45.6	4.3	169.8	37.9	4.5	153.6	32.5	4.7	132.0	25.9	5.1	128.6	24.7	5.2
47	173.4	42.7	4.1	155.6	36.4	4.3	141.7	31.6	4.5	124.1	25.4	4.9	120.2	23.9	5.0
48	161.0	40.6	4.0	143.5	34.5	4.2	130.6	29.8	4.4	114.4	24.0	4.8	/	/	/
50	139.2	37.3	3.7	126.0	32.4	3.9	/	/	/	/	/	/	/	/	/
54	117.9	33.3	3.5	94.0	25.3	3.7	/	/	/	/	/	/	/	/	/

Abbreviations:

HC: Total heating capacity (kW)

PI: Power input (kW)

LWT: Leaving water temperature (°C)

DB: Dry-bulb temperature for outdoor air temperature (°C)

Performance specifications measured with water pump operating at rated water flow rate..

**MUENR-180-H12T(K)**

LWT	DB																	
	-20			-18			-15			-10			-7			-4		
	HC	PI	COP	HC	PI	COP	HC	PI	COP	HC	PI	COP	HC	PI	COP	HC	PI	COP
25	89.5	42.5	2.1	99.1	43.9	2.3	111.8	45.7	2.4	134.8	46.8	2.9	148.1	48.1	3.1	158.2	48.9	3.2
30	87.9	43.7	2.0	97.4	45.1	2.2	109.8	47.0	2.3	132.4	48.1	2.8	145.5	49.4	2.9	155.4	50.3	3.1
35	85.3	50.0	1.7	94.1	50.8	1.9	106.0	51.9	2.0	127.9	52.5	2.4	141.0	52.7	2.7	151.1	52.9	2.9
40	79.4	53.6	1.5	88.4	54.4	1.6	100.8	55.9	1.8	123.3	56.9	2.2	136.9	57.4	2.4	147.3	57.7	2.6
42				84.8	56.9	1.5	97.3	57.3	1.7	120.3	57.6	2.1	134.2	58.7	2.3	144.8	59.3	2.4
45							92.7	59.8	1.5	114.5	58.8	1.9	128.8	60.7	2.1	139.8	62.0	2.3
47										103.8	57.3	1.8	118.1	59.7	2.0	129.0	61.2	2.1
48										97.2	55.8	1.7	111.4	58.5	1.9	122.3	60.3	2.0
50													101.0	57.4	1.8	110.7	59.1	1.9
54																95.0	59.5	1.6

LWT	DB																	
	0			5			7			10			15			20		
	HC	PI	COP	HC	PI	COP	HC	PI	COP	HC	PI	COP	HC	PI	COP	HC	PI	COP
25	174.3	51.2	3.4	190.3	47.0	4.1	198.2	46.5	4.3	206.0	45.4	4.5	207.5	44.8	4.6	207.8	43.6	4.8
30	171.2	52.6	3.3	188.0	48.6	3.9	196.5	47.0	4.2	204.2	46.8	4.4	205.7	46.1	4.5	206.0	44.9	4.6
35	167.1	53.1	3.1	183.0	49.9	3.7	190.8	49.6	3.9	199.2	49.8	4.0	200.9	49.2	4.1	200.5	47.4	4.2
40	164.0	57.9	2.8	178.6	56.2	3.2	185.4	54.2	3.4	196.1	51.8	3.8	198.2	51.1	3.9	199.2	49.4	4.0
42	161.7	59.8	2.7	176.8	57.0	3.1	183.9	55.4	3.3	195.0	53.6	3.6	197.3	52.9	3.7	198.1	49.8	4.0
45	157.0	62.7	2.5	173.3	58.3	3.0	180.0	57.0	3.2	193.0	56.5	3.4	195.4	55.7	3.5	196.0	50.3	3.9
47	147.3	63.0	2.3	166.7	63.3	2.6	175.3	61.6	2.8	184.1	56.2	3.3	185.7	55.1	3.4	181.9	48.4	3.8
48	142.1	63.0	2.3	162.6	66.1	2.5	172.3	64.2	2.7	178.6	55.7	3.2	179.8	54.5	3.3	173.3	46.9	3.7
50	132.2	63.2	2.1	155.5	67.3	2.3	166.6	69.2	2.4	168.9	53.6	3.2	169.4	52.1	3.3	158.2	44.7	3.5
54	113.2	65.1	1.7	132.8	67.4	2.0	142.1	68.4	2.1	146.8	52.3	2.8	147.8	50.9	2.9	140.5	42.7	3.3

LWT	DB														
	25			30			35			40			43		
	HC	PI	COP	HC	PI	COP	HC	PI	COP	HC	PI	COP	HC	PI	COP
25	205.7	40.2	5.1	200.1	35.5	5.6	187.3	30.1	6.2	179.2	28.5	6.3	177.6	27.7	6.4
30	203.9	41.3	4.9	198.4	36.5	5.4	185.7	31.0	6.0	177.7	29.3	6.1	176.1	28.5	6.2
35	200.5	41.4	4.8	192.0	36.8	5.2	178.0	32.0	5.6	160.0	27.9	5.7	157.2	26.8	5.9
40	198.6	42.7	4.7	189.2	37.6	5.0	170.0	32.9	5.2	142.8	26.0	5.5	140.1	25.0	5.6
42	196.9	43.8	4.5	182.7	37.7	4.8	164.5	32.7	5.0	139.1	26.0	5.3	136.3	24.9	5.5
45	193.6	45.6	4.3	169.8	37.9	4.5	153.6	32.5	4.7	132.0	25.9	5.1	128.6	24.7	5.2
47	173.4	42.7	4.1	155.6	36.4	4.3	141.7	31.6	4.5	124.1	25.4	4.9	120.2	23.9	5.0
48	161.0	40.6	4.0	143.5	34.5	4.2	130.6	29.8	4.4	114.4	24.0	4.8			
50	139.2	37.3	3.7	126.0	32.4	3.9									
54	117.9	33.3	3.5	94.0	25.3	3.7									

Abbreviations:

HC: Total heating capacity (kW)

PI: Power input (kW)

LWT: Leaving water temperature (°C)

DB: Dry-bulb temperature for outdoor air temperature (°C)

Performance specifications measured with water pump operating at rated water flow rate.

## 5.2 Cooling Capacity Tables

### MUENR-75-H12T

LWT	DB																	
	-10			-5			0			5			10			15		
	CC	PI	EER	CC	PI	EER	CC	PI	EER	CC	PI	EER	CC	PI	EER	CC	PI	EER
0	44.4	8.1	5.5	43.6	8.7	5.0	41.3	9.3	4.5	39.0	10.1	3.9	52.0	17.7	2.9	61.1	17.7	3.2
5	54.5	9.4	5.8	53.7	10.1	5.3	51.5	10.7	4.8	49.7	11.4	4.3	60.5	18.6	3.3	69.0	18.9	3.7
7	57.6	9.8	5.9	56.6	10.4	5.4	54.2	11.1	4.9	52.8	11.8	4.5	66.7	19.8	3.4	75.5	20.2	3.7
10	61.9	10.3	6.0	61.0	11.0	5.6	58.9	11.7	5.0	57.2	12.5	4.6	68.2	19.8	3.4	82.3	20.8	4.0
15	70.8	10.4	6.8	69.6	11.6	6.0	66.5	11.4	5.8	65.4	11.6	5.7	66.9	17.4	3.8	90.8	18.4	4.9
20	78.4	11.3	6.9	77.5	12.0	6.5	76.5	12.3	6.2	74.4	12.1	6.2	68.3	16.7	4.1	95.9	18.6	5.2

LWT	DB																	
	20			25			30			35			40			43		
	CC	PI	EER	CC	PI	EER	CC	PI	EER	CC	PI	EER	CC	PI	EER	CC	PI	EER
0	60.5	18.0	3.1	59.9	18.7	3.0	59.4	22.3	2.5	56.9	24.3	2.2	36.5	16.5	2.1	23.2	11.4	1.9
5	68.2	19.3	3.5	67.6	20.0	3.4	67.0	23.8	2.8	64.2	26.0	2.5	41.2	17.6	2.3	26.2	12.1	2.2
7	75.1	20.4	3.7	74.2	21.4	3.5	70.8	24.2	2.9	70.0	26.8	2.6	47.3	18.8	2.5	31.8	13.5	2.4
10	81.2	21.1	3.8	79.3	21.4	3.7	77.4	24.9	3.1	74.8	27.1	2.8	51.6	19.1	2.7	35.5	13.7	2.6
15	88.0	19.5	4.5	86.8	20.9	4.2	82.4	23.0	3.6	78.7	24.5	3.2	53.2	16.8	3.2	37.1	12.5	3.0
20	94.5	19.6	4.8	93.5	21.3	4.4	91.6	23.0	4.0	87.4	23.2	3.8	58.0	15.8	3.7	43.3	12.7	3.4

LWT	DB					
	45			48		
	CC	PI	EER	CC	PI	EER
0	21.3	11.2	1.8	11.3	8.3	1.3
5	24.1	11.9	2.0	12.7	8.9	1.4
7	27.4	12.6	2.2	14.5	8.9	1.6
10	31.2	12.9	2.4	17.1	9.0	1.9
15	33.9	12.1	2.8	21.3	9.0	2.4
20	39.0	12.3	3.2	25.1	9.0	2.8

Abbreviations:

CC: Total cooling capacity (kW)

PI: Power input (kW)

LWT: Leaving water temperature (°C)

DB: Dry-bulb temperature for outdoor air temperature (°C)

Notes: Performance specifications measured with water pump operating at rated water flow rate.

**MUENR-75-H12T(K)**

LWT	DB																	
	-10			-5			0			5			10			15		
	CC	PI	EER	CC	PI	EER	CC	PI	EER	CC	PI	EER	CC	PI	EER	CC	PI	EER
0	44.4	9.2	4.8	43.6	9.8	4.4	41.3	10.5	4.0	39.0	11.3	3.5	52.0	19.2	2.7	61.1	19.2	3.2
5	54.5	10.8	5.1	53.7	11.4	4.7	51.5	12.1	4.3	49.7	12.8	3.9	60.5	20.1	3.0	69.0	20.4	3.4
7	57.6	11.2	5.1	56.6	11.9	4.8	54.2	12.5	4.3	52.8	13.3	4.0	66.7	21.3	3.1	75.5	21.7	3.5
10	61.9	11.8	5.2	61.0	12.5	4.9	58.9	13.2	4.5	57.2	14.0	4.1	68.2	21.3	3.2	82.3	22.3	3.7
15	70.8	11.9	5.9	69.6	13.1	5.3	66.5	12.9	5.2	65.4	13.1	5.0	66.9	18.9	3.5	90.8	19.9	4.6
20	78.4	12.8	6.1	77.5	13.5	5.7	76.5	13.8	5.6	74.4	13.6	5.5	68.3	18.2	3.8	95.9	20.1	4.8

LWT	DB																	
	20			25			30			35			40			43		
	CC	PI	EER	CC	PI	EER	CC	PI	EER	CC	PI	EER	CC	PI	EER	CC	PI	EER
0	60.5	19.5	3.1	59.9	20.2	3.0	59.4	23.8	2.5	56.9	25.8	2.2	36.5	18.0	2.0	23.2	12.9	1.8
5	68.2	20.8	3.3	67.6	21.5	3.1	67.0	25.3	2.6	64.2	27.5	2.3	41.2	19.1	2.2	26.2	13.6	1.9
7	75.1	21.9	3.4	74.2	22.9	3.2	70.8	25.7	2.8	70.0	28.3	2.5	47.3	20.3	2.3	31.8	15.0	2.1
10	81.2	22.6	3.6	79.3	22.9	3.5	77.4	26.4	2.9	74.8	28.6	2.6	51.6	20.6	2.5	35.5	15.2	2.3
15	88.0	21.0	4.2	86.8	22.4	3.9	82.4	24.5	3.4	78.7	26.0	3.0	53.2	18.3	2.9	37.1	14.0	2.6
20	94.5	21.1	4.5	93.5	22.8	4.1	91.6	24.5	3.7	87.4	24.7	3.5	58.0	17.3	3.3	43.3	14.2	3.0

LWT	DB					
	45			48		
	CC	PI	EER	CC	PI	EER
0	21.3	12.7	1.7	11.3	9.8	1.1
5	24.1	13.4	1.8	12.7	10.4	1.2
7	27.4	14.1	1.9	14.5	10.4	1.4
10	31.2	14.4	2.2	17.1	10.5	1.6
15	33.9	13.6	2.5	21.3	10.5	2.0
20	39.0	13.8	2.8	25.1	10.5	2.4

Abbreviations:

CC: Total cooling capacity (kW)

PI: Power input (kW)

LWT: Leaving water temperature (°C)

DB: Dry-bulb temperature for outdoor air temperature (°C)

Notes: Performance specifications measured with water pump operating at rated water flow rate.

**MUENR-90-H12T**

LWT	DB																	
	-10			-5			0			5			10			15		
	CC	PI	EER	CC	PI	EER	CC	PI	EER	CC	PI	EER	CC	PI	EER	CC	PI	EER
0	54.4	14.6	3.7	54.2	12.6	4.3	53.7	12.0	4.5	51.7	14.0	3.7	81.9	18.8	4.4	81.5	25.5	3.2
5	66.7	17.0	3.9	66.8	14.6	4.6	67.0	13.9	4.8	65.8	15.9	4.1	94.1	26.8	3.5	93.1	27.3	3.4
7	70.5	17.6	4.0	70.4	15.2	4.6	70.5	14.4	4.9	70.0	16.5	4.2	96.3	29.6	3.3	95.6	26.4	3.6
10	75.8	18.6	4.1	75.9	16.0	4.7	76.6	15.2	5.0	75.8	17.4	4.4	106.0	27.4	3.9	111.7	29.5	3.8
15	84.0	16.4	5.1	84.1	16.2	5.2	84.0	16.9	5.0	84.1	14.8	5.7	123.7	25.6	4.8	127.2	28.1	4.5
20	92.3	14.2	6.5	92.3	16.4	5.6	91.3	18.6	4.9	91.1	14.6	6.2	129.2	26.3	4.9	133.9	28.7	4.7

LWT	DB																	
	20			25			30			35			40			43		
	CC	PI	EER	CC	PI	EER	CC	PI	EER	CC	PI	EER	CC	PI	EER	CC	PI	EER
0	78.2	26.5	3.0	76.1	20.9	3.6	74.1	24.3	3.0	68.3	29.6	2.3	57.3	27.5	2.1	46.9	24.9	1.9
5	91.8	28.7	3.2	90.3	27.8	3.2	87.4	29.5	3.0	80.9	32.2	2.5	69.9	30.2	2.3	60.9	28.2	2.2
7	94.7	30.0	3.2	93.1	21.6	4.3	89.1	28.9	3.1	82.0	27.8	2.9	71.5	25.9	2.8	63.7	24.2	2.6
10	107.6	31.5	3.4	102.9	27.5	3.7	99.9	30.3	3.3	93.7	33.0	2.8	81.6	27.7	2.9	72.2	24.2	3.0
15	117.3	29.3	4.0	111.7	25.6	4.4	108.3	25.2	4.3	104.2	28.4	3.7	92.6	28.0	3.3	81.8	24.0	3.4
20	127.1	29.4	4.3	121.3	23.5	5.2	117.3	24.7	4.7	112.4	27.5	4.1	102.3	27.9	3.7	92.1	25.3	3.6

LWT	DB					
	45			48		
	CC	PI	EER	CC	PI	EER
0	32.8	20.1	1.6	18.0	12.1	1.5
5	48.5	24.2	2.0	29.3	16.5	1.8
7	56.0	21.8	2.6	38.1	18.0	2.1
10	62.9	22.4	2.8	45.1	19.2	2.3
15	72.8	23.4	3.1	55.0	17.8	3.1
20	80.7	22.2	3.6	60.9	19.3	3.2

Abbreviations:

CC: Total cooling capacity (kW)

PI: Power input (kW)

LWT: Leaving water temperature (°C)

DB: Dry-bulb temperature for outdoor air temperature (°C)

Notes: Performance specifications measured with water pump operating at rated water flow rate.

**MUENR-90-H12T( )**

LWT	DB																	
	-10			-5			0			5			10			15		
	CC	PI	EER	CC	PI	EER	CC	PI	EER	CC	PI	EER	CC	PI	EER	CC	PI	EER
0	54.4	15.8	3.5	54.2	13.8	3.9	53.7	13.2	4.1	51.7	15.2	3.4	81.9	20.3	4.0	81.5	27.0	3.0
5	66.7	18.4	3.6	66.8	16.0	4.2	67.0	15.3	4.4	65.8	17.3	3.8	94.1	28.3	3.3	93.1	28.8	3.2
7	70.5	19.1	3.7	70.4	16.6	4.2	70.5	15.8	4.4	70.0	17.9	3.9	96.3	31.1	3.1	95.6	27.9	3.4
10	75.8	20.1	3.8	75.9	17.5	4.3	76.6	16.7	4.6	75.8	18.9	4.0	106.0	28.9	3.7	111.7	31.0	3.6
15	84.0	17.9	4.7	84.1	17.7	4.8	84.0	18.4	4.6	84.1	16.3	5.2	123.7	27.1	4.6	127.2	29.6	4.3
20	92.3	15.7	5.9	92.3	17.9	5.2	91.3	20.1	4.5	91.1	16.1	5.7	129.2	27.8	4.6	133.9	30.2	4.4

LWT	DB																	
	20			25			30			35			40			43		
	CC	PI	EER	CC	PI	EER	CC	PI	EER	CC	PI	EER	CC	PI	EER	CC	PI	EER
0	78.2	28.0	2.8	76.1	22.4	3.4	74.1	25.8	2.9	68.3	31.1	2.2	57.3	29.0	2.0	46.9	26.4	1.8
5	91.8	30.2	3.0	90.3	29.3	3.1	87.4	31.0	2.8	80.9	33.7	2.4	69.9	31.7	2.2	60.9	29.7	2.1
7	94.7	31.5	3.0	93.1	23.1	4.0	89.1	30.4	2.9	82.1	28.8	2.9	71.5	27.4	2.6	63.7	25.7	2.5
10	107.6	33.0	3.3	102.9	29.0	3.5	99.9	31.8	3.1	93.7	34.5	2.7	81.6	29.2	2.8	72.2	25.7	2.8
15	117.3	30.8	3.8	111.7	27.1	4.1	108.3	26.7	4.1	104.2	29.9	3.5	92.6	29.5	3.1	81.8	25.5	3.2
20	127.1	30.9	4.1	121.3	25.0	4.9	117.3	26.2	4.5	112.4	29.0	3.9	102.3	29.4	3.5	92.1	26.8	3.4

LWT	DB					
	45			48		
	CC	PI	EER	CC	PI	EER
0	32.8	21.6	1.5	18.0	13.6	1.3
5	48.5	25.7	1.9	29.3	18.0	1.6
7	56.0	23.3	2.4	38.1	19.5	2.0
10	62.9	23.9	2.6	45.1	20.7	2.2
15	72.8	24.9	2.9	55.0	19.3	2.8
20	80.7	23.7	3.4	60.9	20.8	2.9

Abbreviations:

CC: Total cooling capacity (kW)

PI: Power input (kW)

LWT: Leaving water temperature (°C)

DB: Dry-bulb temperature for outdoor air temperature (°C)

Notes: Performance specifications measured with water pump operating at rated water flow rate.

**MUENR-140-H12T**

LWT	DB																	
	-10			-5			0			5			10			15		
	CC	PI	EER	CC	PI	EER	CC	PI	EER	CC	PI	EER	CC	PI	EER	CC	PI	EER
0	82.1	20.1	4.1	80.6	20.3	4.0	78.1	20.7	3.8	74.8	21.3	3.5	105.2	38.4	2.7	117.4	38.0	3.1
5	100.7	23.4	4.3	99.3	23.5	4.2	97.4	24.1	4.0	95.2	24.1	3.9	120.0	40.8	2.9	135.2	40.4	3.4
7	106.4	24.3	4.4	104.7	24.4	4.3	102.4	24.8	4.1	101.3	25.0	4.0	128.2	42.7	3.0	142.2	41.2	3.5
10	114.4	25.6	4.5	112.8	25.7	4.4	111.3	26.1	4.3	109.7	26.4	4.2	133.3	42.8	3.1	146.5	41.6	3.5
15	133.7	26.3	5.1	131.8	26.2	5.0	130.5	26.4	4.9	129.2	26.6	4.9	138.2	40.7	3.4	155.0	38.5	4.0
20	144.7	25.0	5.8	143.1	25.4	5.6	141.6	25.7	5.5	140.1	25.9	5.4	146.6	40.7	3.6	156.3	37.1	4.2

LWT	DB																	
	20			25			30			35			40			43		
	CC	PI	EER	CC	PI	EER	CC	PI	EER	CC	PI	EER	CC	PI	EER	CC	PI	EER
0	111.5	38.8	2.9	110.1	40.5	2.7	108.4	44.5	2.4	106.5	49.8	2.1	86.5	41.8	2.1	74.1	38.0	1.9
5	128.4	41.1	3.1	125.6	43.3	2.9	124.5	46.8	2.7	121.7	52.9	2.3	98.3	44.5	2.2	85.1	40.6	2.1
7	136.9	41.6	3.3	133.5	45.3	3.0	132.1	47.9	2.8	130.0	50.5	2.6	104.8	43.0	2.4	91.2	41.3	2.2
10	142.8	42.4	3.4	142.1	46.1	3.1	141.1	49.0	2.9	139.1	52.5	2.7	107.7	41.3	2.6	100.9	40.9	2.5
15	151.0	39.9	3.8	148.3	44.3	3.4	147.4	46.7	3.2	146.2	49.3	3.0	115.5	40.3	2.9	110.3	39.9	2.8
20	152.9	38.1	4.0	150.2	42.4	3.5	149.8	44.7	3.4	148.4	46.9	3.2	119.9	38.7	3.1	114.9	37.7	3.0

LWT	DB					
	45			48		
	CC	PI	EER	CC	PI	EER
0	71.4	39.7	1.8	41.0	28.2	1.5
5	81.1	42.0	1.9	46.8	29.8	1.6
7	86.4	41.9	2.1	57.7	31.7	1.8
10	92.6	39.0	2.4	63.5	32.3	2.0
15	95.0	35.4	2.7	65.3	29.1	2.2
20	97.3	32.6	3.0	70.3	26.3	2.7

Abbreviations:

CC: Total cooling capacity (kW)

PI: Power input (kW)

LWT: Leaving water temperature (°C)

DB: Dry-bulb temperature for outdoor air temperature (°C)

Notes: Performance specifications measured with water pump operating at rated water flow rate.

**MUENR-140-H12T(K)**

LWT	DB																	
	-10			-5			0			5			10			15		
	CC	PI	EER	CC	PI	EER	CC	PI	EER	CC	PI	EER	CC	PI	EER	CC	PI	EER
0	82.1	21.2	3.9	80.6	21.4	3.8	78.1	21.9	3.6	74.8	22.5	3.3	105.2	39.9	2.6	117.4	39.5	3.0
5	100.7	24.8	4.1	99.3	24.9	4.0	97.4	25.5	3.8	95.2	25.5	3.7	120.0	42.3	2.8	135.2	41.9	3.2
7	106.4	25.7	4.1	104.7	25.8	4.1	102.4	26.2	3.9	101.3	26.4	3.8	128.2	44.2	2.9	142.2	42.7	3.3
10	114.4	27.1	4.2	112.8	27.2	4.1	111.3	27.6	4.0	109.7	27.9	3.9	133.3	44.3	3.0	146.5	43.1	3.4
15	133.7	27.8	4.8	131.8	27.7	4.8	130.5	27.9	4.7	129.2	28.1	4.6	138.2	42.2	3.3	155.0	40.0	3.9
20	144.7	26.5	5.5	143.1	26.9	5.3	141.6	27.2	5.2	140.1	27.4	5.1	146.6	42.2	3.5	156.3	38.6	4.0

LWT	DB																	
	20			25			30			35			40			43		
	CC	PI	EER	CC	PI	EER	CC	PI	EER	CC	PI	EER	CC	PI	EER	CC	PI	EER
0	111.5	40.3	2.8	110.1	42.0	2.6	108.4	46.0	2.4	106.5	51.3	2.1	86.5	43.3	2.0	74.1	39.5	1.9
5	128.4	42.6	3.0	125.6	44.8	2.8	124.5	48.3	2.6	121.7	54.4	2.2	98.3	46.0	2.1	85.1	42.1	2.0
7	136.9	43.1	3.2	133.5	46.8	2.9	132.1	49.4	2.7	130.0	52.0	2.5	104.8	44.5	2.4	91.2	42.8	2.1
10	142.8	43.9	3.3	142.1	47.6	3.0	141.1	50.5	2.8	139.1	54.0	2.6	107.7	42.8	2.5	100.9	42.4	2.4
15	151.0	41.4	3.6	148.3	45.8	3.2	147.4	48.2	3.1	146.2	50.8	2.9	115.5	41.8	2.8	110.3	41.4	2.7
20	152.9	39.6	3.9	150.2	43.9	3.4	149.8	46.2	3.2	148.4	48.4	3.1	119.9	40.2	3.0	114.9	39.2	2.9

LWT	DB					
	45			48		
	CC	PI	EER	CC	PI	EER
0	71.4	41.2	1.7	41.0	29.7	1.4
5	81.1	43.5	1.9	46.8	31.3	1.5
7	86.4	43.4	2.0	57.7	33.2	1.7
10	92.6	40.5	2.3	63.5	33.8	1.9
15	95.0	36.9	2.6	65.3	30.6	2.1
20	97.3	34.1	2.9	70.3	27.8	2.5

Abbreviations:

CC: Total cooling capacity (kW)

PI: Power input (kW)

LWT: Leaving water temperature (°C)

DB: Dry-bulb temperature for outdoor air temperature (°C)

Notes: Performance specifications measured with water pump operating at rated water flow rate.

**MUENR-180-H12T**

LWT	DB																	
	-10			-5			0			5			10			15		
	CC	PI	EER	CC	PI	EER	CC	PI	EER	CC	PI	EER	CC	PI	EER	CC	PI	EER
0	108.9	29.2	3.7	108.4	25.2	4.3	107.5	24.2	4.5	103.4	28.1	3.7	163.8	48.5	3.4	163.1	51.1	3.2
5	133.6	34.1	3.9	133.6	29.2	4.6	134.1	28.2	4.8	131.6	31.9	4.1	188.2	52.0	3.6	186.3	54.7	3.4
7	141.1	35.4	4.0	140.8	30.3	4.6	141.0	28.9	4.9	140.0	33.1	4.2	199.1	52.2	3.8	197.6	55.0	3.6
10	151.7	37.3	4.1	151.8	32.0	4.7	153.3	30.5	5.0	151.6	34.9	4.3	212.0	52.7	4.0	223.5	59.2	3.8
15	168.1	32.8	5.1	168.2	32.5	5.2	168.0	31.6	5.3	168.2	29.7	5.7	247.4	51.4	4.8	254.4	56.4	4.5
20	184.5	28.4	6.5	184.5	32.9	5.6	182.6	30.6	6.0	182.3	29.3	6.2	258.5	48.6	5.3	267.8	56.3	4.8

LWT	DB																	
	20			25			30			35			40			43		
	CC	PI	EER	CC	PI	EER	CC	PI	EER	CC	PI	EER	CC	PI	EER	CC	PI	EER
0	156.5	50.5	3.1	152.1	50.4	3.0	148.2	48.8	3.0	136.7	59.3	2.3	114.7	55.3	2.1	93.8	50.0	1.9
5	183.5	56.3	3.3	180.6	57.7	3.1	174.9	59.1	3.0	161.7	64.7	2.5	139.8	60.7	2.3	121.9	56.7	2.2
7	195.6	57.2	3.4	192.4	59.6	3.2	184.2	60.2	3.1	164.0	56.0	2.9	147.7	54.0	2.7	131.7	50.3	2.6
10	215.1	59.4	3.6	205.8	60.0	3.4	199.7	60.7	3.3	187.5	59.5	3.1	163.3	54.8	3.0	144.4	50.0	2.9
15	234.6	58.8	4.0	223.4	51.4	4.3	216.5	50.5	4.3	208.4	56.9	3.7	185.1	56.3	3.3	163.7	50.7	3.2
20	254.3	59.0	4.3	242.7	47.1	5.2	234.6	49.7	4.7	224.7	55.2	4.1	204.7	55.9	3.7	184.2	52.5	3.5

LWT	DB					
	45			48		
	CC	PI	EER	CC	PI	EER
0	65.6	40.3	1.6	36.0	24.4	1.5
5	96.9	48.6	2.0	58.6	33.2	1.8
7	115.7	45.5	2.5	78.6	37.6	2.1
10	125.8	45.0	2.8	90.2	38.5	2.3
15	145.6	46.9	3.1	110.0	38.6	2.9
20	161.3	48.0	3.4	121.7	38.8	3.1

Abbreviations:

CC: Total cooling capacity (kW)

PI: Power input (kW)

LWT: Leaving water temperature (°C)

DB: Dry-bulb temperature for outdoor air temperature (°C)

Notes: Performance specifications measured with water pump operating at rated water flow rate.

**MUENR-180-H12T(K)**

LWT	DB																	
	-10			-5			0			5			10			15		
	CC	PI	EER	CC	PI	EER	CC	PI	EER	CC	PI	EER	CC	PI	EER	CC	PI	EER
0	108.9	29.2	3.7	108.4	25.2	4.3	107.5	24.2	4.5	103.4	28.1	3.7	163.8	48.5	3.4	163.1	51.1	3.2
5	133.6	34.1	3.9	133.6	29.2	4.6	134.1	28.2	4.8	131.6	31.9	4.1	188.2	52.0	3.6	186.3	54.7	3.4
7	141.1	35.4	4.0	140.8	30.3	4.6	141.0	28.9	4.9	140.0	33.1	4.2	199.1	52.2	3.8	197.6	55.0	3.6
10	151.7	37.3	4.1	151.8	32.0	4.7	153.3	30.5	5.0	151.6	34.9	4.3	212.0	52.7	4.0	223.5	59.2	3.8
15	168.1	32.8	5.1	168.2	32.5	5.2	168.0	31.6	5.3	168.2	29.7	5.7	247.4	51.4	4.8	254.4	56.4	4.5
20	184.5	28.4	6.5	184.5	32.9	5.6	182.6	30.6	6.0	182.3	29.3	6.2	258.5	48.6	5.3	267.8	56.3	4.8

LWT	DB																	
	20			25			30			35			40			43		
	CC	PI	EER	CC	PI	EER	CC	PI	EER	CC	PI	EER	CC	PI	EER	CC	PI	EER
0	156.5	50.5	3.1	152.1	50.4	3.0	148.2	48.8	3.0	136.7	59.3	2.3	114.7	55.3	2.1	93.8	50.0	1.9
5	183.5	56.3	3.3	180.6	57.7	3.1	174.9	59.1	3.0	161.7	64.7	2.5	139.8	60.7	2.3	121.9	56.7	2.2
7	195.6	57.2	3.4	192.4	59.6	3.2	184.2	60.2	3.1	164.0	57.5	2.9	147.7	54.0	2.7	131.7	50.3	2.6
10	215.1	59.4	3.6	205.8	60.0	3.4	199.7	60.7	3.3	187.5	59.5	3.1	163.3	54.8	3.0	144.4	50.0	2.9
15	234.6	58.8	4.0	223.4	51.4	4.3	216.5	50.5	4.3	208.4	56.9	3.7	185.1	56.3	3.3	163.7	50.7	3.2
20	254.3	59.0	4.3	242.7	47.1	5.2	234.6	49.7	4.7	224.7	55.2	4.1	204.7	55.9	3.7	184.2	52.5	3.5

LWT	DB					
	45			48		
	CC	PI	EER	CC	PI	EER
0	65.6	40.3	1.6	36.0	24.4	1.5
5	96.9	48.6	2.0	58.6	33.2	1.8
7	115.7	45.5	2.5	78.6	37.6	2.1
10	125.8	45.0	2.8	90.2	38.5	2.3
15	145.6	46.9	3.1	110.0	38.6	2.9
20	161.3	48.0	3.4	121.7	38.8	3.1

Abbreviations:

CC: Total cooling capacity (kW)

PI: Power input (kW)

LWT: Leaving water temperature (°C)

DB: Dry-bulb temperature for outdoor air temperature (°C)

Notes: Performance specifications measured with water pump operating at rated water flow rate.

## 6 Performance Adjustment Factors

### 6.1 Ethylene and Propylene Glycol factors

The antifreeze must be required according to anyone condition as following:

- The ambient temperature is below 0 °C,
- The outlet water temperature is lower than 50 °C,
- Don't start up the unit for a long time,
- The power supply was cut off and needn't change the water in system.

A glycol solution is required when the unit with condition as mentioned. The use of glycol will reduce the performance of the unit depending on concentration.

Concentration of ethylene glycol (%)	Modification coefficient				Freezing point (°C)
	Cooling capacity	Power input	Water resistance	Water flow	
0	1.000	1.000	1.000	1.000	0
10	0.993	0.997	1.013	1.034	-3
20	0.984	0.994	1.149	1.051	-8
30	0.975	0.989	1.343	1.075	-14.1
40	0.969	0.984	1.623	1.110	-23.3
50	0.961	0.978	2.026	1.150	-33.8

Concentration of propylene glycol (%)	Modification coefficient				Freezing point (°C)
	Cooling capacity	Power input	Water resistance	Water flow	
0	1.000	1.000	1.000	1.000	0
10	0.987	0.992	1.071	1.007	-3
20	0.975	0.985	1.215	1.010	-7
30	0.962	0.978	1.420	1.021	-13
40	0.946	0.971	1.716	1.036	-21
50	0.929	0.965	2.228	1.061	-33

### 6.2 Evaporator temperature drop factors

Performance tables are based on a 5°C temperature drop through the evaporator. Temperature drops outside this range can affect the control system's capability to maintain acceptable control and are not recommended.

### 6.3 Altitude correction factors

Performance tables are based at sea level. Elevations other than sea level affect the performance of the unit. The decreased air density will reduce condenser capacity and reduce the unit's performance. Maximum allowable altitude is 1800meters.

### 6.4 Fouling factor

Fouling refers to the accumulation of unwanted material on solid surfaces, most often in an aquatic environment. The fouling material can consist of either living organisms (biofouling) or a non-living substance (inorganic or organic). Fouling is usually distinguished from other surface-growth phenomena in that it occurs on a surface of a component, system or plant performing a defined and useful function, and that the fouling process impedes or interferes with this function.

Other terms used in the literature to describe fouling include: deposit formation, encrustation, crudding, deposition, scaling,

scale formation, slagging, and sludge formation. The last six terms have a more narrow meaning than fouling within the scope of the fouling science and technology, and they also have meanings outside of this scope; therefore, they should be used with caution.

Fouling phenomena are common and diverse, ranging from fouling of ship hulls, natural surfaces in the marine environment (marine fouling), fouling of heat-transfer components through ingredients contained in the cooling water or gases, and even the development of plaque or calculus on teeth, or deposits on solar panels on Mars, among other examples.

Foreign matter in the chilled water system will adversely affect the heat transfer capability of the evaporator, and could increase the pressure drop and reduce the water flow. To provide optimum unit operation, proper water treatment must be maintained. Refer to the table as following.

ALTITUDE (m)	Difference of water inlet and outlet temp. (°C)	Fouling Factor							
		0.018 m <sup>2</sup> . °C /kW		0.044 m <sup>2</sup> . °C /kW		0.086 m <sup>2</sup> . °C /kW		0.172 m <sup>2</sup> . °C /kW	
		C	P	C	P	C	P	C	P
Sea level	3	1.036	1.077	1.019	1.076	0.991	0.975	0.963	0.983
	4	1.039	1.101	1.022	1.080	0.994	0.996	0.971	0.984
	5	1.045	1.105	1.028	1.086	1.000	1.000	0.977	0.989
	6	1.051	1.109	1.034	1.093	1.006	1.004	0.983	0.994
600	3	1.024	1.087	1.008	1.064	0.980	0.984	0.951	0.991
	4	1.027	1.111	1.011	1.068	0.983	1.005	0.959	0.992
	5	1.034	1.115	1.017	1.074	0.989	1.009	0.965	0.997
	6	1.043	1.115	1.026	1.084	0.998	1.009	0.973	0.999
1200	3	1.013	1.117	0.996	1.052	0.969	1.011	0.942	1.002
	4	1.015	1.118	0.998	1.055	0.971	1.012	0.948	1.003
	5	1.023	1.122	1.006	1.063	0.979	1.015	0.955	1.005
	6	1.031	1.125	1.015	1.072	0.987	1.018	0.962	1.007
1800	3	1.002	1.128	0.986	1.042	0.959	1.021	0.935	1.007
	4	1.005	1.129	0.989	1.045	0.962	1.022	0.941	1.010
	5	1.012	1.132	0.995	1.051	0.968	1.024	0.945	1.012
	6	1.018	1.134	1.001	1.058	0.974	1.026	0.949	1.014

Abbreviations:  
 C: Cooling capacity  
 P: Power input

## 7 Hydronic Performance

MUENR-75-H12T

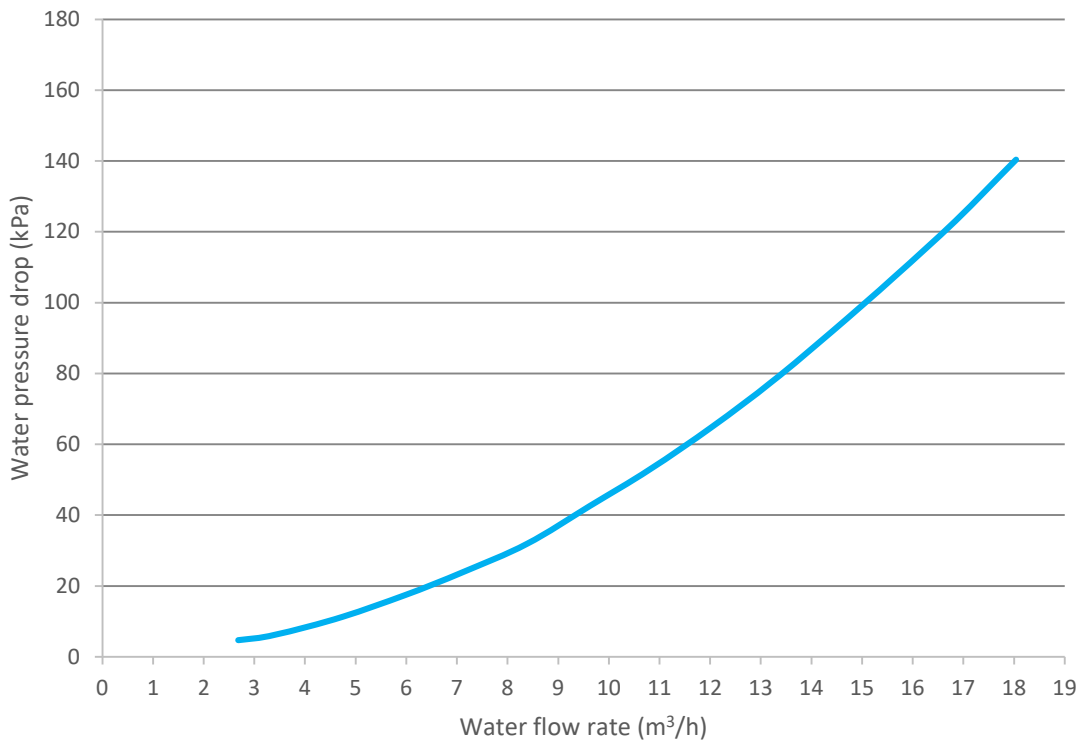

MUENR-90-H12T

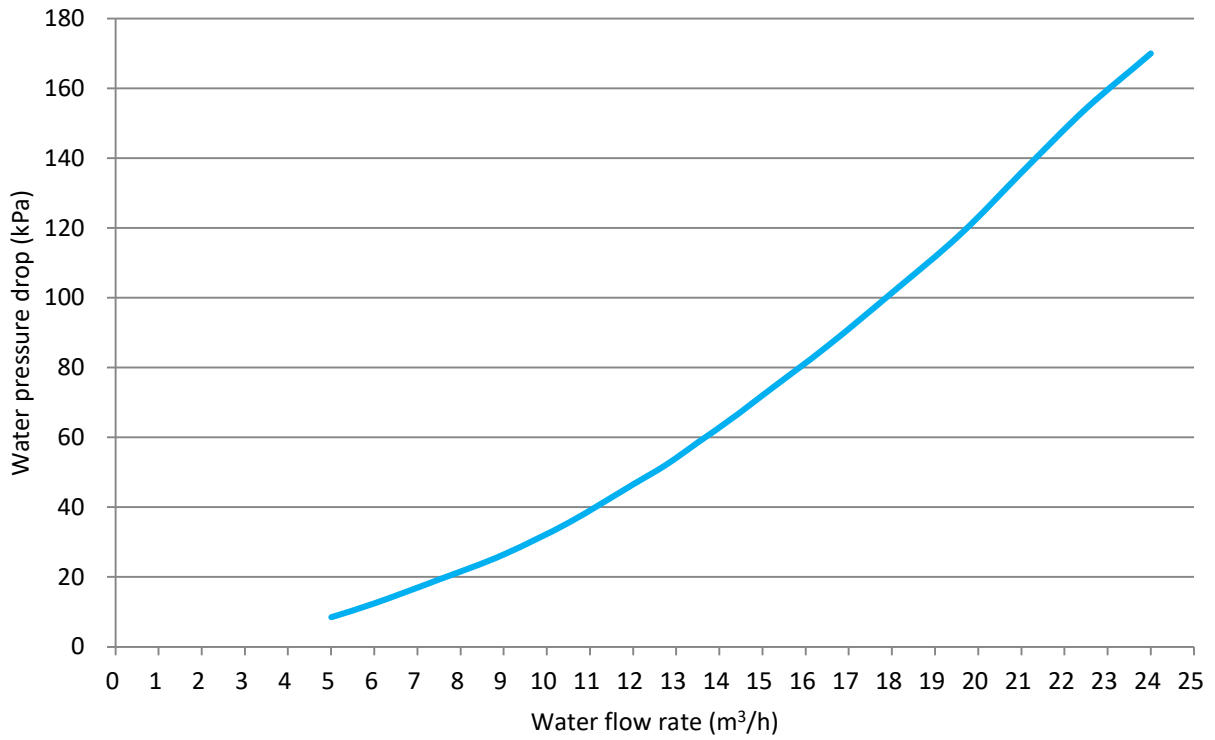

**MUENR-140-H12T**

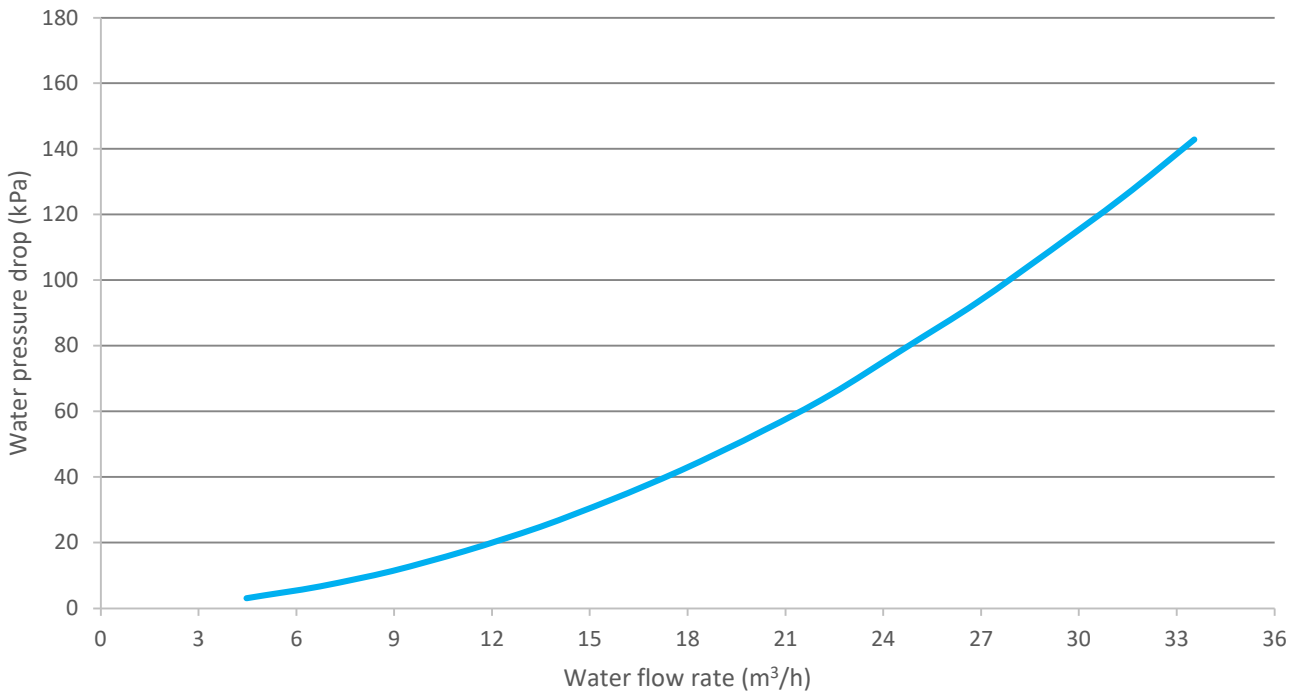

**MUENR-180-H12T**

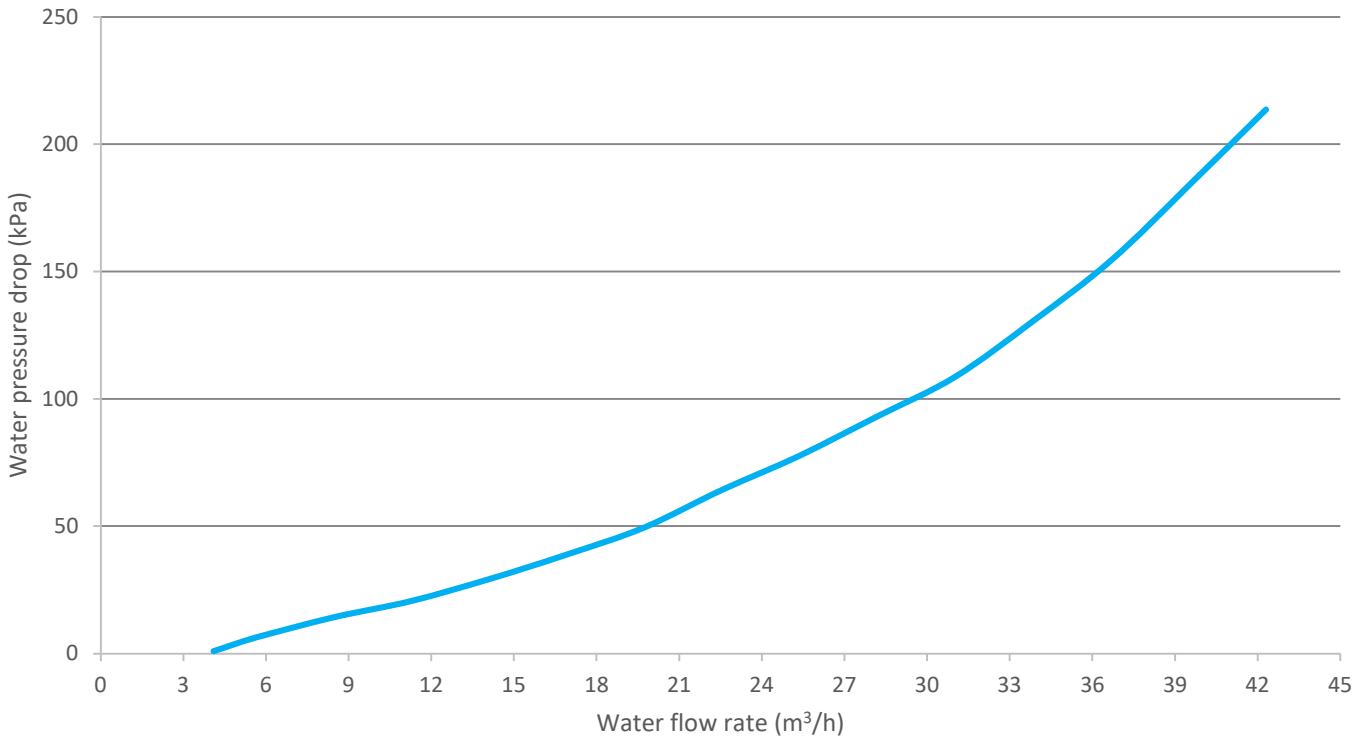

**MUENR-75-H12T(K)**

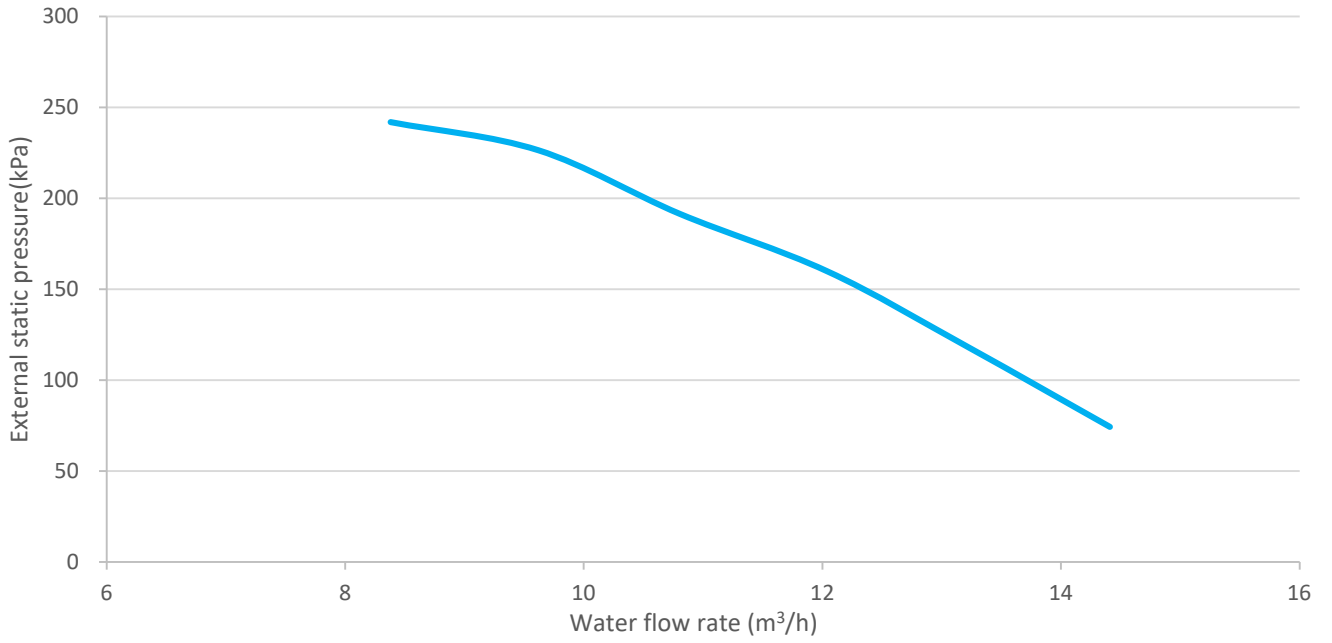

**MUENR-90-H12T(K)**

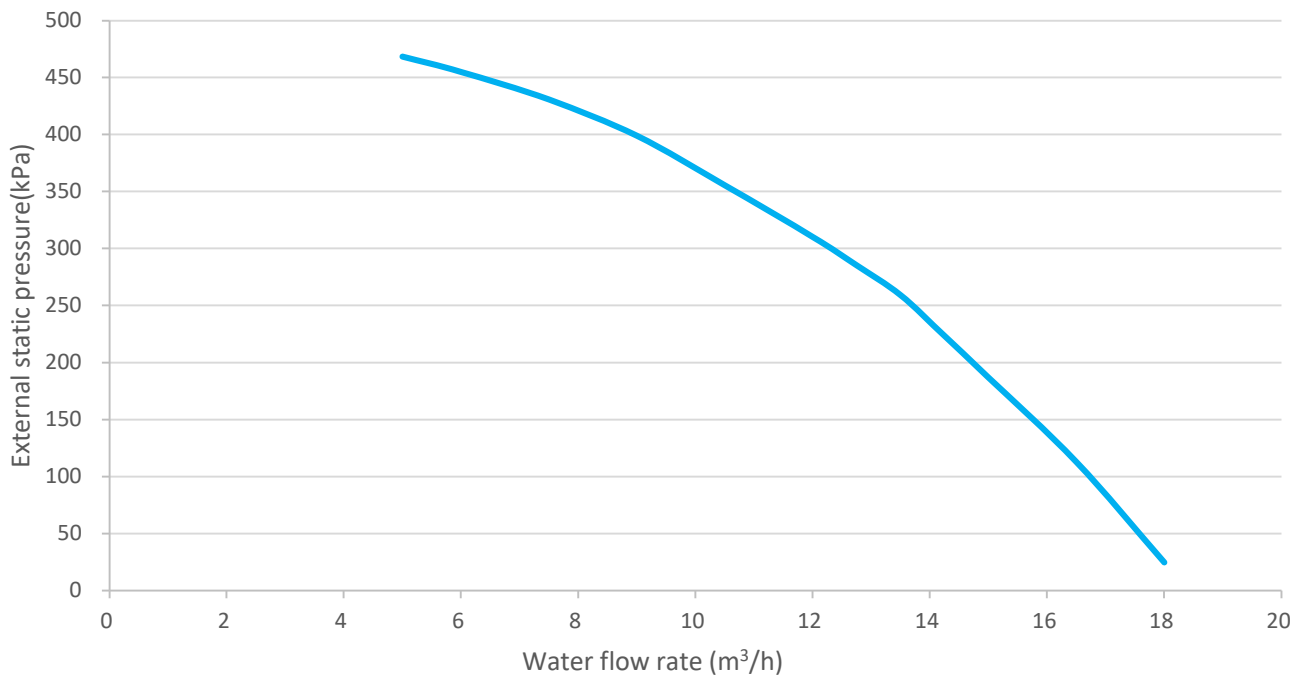

**MUENR-140-H12T(K)**

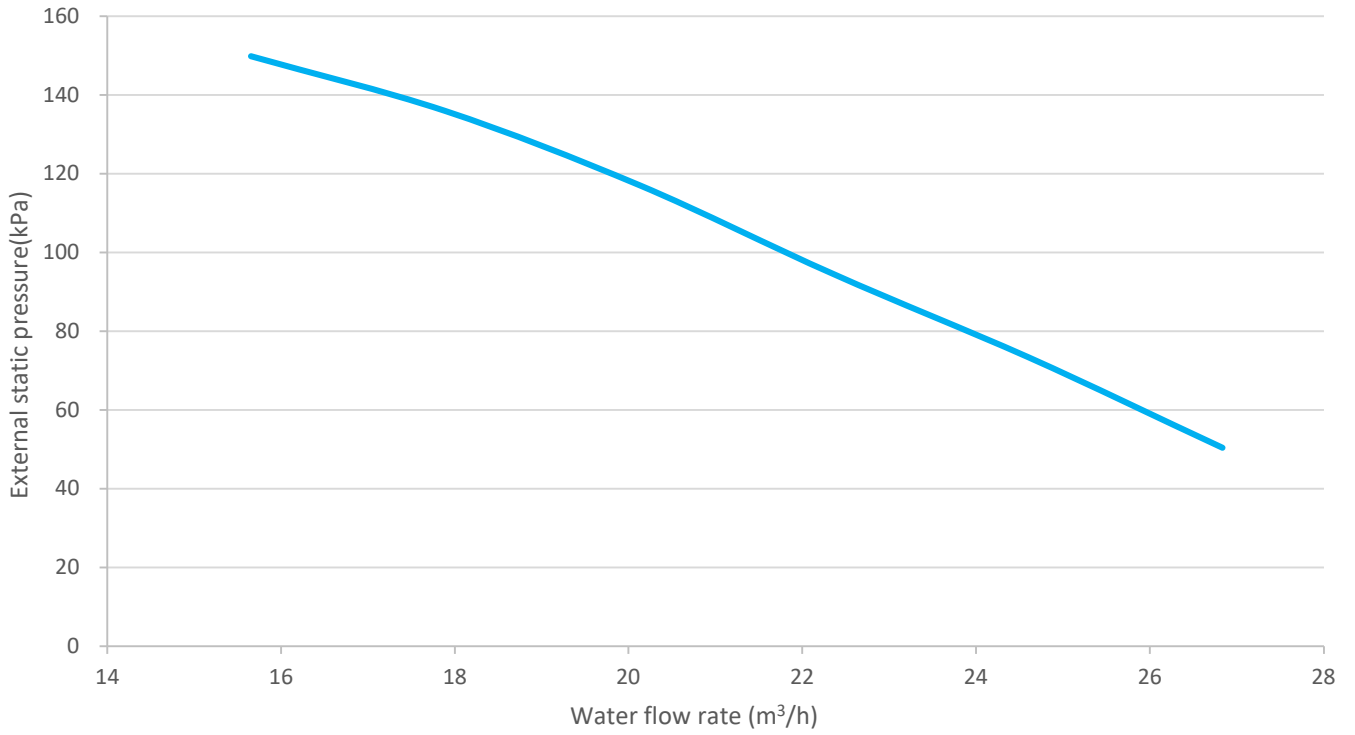

**MUENR-180-H12T(K)**

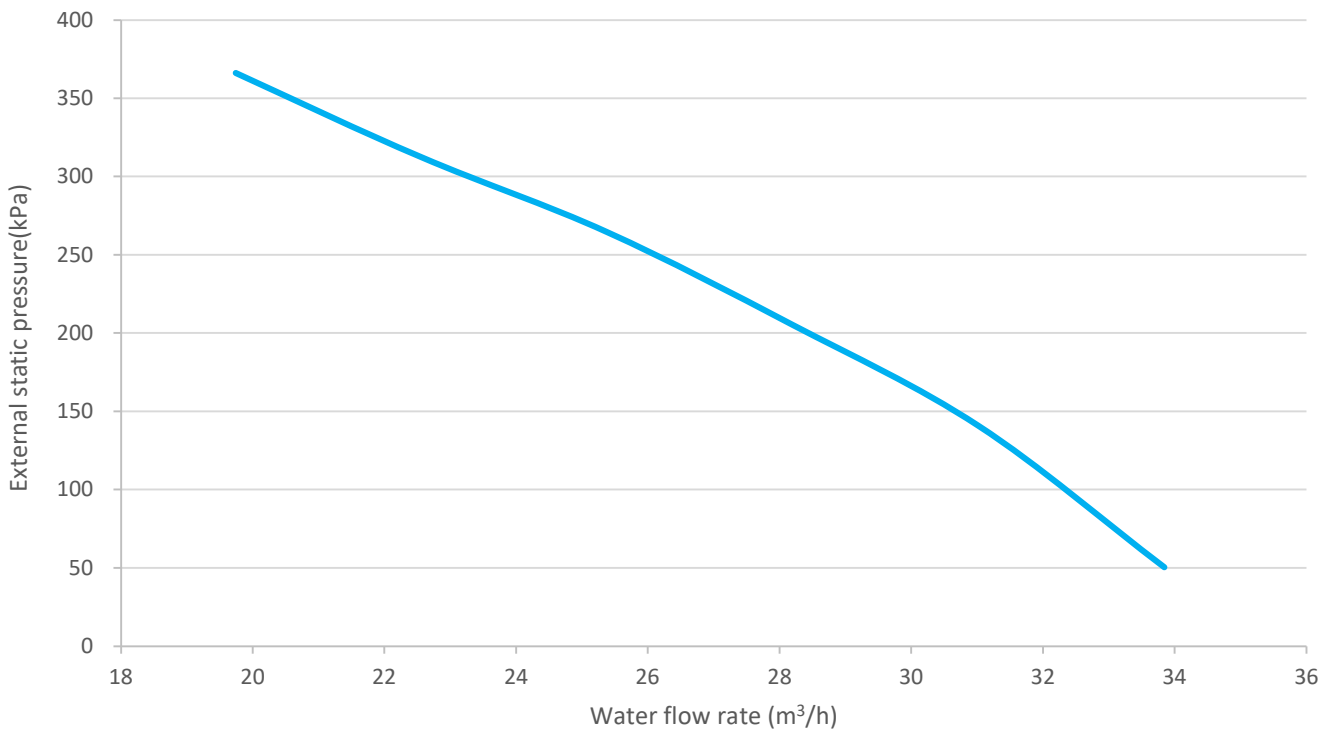

## 8 Octave Band Levels

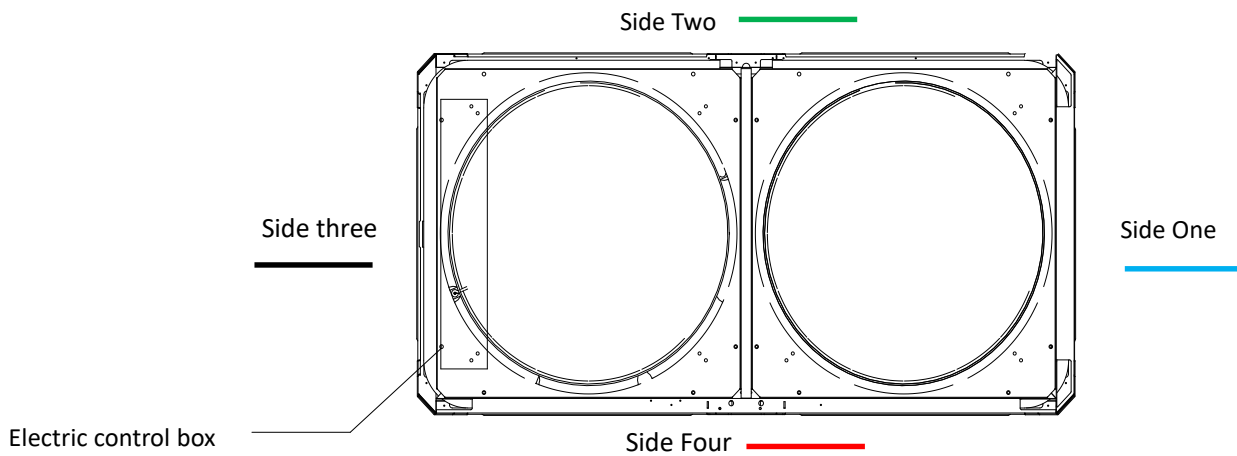

Test condition: Outdoor ambient temperature 35°C DB. EWT 12°C, LWT 7°C

**MUENR-75-H12T**

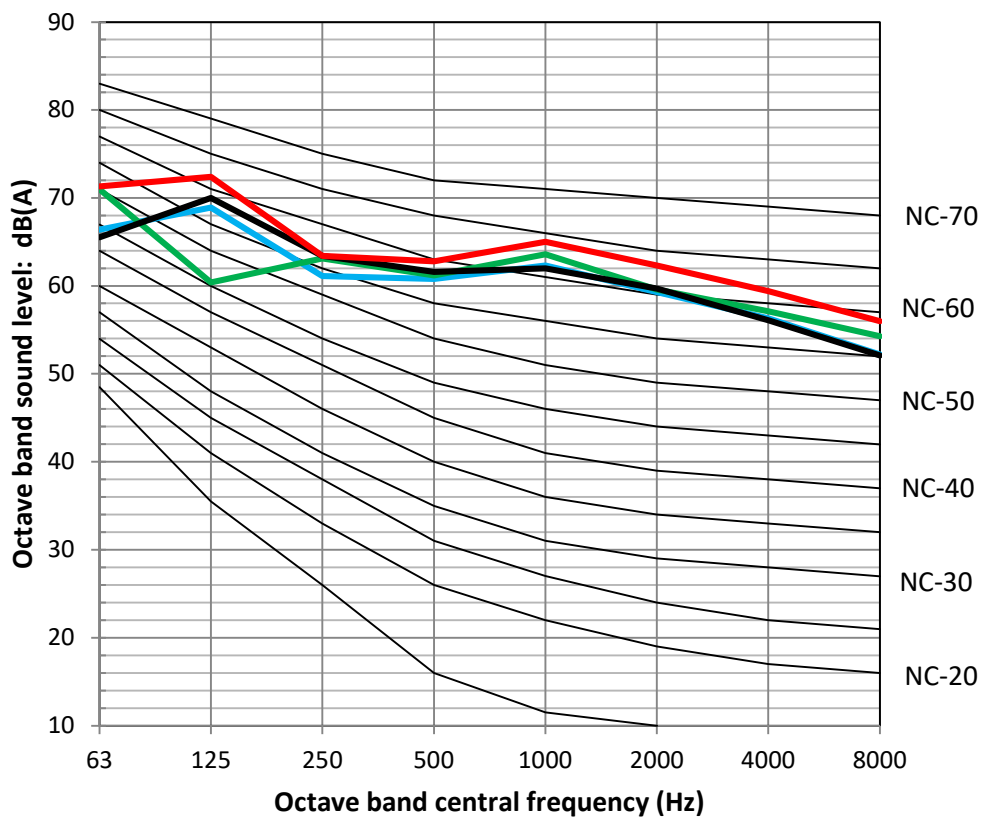

MUENR-75-H12T(K)

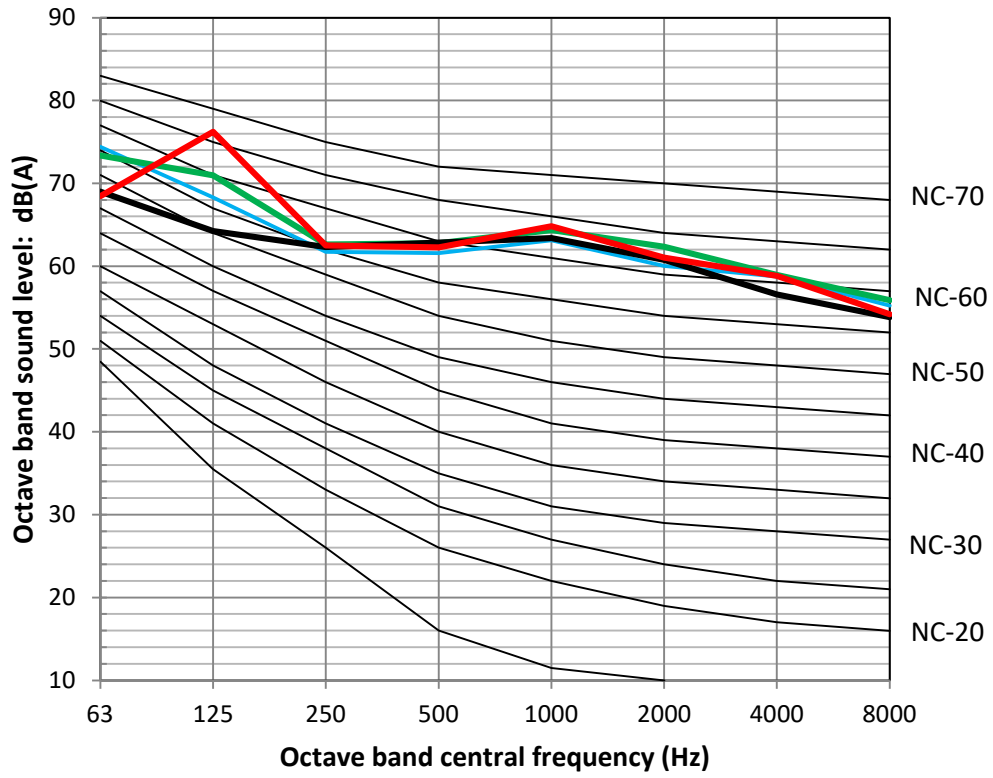

MUENR-90-H12T

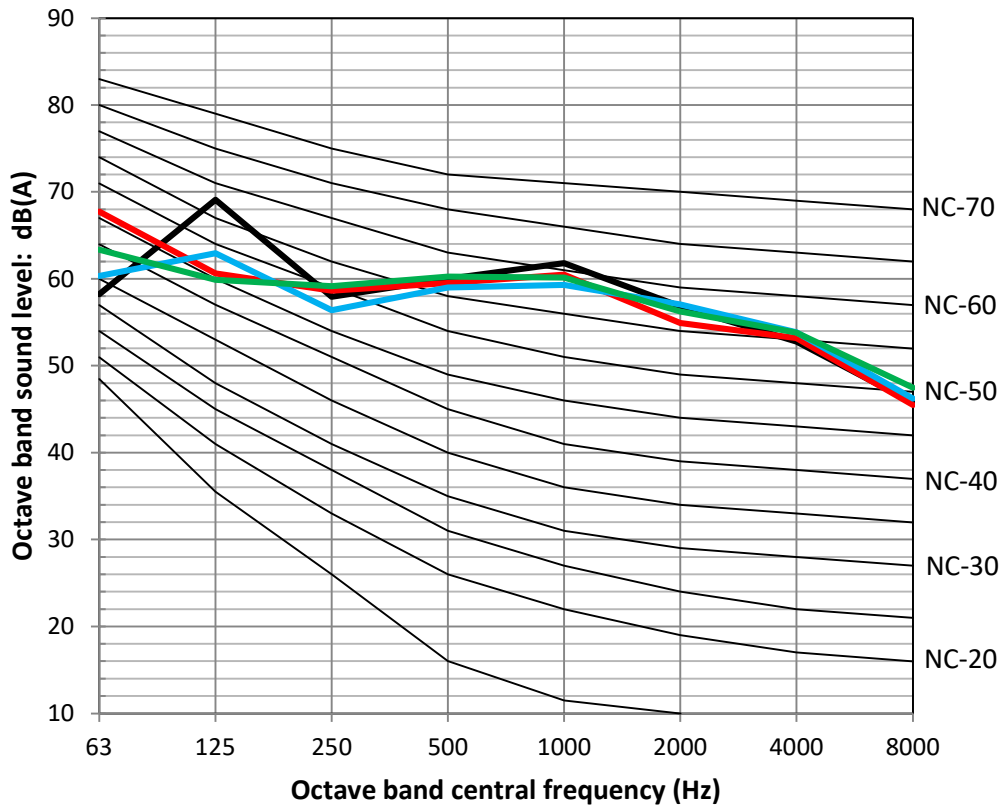

MUENR-90-H12T(K)

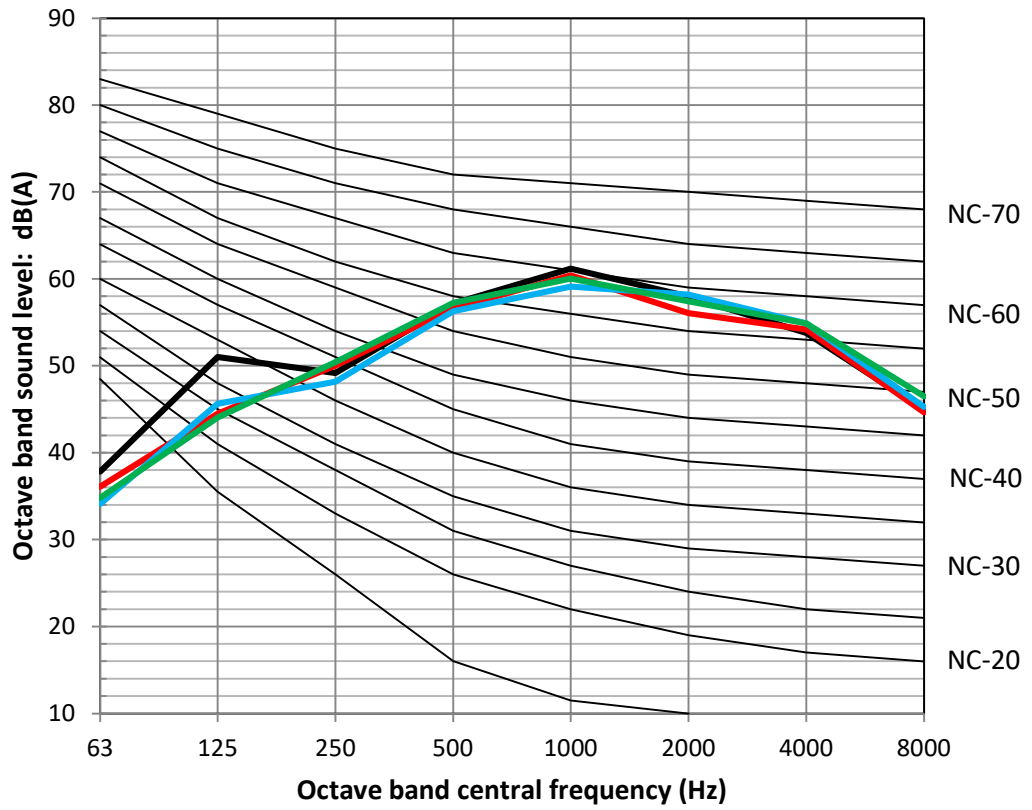

MUENR-140-H12T

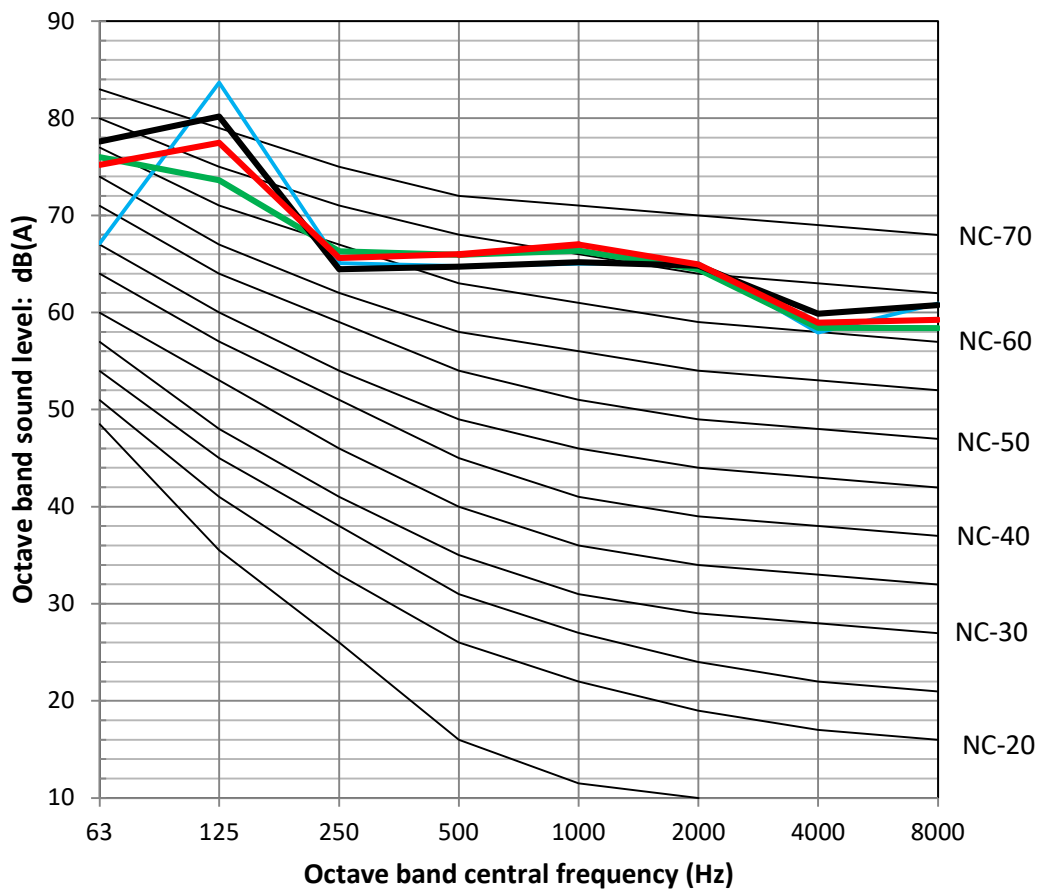

**MUENR-140-H12T  
(K)**

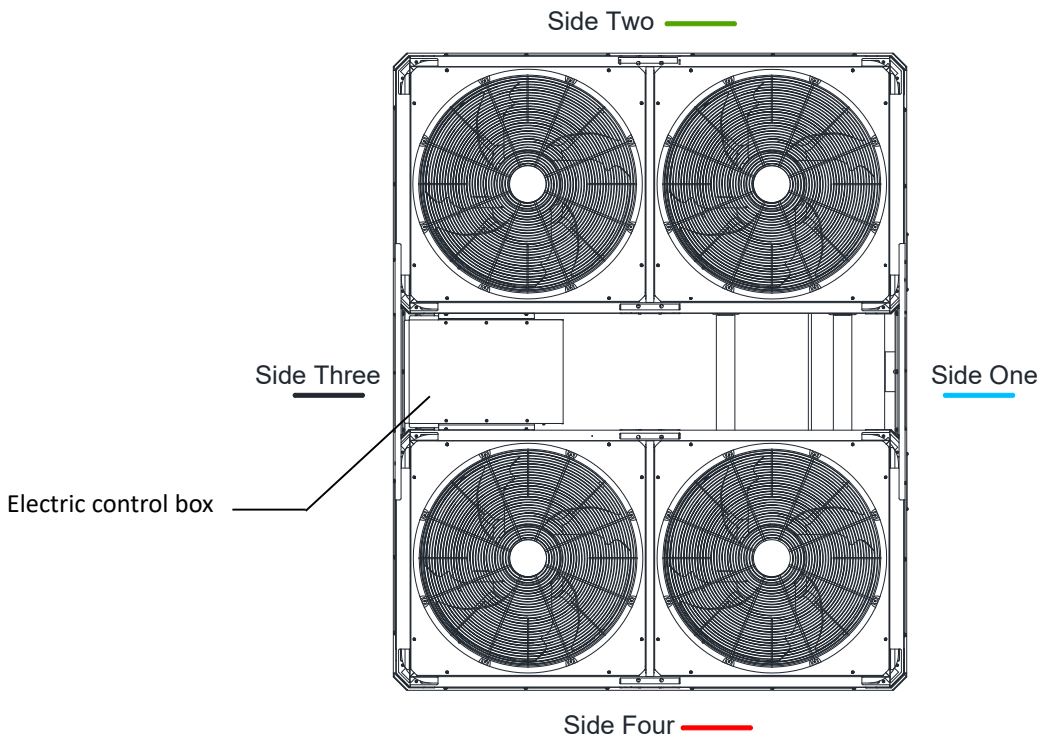
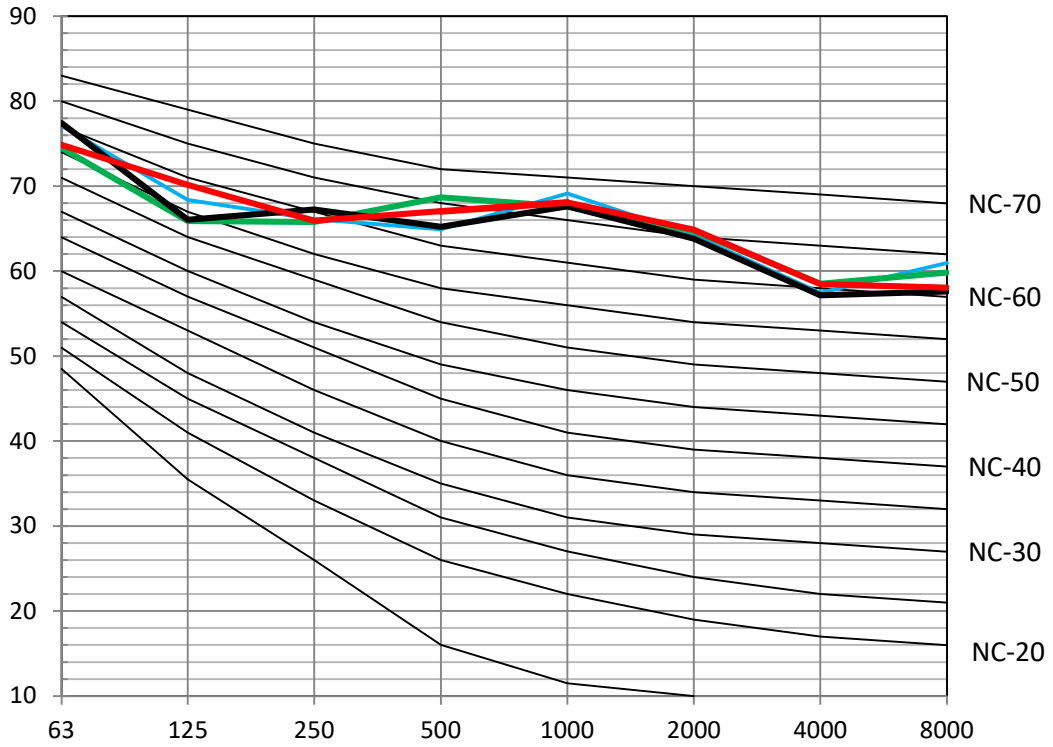

Test condition: Outdoor ambient temperature 35°C DB. EWT 12°C, LWT 7°C

MUENR-180-H12T

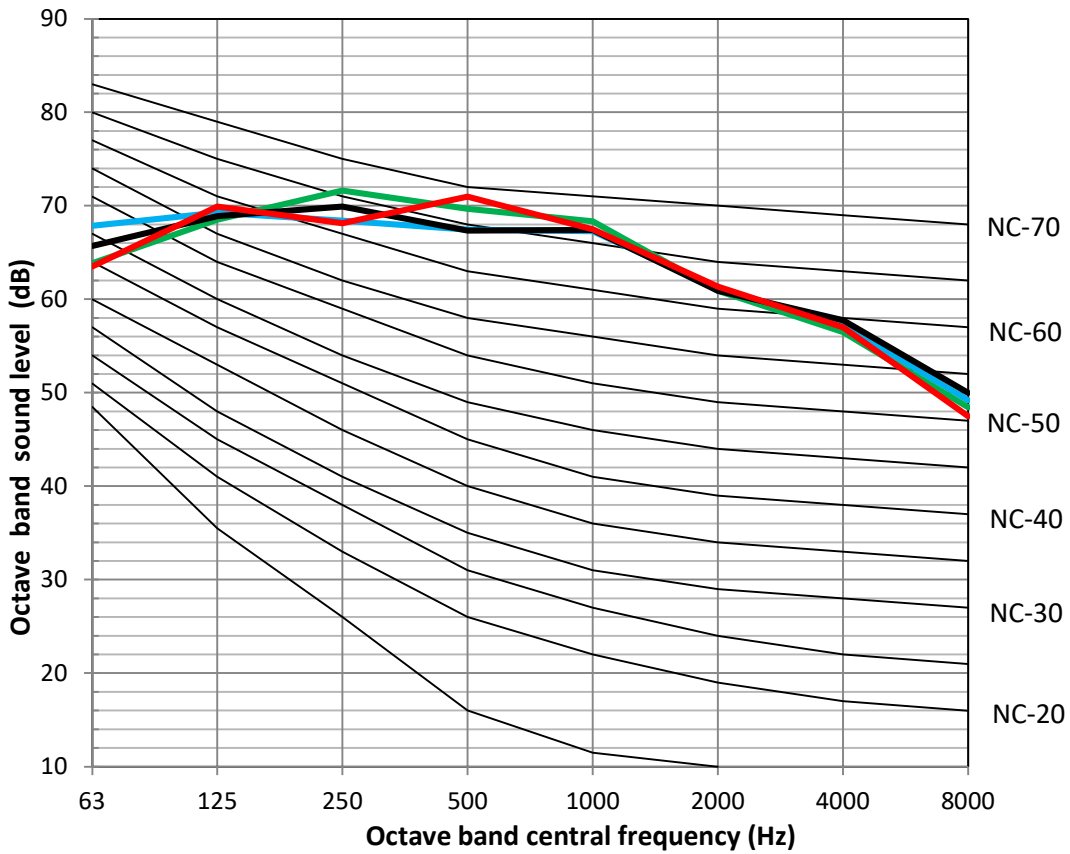

MUENR-180-H12T(K)

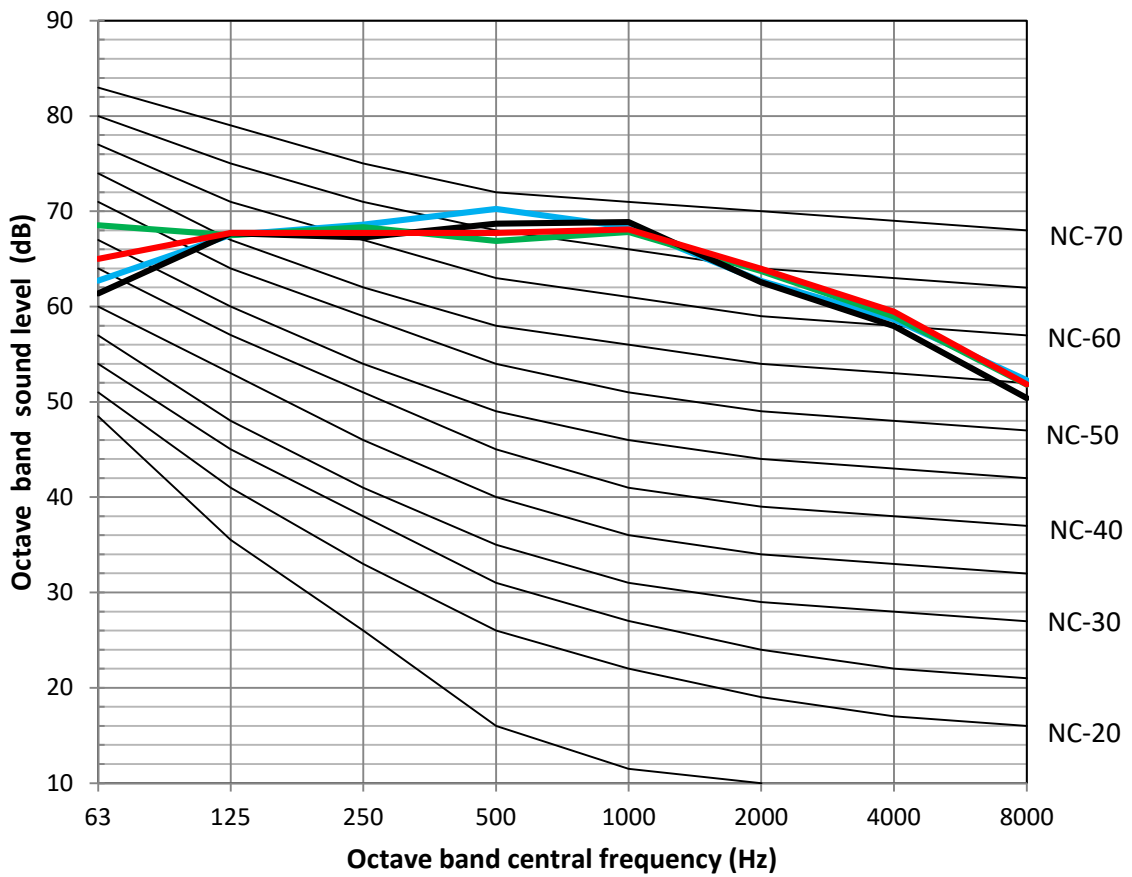

---

# Part 3

## User Interface

### Field Settings

1 User Interface Field Settings.....	49
--------------------------------------	----

## 1 User Interface Field Settings

### 1.1 Introduction

During installation, the unit's settings and parameters should be configured by the installer to suit the installation configuration, climate conditions and end-user preferences. The relevant settings are accessible and programmable through the SERVICE and PROJECT menu on the wired controller's user interface.

KJRM-120H2/BMWKO-E

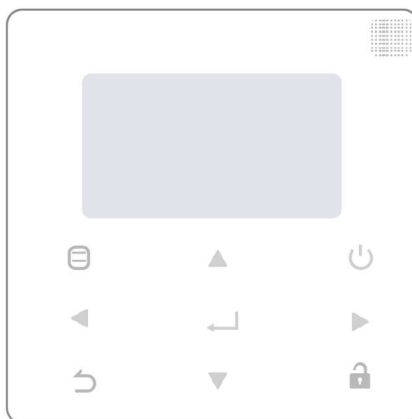

Icon	Function
	Enter the menu structure from the home page
	Navigate the cursor on the display/navigate in the menu structure/ adjust the settings
	Turn on or off the space operation mode
	Come back to the up level
	Long press for unlocking /locking the controller
	Go to the next step when programming a schedule in the menu structure / confirm a selection/enter a submenu in the menu structure

## 1.2 SERVICE MENU

### 1.2.1 Structure

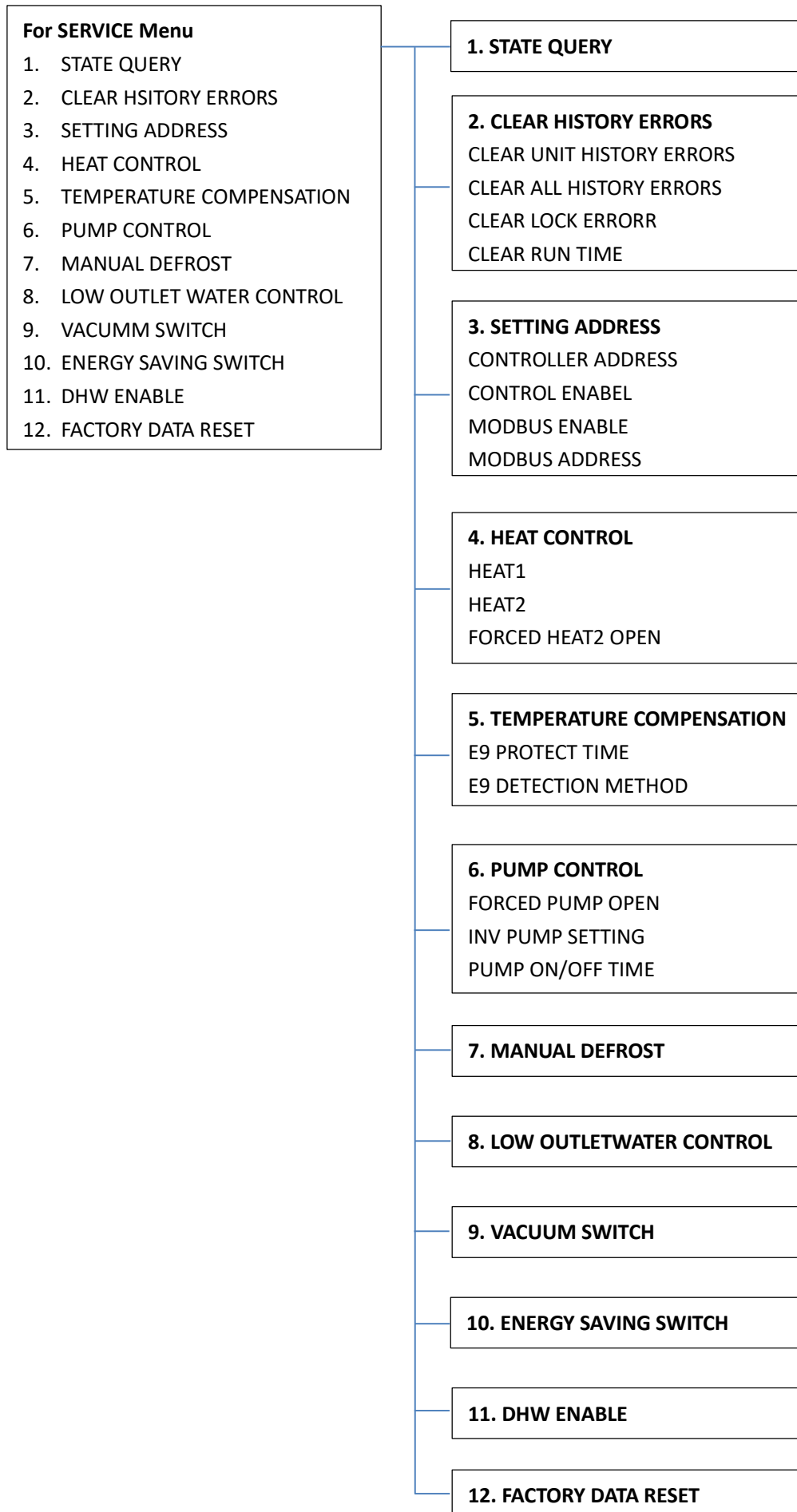

### 1.2.2 Service Menu

#### MENU > Service Menu

Service Menu allows installers to input the system configuration and set the system parameters. Enter the password, using ◀ ▶ to navigate between digits and using ▼ ▲ to adjust the numerical values, and then press ↵. The password is 234.

SERVICE MENU
PLEASE INPUT THE PASSWORD
0 0 0
OK

The following pages will be displayed after putting the password.

SERVICE MENU
STATE QUERY
CLEAR HISTORY ERRORS
SETTING ADDRESS
HEAT CONTROL
OK

1/3

SERVICE MENU
TEMPERATURE COMPENSATION
PUMP CONTROL
MANUAL DEFROST
LOW OUTLET WATER CONTROL
OK

2/3

SERVICE MENU
VACUUM SWITCH
ENERGY SAVING SWITCH
DHW ENABLE
FACTORY DATA RESET
OK

3/3

### 1.2.3 State query

#### MENU > Service Menu > State query

SERVICE MENU
STATE QUERY
CLEAR HISTORY ERRORS
SETTING ADDRESS
HEAT CONTROL
OK

1/3

STATE QUERY allows installers to check the operation parameters. Press ◀ ▶ to select the address of units.

STATE QUERY	
SELECT ADDRESS	◀ 07 ▶ #
ODU MODEL	130 kW
COMP FREQUENCY	50 Hz
COMP1 CURRENT	20 A
COMP2 CURRENT	20 A
BACK	

STATE QUERY	
H-P PRESSURE	3.83 MPa
L-P PRESSURE	1.00 MPa
TP1 DISCHARGE TEMP	30 °C
TP2 DISCHARGE TEMP	30 °C
TH SUCTION TEMP	-20 °C
OK	

2/9

STATE QUERY	
TZ TEMP	-20°C
T3 TEMP	-20°C
T4 TEMP	-20°C
T6A TEMP	40°C
T6B TEMP	40°C
BACK	

3/9

STATE QUERY	
TFIN1 TEMP	60 °C
TFIN2 TEMP	60 °C
TDSH	30 °C
TSSH	15 °C
TCSH	15 °C
BACK	

4/9

STATE QUERY	
FAN1 SPEED	850 RPM
FAN2 SPEED	850 RPM
FAN3 SPEED	850 RPM
EXV A	1800 P
EXV B	1800 P
BACK	

5/9

STATE QUERY	
EXV C	1800P
Tw1 TEMP	30°C
Two TEMP	30°C
Tw TEMP	30°C
TAF1 TEMP	30°C
BACK	

6/9

STATE QUERY	
TAF2 TEMP	30 °C
T5 TEMP	30 °C
COMP TIME1	120 MIN
COMP TIME2	120 MIN
COMP TIME3	120 MIN
BACK	7/9

STATE QUERY	
COMP TIME	65535 H
FIX PUMP TIME	65535 H
INV PUMP TIME	65535 H
ODU SOFTWARE	V45
HMI SOFTWARE	V45
BACK	8/9

STATE QUERY	
DEFROSTING STATE	
00	01
02	03
04	05
06	07
08	09
10	11
12	13
14	15
E2 SOFTWARE V45	
END	
OK	9/9

Note:

1. Tz plate heat exchanger outlet temperature

T3 lowest temperature of condenser tube

T4 ambient temperature

T6A, T6B EVI plate heat exchanger refrigerant temperature

Tfin1, Tfin2 inverter module temperature

TDSH Discharge superheat temperature

TSSH Suction superheat temperature

TCSH Injection superheat temperature

Twi Unit water inlet temperature

Two Unit water outlet temperature

Tw Total water outlet temperature

Taf1 Hot water side antifreeze temperature

Taf2 Water side antifreeze temperature

T5 Water tank temperature

2. For ODU SOFTWARE and HMI SOFTWARE, the version number will vary with product iterations.

1.2.4 Clear history errors

MENU > Service Menu > Clear history errors

SERVICE MENU	
STATE QUERY	
CLEAR HISTORY ERROR	
SETTING ADDRESS	
HEAT CONTROL	
OK	1/3

CLEAR HISTORY ERRORS is used to clear the history error codes and component operation time.

CLEAR UNIT HIS ERRS	
SELECT ADDRESS	◀ 07 ▶
DO YOU WANT TO CLEAR?	◀ YES ▶
OK	↕ ⏪

CLEAR ALL HIS ERRS	
DO YOU WANT TO CLEAR?	◀ YES ▶
OK	⏪



CLEAR LOCK ERR	
DO YOU WANT TO CLEAR?	◀ YES ▶
OK	⏪



CLEAR RUN TIME	
SELECT ADDRESS	◀ 07 ▶
CLEAR COMP TIME?	◀ NO ▶
CLEAR FIX PUMP TIME?	◀ NO ▶
CLEAR INV PUMP TIME?	◀ NO ▶
OK	↕ ⏪

### 1.2.5 Setting address

**MENU > Service Menu > Setting address**

SERVICE MENU
STATE QUERY
CLEAR HISTORY ERROR
<b>SETTING ADDRESS</b>
HEAT CONTROL
OK 1/3

**SETTING ADDRESS** is used to set whether the unit can be controlled by wired controller and through MDOBUS. **SETTING ADDRESS** can also enter by combining buttons pressing ,  for 3s.

CONTROLLER ADDRESS	◀ 10 ▶ #
CONTROL ENABEL	◀ NO ▶
MODBUS ENABLE	◀ NO ▶
MODBUS ADDRESS	◀ 10 ▶ #
OK	 

**CONTROLLER ADDRESS** selects the unit address then we can check the parameters about this unit.

If **CONTROL ENABLE** sets as YES, it means the controller can set all the parameters; if **CONTROL ENABLE** sets as NO, it means the controller can only display the parameters.

If the chiller system access to MODBUS system, **MODBUS ENABLE** should be set as YES. Please note that in this case,

**CONTROL ENABLE** should be also set as YES, otherwise the units cannot be controlled.

**MODBUS ADDRESS** set the controller address if the Modbus system is available.

### 1.2.6 Heat control



**MENU > Service Menu > Heat control**



SERVICE MENU
STATE QUERY
CLEAR HISTORY ERROR
SETTING ADDRESS
<b>HEAT CONTROL</b>
OK 1/3

HEAT CONTROL
HEAT1
HEAT2
FORCED HEAT2 OPEN
OK

**HEAT1** means pipe electric heating in cooling/heating mode.

**HEAT2** means tank electric heating in DHW mode.

HEAT1	
HEAT1 ENABLE	◀ NO ▶
TEMP-	◀ 07 ▶ °C
AUXHEAT1-ON	
TW. HEAT1-ON	◀ 25 ▶ °C
TW. HEAT1-OFF	◀ 45 ▶ °C
OK	1/2  

HEAT2	
ALL HEAT2 DISABLE	◀ YES ▶
SELECT ADDRESS	◀ 10 ▶ #
HEAT2-ENABLE	◀ NO ▶
T-HEAT2-DELAY	◀ 190 ▶ MIN
DT5-HEAT2-OFF	◀ 10 ▶ °C
OK	1/2  

HEAT2							
T4-HEAT2-ON	◀ 10 ▶ °C						
00	01	02	03	04	05	06	07
08	09	10	11	12	13	14	15
OK		2/2	↕ ↔				

FORCED HEAT2 OPEN							
SELECTED ADDRESS	◀ 10 ▶ #						
FORCED HEAT2 OPEN	◀ NO ▶						
00	01	02	03	04	05	06	07
08	09	10	11	12	13	14	15
OK		↕ ↔					

**TEMP-AUXHEAT1-ON** sets the ambient temperature below which the pipe heater (field supplied) turns on.

When the leaving water temperature reaches TW. HEAT1-ON, the pipe electric heater (field supplied) turns on automatically.

When the leaving water temperature reaches TW. HEAT1-OFF, the pipe electric heater (field supplied) turns off automatically.

If the system is installed with tank booster heater, ALL HEAT2 DISABLE should be set as YES.

**HEAT2-ENABLE** sets the state of tank booster heater of SELECT ADDRESS.

**T-HEAT2-DELAY** sets the delay time for tank booster heater to turn on after the compressor starts.

**DT5-HEAT2-OFF** sets the temperature difference between the actual water temperature and setting temperature above which the tank booster heater turns off.

**T4\_HEAT2\_ON** sets the ambient temperature that tank booster heater turns on. (00~15 means unit address)

If **FORCED HEAT2 OPEN** is set as YES, when  $T5 < T5S-1$ , then tank electric heater turns on; when  $T5 \geq T5S$ , then tank electric heater off. (00~15 means unit address)

### 1.2.7 Temperature Compensation

#### MENU > Service Menu > Temperature Compensation

SERVICE MENU				
TEMPERATURE COMPENSATION				
PUMP CONTROL				
MANUAL DEFROST				
LOW OUTLET WATER CONTROL				
OK		2/3	↕	

With the help of **TEMPERATURE COMPENSATION**, water temperature will automatically change as outside air temperature changes. When outdoor air temperature increases/decreases, the heating load will decrease/increase and water temperature will decrease/increase automatically. When outdoor air temperature decreases/increases, the cooling load will decrease/increase and water temperature will increase/decrease automatically.

TEMP COMPENSATION				
COOL MODE ENABLE	◀ YES ▶ °C			
T4 COOL-1	◀ 15 ▶ °C			
T4 COOL-2	◀ 08 ▶ °C			
OFFSET-C	◀ 10 ▶ °C			
OK		1/2	↕ ↔	

TEMP COMPENSATION				
HEAT MODE ENABLE	◀ YES ▶ °C			
T4 HEAT-1	◀ 08 ▶ °C			
T4 HEAT-2	◀ 15 ▶ °C			
OFFSET-H	◀ 10 ▶ °C			
OK		2/2	↕ ↔	

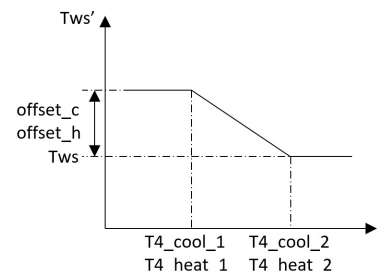

**T4 COOL-1, T4 COOL-2** set the ambient temperature for cooling mode.

**T4 HEAT-1, T4 HEAT-2** set the ambient temperature for heating mode.

**Offset\_c, Offset\_h** is the temperature difference between current water temperature and T4\_cool\_1, T4\_heat\_1 corresponding water temperature.

### 1.2.8 Pump Control

MENU > Service Menu > Pump Control

SERVICE MENU
TMEPERATURE COMPENSATION
<b>PUMP CONTROL</b>
MANUAL DEFROST
LOW OUTLET WATER CONTROL
OK 2/3

PUMP CONTROL
FORCED PUMP OPEN
INV PUMP SETTING
PUMP ON/OFF TIME
OK

FOECED PUMP OPEN
SELECT ADDRESS ◀ 0 ▶ #
FORCED PUMP OPEN ◀ NO ▶
OK

INV PUMP SETTING
SELECT ADDRESS ◀ 07 ▶ #
SWITCH ON THE PUMP ◀ NO ▶
RATIO PUMP ◀ 100 ▶ #
OK

PUMP ON/OFF TIME
PUMP ON TIME ◀ 05 ▶ MIN
PUMP OFF TIME ◀ 05 ▶ MIN
OK

**FORCED PUMP OPEN** is used to control the fixed frequency pump (field supplied) operation.

**INV PUMP SETTING** is used to control the inverter water pump (field supplied) operation, the setting range of RATIO-PUMP is 30%-100%. It should ensure its flow meet the requirement of whole unit, otherwise the unit may be damaged.

**PUMP ON TIME** sets the pump operation time after the unit stops.

If PUMP OFF TIME sets as 0, the pump will run all the time. Otherwise, the pump will operate intermittently according to the PUMP ON TIME and PUMP OFF TIME setting.

	Set range	Default value	Adjustment range
PUMP ON TIME	5~60min	5	5
PUMP OFF TIME	0~60min	0	5

### 1.2.9 Manual Defrost

MENU > Service Menu > Manual Defrost

SERVICE MENU
TMEPERATURE COMPENSATION
PUMP CONTROL
<b>MANUAL DEFROST</b>
LOW OUTLET WATER CONTROL
OK 2/3

MANUAL DEFROST
SELECT ADDRESS ◀ 07 ▶ #
MANUAL DEFRIOST ◀ NO ▶
OK

**MANUAL DEFROST** can force the unit to enter the defrost mode manually.

If the external unit successfully enters the defrost mode after the “MANUAL DEFROST” is turned on, the defrost icon ❄ will be displayed at homepage of the wired controller.

### 1.2.10 Low outlet water temperature control

MENU > Service Menu > Low outlet water temperature control

SERVICE MENU
TEMPERATURE COMPENSATION
PUMP CONTROL
MANUAL DEFROST
<b>LOW OUTLET WATER CONTROL</b>
OK 2/3

At this page, the historical minimum water outlet temperature setting (setting range 0-20°C) can be viewed.

LOW OUTLET WATER CTRL	
MIN TEMP FOR COOL	◀ 50°C ▶
HISTORICAL SETTING	
04/06/2020 11:30A	5°C
04/06/2020 11:30A	5°C
04/06/2020 11:30A	5°C
OK	

**MIN TEMP FOR COOL** sets the lowest water temperature for cooling mode. Please notice that When the setting temperature is less than 5°C, antifreeze liquid should be added in the water system.

LOW OUTLET WATER CONTROL
The setting temp is below 5 degree please confirm whether it is an antifreeze system?
OK

### 1.2.11 Vacuum switch

MENU > Service Menu > Vacuum switch

SERVICE MENU
<b>VACUUM SWITCH</b>
ENERGY SAVING SWITCH
DHW ENABLE
FACTORY DATA RESET
OK 3/3

VACUUM SWITCH	
VACUUM SWITCH	◀ NO ▶
OK	

**VACUUM SWITCH** is used for vacuuming.

### 1.2.12 Energy saving mode

MENU > Service Menu > Energy saving mode

SERVICE MENU
VACUUM SWITCH
<b>ENERGY SAVING SWITCH</b>
DHW ENABLE
FACTORY DATA RESET
OK 3/3

ENERGY SAVING SWITCH	
SAVING SWITCH	◀ 80% ▶
HISTORICAL SETTING	
04/06/2020 11:30A	80%
04/06/2020 11:30A	80%
04/06/2020 11:30A	80%
OK	

For projects with temporary electricity supply restrictions, the outdoor unit supports 7 levels of energy management which

can be set to output 40-100% capacity. It prevents tripping during electricity supply restriction conditions and remains system continue to operate. The historical energy saving switch setting can be viewed.

### 1.2.13 DHW ENABLE

**MENU > Service Menu > DHW ENABLE**

Domestic hot water function can be customized.

DHW ENABLE	
DHW ENABLE	◀ NO ▶
OK	▶◀

### 1.2.14 Factory data reset

**MENU > Service Menu > Factory data reset**

Factory data reset is used to reset all the data to the factory default setting.

FACTORY DATA RESET	
DO YOU WANT TO RESET?	◀ YES ▶
OK	▶◀

## 1.3 PROJECT MENU

### 1.3.1 Structure

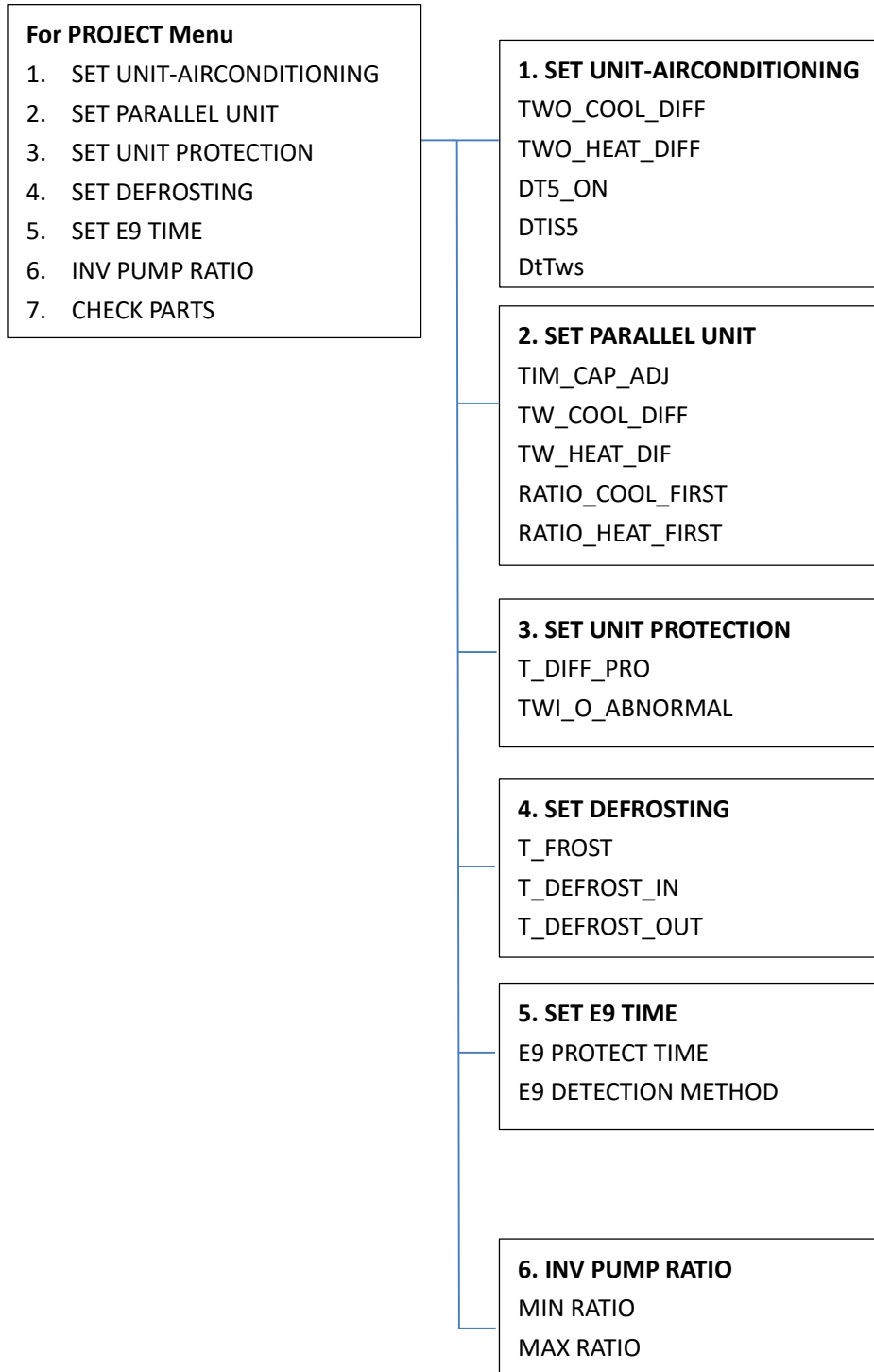

### 1.3.2 Project Menu

#### MENU > Project Menu

Project Menu allows installers to input the system configuration and set the system parameters. Enter the password, using ◀ ▶ to navigate between digits and using ▼ ▲ to adjust the numerical values, and then press **OK**. The password is 9877.

PROJECT MENU
PLEASE INPUT THE PASSWORD
0 0 0 0
<b>OK</b> ▼ ▲

The following pages will be displayed after putting the password.

PROJECT MENU
SET UNIT AIRCONDITIONING
SET PARALLEL UNIT
SET UNIT PROTECTION
SET DEFROSTING
<b>OK</b> 1/2      ▼ ▲

PROJECT MENU
SET E9 TIME
INV PUMP RATIO
CHECK PARTS
<b>OK</b> 2/2      ▼ ▲

### 1.3.3 SET UNIT-AIRCONDITIONING

#### MENU > Project Menu > SET UNIT-AIRCONDITIONING

SET UNIT
TWO_COOL_DIFF      ◀ 2 ▶ °C
TWO_HEAT_DIFF      ◀ 2 ▶ °C
DT5_ON      ◀ 8 ▶ °C
DTIS5      ◀ 10 ▶ °C
DtTws      ◀ 1 ▶ °C
<b>OK</b> ▼ ▲

**TWO\_COOL\_DIFF** sets the minimum temperature difference between the leaving water temperature (Two) and the leaving water set temperature (TwoS) above which the unit will start for cooling mode. When  $Two - TwoS \geq TWO\_COOL\_DIFF$ , unit starts. When  $TwoS - Two \geq 2$  lasts for 5s, unit stops.

**TWO\_HEAT\_DIFF** sets the minimum temperature difference between the leaving water temperature (Two) and the leaving water set temperature (TwoS) above which the unit will start for heating mode. When  $TwoS - Two \geq TWO\_HEAT\_DIFF$ , unit starts. When  $Two - TwoS \geq 2$  lasts for 5s, unit stops.

If unit is customized with the DHW function, when  $TempW\_heat\_Min\_n \leq T5 < \min(T5S, TempW\_heat\_Max\_n) - dt5\_ON$  and  $Two < \min(T5S, TempW\_heat\_Max\_n) - 2$ , then DHW mode is on.

Note:

The value of TempW\_heat\_Min\_n, T5S, TempW\_heat\_Max\_n are related to the ambient temperature, which are already fixed in the program.

T5 means the water tank temperature



T5S means the setting temperature of DHW mode

The target leaving water temperature of DHW mode is  $Twos = T5S + DT1S5$ . If  $Two > TempW\_heat\_Max\_n$ , then DHW mode is off.

DtTws is reserved.

### 1.3.4 SET PARALLEL UNIT

MENU > Project Menu > SET PARALLEL UNIT

SET PAPALLEL UNIT	
TIM_CAP_ADJ	◀ 180 ▶ S
TW_COOL_DIFF	◀ 2 ▶ °C
TW_HEAT_DIFF	◀ 2 ▶ °C
RATIO_COOL_FIRST	◀ 0 ▶ %
RATIO_HEAT_FIRST	◀ 50 ▶ %
OK  	

**TIM\_CAP\_ADJ** sets the period of capacity adjustment

**TW\_COOL\_DIFF** sets the minimum temperature difference between the total leaving water temperature ( $T_w$ ) and the total leaving water set temperature ( $T_wS$ ) above which the unit will start for cooling mode. When  $T_w - T_wS \geq TW\_COOL\_DIFF + 1$ , unit starts. When  $T_wS - T_w \geq 2$  lasts for 5s, unit stops.



**TW\_HEAT\_DIFF** sets the minimum temperature difference between the total leaving water temperature ( $T_w$ ) and the total leaving water set temperature ( $T_wS$ ) above which the unit will start for heating mode. When  $T_wS - T_w \geq TW\_HEAT\_DIFF + 1$ , unit starts. When  $T_w - T_wS \geq 1$  lasts for 5s, unit stops.

**RATIO\_COOL\_FIRST** sets the number of initial startup units for cooling mode.

**RATIO\_HEAT\_FIRST** sets the number of initial startup units for heating mode.

### 1.3.5 SET UNIT PROTECTION

MENU > Project Menu > SET UNIT PROTECTION

SET UNIT PROTECTION	
T_DIFF_PRO	◀ 12 ▶ °C
TWI_O_ABNORMAL	◀ 2 ▶ °C
OK  	

**T\_DIFF\_PRO** set the absolute difference between entering water temperature ( $T_{wi}$ ) and leaving water temperature ( $T_{wo}$ ). If  $|T_{wi} - T_{wo}| \geq T\_DIFF\_PRO$ , unit stops and error code P9 appears. When  $|T_{wi} - T_{wo}| \leq 6$ , error code disappears.

**TWI\_O\_ABNORMAL** sets the difference between Inlet water temperature ( $T_{wi}$ ) and Outlet water temperature ( $T_{wo}$ ). For cooling mode, if  $T_{wo} - T_{wi} \geq TWI\_O\_ABNORMAL$  and lasts for 20min, unit stops and error code PA appears. If  $T_{wo} - T_{wi} \leq TWI\_O\_ABNORMAL - 1$ , error code disappears. For heating mode, if  $T_{wi} - T_{wo} \geq TWI\_O\_ABNORMAL$  and lasts for 20min, unit stops and error code PA appears. If  $T_{wi} - T_{wo} \leq TWI\_O\_ABNORMAL - 1$ , error code disappears.

### 1.3.6 SET DEFROSTING

MENU > Project Menu > SET DEFROSTING

SET DEFROSTING	
T_FROST	◀ 35 ▶ min
T_DEFROST_IN	◀ 0 ▶ °C
T_FROST_OUT	◀ 0 ▶ °C
OK	⬆ ⬇ ⬅

**T\_FROST** sets the time between the end of the last defrost mode and the beginning of the next defrost mode.

**T\_DEFROST\_IN** sets the temperature for T3 of entering defrosting mode. When T3 reaches T\_DEFROST\_IN, unit enters defrosting mode.

**T\_FROST\_OUT** sets the temperature for T3 of exiting defrosting model. When T3 reaches T\_DEFROST\_OUT, unit exits defrosting mode.

### 1.3.7 DHW time setting (Customized)

MENU > Project Menu > SET DHW TIME

SET DHW TIME	
SELECT ADDRESS	◀ 07 ▶ #
COOL MAX TIME	◀ 08 ▶ h
COOL MIN TIME	◀ 0.5 ▶ h
HEAT MAX TIME	◀ 08 ▶ h
HEAT MIN TIME	◀ 0.5 ▶ h
OK	1/2 ⬆ ⬇ ⬅

SET DHW TIME	
DHW MIN TIME	◀ 0.5 ▶ h
DHW MAX TIME	◀ 08 ▶ h
OK	2/2 ⬆ ⬇ ⬅

**COOL MAX TIME** sets the maximum operation time for cooling mode when DHW requirement exists.

**COOL MIN TIME** sets the minimum operation time for cooling mode when DHW requirement exists.

**HEAT MAX TIME** sets the maximum operation time for heating mode when DHW requirement exists.

**HEAT MIN TIME** sets the minimum operation time for heating mode when DHW requirement exists.

**DHW MIN TIME** sets the minimum operation time for DHW mode.

**DHW MAX TIME** sets the maximum operation time for DHW mode.

### 1.3.8 SET E9 TIME

MENU > Project Menu > SET E9 TIME

SET E9 TIME	
E9 PROTECT TIME	◀ 10 ▶ S
E9 DETECTION METHOD	◀ 1 ▶ #
OK	⬆ ⬇ ⬅

**E9 PROTECT TIME** sets the delay time of water flow detection. When unit starts, water flow will not be detected until at least (2+ E9 PROTECT TIME/60) minutes have elapsed.

**E9 DETECTION METHOD** sets the method of water flow detection. If "1" is selected, the water flow switch is detected after

water pump starts. If “2” is selected, the water flow switch is both detected before and after the water pump starts.

### 1.3.9 INV PUMP RATIO

MENU > Project Menu > INV PUMP RATIO

INV PUMP RATIO	
MIN RATIO	◀ 70 ▶ %
MAX RATIO	◀ 100 ▶ %
OK	⬇ ⬅

**MIN RATIO** sets the minimum output ratio of inverter pump which is installed in the main water pipe.

**MAX RATIO** sets the maximum output ratio of inverter pump which is installed in the main water pipe.

### 1.3.10 CHECK PARTS

MENU > Project Menu > CHECK PARTS

State of different parts can be checked in this menu.

CHECK PARTS	
SELECT ADDRESS	◀ 07 ▶ #
FIX PUMP STATE	OFF
INV PUMP STATE	80%
FOUR-WAY VALVE	OFF
SV1 STATE	OFF
BACK	1/3 ⬇ ⬅

CHECK PARTS	
SV2 STATE	OFF
SV4 STATE	OFF
SV5 STATE	OFF
SV6 STATE	OFF
SV8A STATE	OFF
BACK	2/3 ⬇ ⬅

CHECK PARTS	
SV8B STATE	OFF
HEAT1 STATE	OFF
HEAT2 STATE	OFF
COIL VALVE	OFF
BACK	3/3 ⬇ ⬅

## 1.4 Parameters setting

Menu	Parameters	Setting range	Default value	Adjustment range
Service menu	TEMP_AUXHEAT_ON	0~10°C	5°C	1°C
	TW_HEAT1_ON	0~50°C	25°C	1°C
	TW_HEAT1_OFF	0~50°C	45°C	1°C
	T_HEAT2_DELAY	60~240min	90min	5min
	DT5_HEAT2_OFF	2~10°C	5°C	1°C
	T4_HEAT2_ON	-5~20°C	5°C	1°C
	T4_COOL_1	15~30°C	25°C	1°C
	T4_COOL_2	35~45°C	40°C	1°C
	OFFSET_C	0~15°C	10°C	1°C
	T4_HEAT_1	-10~10°C	2°C	1°C
	T4_HEAT_2	15~30°C	15°C	1°C
	OFFSET_H	0~30°C	10°C	1°C
	RATIO_PUMP	30%~100%	100%	5%
	PUMP ON TIME	5~60min	5min	5min
	PUMP OFF TIME	0~60min	0min	5min
	MIN TEMP FOR COOL	0~20°C	7°C	1°C
	ENERGY SAVING SWITCH	40~100%	100%	10%

Menu	Parameters	Setting range	Default value	Adjustment range	
Project menu	TWO_COOL_DIFF	1°C~5°C	2°C	1°C	
	TWO_HEAT_DIFF	1°C~5°C	2°C	1°C	
	TIM_CAP_ADJ	60~360s	80s	20s	
	TW_COOL_DIFF	1°C~5°C	2°C	1°C	
	TW_HEAT_DIFF	1°C~5°C	2°C	1°C	
	RATIO_COOL_FIRST	0~100%	50%	5%	
	RATIO_HEAT_FIRST	0~100%	50%	5%	
	T_DIFF_PRO	8~15°C	12°C	1°C	
	TWI_O_ABNORMAL	1~5°C	2°C	1°C	
	T_FROST	20~120 min	35 min	5min	
	T_DEFROST_IN	-5~5°C	0°C	1°C	
	T_FROST_OUT	-10~+10°C	0°C	1°C	
	E9 PROTECT TIME	2~20s	5s	1	
	E9 DETECTION METHOD	1~2	1	1	
	MIN RATIO	40~100%	75%	5%	
	MAX RATIO	70~100%	100%	5%	
	Project menu (customized with DHW)	dT5_ON	2~10°C	8°C	1°C
		dT1S5	5~20°C	10°C	1°C
COOL MIN TIME		0.5~24h	0.5h	0.5h	
COOL MAX TIME		0.5~24h	8h	0.5h	
HEAT MIN TIME		0.5~24h	0.5h	0.5h	
HEAT MAX TIME		0.5~24h	8h	0.5h	

MUNDO  CLIMA®



SALVADOR ESCODA S.A.U.  
C/ ROSELLÓ 430-432  
08025 BARCELONA  
ESPAÑA / SPAIN  
(+34) 93 446 27 80  
SAT: (+34) 93 652 53 57