

MEDIUM PRESSURE DUCT FANCOIL
MUCM-W9 Series



MUNDOCLIMA®



FEATURES

- Low noise and low-energy consumption DC fan motor.
- Battery of 3 rows.
- Removable air filter from both side and bottom/top.
- Configurable static pressure through the micro-switches of the PCB.
- ON/OFF port.
- Alarm output.
- Conventional thermostat connection (3 speed)

- Hydraulic connections on the right side (front view), with the possibility of changing to the left side.
- Change of the suction direction from the rear side to the lower side.
- Remote control not included.

With the optional extension module (CL09422):

- 0-10 V input for speed selection.
- 0-10 V (24 V) output for proportional valve control.
- Input for winter/summer selection.

OPTIONALS

More information on the optionals in "MUNDOCLIMA CONTROL SYSTEMS"

Wired remote control

Accessories



WDC-86E/KD⁽¹⁾
(CL09208)



TFDS2T
(CO14210)



Extension module
(CL09422)



Actuator Valve
(CO12231)



3-way valves with bypass
(CO12151)



Set of valve connection tubes
(CL09409)

(1) It is necessary to configure the room temperature sensor reading on the wired control.

SPECIFICATIONS

Model		MUCM-09-W9	MUCM- 12-W9	MUCM- 15-W9	MUCM-19-W9	MUCM-27-W9	MUCM-30-W9	MUCM-36-W9		
Code		CL04650	CL04651	CL04652	CL04653	CL04654	CL04655	CL04656		
Cooling	Capacity (H / M / L) ⁽¹⁾	kW	2.45 / 2.05 / 1.59	3.35 / 2.89 / 2.21	4.55 / 3.92 / 2.97	5.85 / 4.88 / 3.66	8.02 / 6.65 / 5.37	10.08 / 7.25 / 6.02	11.11 / 10.58 / 9.77	
	Water flow rate (H / M / L)	m ³ /h	0.41 / 0.35 / 0.28	0.59 / 0.49 / 0.37	0.80 / 0.67 / 0.54	1.00 / 0.84 / 0.65	1.36 / 1.17 / 0.94	1.69 / 1.44 / 1.16	2.02 / 1.84 / 1.71	
	Pressure drop (H / M / L)	kPa	17.0 / 13.7 / 13.0	23.0 / 17.6 / 10.6	23.0 / 19.0 / 12.1	34.0 / 26.5 / 16.9	32.0 / 26.1 / 18.1	27.0 / 20.07 / 14.0	33.0 / 29.3 / 25.9	
Heating	45 °C	Capacity (H / M / L) ⁽²⁾	kW	2.68 / 2.24 / 1.83	3.95 / 3.25 / 2.51	5.50 / 4.38 / 3.20	6.90 / 5.66 / 4.21	9.40 / 7.36 / 5.82	11.83 / 8.32 / 6.78	12.67 / 11.98 / 10.59
		Water flow rate (H / M / L)	m ³ /h	0.45 / 0.38 / 0.33	0.67 / 0.55 / 0.42	0.92 / 0.76 / 0.59	1.16 / 0.96 / 0.75	1.53 / 1.26 / 0.98	1.94 / 1.64 / 1.30	2.23 / 2.04 / 1.84
		Pressure drop (H / M / L)	kPa	17.0 / 13.1 / 11.9	25.0 / 18.1 / 11.2	25.0 / 19.9 / 12.0	38.0 / 28.7 / 18.6	41.0 / 25.3 / 16.4	26.0 / 20.1 / 13.3	34.0 / 30.4 / 25.3
	50 °C	Capacity (A / M / B) ⁽³⁾	kW	3.16 / 2.68 / 2.16	4.64 / 3.85 / 2.97	6.20 / 5.14 / 3.74	7.70 / 6.22 / 4.50	10.45 / 8.83 / 7.11	13.22 / 9.81 / 7.96	15.38 / 14.95 / 13.45
		Water flow rate (H / M / L)	m ³ /h	0.54 / 0.46 / 0.37	0.80 / 0.66 / 0.51	1.07 / 0.88 / 0.64	1.32 / 1.07 / 0.77	1.79 / 1.51 / 1.22	2.27 / 1.68 / 1.36	2.64 / 2.57 / 2.31
		Pressure drop (H / M / L)	kPa	15 / 11.2 / 10.79	20.2 / 14.5 / 8.8	15.80 / 10.07 / 3.13	30.3 / 22.3 / 14.3	28.31 / 21.67 / 15.0	20.84 / 15.66 / 10.60	29.49 / 27.15 / 22.40
Air flow (H / M / L) ⁽⁴⁾		m ³ /h	374 / 301 / 228	550 / 421 / 307	800 / 622 / 456	1022 / 810 / 552	1400 / 1082 / 816	1750 / 1222 / 912	2250 / 1952 / 1675	
Static pressure		Pa	50 Pa (default); 12 / 30 Pa can be adjusted using the micro-switches of the PCB.							
Power supply		V/Ph/Hz	220-240 / 1 / 50							
Consumption (High)		W	17	23	40	65	70	119	119	
Sound pressure (H / M / L) ⁽⁵⁾		dB (A)	39 / 33 / 25	37 / 31 / 22.5	45 / 39 / 31	49.5 / 43.5 / 34	49.5 / 43 / 36	49.5 / 42.5 / 33.5	53 / 50 / 46.5	
Max. working pressure		MPa	1.6	1.6	1.6	1.6	1.6	1.6	1.6	
Inlet water maximum temperature		°C	80	80	80	80	80	80	80	
Water connections (female)		inch	3/4"	3/4"	3/4"	3/4"	3/4"	3/4"	3/4"	
Drainage connections (male)		inch	3/4"	3/4"	3/4"	3/4"	3/4"	3/4"	3/4"	
Dimensions (Width x Height x Depth)		mm	632 x 243 x 482	773 x 243 x 482	908 x 243 x 482	1003 x 243 x 482	1368 x 243 x 482	1658 x 243 x 482	1898 x 243 x 482	
Weight		kg	14.0	17.2	23.0	24.5	27.7	33.8	37.0	

- Notes:**
- (1) Cooling capacity for each of the three air flow rates and according to the conditions: Water inlet/outlet temp. 7/12 °C, Ambient temp. 27 °C DB, 19 °C WB.
 - (2) Heating capacity for each of the three air flow rates and according to the conditions: Water inlet/outlet temp. 45/40 °C, Ambient temp. 20 °C DB.
 - (3) Heating capacity for each of the three air flow rates and according to the conditions: Water inlet/outlet temp. 50 °C/* Ambient temp. 20 °C DB.
 - (4) Nominal air flow at 0 Pa.
 - (5) Sound pressure level for 0 Pa measured in semi-anechoic chamber.

- The above design and specifications are subject to changes due to product improvement without prior notice.

DIMENSIONS

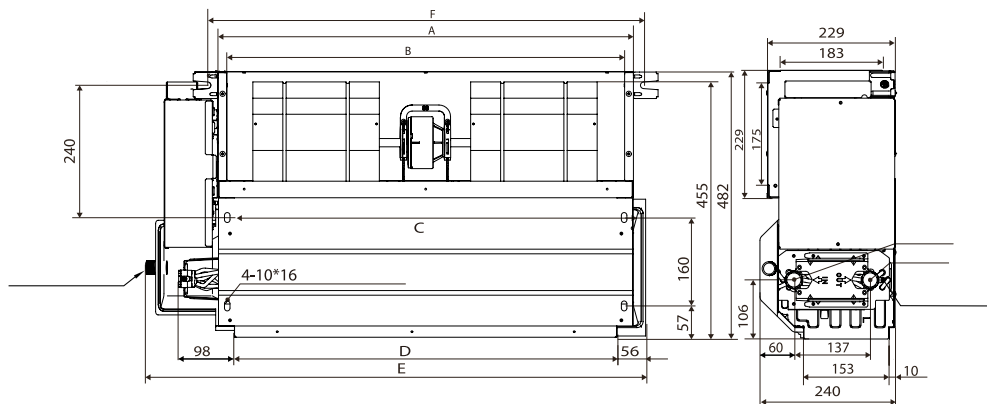

Model	9	12	15	19	27	30	36
A (mm)	475	620	755	850	1215	1505	1745
B (mm)	443	588	723	818	1183	1473	1713
C (mm)	443	588	723	818	1183	1473	1713
D (mm)	415	560	695	790	1155	1445	1685
E (mm)	627	772	907	1002	1367	1657	1897
F (mm)	513	658	793	888	1253	1543	1783