

# CENTRIFUGAL PUMP WITH TANK

## Mod. SE300/4



- Alarm control 4 Amp.
- Includes 1/4" return valve
- Max. flow rate: 300 l/h
- Suitable for floor-ceiling, cassette and duct equipment, cooling cabinets, evaporators and condensing boilers >2.5 PH.



### DIMENSIONS:

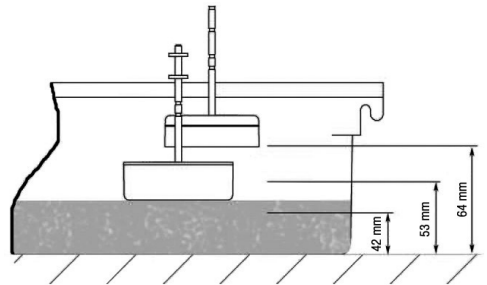
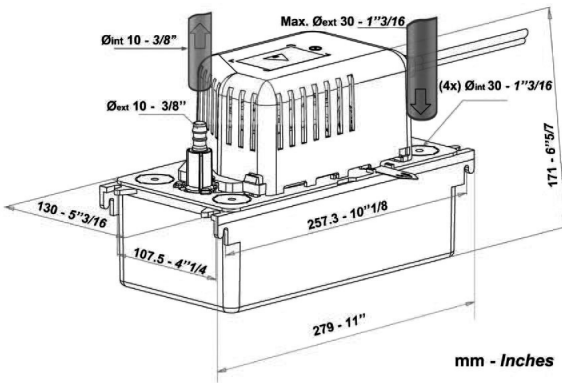

Detection levels

Code	Model	Voltage	Consumption	Max. height	Sound level	Diameter	Max. temp.	Tank
AS 06 840	SE 300/4	230V-50Hz	70W	5 meters	45 dB	Ø10	65/80°C	2 l

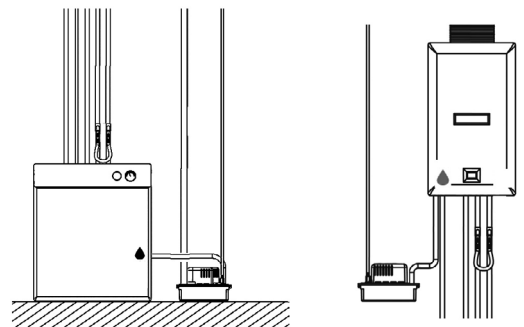
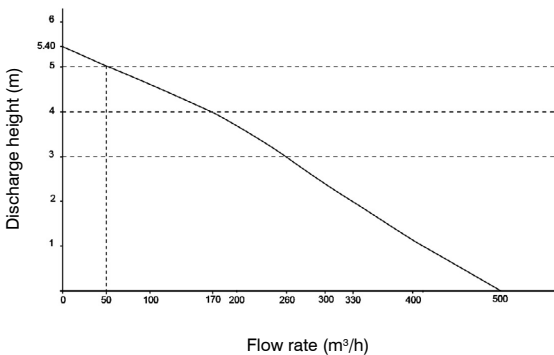

Hydraulic connections