

MODEL: EASY AQUA CODE: AS06806

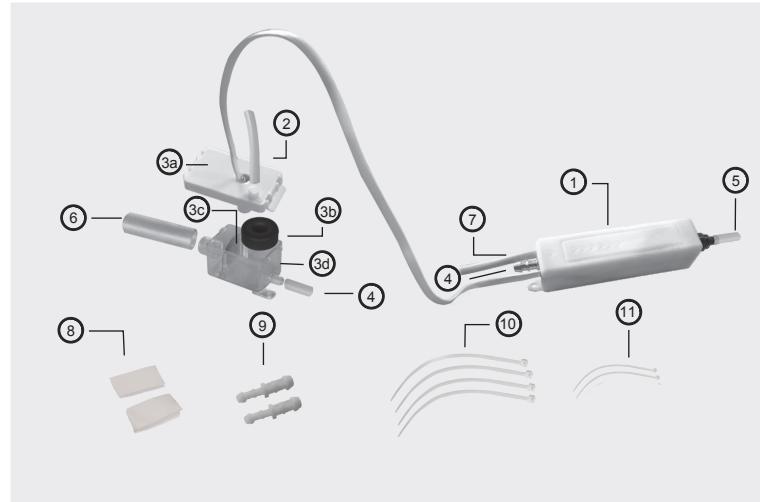

Thank you for buying our new condensate pump of EASY AQUA. This manual gives instructions on the correct installation. Please record the following information for your future reference.

In the box



- ① Assembled slim box
- ② 6mm i/d vinyl tube
- ③ Assembled Inline reservoir, including:
 - ③a lid & sensor cable
 - ③b float
 - ③c filter
 - ③d reservoir
- ④ 1.5m length of 6mm i/d vinyl tube
- ⑤ 20cm length of 4mm i/d vinyl tube
- ⑥ Inlet tube
- ⑦ Power cable
- ⑧ 2 x self adhesive velcro strips
- ⑨ 2 x adapters
- ⑩ 4 x 200mm x 5mm cable ties
- ⑪ 2 x 100mm x 3mm cable ties

***NOTE:**
You will need several metres of 9mm o/d x 6mm i/d vinyl tube.

Technical Data

- Power supply : 230V AC 50/60Hz
- Max.flow: 15L/h @ 0 head
- Sound level: <19dB(A) @ 1m
- Max.recommended head: 12m
- Max.suction lift: 2m
- Max.unit output: 16kw / 54600 Btu/h
- Safety switch: 3A Normally closed
- Max.water temperature: 40°C
- Discharge tube: 6mmID
- Class: II appliance
- Rated: Non continuous
- IP Protection: IPX5
- Thermal protection: ✓
- Fully potted: ✓
- L×W×H: 150mm×29mm×29mm
- CE marked

Product Safety

- CAUTION: The EASY AQUA. Pump has been evaluated for use with water only.
- WARNING: Risk of electric shock. This pump has not been investigated for use in swimming pool or marine areas.
- The means for isolation must be incorporated in the fixed wiring in accordance with wiring regulations.
- Ensure the pump is disconnected from the mains supply before carrying out any adjustments or servicing.
- The supply cord can not be replaced. If the cord is damaged, this pump must be discarded.
- Do not run this pump dry.
- Always ensure the metal magnet in the float is facing upwards.
- Always ensure the reservoir is sitting flat and horizontal.
- The Pump is ideal for most working and living environments. It is not recommended where the environment is oily or particularly dusty.
- Acceptable for indoor use only.
- Non-submersible pump.

Typical Performance

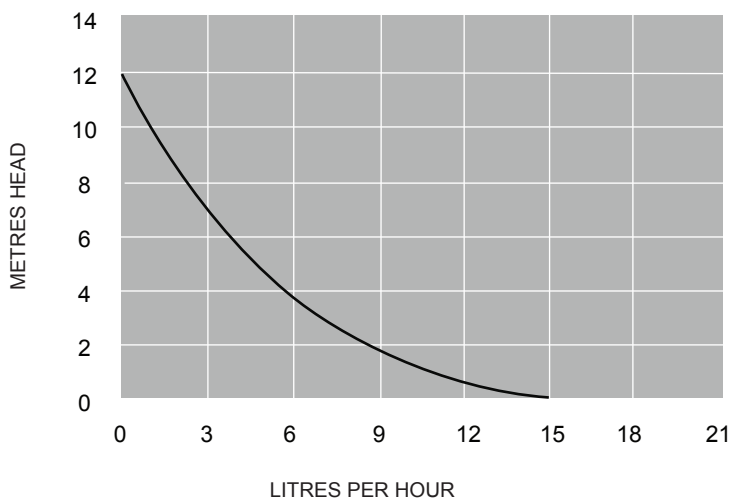

Installation

1. Ensure float is positioned in reservoir with magnet uppermost, the filter is in place and the lid is clipped firmly onto reservoir.

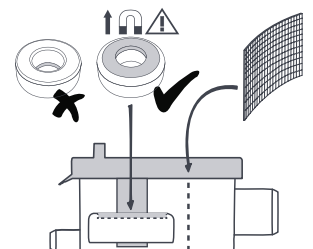

2. Secure reservoir horizontally using velcro strips and for the inline reservoir use the inlet hose to connect firmly to drainage pipe.

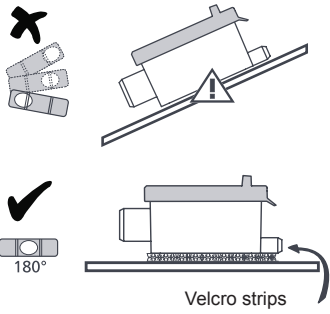

3. Fit breather tube to reservoir lid.

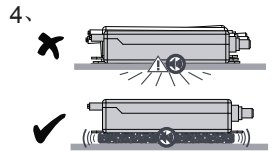
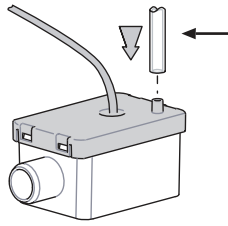

6. Note direction of water flow

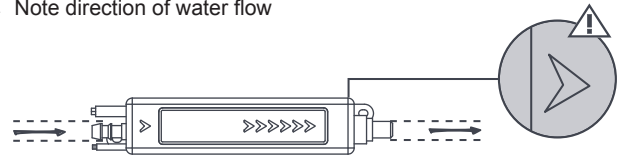

7. Push the 9mm o/d x 6mm i/d tube onto the reservoir and the pump. Secure with cableties. Ensure length is under 2 metres.

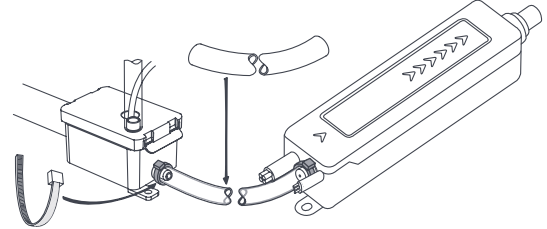

5. Install pump drive unit above the ceiling where possible.

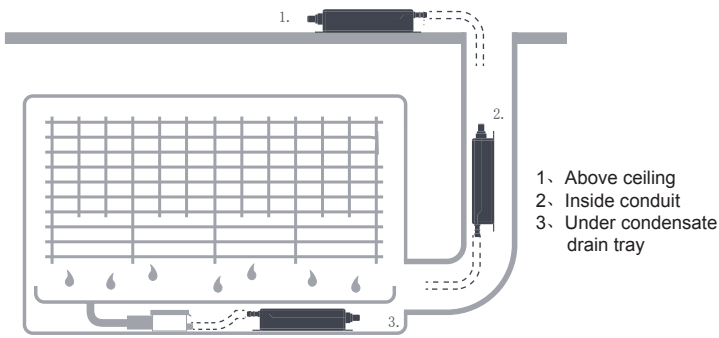

1. Above ceiling
2. Inside conduit
3. Under condensate drain tray

8. Connect your 9mm o/d x 6mm i/d vinyl discharge tube to the outlet barb on the pump and secure with a cable tie.

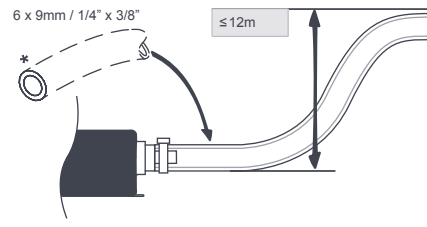

9. Channel discharge tube to an appropriate drain, avoiding restrictions

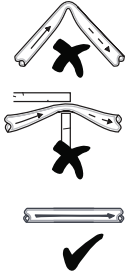

10. A high-level alarm switch should be wired into the cooling signal wire, to prevent the continued operation of the air conditioning unit in the event of the pump failing.

IMPORTANT: This diagram is an example of how the pump could be installed and is therefore for reference only. All pump units must be installed by qualified engineers, who have assessed the set-up of the individual a/c unit.

(1) Signal-line connection

(2) Strong electric control connection (Current <math>< 3A</math>)

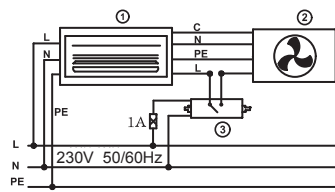
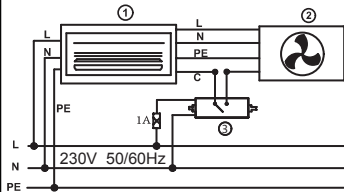

(3) Strong electric control connection (Current >math>> 3A</math>)

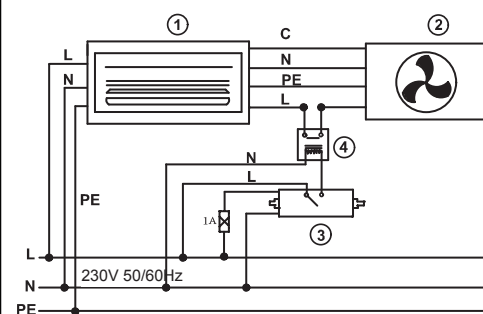

- ① Indoor unit
- ② Outdoor
- ③ Pump unit
- ④ Contactor Relay (Normally Open)

Servicing

- This Pump, like all mechanical equipment, requires maintenance.
- Every six months the reservoir should be removed, taking care to clean the filter, float and reservoir thoroughly prior to reassembly. We recommend this is done in the Spring and the Autumn, using a chemically compatible anti-bacterial wash.
- Take great care to replace the float with the magnet facing upwards.*
- Additional inline filters are available if required.

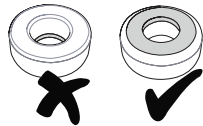

Trouble shooting

Fault: Pump runs all the time

1. Is float positioned with the magnet uppermost?
2. Is the reservoir lid (sensor) located firmly onto the reservoir, with the float located inside the reservoir, around the sensor column?
3. Is there sludge inside the reservoir, preventing float from resting on the bottom? (This may occur if pump has been in operation for some time without cleaning. Clean using an anti-bacterial wash.)

Please note:

- After installation and during operation, if you notice air in the pipe between the reservoir and the pump, you have a siphoning problem. (Follow advice in 'Preventing Siphoning' section).
- The pump will only switch off when the float is at the bottom of the reservoir.

Fault: Pump stops and starts and makes a loud noise.

1. The water is siphoning back through the pump. Follow advice in 'Preventing Siphoning' section.

Fault: Pump runs but does not pump any water.

1. Are there any air-leaks in the pipe running to the pump?
2. Check that reservoir and inlet tube are free of sludge and debris.

Fault: Pump isn't operating at all.

1. Is power reaching the pump? Is it correctly wired? Is the voltage correct?
2. Is pump very hot? A thermal cut-out may have been activated to protect pump. This will automatically reset once pump has cooled down.