

OUTDOOR UNIT

Installation and owner's manual
and information requirements

MAXI MVD V6R

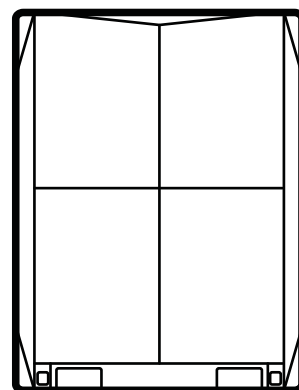

FR: "Manual d'utilisation et d'installation" voir www.mundoclima.com/fr
DE: "Benutzer- und Installationshandbuch" sehen www.mundoclima.com/de
PT: "Manual de instalação e do utilizador" ver www.mundoclima.com/pt



IMPORTANT

Thank you for selecting super quality air conditioner. To ensure satisfactory operation for many years to come, this manual should be read carefully before the installation and before using the air conditioner. After reading, store it a safe place. Please refer to the manual for questions on use or in the event that any irregularities occur. This Air Conditioner should be used for household or commercial use. This unit must be installed by a professional.

WARNING

The power supply must be SINGLE-PHASE (one phase (L) and one neutral (N)) with his grounded power (GND)) or THREE-PHASE (three phase (L1, L2, L3) and one neutral (N) with his grounded power (GND)) and his manual switch. Any breach of these specifications involve a breach of the warranty conditions provided by the manufacturer.

NOTICE

In line with the company's policy of continual product improvement, the aesthetic and dimensional characteristics, technical data and accessories of this appliance may be changed without notice.

ATTENTION

Read this manual carefully before installing or operating you new chiller unit. Make sure to save this manual for future reference.

CONTENTS

Installation manual	1
Owner's manual	49
Information requirements (Technical fiche LOT 21)	58

INSTALLATION MANUAL - CONTENTS

1 OVERVIEW	01
• 1.1 Meaning of Various Labels	01
• 1.2 What the Installation Operator Must Know	01
• 1.3 Important Information for User	03
2 ABOUT THE PACKING BOX	
• 2.1 Overview	03
• 2.2 Unbox the Outdoor Unit	04
• 2.3 Taking Out Accessories of Outdoor Unit	04
• 2.4 Pipe Fittings	04
• 2.5 Remove the Protect Board	04
3 ABOUT THE OUTDOOR UNIT COMBINATION	
• 3.1 Overview	05
• 3.2 Branch Joints	05
• 3.3 Recommended Outdoor Unit Combination	05
4 PREPARATIONS BEFORE INSTALLATION	
• 4.1 Overview	06
• 4.2 Choose and Prepare the Installation Site	06
• 4.3 Select and Prepare the Refrigerant Piping	07
• 4.4 Select and Prepare the Electrical Wiring	15
5 OUTDOOR UNIT INSTALLATION	
• 5.1 Overview	17
• 5.2 Open the Unit	17
• 5.3 Outdoor Unit Installation	18
• 5.4 Pipe Flushing	19
• 5.5 Pipe Welding	22
• 5.6 Gas Tightness Test	22
• 5.7 Vacuum Drying	23
• 5.8 Piping Insulation	24
• 5.9 Refrigerant Charging	24
• 5.10 Electrical Wiring	25
6 CONFIGURATION	
• 6.1 Overview	30
• 6.2 Dial Switch Settings	30
• 6.3 Digital Display and Button Settings	31
7 COMMISSIONING	
• 7.1 Overview	35
• 7.2 Things to Note During Test Run	35
• 7.3 Checklist before Test Run	35

• 7.4	About Test Run	36
• 7.5	Test Run Implementation	36
• 7.6	Rectifications after Test Run is Completed with Exceptions	36
• 7.7	Operating This Unit	36
8	MAINTENANCE AND REPAIR	
• 8.1	Overview	36
• 8.2	Safety Precautions for Maintenance	36
9	ERROR CODES	37
10	DISPOSAL	38
11	TECHNICAL DATA	
• 11.1	Dimensions	38
• 11.2	Maintenance Space: Outdoor Unit	39
• 11.3	Component Layout and Refrigerant Circuits	41
• 11.4	Fan Performance	43
• 11.5	Outdoor Unit Ducting	44
12	AUTOMATIC REFRIGERANT CHARGING GUIDELINE	
• 12.1	Preconditions	46
• 12.2	Procedure	46

1 OVERVIEW

1.1 Meaning of Various Labels

- The precautions and things to note in this document involve very important information. Please read them carefully.
- All the activities described in the installation manual must be performed by an authorized installation personnel.

WARNING

A situation that may lead to severe injury or death.

CAUTION

A situation that may lead to mild or moderate injury.

NOTE

A situation that may cause damage to the equipment or loss of property.

INFORMATION

Indicates a useful hint or additional information.

1.2 What the Installation Operator Must Know

1.2.1 Overview

If you are uncertain on how to install or run the unit, please contact the agent.

WARNING

- Make sure the installation, testing and materials used comply with the applicable law.
- Plastic bags should be disposed of properly. Avoid contact by children. Potential risk: Asphyxia.
- Do not touch the refrigerant piping, water piping or internal parts during operations, and when the operation has just been completed. This is because the temperature may be too high or too low. Let them recover to the normal temperature first. Wear protective gloves if you must come in contact with these.
- Do not touch any refrigerant that has accidentally leaked.

CAUTION

- Please wear the appropriate personal protective tools during installation, maintenance or repair of the system (protective gloves, safety glasses, etc.).
- Do not touch the air inlet or aluminium fin of the unit.

NOTE

- The figure shown in this manual is for reference only and may be slightly different from the actual product.
- Improper installation or connection of equipment and accessories may cause electric shocks, short circuits, leaks, fires, or other damage to the equipment. Use only accessories, equipment and spare parts made or approved by manufacturer.
- Take appropriate measures to prevent small animals from entering the unit. Contact between small animals and electrical components may cause system malfunction, leading to smoke or fire.
- Do not place any object or equipment on top of the unit.
- Do not sit, climb, or stand on the unit.
- Operation of this equipment in a residential environment could cause radio interference.

1.2.2 Installation site

- Provide sufficient space around the unit for maintenance and air circulation.
- Make sure the installation site can bear the weight of the unit and vibrations.
- Make sure the area is well ventilated.
- Make sure the unit is stable and level.

Do not install the unit in the following locations:

- An environment where there is a potential risk of explosions.
- Where there are equipment emitting electromagnetic waves. Electromagnetic waves may disrupt the control system, and cause the unit to malfunction.
- Where there are existing fire hazards like leakage of flammable gases, carbon fibres, and combustible dust (such as diluents or gasoline).
- Where corrosive gases (such as sulphurous gases) are produced. Corrosion of copper pipes or welded parts may lead to refrigerant leakage.

1.2.3 Refrigerant

WARNING

- During the test, do not exert a force greater than the maximum allowed pressure on the product (as shown on the nameplate).

WARNING

- Take appropriate precautions to prevent refrigerant leakage. If the refrigerant gas leaks, ventilate the area immediately. Possible risk: An excessively high concentration of refrigerant in an enclosed area can lead to anoxia (oxygen deficiency). The refrigerant gas may produce a toxic gas if it comes in contact with fire.
- Refrigerant must be recovered. Do not release it to the environment. Use the vacuum pump to draw the refrigerant out from the unit.

NOTE

- Make sure the refrigerant piping is installed in accordance with the applicable law. In Europe, EN378 is the applicable standard.
 - Make sure the piping and connections are not placed under pressure.
 - After all the piping connections have been completed, check to make sure there is no gas leak. Use nitrogen to conduct the leak check for gas.
 - Do not charge refrigerant before the wiring layout is completed.
 - Only charge the refrigerant after the leak tests and vacuum drying have been completed.
 - When charging the system with refrigerant, do not exceed the allowable charge to prevent liquid strike.
-
- Do not charge more than the specified amount of refrigerant. This is to prevent the compressor from malfunctioning.
 - The refrigerant type is clearly marked on the nameplate.
 - The unit is charged with refrigerant when it is shipped from the factory. But depending on the piping dimensions and length, the system require additional refrigerant.
 - Only use tools specific to the type of system refrigerant to make sure the system can withstand the pressure, and prevent foreign objects from entering the system.
 - Follow the steps below to charge the liquid refrigerant:
Open the refrigerating cylinder slowly.
Charge the liquid refrigerant. Charging with gas refrigerant may hamper normal operations.

CAUTION

Once refrigerant charging is completed or suspended, close the refrigerant tank valve immediately. The refrigerant may volatilize if the refrigerant tank valve is not closed in time.

1.2.4 Electricity

WARNING

- Make sure you switch off the power of the unit before you open the electric control box, and access any circuit wiring or components inside. At the same time, this prevents the unit from being accidentally powered up during installation or maintenance work.
- Once you open the cover of the electric control box, do not let any liquid spill into the box, and do not touch the components in the box with wet hands.
- Cut off power supply more than 10 minutes prior to access the electrical parts. Measure the voltage of the main circuit capacitor or electrical components terminals to make sure the voltage is less than 36 V before you touch any circuit component. Refer to the connections and wiring on the nameplate for the master circuit terminals and connections.
- The installation must be completed by professionals, and must comply with local laws and regulations.
- Make sure the unit is grounded, and the grounding must conform to the local law.
- Use only copper core wires for installation.
- Wiring must be carried out in accordance with what is stated in the nameplate.
- The unit does not include a safety switch device. Make sure a safety switch device that can completely disconnect all polarities is included in the installation, and that the safety device can be completely disconnected when there is excessive voltage (such as during a lightning strike).
- Make sure the wiring ends are not subjected to any external force. Do not pull or squeeze the cables and wires. At the same time, make sure the wiring ends are not in contact with the piping or sharp edges of the sheet metal.
- Do not connect the earth wire to public pipes, telephone earth wires, surge absorbers and other places that are not designed for grounding. A gentle reminder that improper grounding may cause electric shock.
- Use a dedicated power supply cord for the unit. Do not share the same power source with other equipment.
- A fuse or circuit breaker must be installed, and these must conform to the local law.
- Make sure an electric leakage protection device is installed to prevent electric shocks or fire. The model specifications and characteristics (anti high-frequency noise characteristics) of the electric leakage protection device are compatible with the unit to prevent frequent tripping.
- Make sure a lightning rod is installed if the unit is placed on the roof or other places that can be easily struck by lightning.
- Use H05RN-F, H07RN-F or above type power cord.

WARNING

- Make sure all terminals of the components are firmly connected before you close the cover of the electric control box. Before you power on and start the unit, check that the cover of the electric control box is tight and secured properly with screws. Do not let any liquid spill into the electric control box, and do not touch the components in the box with wet hands.
- The appliance shall be installed in accordance with national wiring regulations.
- If the supply cord is damaged, it must be replaced by the manufacturer or its service agent or a similarly qualified person in order to avoid a hazard.
- An all-pole disconnection switch having a contact separation of at least 3mm in all poles should be connected in fixed wiring.
- The dimensions of the space necessary for correct installation of the appliance including the minimum permissible distances to adjacent structures.
- The temperature of refrigerant circuit will be high, please keep the interconnection cable away from the copper tube.

NOTE

- Do not install the power cord near equipment that is susceptible to electromagnetic interference, such as TV, and radios to prevent interference.
- Use a dedicated power supply cord for the unit. Do not share the same power source with other equipment. A fuse or circuit breaker must be installed, and these must conform to the local law.

INFORMATION

The installation manual is only a general guide on the wiring and connections, and is not specifically designed to contain all information regarding this unit.

1.3 Important Information for User

- If you are uncertain on how to run the unit, please contact the installation personnel.
- This unit is not suitable for people who lack physical strength, cognitive sense or mental ability, or who lack experience and knowledge (including children). For their own safety, they should not use this unit unless they are supervised or guided by the respective personnel in charge of their safety. Children must be monitored to ensure that they do not play with this product.

WARNING

To prevent electric shock or fire:

- Do not wash the electric box of the unit.
- Do not operate the unit with wet hands.
- Do not place any items that contain water on the unit.

NOTE

- Do not place any object or equipment on top of the unit.
- Do not sit, climb, or stand on the unit.

2 ABOUT THE PACKING BOX



2.1 Overview

This chapter mainly introduces the subsequent operations after the outdoor unit has been delivered to site and unpacked.

This specifically includes the following information:

- Unbox and handling the outdoor unit.
- Take out the accessories of the outdoor unit.
- Dismantle the transport rack.

Remember the following:

- At the time of delivery, check the unit for any damage. Report any damage immediately to the carrier's claim agent.
- As far as possible, transport the packaged unit to its final installation site to prevent damage during the handling process.
- Take note of the following items when transporting the unit:
 -  Fragile. Handle with care.
 -  Keep the unit with its front facing upwards so as not to damage the
- Select the unit transportation path in advance.
- As shown in the following figure, it is better to use a crane and two long belts to lift the unit. Handle the unit carefully to protect it, and note the position of the centre of gravity of the unit.

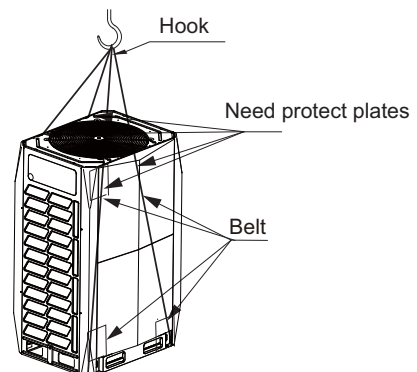

NOTE

- Use a leather belt that can adequately support the weight of the unit, and has a width ≤ 20 mm.
- Images are for reference only. Please refer to the actual product.

2.2 Unbox the Outdoor Unit

Take the unit out from the packing materials:

- Be careful not to damage the unit when you use a cutting tool to remove the wrapping film.
- Remove the four nuts on the wooden back stand.

WARNING

Plastic film should be disposed of properly. Avoid contact by children. Potential risk: Asphyxia.

2.3 Taking Out Accessories of Outdoor Unit

- The accessories for the unit are stored in two parts. Documents like the manual are located at the top of the unit. Accessories like the pipes are located inside the unit, on top of the compressor. The accessories in the unit are as follows:

Name	Qty.	Outline	Function
Installation manual and Owner's manual	1		—
Erp information	1		—
Tie wrap	2		—
Screw pack	1	—	Reserved for maintenance
90° socket elbow	1		To connect piping (For 10-18HP)
Sealing cover	8		To clean pipes
L-shaped pipe connection	3		To connect gas and liquid pipes
Build-out resistor	2		To improve communication stability
Wrench	1		To remove the side plate screws

2.4 Pipe Fittings

- The schematic after the L-shaped pipe (from accessories) is properly connected to the unit is shown below:

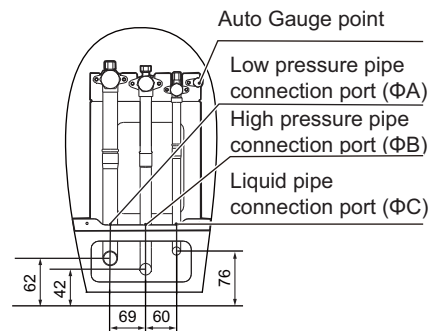
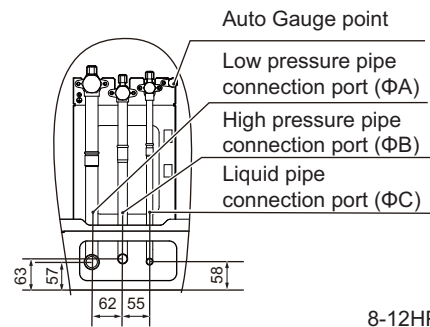

Unit: mm

HP SIZE	8	10	12	14	16	18
ΦA	19.1	22.2	28.6	28.6	28.6	28.6
ΦB	15.9	19.1	19.1	22.2	22.2	22.2
ΦC	9.52	9.52	12.7	12.7	12.7	15.9

2.5 Remove the Protect Board

For some models, there are protecting boards placed around the condenser. Please remove the protecting boards when installing the unit, otherwise the capacity of the outdoor unit will be affected.

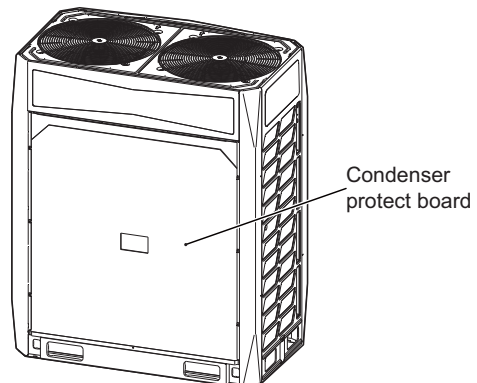

3 ABOUT THE OUTDOOR UNIT COMBINATION

3.1 Overview

This chapter contains the following information:

- List of branch joint fittings.
- Recommended combination for outdoor unit.

3.2 Branch Joints

Description	Model Name
Outdoor Unit Branch Joint Assembly	FQZHW-02SB1
	FQZHW-03SB1
Indoor Unit Branch Joint Assembly	FQZHN-01SB1
	FQZHN-02SB1
	FQZHN-03SB1
	FQZHN-04SB1
	FQZHN-05SB1
	FQZHN-01D
	FQZHN-02D

On the choice of branch joints, refer to section “4.3.3 Selecting piping diameters”.

3.3 Recommended Outdoor Unit Combination

HP \ HP	8	10	12	14	16	18	Max. Qty. of indoor units ¹
8	•						64
10		•					64
12			•				64
14				•			64
16					•		64
18						•	64
20		••					64
22		•	•				64
24		•		•			64
26			•	•			64
28			•		•		64
30			•			•	64
32					••		64
34					•	•	64
36						••	64
38			••	•			64
40			••		•		64
42			•	•	•		64
44			•		••		64
46				•	••		64
48					•••		64
50					••	•	64
52					•	••	64
54						•••	64

Note:

1.The maximum quantity of connected indoor units depend upon indoor unit type and total combination ratio.

CAUTION

- In the system where all indoor units are running at the same time, the total capacity of the indoor units should be less than or equal to the combined capacity of the outdoor unit to prevent overloading in bad working conditions or narrow operating space.
- If the system is applied in a cold region (ambient temperature is -10°C and below) or a very hot, heavy loading environment, the total capacity of the indoor units should be less than the combined capacity of the outdoor unit.

4 PREPARATIONS BEFORE INSTALLATION

4.1 Overview

This chapter mainly describes the precautions and things to note before the unit is installed at the site.

This mainly includes the following information:

- Choose and Prepare the Installation Site.
- Select and Prepare the Refrigerant Piping.
- Select and Prepare the Electrical Wiring.

4.2 Choose and Prepare the Installation Site

4.2.1 Site requirements for installation of outdoor unit

- Provide sufficient space around the unit for maintenance and air circulation.
- Make sure the installation site can bear the weight of the unit and vibrations.
- Make sure the area is well ventilated.
- Make sure the unit is stable and level.
- Choose a place where the rain can be avoided as much as possible.
- The unit should be installed in a location where the noise generated by the unit will not cause any inconveniences to any person.
- Choose a site that will comply with the applicable law.

Do not install the unit in the following locations:

- An environment where there is a potential risk of explosions.
- Where there are equipment emitting electromagnetic waves. Electromagnetic waves may disrupt the control system, and cause the unit to malfunction.
- Where there are existing fire hazards like leakage of flammable gases, carbon fibres, and combustible dust (such as diluents or gasoline).
- Where corrosive gases (such as sulphurous gases) are produced. Corrosion of copper pipes or welded parts may lead to refrigerant leakage.
- Where mineral oil mist, spray, or steam may exist in the atmosphere. Plastic parts may age, fall off or cause water leakage.
- Where there is a high salt content in the air such as places near the sea.

CAUTION

- Electric appliances that should not be used by the general public must be installed in the safety area to prevent others from getting close to these electric appliances.
- Both indoor and outdoor units are suitable for the installation of commercial and light industrial environment.
- An excessively high concentration of refrigerant in an enclosed area can lead to anoxia (oxygen deficiency).

NOTE

- This is a class A product. This product may cause radio interference in the home environment. The user may need to take the necessary measures if such a situation does arise.
- The unit described in this manual may cause electronic noise generated by radio frequency energy. The unit conforms to the design specifications and provides reasonable protection to prevent such interference. However, there is no guarantee that there will be no interference during a specific installation process.
- Therefore, it is suggested that you install the units and wires at an appropriate distance from devices like sound equipment and personal computers.

- Do take into considerations adverse environmental conditions such as strong winds, typhoons or earthquakes as an improper installation may cause the unit to overturn.
- Take precautions to make sure the water will not damage the installation space and environment in the event of a water leakage.
- If the unit is installed in a small room, refer to section 4.2.3 "Safety measures to prevent refrigerant leak" to make sure the refrigerant concentration does not exceed the permissible safety limit when there is a refrigerant leak.
- Make sure the air inlet of the unit is not directed at the main wind direction. Incoming wind will disrupt the operations of the unit. If necessary, use a deflector as an air baffle.
- Add water discharge piping on the base so that the condensed water will not damage the unit, and prevent the accumulation of water to form pits when the works are in progress.

4.2.2 Site requirements for installation of outdoor unit in cold regions

NOTE

Snow protection facilities must be installed in areas with snowfall. Refer to the following figure, (malfunctions are more common when there is insufficient snow protection facilities). In order to protect the unit from accumulated snow, increase the height of the rack, and install a snow shield at the air inlets and outlets.

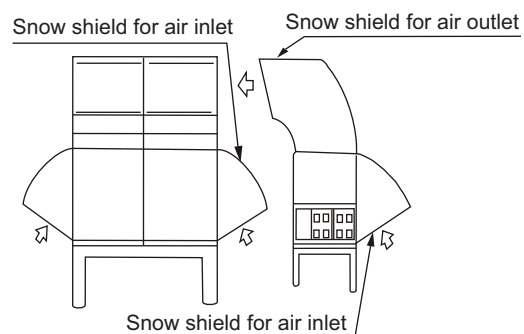

Fig. 4-1

NOTE

Do not obstruct the air flow of the unit when you install the snow shield.

4.2.3 Safety measures to prevent refrigerant leak

Safety measures to prevent refrigerant leak

The installation personnel must make sure the safety measures to prevent leaks comply with local regulations or standards. If the local regulations do not apply, the following criteria can be applied.

The system uses R410A as the refrigerant. R410A itself is a completely non-toxic, and non-combustible refrigerant. However, do ensure that the air conditioning unit is installed in a room with sufficient space. This is so that when there is a serious leak in the system, the maximum concentration of the refrigerant gas in the room will not exceed the stipulated concentration, and is consistent with the relevant local regulations and standards.

About the maximum concentration level

The calculation for the maximum concentration of the refrigerant is directly related to the occupied space that the refrigerant may leak to and the charging amount of the refrigerant.

The measurement unit for concentration is kg/m^3 (weight of gaseous refrigerant that has a volume of 1 m^3 in the occupied space).

The highest level of permissible concentration must comply with the relevant local regulations and standards.

Based on the applicable European standards, the maximum permissible concentration level of R410A in the space occupied by humans is limited to 0.44 kg/m^3 .

4.2.4 Frequency of Refrigerant Leak Checks

NOTE

- For equipment that contains fluorinated greenhouse gases in quantities of 5 tonnes of CO_2 equivalent or more, but of less than 50 tonnes of CO_2 equipment, at least every 12 months, or where a leakage detection system is installed, at least every 24 months.
- For equipment that contains fluorinated greenhouse gases in quantities of 50 tonnes of CO_2 equivalent or more, but of less than 500 tonnes of CO_2 equipment, at least every six months, or where a leakage detection system is installed, at least every 12 months.
- For equipment that contains fluorinated greenhouse gases in quantities of 500 tonnes of CO_2 equivalent or more, at least every three months, or where a leakage detection system is installed, at least every six months.
- Non-hermetically sealed equipment charged with fluorinated greenhouse gases shall only be sold to the end user where evidence is provided that the installation is to be carried out by an undertaking certified person.
- Only certificated person is allowed to do installation, operation and maintenance.

4.3 Select and Prepare the Refrigerant Piping

4.3.1 Refrigerant piping requirements

NOTE

The R410A refrigerant pipeline system must be kept strictly clean, dry and sealed.

- Cleaning and drying: prevent foreign objects (including mineral oil or water) from mixing into the system.
- Seal: R410A does not contain fluorine, does not destroy the ozone layer, and does not deplete the ozone layer that protect the earth from harmful ultraviolet radiation. But if it is released, R410A can also cause a slight greenhouse effect. Therefore, you must pay special attention when you check the sealing quality of the installation.
- The piping and other pressure vessels must comply with the applicable laws and suitable for use with the refrigerant. Use only phosphoric acid deoxidized seamless copper for the refrigerant piping.
- Foreign objects in the pipes (including lubricant used during pipe bending) must be $\leq 30 \text{ mg/10m}$.
- Calculate all piping lengths and distances.

4.3.2 Design considerations

NOTE

- If 12 ports or less are required, only one mode selection (MS) box is required. If 13 ports or more are required, multiple MS boxes are required. Choose appropriate MS box on the basis of actual conditions.
- The amount of brazing required should be kept to a minimum.
- As bends cause pressure loss on transportation of refrigerant, the fewer bends in the system, the better it is. Piping length needs to take the equivalent length of bends into account (the equivalent length of each branch joint is 0.5 m).
- On the two inside sides of the first branch joint, the system should, as far as possible, be equal in terms of number of units, total capacities and total piping lengths.
- Indoor units connected to the MS box sharing one port cannot operate in heating and cooling modes simultaneously. (i.e. they must function in either heating or cooling in tandem.)
- Indoor units with a capacity more than 16 kW should be connected to 2 ports merged in a multi MS box using branch joints. Merged ports must start on an odd number and with the next sequential even number (i.e. 1, 2 or 3, 4 and so on). And if a single MS box is used, the downstream indoor units can be up to a maximum capacity of 32 kW.

4.3.3 Selecting piping diameters

Fig. 4-1. Selecting piping diameters

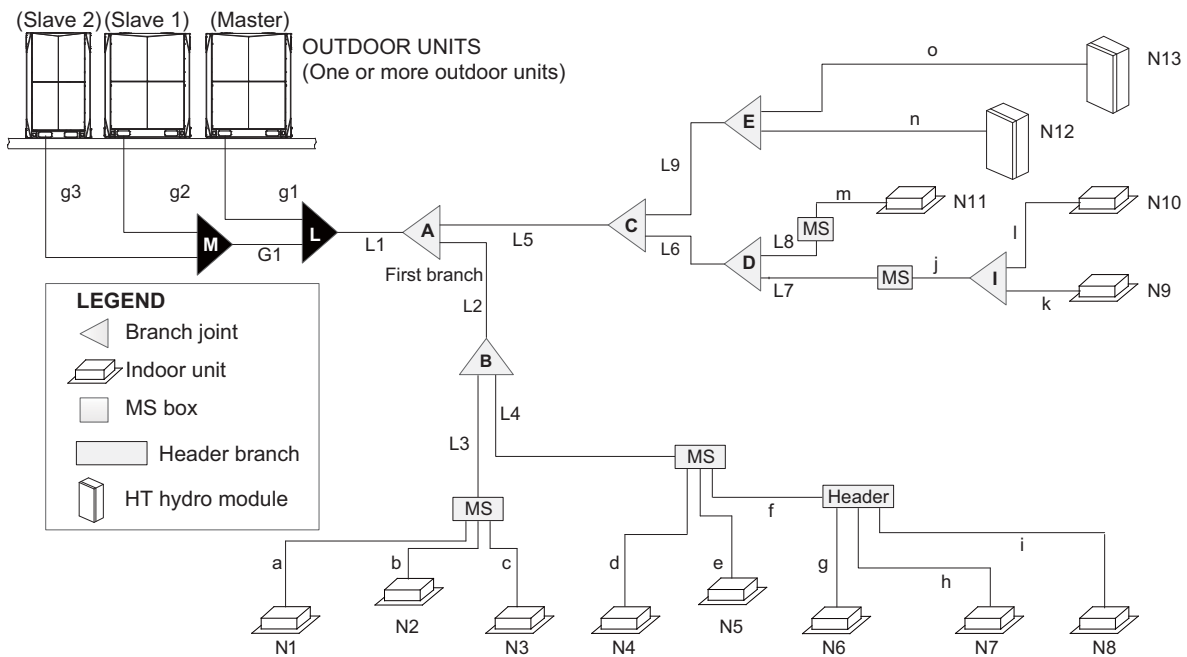

Table 4-1. Piping and Component Names

NAME	Designation
Outdoor unit connection pipe	g1, g2, g3, G1
Outdoor unit branch joint	L, M
Main pipe	L1
Indoor unit main pipe	L2 to L9
Branch joint between main pipe and MS box or HT hydro module	A to E
Branch joint between MS box and indoor unit	I
Indoor unit auxiliary pipe	a to o
VRF indoor unit	N1 to N11
High temperature hydro module (HT hydro module)	N12 , N13

Notes:

1. When multiple mode selection (MS) boxes are used in a single system, they should be installed in parallel, never in series.
2. Header branch (DXFQT4-01/DXFQT8-01) can only be installed downstream of MS box.
3. Branches and others header branches cannot be installed downstream of the initial head branch.

Table 4-2. Main pipe (L1) and first branch joint (A)

Outdoor Unit Capacity (HP)	Pipe Diameter (mm OD)			Branch joint kit
	Liquid pipe	Low Pressure Gas Pipe	High Pressure Gas Pipe	
8	Φ9.53	Φ19.1	Φ15.9	FQZHN-02SB1
10	Φ9.53	Φ22.2	Φ19.1	FQZHN-02SB1
12	Φ12.7	Φ28.6	Φ19.1	FQZHN-03SB1
14-16	Φ12.7	Φ28.6	Φ22.2	FQZHN-03SB1
18	Φ15.9	Φ28.6	Φ22.2	FQZHN-03SB1
20-22	Φ15.9	Φ28.6	Φ28.6	FQZHN-03SB1
24	Φ15.9	Φ34.9	Φ28.6	FQZHN-04SB1
26-34	Φ19.1	Φ34.9	Φ28.6	FQZHN-04SB1
36	Φ19.1	Φ41.3	Φ28.6	FQZHN-05SB1
38-54	Φ19.1	Φ41.3	Φ34.9	FQZHN-05SB1

Note:

When the equivalent piping length from outdoor units to the farthest indoor unit exceed 90 m, or the level difference is greater than 50 m (outdoor unit is above) or 40 m (outdoor unit is below), the liquid pipe of the main pipe (L1) should be increased as Table 4-12. More details are explained in the part of “4.3.4 Permitted piping lengths and level differences”.

Table 4-3. Outdoor unit connection pipes (g1 to g3, G1)

Pipes	Outdoor unit Capacity (HP)	Pipe Diameter (mm OD)		
		Liquid pipe	Low Pressure Gas Pipe	High Pressure Gas Pipe
g1 to g3	8	Φ9.53	Φ19.1	Φ15.9
	10	Φ9.53	Φ22.2	Φ19.1
	12	Φ12.7	Φ28.6	Φ19.1
	14-16	Φ12.7	Φ28.6	Φ22.2
	18	Φ15.9	Φ28.6	Φ22.2
G1	≤ 24	Φ15.9	Φ34.9	Φ28.6
	26-34	Φ19.1	Φ34.9	Φ28.6
	36	Φ19.1	Φ41.3	Φ28.6
	≥ 38	Φ19.1	Φ41.3	Φ34.9

Table 4-4. Outdoor unit branch joint kits (L, M)

Number of outdoor units	Branch joint kit
2	L: FQZHW-02SB1
3	L+M: FQZHW-03SB1

Table 4-5. Indoor unit main pipes (L2 to L8) and indoor unit branch joint kits

Total capacity of downstream indoor units (× 100W)	Pipe Diameter (mm OD)			Branch joint kit
	Liquid pipe	Low Pressure Gas Pipe	High Pressure Gas Pipe	
A < 168	Φ9.53	Φ15.9	Φ12.7	FQZHN-01SB1
168 ≤ A < 224	Φ9.53	Φ19.1	Φ15.9	FQZHN-02SB1
224 ≤ A < 330	Φ9.53	Φ22.2	Φ19.1	FQZHN-02SB1
330 ≤ A < 470	Φ12.7	Φ28.6	Φ19.1	FQZHN-03SB1
470 ≤ A < 710	Φ15.9	Φ28.6	Φ28.6	FQZHN-03SB1
710 ≤ A < 1040	Φ19.1	Φ34.9	Φ28.6	FQZHN-04SB1
1040 ≤ A	Φ19.1	Φ41.3	Φ28.6	FQZHN-05SB1

Notes:

1. Choose indoor main pipes from the above table in accordance with total downstream indoor capacity, which is the total capacity of all the indoor units, exclude HT hydro modules, connected downstream. Do not let the indoor unit main pipe exceed the main pipe chosen by outdoor unit capacity.

2. The downstream indoor units do not include HT hydro modules when calculate downstream indoor units capacity. If one or more HT hydro modules are connected to the system, the pipes (L9, n, o), only HT hydro modules connected downstream, are selected according to Table 4-6.

3. When the piping length between the farthest indoor unit and first branch joint (A) exceed 40 m, increase the diameter of the indoor main liquid pipes (the piping between the first branch joint and MS box) as Table 4-12. If the increased liquid pipe size is larger than the pipe size of the main liquid pipe (L1), also increase the size of the main liquid pipe. More details are explained in the part of “4.3.4 Permitted piping lengths and level differences”.

Table 4-6. HT hydro modules pipes (L9, n, o) and branch joint kits (only hydro modules connected downstream)

Total capacity of downstream hydro modules (× 100W)	Pipe Diameter (mm OD)		Branch joint kit
	Liquid pipe	Gas Pipe	
B < 168	Φ9.53	Φ12.7	FQZHN-01SB1
168 ≤ B < 224	Φ9.53	Φ15.9	FQZHN-02SB1
224 ≤ B < 330	Φ9.53	Φ19.1	FQZHN-02SB1
330 ≤ B < 470	Φ12.7	Φ19.1	FQZHN-03SB1
470 ≤ B < 710	Φ15.9	Φ28.6	FQZHN-03SB1
710 ≤ B < 1040	Φ19.1	Φ28.6	FQZHN-04SB1
1040 ≤ B	Φ19.1	Φ28.6	FQZHN-05SB1

Notes:

1. One or more HT hydro modules can be connected in the system with the first branch joint or its downstream branch joints, but never be connected under MS box or header branches, as Fig. 4-1.

2. Choose HT hydro module pipes from the above table in accordance with total downstream HT hydro modules capacity, which is the total capacity of all the HT hydro modules connected downstream.

Table 4-7. Indoor unit auxiliary pipes (a to m) and branch joint kits between MS box and downstream indoor units

Capacity of indoor units (× 100W)	Pipe Diameter (mm OD)		Branch joint kit
	Liquid pipe (mm)	Gas Pipe (mm)	
A < 56	Φ6.35	Φ12.7	FQZHN-01D
56 ≤ A ≤ 160	Φ9.53	Φ15.9	FQZHN-01D
160 < A ≤ 224	Φ9.53	Φ19.1	FQZHN-01D
224 < A	Φ9.53	Φ22.2	FQZHN-02D

Notes:

1. The branch joint kits are required only when two or more indoor units are connected to 1 port of MS box.

2. Indoor units with a capacity more than 16 kW should be connected to 2 ports merged in a multi MS box using branch joints (FQZHN-09A). Merged ports must start on an odd number and with the next sequential even number (i.e. 1, 2 or 3, 4 and so on). And if a single MS box is used, the downstream indoor units can be up to a maximum capacity of 32 kW.

The pipe thickness of the refrigerant piping shall comply with the applicable legislation.

The minimal pipe thickness for R410A piping must be in accordance with the Table 4-8.

Notes:

1. Material: Only seamless phosphorus-deoxidized copper piping that complies with all applicable legislation should be used.

2. Thicknesses: Temper grades and minimum thicknesses for different diameters of piping should comply with local regulations.

3. Design pressure of R410 refrigerant is 4.0 MPa (40 bar).

Table 4-8

Pipe Diameter (mm OD)	Minimum thickness (mm)	Temper grade
Φ6.35	0.80	M-type
Φ9.53	0.80	
Φ12.7	1.00	
Φ15.9	1.00	
Φ19.1	1.00	
Φ22.2	1.00	
Φ25.4	1.00	Y2-type
Φ28.6	1.00	
Φ31.8	1.25	
Φ34.9	1.25	
Φ38.1	1.50	
Φ41.3	1.50	
Φ44.5	1.50	
Φ50.8	1.80	
Φ54.0	1.80	

4.3.4 Permitted piping lengths and level differences

Table 4-9. Summary of permitted refrigerant piping lengths and level differences

Indoor Type	Maximum piping length			Maximum height difference		Total piping length
	Piping between farthest indoor unit and outdoor unit or the last multi-outdoor piping branch	Piping between farthest indoor unit and first indoor branch joint	Piping between outdoor unit and outdoor branch joint	Indoor unit to outdoor unit	Indoor unit to indoor unit	
	Actual(Equivalent)			Outdoor unit is above/ Outdoor unit is below		
VRF indoor units only	175 (200 m)	90 m	10 m	110 m / 110 m	30 m	1000 m
VRF indoor units and HT hydro modules	135 (160 m)	40 m	10 m	50 m / 40 m	30 m	600 m
VRF indoor units and AHUs	175 (200 m)	40 m	10 m	50 m / 40 m	30 m	1000 m

*The detailed instructions are explained below.

A. Connection with only VRF indoor units

Fig. 4-2. Permitted refrigerant piping lengths and level differences (A)

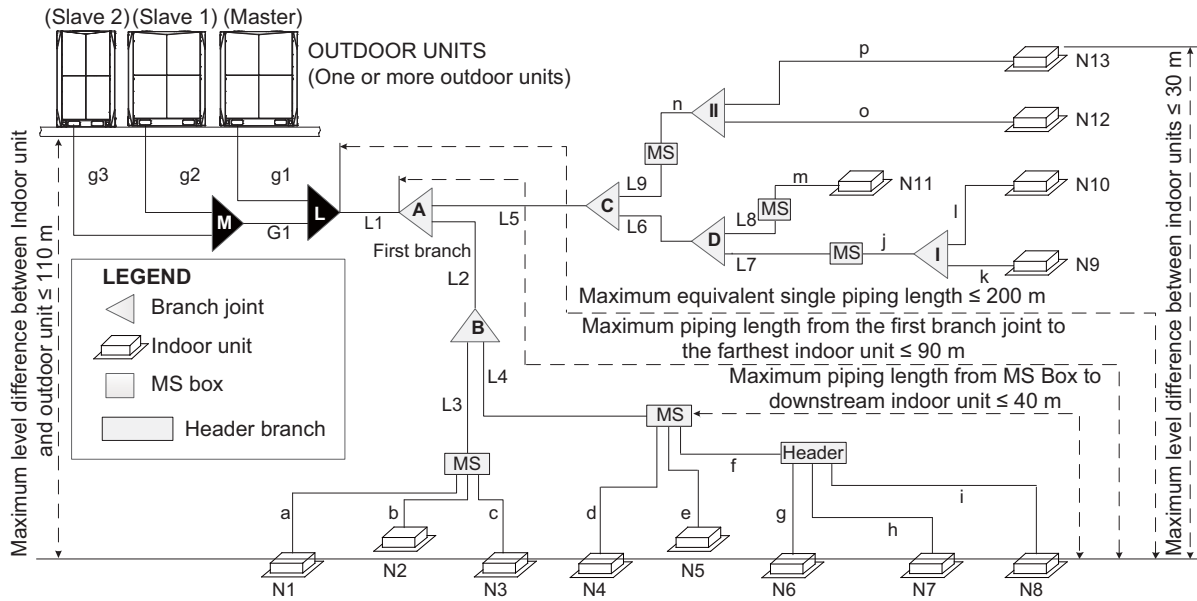

Table 4-10. Piping and Component Names

NAME	Designation
Outdoor unit connection pipe	g1, g2, g3, G1
Outdoor unit branch joint	L, M
Main pipe	L1
Indoor unit main pipe	L2 to L9
Branch joint between main pipe and MS box	A to D
Branch joint between MS box and indoor unit	I,II
Indoor unit auxiliary pipe	a to p
VRF indoor unit	N1 to N13

Table 4-11. Summary of permitted refrigerant piping lengths and level differences

		Permitted values	Piping in Fig. 4-2	
Piping lengths	Total piping length ¹	≤ 1000 m	$L1 + 2 \times \Sigma\{L2 \text{ to } L9\} + \Sigma\{a \text{ to } p\}$	
	Piping between farthest indoor unit and outdoor unit or the last multi-outdoor piping branch ²	Actual length	≤ 175 m	$L1 + L2 + L4 + f + i$
		Equivalent length	≤ 200 m	
	Piping between farthest indoor unit and first branch joint ³	≤ 40 m / 90 m	$L2 + L4 + f + i$	
	Piping between MS box to downstream indoor unit	≤ 40 m	$f + i$	
Piping between outdoor unit and outdoor branch joint	≤ 10 m	$g1 \leq 10 \text{ m}; g2+G1 \leq 10 \text{ m}; g3 + G1 \leq 10 \text{ m}$		
Level differences	Largest level difference between indoor unit and outdoor unit	Outdoor unit is above ⁴	≤ 110 m	
		Outdoor unit is below ⁵	≤ 110 m	
	Largest level difference between indoor units	≤ 30 m		

Notes:

1. The total length of piping in one refrigerant system should not exceed 1000m. When calculating the total length of piping, the actual length of the indoor main pipes (the piping between the first branch joint and MS box, L2 to L9) should be doubled.

2. The piping between the farthest indoor unit (N8) and outdoor unit or the last multi-outdoor piping branch joint (L) should not exceed 175 m (actual length) and 200 m (equivalent length). (The equivalent length of each branch joint is 0.5 m). When the equivalent piping length from outdoor units to the farthest indoor unit is ≥ 90 m, the liquid pipe of the main pipe (L1) should be increased as Table 4-12.

3. The piping between the farthest indoor unit (N8) and first branch joint (A) should not exceed 40 m in length ($L2 + L4 + f + i \leq 40$ m) unless the following conditions are met and the following measures are taken, in which case the permitted length is up to 90 m:

Conditions:

- a) The piping length from each indoor unit to the nearest MS box must be ≤ 40 m.
- b) The difference in length between the outdoor unit to the farthest indoor unit and the outdoor unit to the nearest indoor unit is ≤ 40 m. Example: The farthest indoor unit is N8, the nearest indoor unit is N3, $(L1 + L2 + L4 + f + i) - (L1 + L2 + L3 + c) \leq 40$ m.

Measures:

a) Increase the diameter of the indoor main liquid pipes (the piping between the first branch joint and MS box, L2 to L9) as Table 4-12. If the increased liquid pipe size is larger than the pipe size of the main liquid pipe (L1), also increase the size of the main liquid pipe.

4. If the outdoor unit is above and the level difference is greater than 50 m, the liquid pipe of the main pipe (L1) should be increased as Table 4-12. And it is recommended that an oil return bend with dimensions as specified in Fig.4-3 is set every 10 m in the gas pipe of the main pipe.

5. If the outdoor unit is below and the level difference is more than 40 m, the liquid pipe of the main pipe (L1) should be increased as Table 4-12.

6. The main liquid pipe (L1) and indoor main liquid pipes (L2 to L9) can only be sized once time if one or more of requirements are met in note 2 to note 5.

Table 4-12. Pipe size allowable increase diameters (mm)

9.53 to 12.7	12.7 to 15.9	15.9 to 19.1	19.1 to 22.2	22.2 to 25.4
--------------	--------------	--------------	--------------	--------------

Fig. 4-3. Oil return bend (unit: mm)

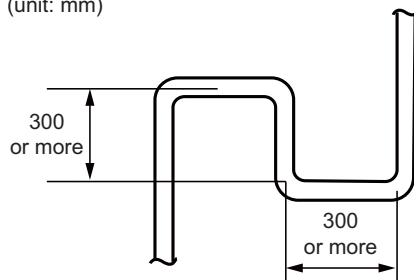

B. Connection with VRF indoor units and HT hydro modules

Fig. 4-4. Permitted refrigerant piping lengths and level differences (B)

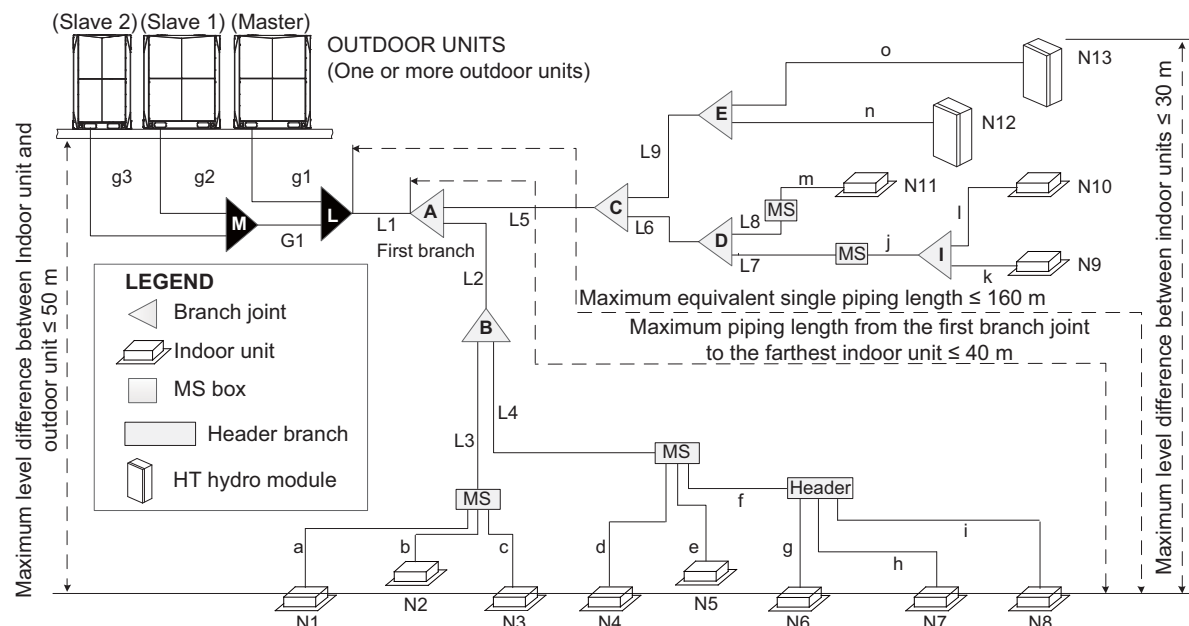

Table 4-13. Piping and Component Names

NAME	Designation
Outdoor unit connection pipe	g1, g2, g3, G1
Outdoor unit branch joint	L, M
Main pipe	L1
Indoor unit main pipe	L2 to L9
Branch joint between main pipe and MS box or HT hydro module	A to E
Branch joint between MS box and indoor unit	I
Indoor unit auxiliary pipe	a to o
VRF indoor unit	N1 to N11
HT hydro module	N12, N13

Table 4-14. Summary of permitted refrigerant piping lengths and level differences

		Permitted values	Piping in Fig. 4-4	
Piping lengths	Total piping length ¹	≤ 600 m	$L1 + 2 \times \Sigma\{L2 \text{ to } L9\} + \Sigma\{a \text{ to } o\}$	
	Piping between farthest VRF indoor unit or HT hydro module and outdoor unit or the last multi-outdoor piping branch ²	Actual length	≤ 135 m	$L1 + L2 + L4 + f + i$
		Equivalent length	≤ 160 m	
	Piping between farthest VRF indoor unit or HT hydro module and first branch joint	≤ 40 m	$L2 + L4 + f + i$	
	Piping between outdoor unit and outdoor branch joint	≤ 10 m	$g1 \leq 10 \text{ m}; g2 + G1 \leq 10 \text{ m}; g3 + G1 \leq 10 \text{ m}$	
Level differences	Largest level difference between VRF indoor unit or HT hydro module and outdoor unit	Outdoor unit is above	≤ 50 m	
		Outdoor unit is below	≤ 40 m	
	Largest level difference between VRF indoor units or HT hydro modules	≤ 30 m		

Notes:

1. The total length of piping in one refrigerant system should not exceed 600 m. When calculating the total length of piping, the actual length of the indoor main pipes (the piping between the first branch joint and MS box or last branch joint connected to HT hydro modules, L2 to L9) should be doubled.

2. The piping between the farthest VRF indoor unit (N8) or HT hydro module (N13) and outdoor unit or the last multi-outdoor piping branch joint (L) should not exceed 135 m (actual length) and 160 m (equivalent length). (The equivalent length of each branch joint is 0.5 m). When the equivalent piping length from outdoor units to the farthest VRF indoor unit or HT hydro module is ≥ 90 m, the liquid pipe of the main pipe (L1) should be increased as Table 4-12.

C. Connection with VRF indoor units and AHUs

Fig. 4-5. Permitted refrigerant piping lengths and level differences (C)

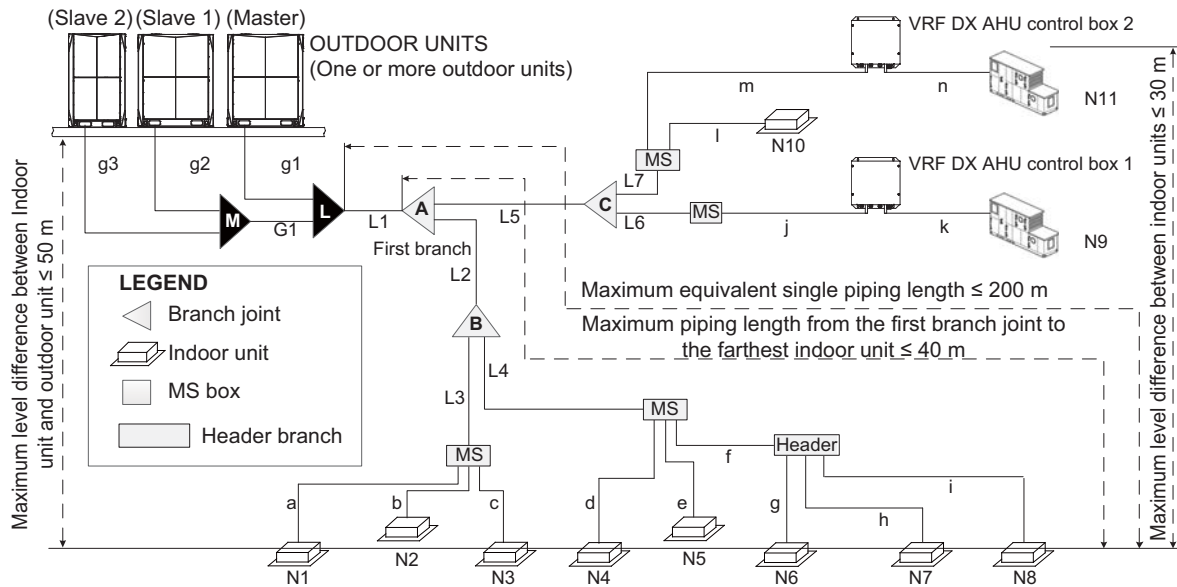

Table 4-15. Piping and Component Names

NAME	Designation
Outdoor unit connection pipe	g1, g2, g3, G1
Outdoor unit branch joint	L, M
Main pipe	L1
Indoor unit main pipe	L2 to L7
Branch joint between main pipe and MS box	A to C
Indoor unit auxiliary pipe	a to n
VRF indoor unit	N1 to N8, N10
AHU	N9, N11

Table 4-16. Summary of permitted refrigerant piping lengths and level differences

		Permitted values	Piping in Fig. 4-5	
Piping lengths	Total piping length ¹	≤ 1000 m	$L1 + 2 \times \sum\{L2 \text{ to } L7\} + \sum\{a \text{ to } n\}$	
	Piping between farthest VRF indoor unit or AHU and outdoor unit or the last multi-outdoor piping branch ²	Actual length	≤ 175 m	$L1 + L2 + L4 + f + i$
		Equivalent length	≤ 200 m	
	Piping between farthest VRF indoor unit or AHU and first branch joint ³	≤ 40 m	$L2 + L4 + f + i$	
	Piping between outdoor unit and outdoor branch joint	≤ 10 m	$g1 \leq 10 \text{ m}; g2 + G1 \leq 10 \text{ m}; g3 + G1 \leq 10 \text{ m}$	
Level differences	Largest level difference between VRF indoor unit or AHU and outdoor unit	Outdoor unit is above ⁴	≤ 50 m	
		Outdoor unit is below ⁵	≤ 40 m	
	Largest level difference between VRF indoor units or AHUs	≤ 30 m		

Notes:

1. The total length of piping in one refrigerant system should not exceed 1000 m. When calculating the total length of piping, the actual length of the indoor main pipes (the piping between the first indoor branch joint and MS box, L2 to L7) Σ should be doubled.

2. The piping between the farthest VRF indoor unit (N8) or AHU (N11) and outdoor unit or the last multi-outdoor piping branch joint (L) should not exceed 175 m (actual length) and 200 m (equivalent length). (The equivalent length of each branch joint is 0.5 m). When the equivalent piping length from outdoor units to the farthest VRF indoor unit or AHU is ≥ 90 m, the liquid pipe of the main pipe (L1) should be increased as Table 4-12.

4.3.5 Arrangement and layout of multiple outdoor units

- The piping between the outdoor units must be level or slightly upwards.
- The piping connecting the outdoor units should be horizontal and must not be higher than the refrigerant outlets. If necessary, to avoid obstacles the piping may be vertically offset below the outlets. When inserting a vertical offset to avoid an obstacle, the whole outdoor piping should be offset, rather than just the section adjacent to the obstacle.

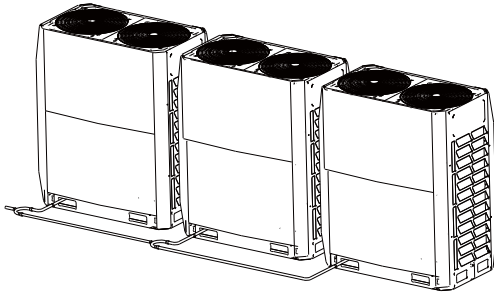

✓ Correct

Fig. 4-6

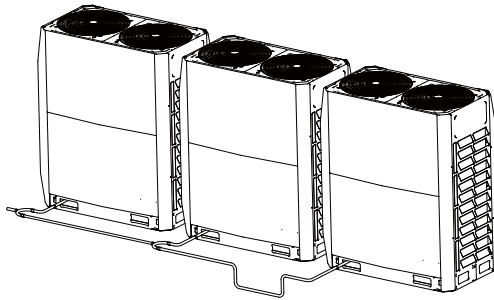

× Incorrect

Fig. 4-7

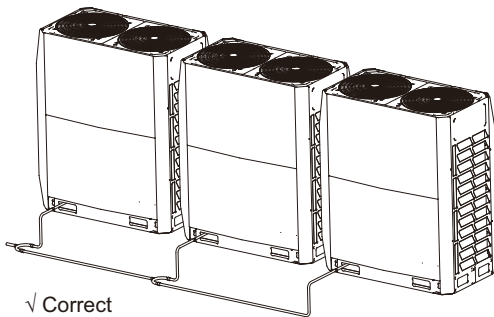

✓ Correct

Fig. 4-8

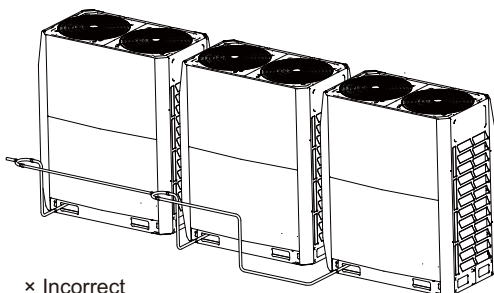

× Incorrect

Fig. 4-9

NOTE

In systems with multiple outdoor units, the units should be placed in order from largest capacity unit to smallest capacity unit. The largest capacity unit must be placed on the first branch, and be set as the master unit, while the others should be set as slave units. The capacity of outdoor units A, B and C must meet the following conditions: $A \geq B \geq C$.

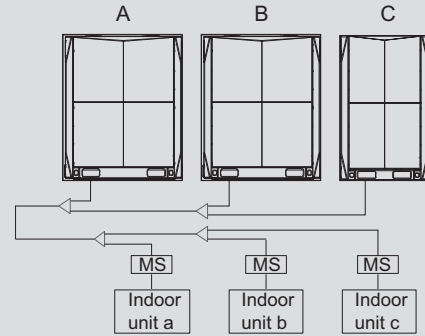

4.4 Select and Prepare the Electrical Wiring

4.4.1 Electrical compliance

This equipment conforms to:

EN/IEC 61000-3-12 specifications which states that the short circuit capacity (of the power supply), S_{sc} , is greater than or equal to the minimum S_{sc} value of the interface point between the user's power supply and the public system.

The installation personnel or users have the responsibility to consult the distribution network operators when necessary to ensure that the equipment only connects to a power supply with short circuit capacity, S_{sc} , greater than or equal to the minimum S_{sc} value.

Table 4-17

Capacity	Minimum S_{sc} value(kW)
8HP	4365
10HP	5336
12HP	5816
14HP	6789
16HP	8244
18HP	8729

Note:

The European / international technical standards specified a harmonic current limit for devices connected to a public low-voltage system where the input current of each phase > 16 A and ≤ 75 A.

4.4.2 Safety device requirements

1. Select the wire diameters(minimum value) individually for each unit based on the Table 4-18 and Table 4-19, where the rated current in table 4-18 means MCA in Table 4-19. In case the MCA exceeds 63 A, the wire diameters should be selected according to the national wiring regulation.
2. Maximum allowable voltage range variation between phases is 2%.
3. Select circuit breaker that having a contact separation in all poles not less than 3 mm providing full disconnection, where MFA is used to select the current circuit breakers and residual current operation breakers:

Table 4-18

Rated current of appliance (A)	Nominal cross-sectional area (mm ²)	
	Flexible cords	Cable for fixed wiring
≤ 3	0.5 and 0.75	1 to 2.5
> 3 and ≤ 6	0.75 and 1	1 to 2.5
> 6 and ≤ 10	1 and 1.5	1 to 2.5
> 10 and ≤ 16	1.5 and 2.5	1.5 to 4
> 16 and ≤ 25	2.5 and 4	2.5 to 6
> 25 and ≤ 32	4 and 6	4 to 10
> 32 and ≤ 50	6 and 10	6 to 16
> 50 and ≤ 63	10 and 16	10 to 25

Table 4-19

System	Outdoor Unit				Power Current			Compressor		Fan Motor	
	Voltage (V)	Frequency (Hz)	Min. (V)	Max. (V)	MCA (A)	TOCA (A)	MFA (A)	MSC (A)	RLA (A)	Power (kW)	FLA (A)
8HP	380-415	50	342	456	18.0	21.3	20.0	-	12.2	0.92	1.3
10HP	380-415	50	342	456	22.0	25.5	25.0	-	16.5	0.92	1.5
12HP	380-415	50	342	456	24.0	27.7	25.0	-	17.2	0.92	1.7
14HP	380-415	50	342	456	28.0	31.7	30.0	-	20.1	0.92×2	1.7
16HP	380-415	50	342	456	34.0	37.9	35.0	-	24.5	0.92×2	1.9
18HP	380-415	50	342	456	36.0	40.2	40.0	-	29.7	0.92×2	2.2

i INFORMATION

Phase and frequency of power supply system: 3N~50 Hz, Voltage: 380-415 V

Abbreviations:

MCA: Minimum Circuit Amps; TOCA: Total Over-current Amps; MFA: Maximum Fuse Amps; MSC: Maximum Starting Current (A); RLA: Rated Load Amps; FLA: Fan Load Amps

Notes:

1. Units are suitable for use on electrical systems where voltage supplied to unit terminals is not below or above listed range limits. Maximum allowable voltage variation between phases is 2%.
2. Select wire size based on the value of MCA.
3. TOCA indicates the total overcurrent amps value of each OC set.
4. MFA is used to select overcurrent circuit breakers and residual-current circuit breakers.
5. MSC indicates the maximum current on compressor start-up in amps.
6. RLA is based on the following conditions: indoor temperature 27°C DB, 19°C WB; outdoor temperature 35°C DB.

5 OUTDOOR UNIT INSTALLATION

5.1 Overview

This chapter includes the following information:

- Open the unit
- Outdoor unit installation
- Welding refrigerant piping
- Refrigerant piping check
- Refrigerant charging
- Power on the unit

5.2 Open the Unit

5.2.1 Open the outdoor unit

To enter the unit, you need to open the front panel, as shown below:

- For 8-18HP, first dismantle the front left and right pillars. Remove the screws, rotate and shift upwards by about 2 mm to remove left and right pillars.
- Dismantle upper panel: Each upper panel has 4 screws (8-18HP). After dismantling, lift it up by about 3 mm to take it out.
- Dismantle lower panel: Each lower panel has 4 screws (8-18HP). After dismantling, lift it up by about 3 mm to take it out.

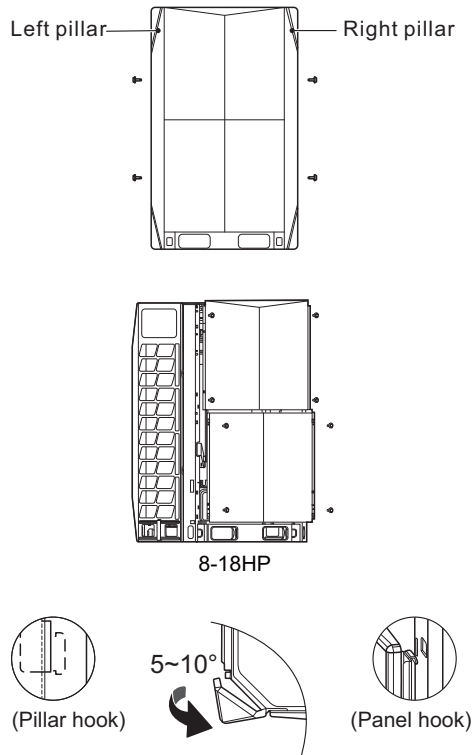

Fig. 5-1

5.2.2 Open the electric control box of outdoor unit

Once the front panel is opened, you can access the electric control box. Refer to section 5.2.2 on how to open the electric component box of the outdoor unit.

- Remove the cover of electric control box: (1) Loosen the two screws (by turning counter-clockwise for 1 to 3 turns) from the cover of the electric control box; (2) lift the cover upwards for 7 to 8 mm, and then turn it outwards for 10 to 20 mm; (3) slide down the cover to remove it.
- Open and rotate the middle partition plate: (1) Loosen the two screws (by turning counter-clockwise for 1 to 3 turns) from the middle partition plate; (2) lift the partition plate upwards for 4 to 6 mm, and then turn it outwards to open the partition plate; (3) slide the hinge (which can slide up and down along a sliding slot) at the bottom of the partition plate to the uppermost position to rotate the partition plate completely.

NOTE

Do not open the cover of electric control box until the preparing of wiring is OK.

The middle partition plate is used for maintaining. Do not open it when installation.

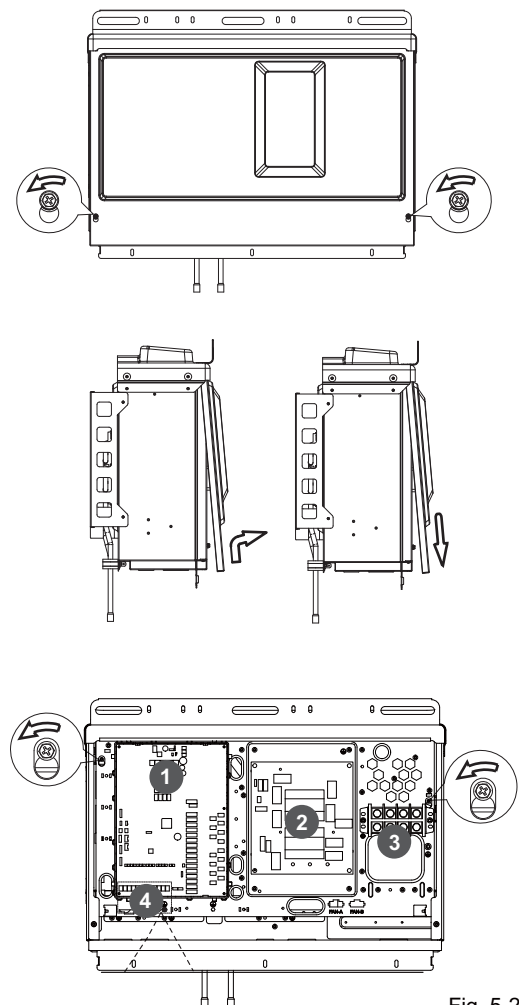
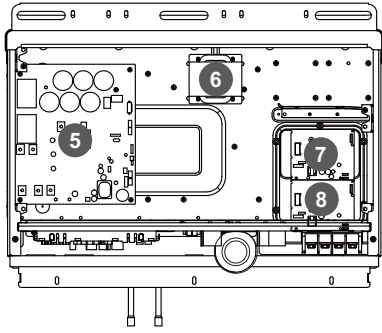

Fig. 5-2



The heat radiator piping of the refrigerant is connected to the system.

Fig. 5-3

- (1) Main board
- (2) AC filter board
- (3) Terminal block
- (4) Communication terminal block
- (5) Compressor drive board
- (6) Reatance
- (7) DC fan drive board
- (8) DC fan drive board (Only for 14-18HP)

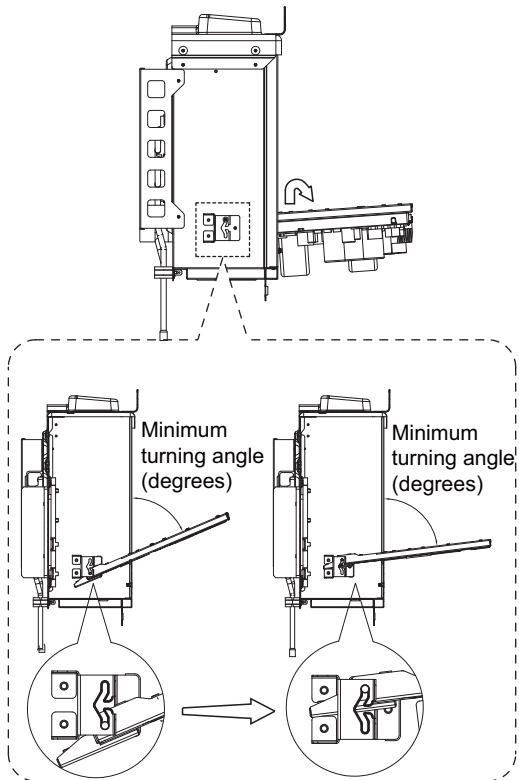

Fig. 5-4

CAUTION

- Make sure the power supply is off before you carry out any electric control installation and maintenance work.
- To remove the entire electric control box, first discharge the refrigerant from the system, disconnect the pipe connecting the refrigerant radiator at the bottom of the electric control box. At the same time, remove all wiring connecting the electric control box and the internal components of the air conditioner.
- The images shown here are for illustrative purposes only and may differ from the actual product due to reasons like model and product upgrade. Please refer to the actual product.

5.3 Outdoor Unit Installation

5.3.1 Prepare structure for installation

Make sure the base where the unit is installed is strong enough to prevent vibrations and noise.

- When there is a need to increase the installation height of the unit, it is recommended that you use the installation structure shown in the following figure. Use a rack to support the four corners of the unit where necessary.
- The unit must be installed on a solid longitudinal base (steel beam frame or concrete). Make sure the base below the unit is larger than the area shaded in grey.

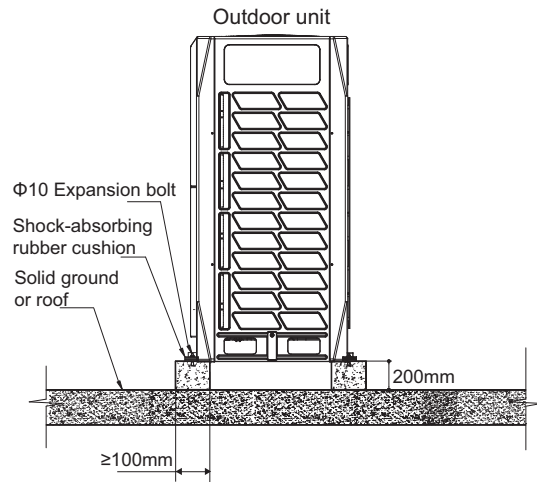

Fig. 5-5

Expansion bolt positioning (Unit: mm)

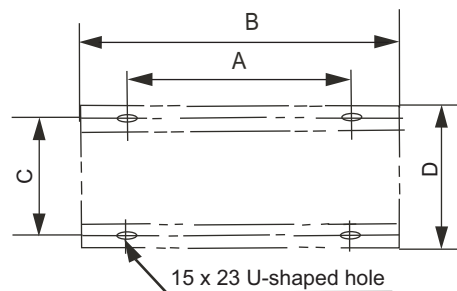
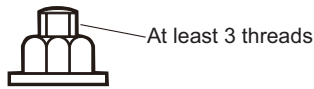

Fig. 5-6

- Use four ground bolts, M12, to secure the unit in place. Best is to screw in the ground bolt until it is embedded in the base surface by at least 3 threads.



NOTE

- The base of the outdoor unit must use the solid concrete surface as the cement base or the steel beam frame base.
- The base must be completely level to ensure that every point of contact is even.
- During installation, make sure the base supports the vertical folds of the front and back under plates of the chassis directly as the vertical folds of the front and back under plates are unit where the actual support for the unit load is.
- No gravel layer is required when the base is built on the roof surface, but the sand and cement on the concrete surface must be level, and the base should be chamfered along the edge. A water drainage ditch should be set around the base to drain the water around the equipment. Potential risk: slip.
- Check the load-bearing capacity of the roof to make sure it can support the load.
- When you choose to install the piping from the bottom, the base height should be above 200 mm.

Table 5-1 Unit: mm

SIZE \ HP	8,10,12	14,16,18
A	740	1090
B	990	1340
C	723	723
D	790	790

5.4 Pipe Welding

5.4.1 Things to note when connecting the refrigerant piping

CAUTION

- During the test, do not exert a force greater than the maximum allowed pressure on the product (as shown on the nameplate).
- Take appropriate precautions to prevent refrigerant leakage. Ventilate the area immediately if the refrigerant leaks. Possible risk (An excessively high concentration of refrigerant in an enclosed area can lead to anoxia (oxygen deficiency); the refrigerant gas may produce a toxic gas if it comes in contact with fire.)
- Refrigerant must be recovered. Do not release it to the environment. Use professional fluorine extraction equipment to extract the refrigerant from the unit.

NOTE

- Make sure the refrigerant piping is installed in accordance with the applicable law.
- Make sure the piping and connections are not placed under pressure.
- Before brazing, the refrigerant piping should be flushed with nitrogen to remove dust, moisture and other particles.
- After all the piping connections have been completed, check to make sure there is no gas leak. Use nitrogen to conduct the leak check for gas.

5.4.2 Connect refrigerant piping

Before the refrigerant piping is connected, make sure the indoor units, MS boxes and outdoor units are installed properly. Connecting refrigerant piping include:

- Connect refrigerant piping to outdoor unit.
- Connect refrigerant piping to MS box (refer to the installation manual of MS box).
- Connect refrigerant piping to indoor unit (refer to the installation manual of the indoor unit).
- Connecting VRF piping assembly.
- Assembly for connecting refrigerant piping branch joint.

Bear in mind the following guidelines:

- Braze.
- Stop valve is used correctly.

5.4.3 Outdoor refrigerant connecting pipe position

The outdoor refrigerant connecting pipe position is shown in the following figure.

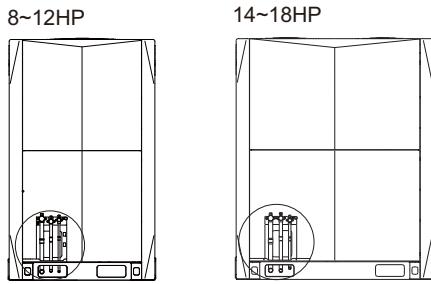

Fig. 5-7

5.4.4 Connecting refrigerant piping to outdoor unit

NOTE

- Note the precautions when connecting the field piping for the refrigerant. Add brazing material.
- Use the attached piping fittings when working on the pipeline engineering on site.
- After installation, make sure the piping does not come in contact with each other, or the chassis.

The fittings provided as accessories can be used to complete the connection from the stop valve to the field piping.

5.4.5 Connecting VRF piping assembly

CAUTION

- The wrong installation will cause the unit to malfunction.

The branch joints should be as level as possible, and the angular error does not exceed 10°.

U type branch joint

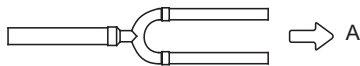

A-direction view

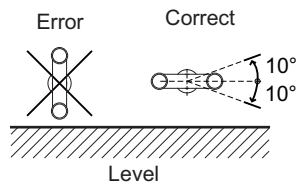

Fig. 5-8

When there are multiple outdoor units, the branch joints must not be higher than the refrigerant piping as shown below:

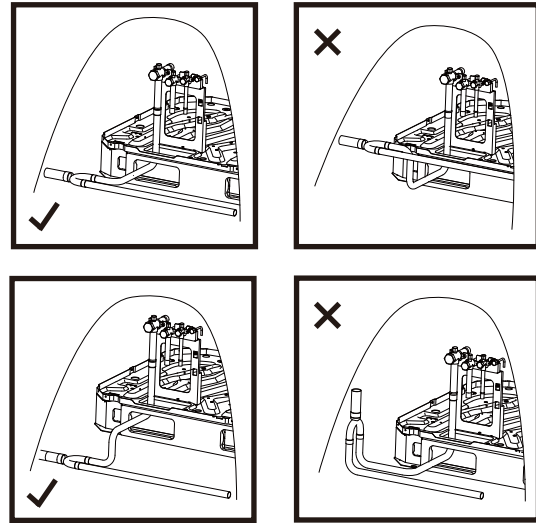

Fig. 5-9

5.4.6 Brazing

- During brazing, use nitrogen as protection to prevent the formation of a large amount of oxide film in the pipes. This oxide film will have adverse effects on the valves and compressors in the cooling system, and may hamper normal operations.
- Use the reducing valve to set the nitrogen pressure to 0.02~0.03 Mpa (a pressure that can be felt by the skin).

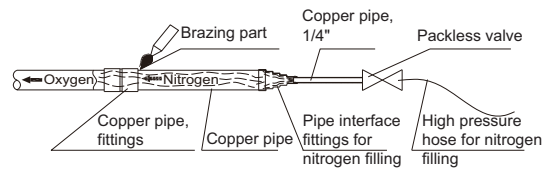

Fig. 5-10

- Do not use antioxidants when brazing the pipe joints.
- Use copper-phosphorus alloys (BCuP) when brazing copper and copper, and no flux is required. When brazing copper and other alloy, flux is required. Flux produces an extremely harmful effect on the refrigerant piping system. For example, using a chlorine-based flux is used may corrode the pipes, and when the flux contains fluorine, it will degrade the frozen oil.

5.4.7 Connect stop valves

The stop valve

- The following figure shows the names of all parts required for the installation of the stop valves.
- Stop valves are closed when unit is shipped from the factory. Do not open any stop valves until it is ready to start the system with all of the pre-commissioning checks have been completed.

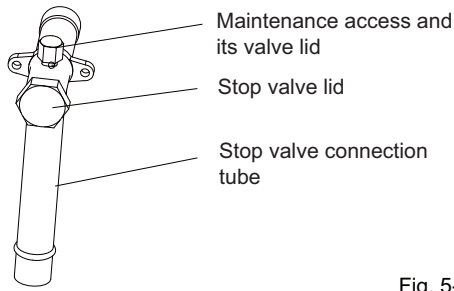

Fig. 5-11

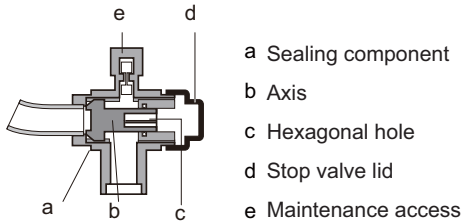

Fig. 5-12

Using of stop valve

1. Remove the stop valve lid.
2. Insert the hex wrench into the stop valve, and rotate the stop valve counter-clockwise.
3. Stop turning when the stop valve cannot be rotated further.

Result: Valve is now open.

The fastening torque of the stop valve is shown in table 5-2. Insufficient torque may cause the refrigerant to leak.

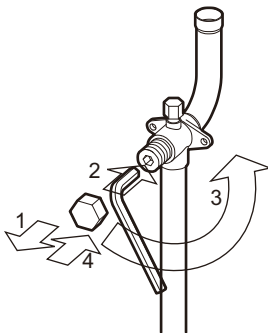

Fig. 5-13

Close stop valve

1. Remove the stop valve lid.
2. Insert the hex wrench into the stop valve, and rotate the stop valve clockwise.
3. Stop turning when the stop valve cannot be rotated further.

Result: Valve is now closed.

Direction to close:

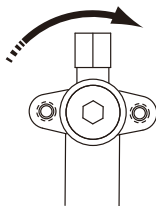

Fig. 5-14

Fastening torque

Table 5-2

Stop valve size (mm)	Tightening torque / N.m (turn clockwise to close)	
	Axis	
	Valve body	
Φ12.7	9~30	
Φ15.9	12~30	
Φ19.1	16~30	
Φ25.4	24~30	
Φ28.6	25~35	
Φ31.8		
Φ35.0		

5.4.8 Connecting refrigerant piping to MS boxes

- MS boxes include solenoid valves which control refrigerant flow through the individual indoor units so that unit operation (heating or cooling) matches the comfort requirements set by the occupant.
- Field piping connections for the outdoor unit gas and liquid pipes are provided on the right and left side of the MS box. Only one side can be used. Piping through the MS box to another MS box is not allowed. Use the proper branch joint kit when multiple mode selection boxes are connected.
- Refrigerant piping connections to outdoor unit(s) and indoor units are made with field braze connections.

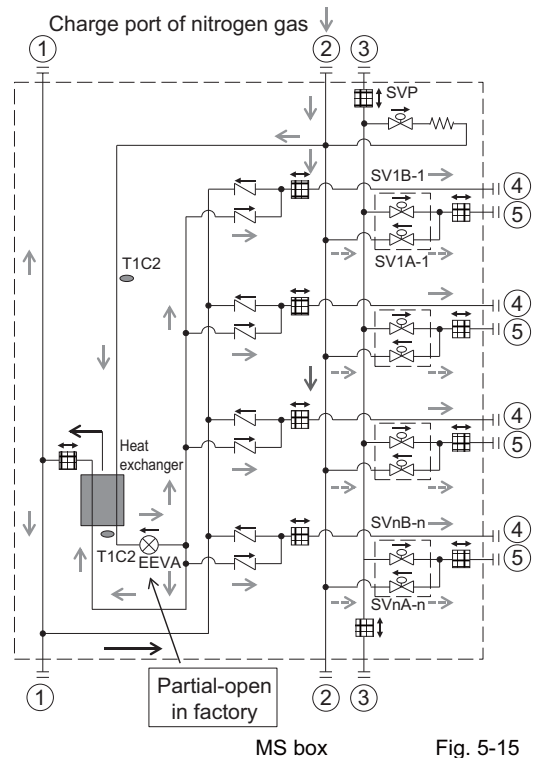

Fig. 5-15

- Normal charge (nitrogen pressure ≤ 20 kPa)
- Strong charge (nitrogen pressure > 20 kPa)

- ① Liquid pipe
- ② Low pressure gas pipe
- ③ High pressure gas pipe
- ④ Indoor liquid pipe
- ⑤ Indoor gas pipe

⚠ CAUTION

The refrigerant piping must be flushed before connecting to MS boxes to prevent impurities from blocking the MS boxes.

Nitrogen gas braze protection on MS box

Always flow/purge nitrogen to avoid oxidation while brazing. It is very important to charge nitrogen properly during brazing.

a) Normal charge from port ② while brazing port ④ and strong charge (> 20 kPa) from port ② while brazing port ⑤ as Fig.5-15.

b) Normal charge (≤ 20 kPa) from port ② while brazing port ① and normal charge from corresponding outdoor unit stop valve while brazing port ② and port ③ as Fig.5-15.

*Solenoid valve can be opened while downstream gas pressure is 20 kPa above that of upstream.

5.5 Pipe Flushing

The refrigerant piping should be flushed using nitrogen to remove dust, other particles and moisture, which could cause compressor malfunction if not flushed out before the system runs.

1. First, the refrigerant piping should be flushed with nitrogen before brazing.
2. And Pipe flushing should be performed before connecting refrigerant piping to MS boxes and indoor units to prevent impurities from blocking the MS boxes and indoor units.
 - a) Flush the refrigerant piping with nitrogen before brazing.
 - b) Braze the refrigerant piping and branch joints between outdoor unit(s) and MS box (piping (a) in Fig. 5-16), but not connect piping (a) to MS box.
 - c) Flush piping (a) with nitrogen, and then connect piping (a) to MS box according to the description of 5.4.8.
 - d) Braze the refrigerant piping and branch joints between MS and indoor units (piping (b) in Figure 5.16), but not connect piping (b) to MS box.
 - e) Flush piping (b) with nitrogen, and then connect piping (b) to MS box according to the description of 5.4.8.
 - f) Flush all refrigerant piping from outdoor unit stop valves to ensure no impurities remain.
 - g) Finally, connect piping (b) to indoor units.

⚠ CAUTION

Only use nitrogen for flushing. Using carbon dioxide risks leaving condensation in the piping. Oxygen, air, refrigerant, flammable gases and toxic gases must not be used for flushing. Use of such gases may result in fire or explosion.

Flushing piping (a)

For outdoor unit, the liquid pipe, low pressure and high pressure gas pipe can be flushed simultaneously; alternatively, one pipe can be flushed first and then Steps 1 to 5 repeated, for another pipe. The flushing procedure is as follows:

1. Attach a pressure reducing valve to a nitrogen cylinder.
2. Connect the pressure reducing valve outlet to the corresponding stop valve of the outdoor unit.
3. Start to open the nitrogen cylinder valve and gradually increase the pressure to 0.5 MPa.
4. Allow time for nitrogen to flow as far as the outlet of piping (a).
5. Flush piping (a):
 - a) Using suitable material, such as a bag or cloth, press firmly against the outlet of piping (a).
 - b) When the pressure becomes too high to block with your hand, suddenly remove your hand allowing gas to rush out.
 - c) Repeatedly flush in this manner until no further dirt or moisture is emitted from the piping. Use a clean cloth to check for dirt or moisture being emitted. Seal the outlet once it has been flushed.
6. Once flushing is completed, seal all main pipes to prevent dust and moisture from entering.

Flushing piping (b)

The procedure for flushing piping (b) is similar to that for piping (a). Flush nitrogen from one end of piping (b). And repeat steps until all indoor pipes are flushed.

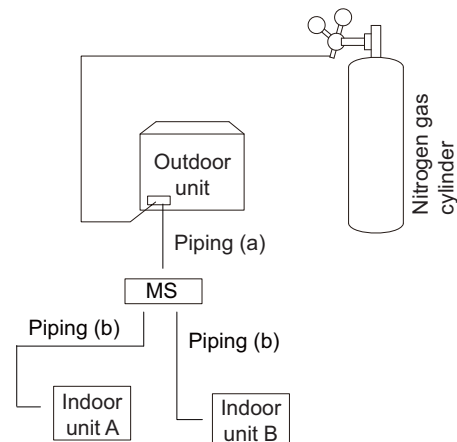

Fig. 5-16

5.6 Gas Tightness Test

To prevent faults caused by refrigerant leakage, a gas tightness test should be performed before system commissioning.

⚠ CAUTION

- Only dry nitrogen should be used for gas tightness testing. Oxygen, air, flammable gases and toxic gases must not be used for gas tightness testing. Use of such gases may result in fire or explosion.
- Make sure that all the outdoor unit stop valves are firmly closed.

The gas tightness test procedure is as follows:

1. Once the piping system is completed and the indoor, MS box and outdoor units have been connected, vacuum the piping to -0.1 MPa.
2. Charge the indoor piping with nitrogen at 0.3 MPa through the needle valves on the liquid, high pressure and low pressure gas stop valves and leave for at least 3 minutes (do not open the liquid or gas stop valves). Observe the pressure gauge to check for large leakages. If there is a large leakage, the pressure gauge will drop quickly.
3. If there are no large leakages, charge the piping with nitrogen at 1.5 MPa and leave for at least 3 minutes. Observe the pressure gauge to check for small leakages. If there is a small leakage, the pressure gauge will drop distinctly.
4. If there are no small leakages, charge the piping with nitrogen at 4.0 MPa and leave for at least 24 hours to check for micro leakages. Micro leakages are difficult to detect. To check for micro leakages, allow for any change in ambient temperature over the test period by adjusting the reference pressure by 0.01 MPa per 1°C of temperature difference. Adjusted reference pressure = pressure at pressurization + (temperature at observation - temperature at pressurization) x 0.01 MPa. Compare the observed pressure with the adjusted reference pressure. If they are the same, the piping has passed the gas tightness test. If the observed pressure is lower than the adjusted reference pressure, the piping has a micro leakage.
5. If the leakage is detected, refer to following part "Leak detection". Once the leak has been found and fixed, the gas tightness test should be repeated.
6. If not continuing straight to vacuum drying once the gas tightness test is complete, reduce the system pressure to 0.5 - 0.8 MPa and leave the system pressurized until ready to carry out the vacuum drying procedure.

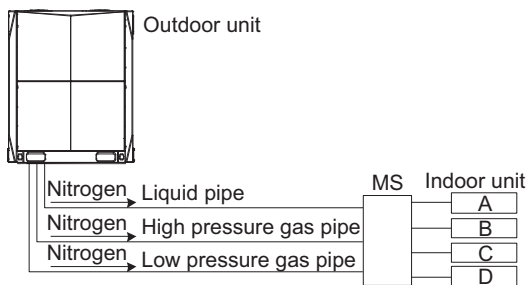

Fig. 5-17

Leak detection

The general methods for identifying the source of a leak are as follows:

1. Audio detection: relatively large leaks are audible.
2. Touch detection: place your hand at joints to feel for escaping gas.
3. Soapy water detection: small leaks can be detected by the formation of bubbles when soapy water is applied to a joint.

5.7 Vacuum Drying

Vacuum drying should be performed in order to remove moisture and non-condensable gases from the system. Removing moisture prevents ice formation and oxidization of copper piping or other internal components. The presence of ice particles in the system would cause abnormal operation, whilst particles of oxidized copper can cause compressor damage. The presence of non-condensable gases in the system would lead to pressure fluctuations and poor heat exchange performance.

Vacuum drying also provides additional leak detection (in addition to the gastightness test).

CAUTION

- Before performing vacuum drying, make sure that all the outdoor unit stop valves are firmly closed.
- Once the vacuum drying is complete and the vacuum pump is stopped, the low pressure in the piping could suck vacuum pump lubricant into the air conditioning system. The same could happen if the vacuum pump stops unexpectedly during the vacuum drying procedure. Mixing of pump lubricant with compressor oil could cause compressor malfunction. Therefore a check valve should be used to prevent vacuum pump lubricant seeping into the piping system.

During vacuum drying, a vacuum pump is used to lower the pressure in the piping to the extent that any moisture present evaporates. At 5 mm Hg (755 mm Hg below typical atmospheric pressure) the boiling point of water is 0°C. Therefore a vacuum pump capable of maintaining a pressure of -756 mm Hg or lower should be used. Using a vacuum pump with a discharge in excess of 4 L/s and a precision level of 0.02 mm Hg is recommended. The vacuum drying procedure is as follows:

1. Connect the vacuum pump through a manifold with a pressure gauge to the service port of all stop valves.
2. Start the vacuum pump and then open the manifold valves to start vacuuming the system.
3. After 30 minutes, close the manifold valves.
4. After a further 5 to 10 minutes check the pressure gauge. If the gauge has returned to zero, check for leakages in the refrigerant piping.
5. Re-open the manifold valves and continue vacuum drying for at least 2 hours and until a pressure difference of 0.1 MPa or more has been achieved. Once the pressure difference of at least 0.1 MPa has been achieved, continue vacuum drying for 2 hours. Close the manifold valves and then stop the vacuum pump. After 1 hour, check the pressure gauge. If the pressure in the piping has not increased, the procedure is finished. If the pressure has increased, check for leakages.
6. After vacuum drying, keep the manifold connected to the master unit stop valves, in preparation for refrigerant charging.

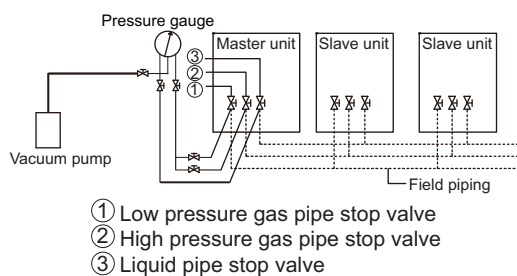

Fig. 5-18

5.8 Piping Insulation

After the leak test and the vacuum drying are completed, the pipe must be insulated. Considerations:

- Make sure the refrigerant piping and branch joints are completely insulated.
- Make sure the liquid and gas pipes (for all units) are insulated.
- Use heat-resistant polyethylene foam for the liquid pipes (able to withstand temperature of 70°C), and polyethylene foam for the gas pipes (able to withstand temperature of 120°C).
- Reinforce the insulation layer of the refrigerant piping based on the installation environment.

Condensed water may form on the surface of the insulation layer.

Piping size	Humidity<80%RH Thickness	Humidity≥80%RH Thickness
Φ6.4~38.1 mm	≥ 15 mm	≥ 20 mm
Φ41.3~54.0 mm	≥ 20 mm	≥ 25 mm

5.9 Refrigerant Charging

⚠ WARNING

- Use only R410A as the refrigerant. Other substances may cause explosions and accidents.
- R410A contains fluorinated greenhouse gases, and the GWP value is 2088. Do not discharge the gas into the atmosphere.
- When charging the refrigerant, make sure you wear protective gloves and safety glasses. Be careful when you open the refrigerant piping.

💡 NOTE

- If the power supply of some units is off, the charging program cannot be completed normally.
- If this is a multi-unit outdoor system, the power supply for all outdoor units should be turned on.
- Make sure the power supply is turned on 12 hours before operations so that the crankcase heater is properly energized. This is also to protect the compressor.

💡 NOTE

- Make sure all connected indoor units have been identified.
- Charge the refrigerant only after the system has not failed the gas tightness tests and vacuum drying.
- Volume of refrigerant charged must not exceed the designed amount.

Calculating additional refrigerant charge

The additional refrigerant charge required depends on outdoor unit model, MS box model and the lengths and diameters of the outdoor and indoor liquid pipes. Table 5-3 to 5-5 show the additional refrigerant charge required under different conditions.

Table 5-3. Additional refrigerant charge amount R1 (according to outdoor unit model)

Outdoor unit model	Additional refrigerant charge per model (kg)
8HP	2
10HP	2
12HP	2.6
14HP	4.9
16HP	5.5
18HP	5.7

Table 5-4. Additional refrigerant charge amount R2 (according to MS box model)

MS box model	Additional refrigerant charge per model (kg)
MS01	0.1
MS04	0.5
MS06	0.5
MS08	1
MS10	1
MS12	1

Table 5-5. Additional refrigerant charge amount R3 (according to liquid pipe lengths and diameters)

Liquid piping Diameter (mm OD)	Additional refrigerant charge per meter of equivalent length of liquid piping (kg)
Φ6.35	0.022
Φ9.53	0.057
Φ12.7	0.110
Φ15.9	0.170
Φ19.1	0.260
Φ22.2	0.360
Φ25.4	0.520
Φ28.6	0.680

Note: The additional refrigerant charge amount (R3) is obtained by summing the additional charge requirements for each of the outdoor and indoor liquid pipes, as in the following formula, where L1 to L8 represent the equivalent lengths of the pipes of different diameters. Assume 0.5 m for the equivalent pipe length of each branch joint.

Additional refrigerant charge amount R3 (kg) = L1 (Φ 6.35) × 0.022 + L2 (Φ9.53) × 0.057 + L3 (Φ12.7) × 0.110 + L4 (Φ15.9) × 0.170 + L5 (Φ19.1) × 0.260 + L6 (Φ22.2) × 0.360 + L7 (Φ25.4) × 0.520 + L8 (Φ28.6) × 0.680

Total additional refrigerant charge amount (R) is equal to the sum of R1, R2 and R3, calculate the amount of refrigerant to be charged according to the formula below:

$$R \text{ (kg)} = R1 + R2 + R3.$$

The procedure for adding refrigerant is as follows:

1. Calculate additional refrigerant charge R (kg).
2. Place a tank of R410A refrigerant on a weighing scale. Turn the tank upside down to ensure refrigerant is charged in a liquid state. (R410A is a blend of two different chemicals compounds. Charging gaseous R410A into the system could mean that the refrigerant charged is not the correct composition).
3. After vacuum drying, the manifold should still be connected to the master unit stop valves.
4. Connect the manifold from the pressure gauge to the R410A refrigerant tank.
5. Open the valve where the hose (hose a) meet the pressure gauge, and open the refrigerant tank slightly to let the refrigerant eliminate the air.

Caution: open the tank slowly to avoid freezing your hand.

6. Set the weighing scale to zero.
7. Open the manifold valves to begin charging refrigerant.
8. When the amount charged reaches R (kg), close the manifold valves. If the amount charged has not reached R (kg) but no additional refrigerant can be charged, close the manifold valves, run the outdoor units in cooling mode, and then open the manifold valve A, C and D. Continue charging from the service port of low pressure stop valve until the full R (kg) of refrigerant has been charged, then close the manifold valve A, C and D. Note: Before running the system, be sure to complete all the pre-commissioning checks and be sure to open all stop valves as running the system with the stop valves closed would damage the compressor.

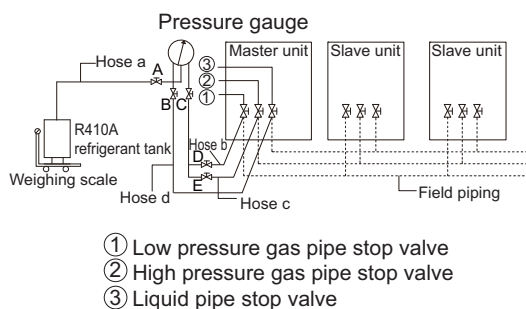

Fig. 5-19

5.10 Electrical Wiring

5.10.1 Electrical wiring precautions

⚠ WARNING

- Take note of the risk of electric shocks during installation.
- All the electric wires and components must be installed by an installation personnel with the proper electrician certification, and the installation process must comply with the applicable regulations.
- Use only wires with copper cores for the connections.
- A main switch or safety device that can disconnect all polarities must be installed, and the switching device can be completely disconnected when the corresponding excessive voltage situation arises.
- Wiring must be carried out in strict accordance with what is stated in the product nameplate.
- Do not squeeze or pull the unit connection, and make sure the wiring is not in contact with the sharp edges of the sheet metal.
- Make sure the grounding connection is safe and reliable. Do not connect the earth wire to public pipes, telephone earth wires, surge absorbers and other places that are not designed for grounding. Improper grounding may cause electric shock.

Make sure the fuses and circuit breakers installed meet the corresponding specifications.

- Make sure an electric leakage protection device is installed to prevent electric shocks or fires.
- The model specifications and characteristics (anti high-frequency noise characteristics) of the electric leakage protection device are compatible with the unit to prevent frequent tripping.
- Before power on, make sure the connections between the power cord and terminals of the components are secure, and the metallic cover of the electric control box is closed tightly.
- If HT hydro module connects to the system, please refer to the installation manual of the HT hydro module.

💡 NOTE

- If the power supply lacks N phase or there is an error in the N phase, the device will malfunction.
- The N phase must connect to mark N of the terminal block, or the device will malfunction.

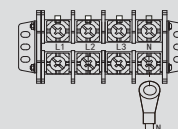

- Do not share the same power supply line with other devices.

NOTE

- Some power equipment may have an inverted phase or intermittent phase (such as a generator). For this type of power sources, a reverse-phase protection circuit should be installed locally in the unit, as operating in the inverted phase may damage the unit.
- The power cord may produce electromagnetic interference so you should maintain a certain distance from equipment that may be susceptible to such interference.
- Indoor units or MS box in the same system must be powered by the same power supply, in order not to damage the system.
- Power supply for the indoor or MS box should separate from outdoor units.
- For systems with multiple units, make sure a different address is set for each outdoor unit.

5.10.2 Wiring layout (overview)

Wiring layout comprises of the power cords and communication wiring between the indoor, MS box and outdoor units. These include the earth lines, and the shielded layer of the earth lines of the indoor units in the P, Q, E communication line. See below for an example of a wiring layout.

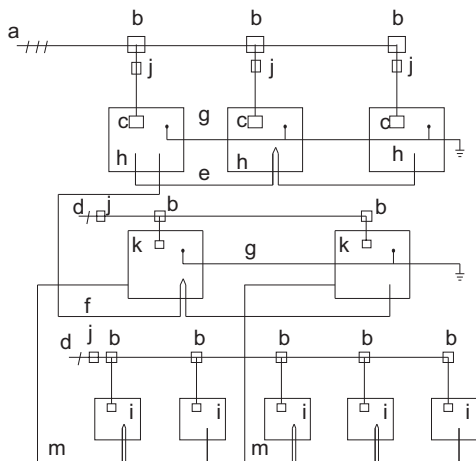

a	Three-phase power supply (with earth lines and leakage protection)
b	Power distribution box
c	Power supply terminal of outdoor unit
d	Single phase power supply (with earth lines and leakage protection)
e	H1, H2 and E communication wire (with shielded layer) between outdoor unit and outdoor unit
f	P, Q and E communication wire (with shielded layer) between outdoor unit and MS box
g	Earth line
h	Outdoor unit
i	Indoor unit
j	Main switch (with leakage protection)
k	MS box
m	P, Q and E communication wire (with shielded layer) between MS box and Indoor unit

Fig. 5-20

5.10.3 About wiring layout

NOTE

- Power cords and communication wiring must be laid out separately, they cannot be placed in the same conduit. Use a power supply conduit to isolate if the current of the power supply is less than 10 A. If the current is greater than 10 A but less than 50 A, the spacing must exceed 500 mm at all times. otherwise, it may lead to electromagnetic interference.
- Arrange the refrigerant piping, power cords and communication wiring in parallel, but do not tie the communication lines together with the refrigerant piping or power cords.
- Power cords and communication wiring should not come in contact with the internal piping so as to prevent the high temperature piping from damaging the wires.
- Once the wiring layout is completed, close the lid tightly to prevent the wiring and terminals from being exposed when the lid is loose.

5.10.4 Communication wiring layout

5.10.4.1 Wiring mode

Communication wiring of outdoor unit: The H1, H2, E communication lines of the outdoor unit should be connected in a chain starting from the master unit to the last slave unit, as shown below.

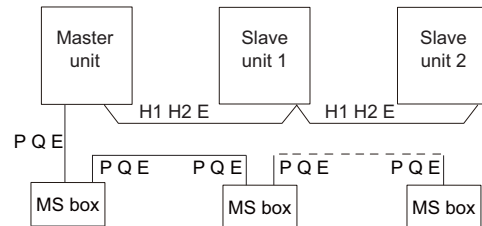
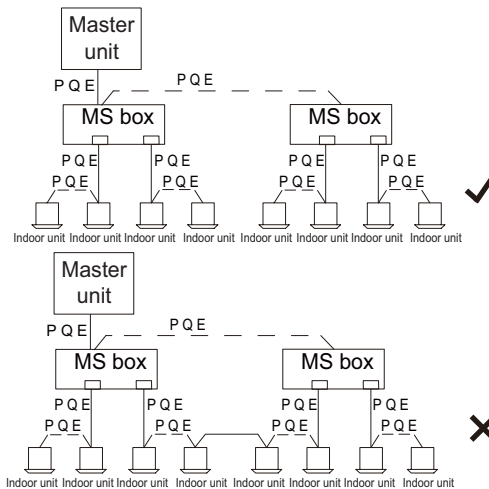
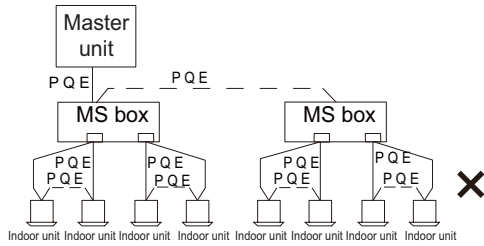

Fig. 5-21

Communication wiring of indoor unit: The P, Q, E communication line should be connected in a chain starting from the outdoor unit to each MS box, and then from the MS box to each indoor unit. In the last indoor unit, connect a resistor of 120 ohms between the P and Q terminals. The correct and wrong connection methods are demonstrated below:



The indoor units under the different MS box, the communication wiring can not connect.



The last indoor unit from the same port on the MS box, the communication wiring should not route back to the port as this will form a closed loop.

Fig. 5-22

NOTE

Three-core shielded cable should be used for communication wiring. The cross-sectional area of each core of the communication wiring is not less than 0.75 mm², and the length must not exceed 1200 m. A communication error may result when the communication wiring exceeds these limitations.

5.10.4.2 Place and fix communication wiring

Place the communication wiring along the front of the unit, and secured with a corresponding tie.

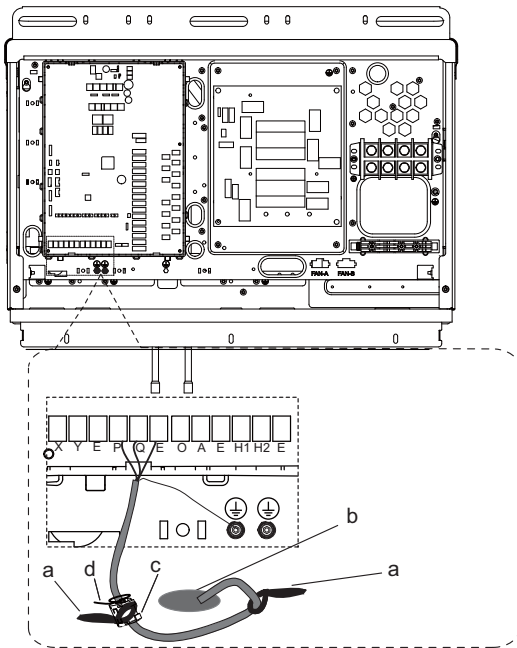

a	Wire clamp
b	Via for communication wiring
c	Magnet ring
d	Tie wrap

Fig. 5-23

NOTE

The communication wiring P, Q, E must through the magnetic ring from the main board to the MS box or HT hydro module.

5.10.4.3 Communications wiring

The communication wiring of the MS box must be connected to the P, Q, E terminal on the PCB of the communication terminals block of the outdoor unit. The communication wiring between outdoor units must be connected to the H1, H2, E terminals on the PCB of the communication terminals block of the outdoor unit.

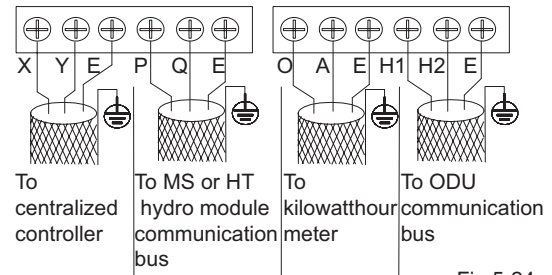

Fig.5-24

communication connections

Terminals	Connection
O A E	Connect to kilowattour meter
X Y E	Connect to centralized controller
P Q E	Connect to MS box or HT hydro module communication bus
H1 H2 E	Connect to ODU communication bus

Installation of a single outdoor unit is as below:

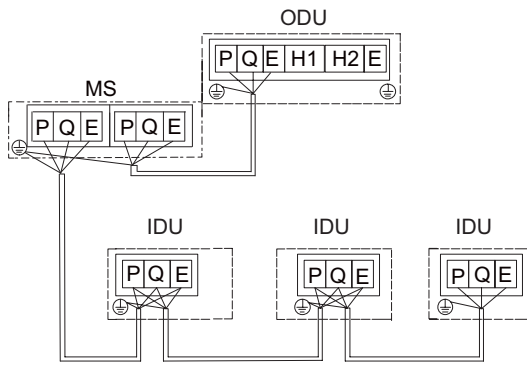

Fig.5-25

Installation of multiple outdoor units is as below:

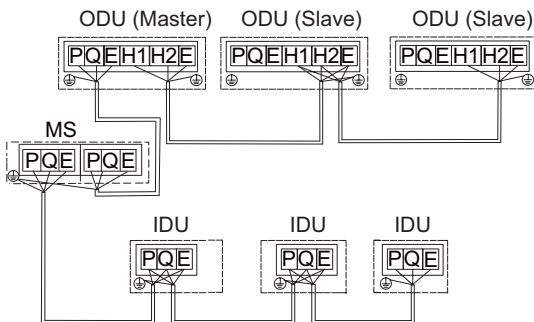

Fig.5-26

The recommend tightening torque for the communication terminals block is as follows:

Screw Specification	Tightening torque, N.m
M3	0.5~0.6

NOTE

- When there are multiple outdoor units in the same system, the H1, H2, E of one unit must be connected to the H1, H2, E of another unit. Connection to the P, Q, E will cause a system malfunction.
- In systems with multiple outdoor units, each outdoor unit should be set address. Only the master outdoor unit can communicate with MS box or HT hydro module.
- Before the performance test, set the number of the indoor unit, the address of the outdoor unit. After the test run is completed, you cannot randomly change these DIP switches.

5.10.5 Connecting the power cord

5.10.5.1 Fixing the power cord

8-12HP

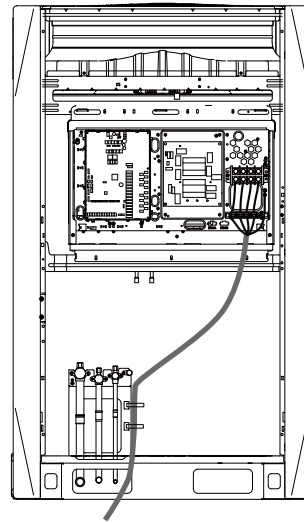

14-18HP

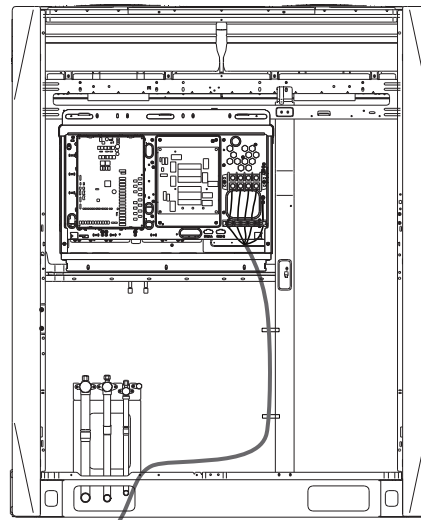

Fig.5-27

5.10.5.2 Power cord connections

NOTE

- Do not connect the power supply to the communication terminal block. Otherwise, the whole system may fail.
- You must first connect the earth line (note that you should use only the yellow-green wire to connect to earth, and you must turn off the power supply when you are connecting the earth line) before you connect the power cord. Before you install the screws, you must first comb through the path along the wiring to prevent any part of the wiring from becoming exceptionally loose or tight because the lengths of the power cord and earth line are not consistent.
- The wire diameter must comply with the specified specification, and make sure the terminal is screwed tight. At the same time, do not subject the terminal to any external force.
- Do tighten the terminal with an appropriate screwdriver. Screwdrivers that are too small may damage the terminal head, and cannot tighten it.
- Excessive tightening of the terminal may cause the screw thread to deform and slip, making it impossible to connect the components securely.
- Only use a ring terminal to connect the power cord. Non-standard cable connection will lead to poor contact which may in turn cause exceptional heating and burning. The figure below demonstrates both the correct and wrong connections.

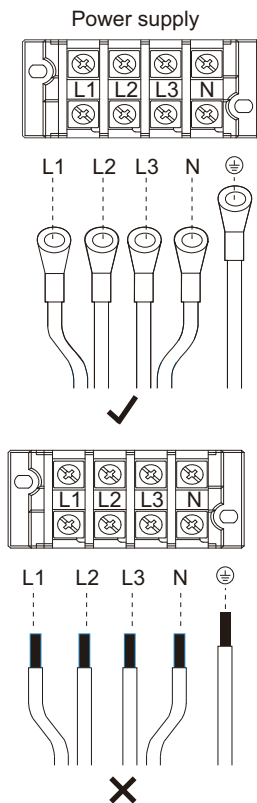

Fig.5-28

The size of the screws (power supply terminal specifications) and recommended torque are as follows:

Screw specification	Tightening torque, N.m
M8	5.5~7.0

Steps to fix the power cord:

1. First, peel part of the skin of the outermost insulating layer (refer to the third point below for the specific length). Connect the power cable to the terminal, and install the screws.
2. Position the wire clip. Be careful not to reverse the first step, or it will be difficult to install the screws.
3. The wire clip has been fixed at a position on the sheet metal near the terminal of the electric control box. Put the power cable in the corresponding slot between the base and upper cover. Select the appropriate slot based on the specific diameter of the cable. When the cross-sectional area of the power cable is less than 10 mm², place the entire power cord inside the slot. At this time, make sure both the length of the peel and the length of the terminal are less than 70 mm, as shown below.

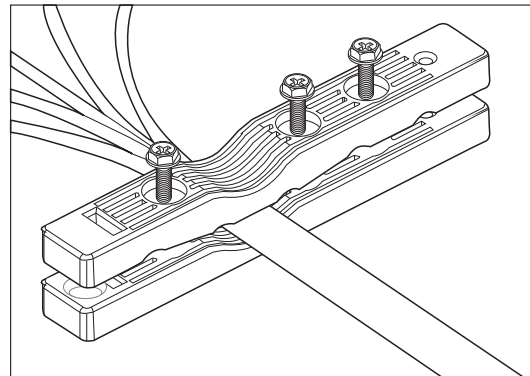

Fig.5-29

When the cross sectional area of the power cable exceeds 10 mm², place the power cables separately in the slot. When the skin is peeled, make sure the sum of the length of the peel and the length of the terminal is between 100 mm and 200 mm, as shown below.

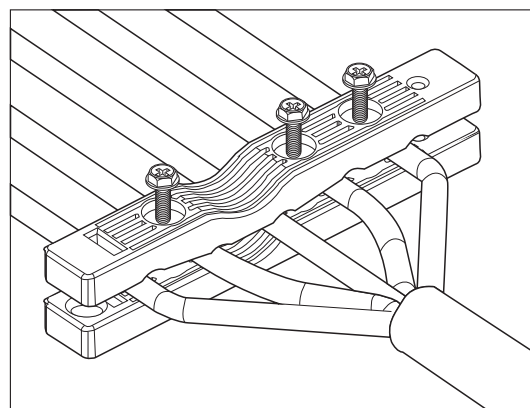

Fig.5-30

Then, use 3 pieces of M4 * 30 mm screws to secure the upper cover. At the same time, be careful not to screw it too tight. If you use excessive force to twist to the end, you may destroy the protection layer of the power cable.

NOTE

Do not connect the power cables of multiple outdoor units in series. The power cable of each outdoor unit must be drawn out by the power supply control box.

6 CONFIGURATION

6.1 Overview

This chapter describes how the system configuration can be implemented once the installation is complete, and other relevant information.

It contains the following information:











- Implement field settings
- Energy-saving and optimized operation
- Using the Leak Check function

INFORMATION

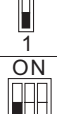
The installation personnel should read this chapter.



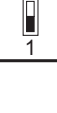





6.2 Dial Switch Settings

 means 0  means 1

S4		000	Zero static pressure (Factory default)
		001	Low static pressure mode (20Pa)
		010	Medium static pressure mode (40Pa)
		011	High static pressure mode (60Pa)
		100	Super high static pressure mode (80Pa)
S6-1		0	Reserved
S6-2		0	Only reverse cycle defrosting is allowed (default)
		1	Continuous heating and reverse cycle defrosting are allowed
S6-3		0	Reserved
S7		0	Reserved
S8-1		0	Reserved
S8-2		0	Start-up time is 12 minutes (default)
		1	Start-up time is 7 minutes
S8-3		0	Reserved
S9		0	No automatic dedusting (default)
		1	Auto dedusting(need customization)
S10		0	No forced commissioning(default)
		1	Force commissioning

S1-1 is ON, Forced implementation of old IDU protocol
S1-1 is OFF, Automatic selection of the new or old protocol (default)

S13		0	V6 communication protocol. (by default)
		1	V4+ communication protocol is forced. (Not recommended, ask it to Mundoclina)

ENC1		0-2	Outdoor unit address setting, Only 0, 1, 2 should be selected(default is 0), 0 is for master unit; 1, 2 are for slave units.
ENC2		0-5	Outdoor unit capacity setting, Only 0 to 5 should be selected, 0 to 5 are for 8HP to 18 HP.
ENC4		0-7	Outdoor unit network address setting, Only 0 to 7 should be selected. (default is 0)
ENC3 & S12		0-F	The number of indoor units is in the range 0-15.
		000	0-9 on ENC3 indicate 0-9 indoor units; A-F on ENC3 indicate 10-15 indoor units;
		0-F	The number of indoor units is in the range 16-31.
		001	0-9 on ENC3 indicate 16-25 indoor units; A-F on ENC3 indicate 26-31 indoor units.
		0-F	The number of indoor units is in the range 32-47.
		010	0-9 on ENC3 indicate 32-41 indoor units; A-F on ENC3 indicate 42-47 indoor units.
		0-F	The number of indoor units is in the range 48-63.
		011	0-9 on ENC3 indicate 48-57 indoor units; A-F on ENC3 indicate 58-63 indoor units.
		0	The number of indoor units is 64.
		100	
ENC5		0	Night silent time is 6h/10h.
		1	Night silent time is 6h/12h.
		2	Night silent time is 8h/10h.
		3	Night silent time is 8h/12h.
		4	No silent mode.(default)
		8	Silent mode.
		A	Super silent mode.
F	Set silent mode via centralized controller.		

6.3 Digital Display and Button Settings

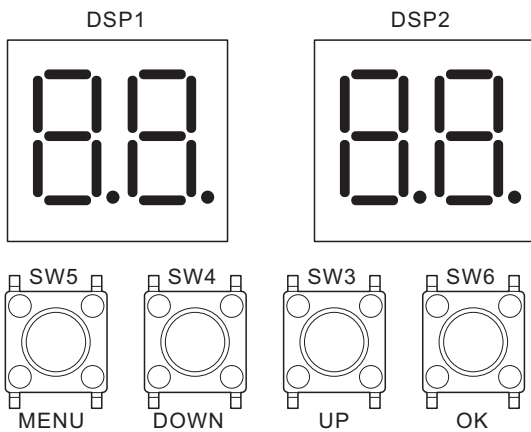

6.3.1 Digital display output

Outdoor unit state		Parameters displayed on DSP1	Parameters displayed on DSP2
Standby		Unit's address	The number of indoor units in communication with the outdoor units
Normal operation	For single compressor units		Running speed of the compressor in rotations per second
Error or protection		Placeholder and error or protection code	
In menu mode		Display menu mode code	
System check		Display system check code	

6.3.2 Function of buttons SW3 to SW6

Button	Function
SW3 (UP)	In menu mode: previous and next buttons for menu modes.
SW4 (DOWN)	Not in menu mode: previous and next buttons for system check information.
SW5 (MENU)	Enter / exit menu mode.
SW6 (OK)	Confirm to enter specified menu mode.

6.3.3 Menu mode

Only master unit has the full menu functions, slaves units only have error codes check and cleaning functions.

1. Long press SW5 "MENU" button for 5 seconds to enter menu mode, and the digital display displays "n1".
2. Press SW3 / SW4 "UP / DOWN" button to select the first level menu "n1", "n2", "n3", "n4" or "nb".
3. Press SW6 "OK" button to enter specified first level menu, for example, enter "n4" mode.
4. Press SW3 / SW4 "UP / DOWN" button to select the second level menu from "n41" to "n47".
5. Press SW6 "OK" button to enter specified second level menu, for example, enter "n43" mode.

CAUTION

- Operate the switches and push buttons with an insulated stick (such as a closed ball-point pen) to avoid touching of live parts.
- Querying external parameters and setting menu parameters are only allowed on the auxiliary module.
- The auxiliary module position is shown in the following figure.

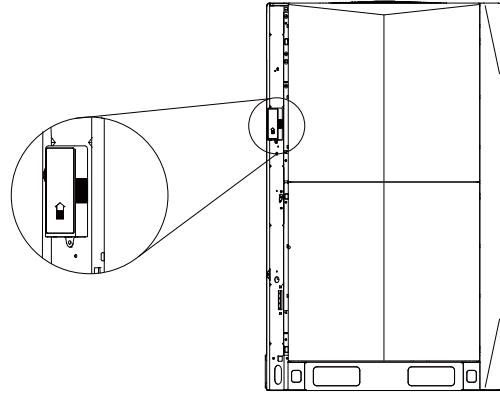
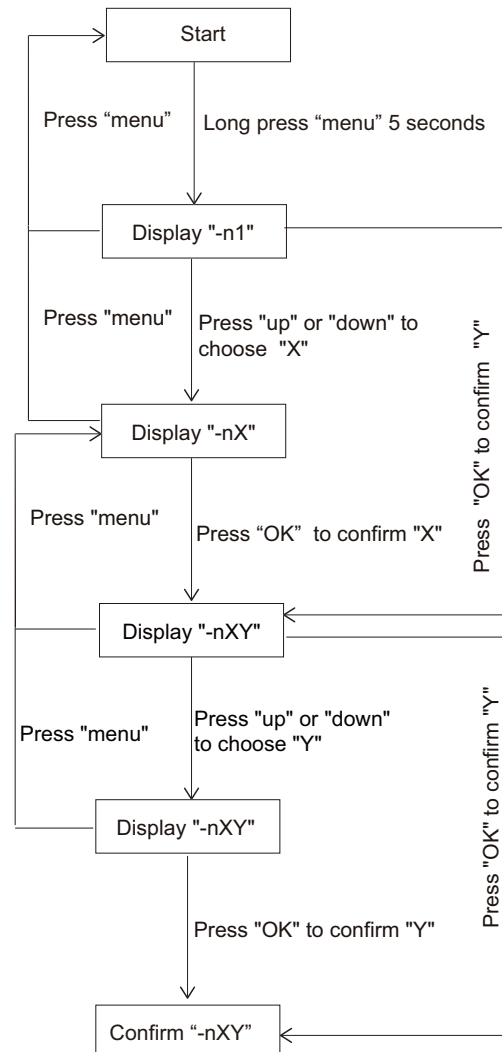

Fig.6-1

Menu mode selection flowchart:



MENU	Description	Note
n11	Test operation	①
n14	Cooling test	①
n15	Heating test	①
n16	Maintenance mode	①
n17	Manual defrost	①
n18	Automatic refrigerant diagnosis	①
n21	Refrigerant recovery 1 (PUMP DOWN)	①
n22	Refrigerant recovery 2 (PUMP OUT)	①
n25	Auto refrigerant charging	①
n27	Vacuuminizing mode	①
n31	Last fault code	
n32	Clear fault history	
n33	Fan software version	
n34	Restore factory default of menus.Valid for the master unit. (Except when snow-proofing and reverse rotation for dedusting)	①
n35	Release emergency stop	①
n41	Power limitation mode 1 (100%, default)	①
n42	Power limitation mode 2 (90%)	①
n43	Power limitation mode 3 (80%)	①
n44	Power limitation mode 4 (70%)	①
n45	Power limitation mode 5 (60%)	①
n46	Power limitation mode 6 (50%)	①
n47	Power limitation mode 7 (40%)	①
n91	Auto regulation of medium capacity (Tes0=6,default)	②
n92	Auto regulation of high capacity (Tes0=3)	②
n93	Auto regulation of low capacity (Tes0=9)	②
n94	Low locking capacity (Tes0=9)	②
n95	Medium-to-low locking capacity (Tes0=6)	③
n96	Medium locking capacity (Tes0=3)	③
n97	Medium-to-high locking capacity (Tes0=0)	③
n98	High locking capacity (Tes0=-3)	③
nA1	Auto regulation of medium capacity (Tcs0=48,default)	④
nA2	Auto regulation of high capacity (Tcs0=50)	④
nA3	Auto regulation of low capacity (Tcs0=45)	④
nA4	Low locking capacity (Tcs0=42)	④
nA5	Medium-to-low locking capacity (Tcs0=44)	⑤
nA6	Medium locking capacity (Tcs0=46)	⑤
nA7	Medium-to-high locking capacity (Tcs0=48)	⑤
nA8	High locking capacity (Tcs0=51)	⑤
nb1	Fahrenheit degree setting(°F)	①
nb2	Celsius degree setting(°C)(default)	①
nb5	Auto snow-blowing 1	①
nb6	Auto snow-blowing 2	①
nb7	Exit auto snow-blowing mode(default)	①
nb8	Setting of the VIP IDU address	①
nC1	Reverse rotation for dedusting. When this function is activated, ddOn is displayed. When this function is disabled, ddOF is displayed.	①
nC2	nC2=0: Remote shut down setting #1: System stops when the circuit (R-OFF1) is 'short'(default)	

MENU	Description	Note
nC2	nC2=1: Remote shut down setting #2: System stops when the circuit (R-OFF1) is 'open'	①
nC3	Start address for automatic addressing	①
nC4	Assign indoor unit addresses automatically	①
nC5	Display the online IDU address	①
nC7	Clear IDU address and MS address	①
nE1	Refrigerant leakage protection function 1	①
nE2	Refrigerant leakage protection function 2	①
nE3	Refrigerant leakage protection function 3	①

- ① Only available for master unit
- ② Only available for master unit (Te target temperature during cooling operation, Automatic control)
- ③ Only available for master unit (Te target temperature during cooling operation, Locking)
- ④ Only available for master unit (Tc target temperature during heating operation, Automatic control)
- ⑤ Only available for master unit (Tc target temperature during heating operation, Locking)

6.3.4 UP / DOWN system check button

Before pressing UP or DOWN button, allow the system to operate steadily for more than an hour. On pressing UP or DOWN button, the parameters listed in below table will be displayed in sequence.

Dsp1 content	Parameters displayed on DSP2	Remarks
--	Standby (ODU address + IDU Qty.)/frequency/particular state	
0	Outdoor unit modular configuration address	0-2
1	Single module capacity	8-18HP
2	Outdoor unit module Qty.	①
3	Indoor unit Qty. setting	①
4	Total system capacity	②
5	Single module compressor frequency	
6	System compressor frequency	③
7	System operation mode	④
8	Fan A step value	
9	Fan B step value	
10	Average T2 temperature(°C)	
11	Average T2B temperature(°C)	
12	Outdoor heat exchanger deicer temperature T3(°C)	
13	Outdoor air temperature T4(°C)	
14	Liquid pipe temperature T5(°C)	
15	Injection liquid temperature T6A(°C)	
16	Subcooling gas temperature T6B(°C)	
17	Compressor discharge temperature T7C1(°C)	
18	Outdoor heat exchanger gas pipe temperature T8(°C)	
19	Compressor inverter module internal temperature Ntc(°C)	
20	Heat Sink temperature T9(°C)	
21	Outdoor heat exchanger liquid pipe temperature TL(°C)	
22	Suction temperature T7(°C)	
23	Discharge superheated temperature (°C)	
24	Primary current	
25	EEV A Throttle Position	⑤
26	EEV C Throttle Position	⑥
27	High pressure (MPa)	⑦
28	Low pressure (MPa)	⑧
29	Online IDU Qty.	
30	Running IDU Qty.	①
31	Heat exchanger status	⑨
32	System startup status	⑩
33	Silent settings	⑪
34	Static pressure settings	⑫
35	TES(°C)	
36	TCS(°C)	⑬
37	DC Voltage	⑭
38	AC Voltage	⑮
39	Qty. of indoor units for cooling operation	
40	Qty. of indoor units for heating operation	
41	Qty. of HT hydro modules running	
42	Total capacity of indoor units for cooling operation	
43	Total capacity of indoor units for heating operation	
44	Total capacity of HT hydro modules running	
45	Fan's failure history	
46	Software version	
47	Power limitation mode settings	
48	Reserved	
49	Reserved	

Dsp1 content	Parameters displayed on DSP2	Remarks
50	Reserved	
51	Last recorded fault protection code	
--	--	

- ① Available for master unit.
- ② Only available for master unit, displayed on slave units has no sense.
- ③ Frequency: Actual value=Displayed value×10.
- ④ Operation mode: 0-OFF; 2-Cooling; 3-Heating; 5-Mixed cooling; 6-Mixed heating.
- ⑤ Opening angle of EEV: Actual value=Display value * 24.
- ⑥ Opening angle of EEV: Actual value=Display value * 4.
- ⑦ High pressure: Actual value=Display value * 0.1 MPa.
- ⑧ Low pressure: Actual value=Display value * 0.01 MPa.
- ⑨ Heat exchanger mode: 0-OFF; 1-Condenser; 2-Condenser(Not used); 3-Evaporator; 4-Evaporator(Not used).
- ⑩ System startup status: 2~4-Startup control; 6-PI control.
- ⑪ Silent settings: 0-Night silent time is 6h/10h; 1-Night silent time is 6h/12h; 2-Night silent time is 8h/10h; 3-Night silent time is 8h/12h; 4-No silent mode; 5-Silent mode; 6-Super silent mode.
- ⑫ Static pressure mode: 0-0 Pa; 1-20 Pa; 2-40 Pa; 3-60 Pa; 4-80 Pa.
- ⑬ Target temperature of condenser: Actual value=Display value-25.
- ⑭ DC voltage: Actual value=Display value * 10 V.
- ⑮ AC voltage: Actual value=Display value * 2 V.

7 COMMISSIONING

7.1 Overview

After installation, and once the field settings have been defined, the installation personnel is obliged to verify the correctness of the operations. Hence, you must follow the steps below to perform the test run.

This chapter describes how the test run can be carried out once the installation is complete, and other relevant information.

The test run usually includes the following stages:

1. Review the "Checklist Before Test Run".
2. Implement the test run.
3. If necessary, correct the errors before the test run completes with exceptions.
4. Run the system

7.2 Things to Note During Test Run

⚠ WARNING

During the test run, the outdoor unit operates at the same time with the MS boxes and indoor units connected to it. It is very dangerous to debug the MS boxes or indoor units during the test run.

Do not insert fingers, sticks, or other items into the air inlet or outlet. Do not remove the fan mesh cover. When the fan rotate is set a high speed, it may cause bodily injury.

💡 NOTE

Note that the required input power may be higher when this unit is run for the first time. This phenomenon is due to the compressor which needs to run for 50 hours before it can achieve a stable operating and power consumption state. Make sure the power supply is turned on 12 hours before operations so that the crankcase heater is properly energized. This is also to protect the compressor.

i INFORMATION

The test run can be carried out when the ambient temperature is within the required range as Fig.7-1.

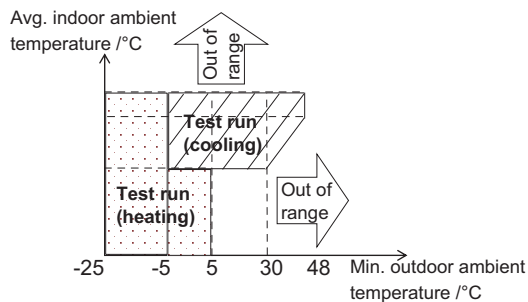

Fig.7-1

During the test run, the outdoor units, MS boxes and indoor units will start at the same time. Make sure all the preparations for the outdoor units, MS boxes and indoor units have been completed.

7.3 Checklist before Test Run

Once this unit is installed, check the following items first. After all the following checks have been completed, you must shut down the unit. This is the only way to start the unit again.

<input type="checkbox"/>	Installation Check if the unit is installed correctly to prevent strange noises and vibrations when the unit starts.
<input type="checkbox"/>	Field wiring Based on the wiring schematic and the relevant regulations, make sure the field wiring is based on the instructions described in section 5.10 on connecting wires.
<input type="checkbox"/>	Earth line Make sure the earth line is connected correctly, and the grounding terminal is tight.
<input type="checkbox"/>	Insulation test of main circuit Use the megameter of 500V, apply a voltage of 500V DC between the power terminal and the earth terminal. Check that the insulation resistance is above 2 MΩ. Do not use the megameter on the transmission line.
<input type="checkbox"/>	Fuses, circuit breakers, or protection devices Check that the fuses, circuit breakers, or locally installed protection devices comply with the size and type specified in section 4.4.2 on the requirements for safety devices. Make sure you use fuses and protection devices.
<input type="checkbox"/>	Internal wiring Visually inspect if the connections between the electrical component box and the interior of the unit is loose, or if the electrical components are damaged.
<input type="checkbox"/>	Piping dimensions and insulation Make sure the installation piping dimensions are correct, and the insulation work can be carried out normally.
<input type="checkbox"/>	Stop valve Make sure the stop valve is open on both the liquid, low pressure and high pressure gas sides.
<input type="checkbox"/>	Equipment damage Check for damaged components and extruded piping inside the unit.
<input type="checkbox"/>	Refrigerant leak Check for refrigerant leaks inside the unit. If there is a refrigerant leak, try to repair the leak. If the repair is not successful, please call the local agent. Do not come in contact with the refrigerant leaking from the refrigerant piping connections. It may cause frostbite.
<input type="checkbox"/>	Oil leak Check if there is oil leaking from the compressor. If there is an oil leak, try to repair the leak. If the repair is not successful, please call the local agent.
<input type="checkbox"/>	Air inlet/outlet Check for paper, cardboard or any other material that may obstruct the air inlet and outlet of the equipment.
<input type="checkbox"/>	Add additional refrigerant The amount of refrigerant to be added to this unit should be marked on the "Confirmation Table" which is placed at electrical control box front cover.
<input type="checkbox"/>	Installation date and field settings Make sure the installation date is recorded on the label of the electric control box cover, and the field settings are recorded as well.

7.4 About Test Run

The following procedures describe the test run of the whole system. This operation checks and determines the following items:

- Check if there is a wiring error (with the communication check of the indoor unit).
- Check if the stop valve is open.
- Determine the length of the pipe.

i INFORMATION

- Before you start the compressor, it may take 10 minutes to achieve a uniform cooling state.
- During the test run, the sound of the cooling mode in operation or the solenoid valve may become louder, and there may be changes in the displayed indicators. This is not a malfunction.

7.5 Test Run Implementation

1. Make sure all the settings you need to configure are completed. See section 6.2 on the implementation of the field settings.
2. Turn on the power supply of the outdoor unit, MS box and the indoor units.
3. Use the menu mode "n11" to enter the test run according to the method in section 6.3.3.

i INFORMATION

Make sure the power supply is turned on 12 hours before operations so that the crankcase heater is properly energized. This is also to protect the compressor.

7.6 Rectifications after Test Run is Completed with Exceptions

The test run is considered complete when there is no error code on the user interface or the outdoor unit display. When an error code is displayed, rectify the operation based on the description in the error code table. Try to conduct the test run again to check that the exception has been corrected.

i INFORMATION

Refer to the installation manual of the MS box and indoor unit respectively for details on other error codes related to the MS box and indoor unit.

7.7 Operating This Unit

Once the installation of this unit is completed, and the test run of the outdoor, MS boxes and indoor units is done, you can start to run the system.

The indoor unit user interface should be connected to facilitate the operations of the indoor unit. Please refer to the installation manual of the indoor unit for more details.

8 MAINTENANCE AND REPAIR

i INFORMATION

Arrange for the installation personnel or service agent to carry out one maintenance every year.

8.1 Overview

This chapter contains the following information:

- Take electrical hazards preventive measures during system maintenance and repair.

8.2 Safety Precautions for Maintenance

💡 NOTE

Before you carry out any maintenance or repair work, touch the metal parts of the unit to dissipate static electricity and protect the PCB.

8.2.1 Prevent electrical hazards

When maintaining and repairing the inverter:

1. Do not open the cover of the electrical component box within 5 minutes after the power is switched off.
2. Verify that the power supply is switched off before you use the measuring instrument to measure the voltage between the main capacitor and the main terminal ensure that the capacitor voltage in the main circuit is less than 36 VDC. the position of main terminal have be shown in the Wiring nameplate(The port of CN38 on the compressor drive board).
3. Before you come in any contact with the circuit board or components (including the terminals), make sure that static electricity in your own body is eliminated. You can touch the sheet metal of the outdoor unit to achieve this. If conditions permit, please wear anti-static bracelet.
4. During maintenance, pull out the plug connecting to the power cord of the fan to prevent the fan from rotating when it is windy outside. The strong winds will cause the fan to rotate and generate electricity which can charge the capacitor or terminals, leading to an electric shock. At the same time, do take note of any mechanical damage. The blades of a high speed rotating fan are very dangerous and cannot be operated by one person alone.
5. Once the maintenance is completed, remember to reconnect the plug to the terminal; otherwise, a fault will be reported for the main control board.
6. When the unit is power on, the fan of the unit with auto snow-blowing function will run periodically, so make sure the power supply is off before touching the unit.

Please refer to the wiring schematic on the back of the box cover of the electrical component box for the relevant details.

9 ERROR CODES

Table 9-1: Error code table

Displayed content	Error or protection definition	Remarks
E0	Communication error between outdoor units	Only displayed on the slave unit with the error
E2	Communication error between MS and master unit	Only displayed on the the master unit
E4	T3/T4 temperature sensor error	Displayed on the unit with the error
E5	Abnormal power supply voltage	Displayed on the unit with the error
E7	Discharge temperature sensor error (T7C1)	Displayed on the unit with the error
E8	Outdoor unit address error	Displayed on the unit with the error
E9	EEPROM mismatch of compressor	Displayed on the unit with the error
F1	DC bus voltage error	Displayed on the unit with the error
F3	T6B temperature sensor error	Displayed on the unit with the error
F5	T6A temperature sensor error	Displayed on the unit with the error
zF6	Electronic expansion valve connection error	Displayed on the unit with the error
F9	T5 temperature sensor error	Displayed on the unit with the error
FA	T8 temperature sensor error	Displayed on the unit with the error
Fb	T9 temperature sensor error	Displayed on the unit with the error
Fc	TL temperature sensor error	Displayed on the unit with the error
Fd	T7 temperature sensor error	Displayed on the unit with the error
H0	Communication error between main board and compressor drive board	Displayed on the unit with the error
H2	Qty. of outdoor unit decreases error	Only displayed on the the master unit
H3	Qty. of outdoor unit increases error	Only displayed on the the master unit
H4	Compressor inverter module protection	Displayed on the unit with the error
H5	Low pressure protection lock out (P2 3X in 60 minutes)	Displayed on the unit with the error
H6	Compressor discharge temperature protection (P4 3X in 100 minutes)	Displayed on the unit with the error
H7	Qty. of indoor units mismatching	Only displayed on the the master unit
H8	High pressure sensor error	Displayed on the unit with the error
xH9	DC fan module protection (P9 10X in 120 minutes)	Displayed on the unit with the error
Hb	Low pressure sensor error	Displayed on the unit with the error
yHd	Slave unit malfunction(y=1,2 ,1Hd stands for slave unit 1 error)	Only displayed on the the master unit
C7	Compressor inverter module temperature protection (PL 3X in 100 minutes)	Displayed on the unit with the error
P1	High pressure protection	Displayed on the unit with the error
P2	Low pressure protection	Displayed on the unit with the error
P31	Primary current protection	Displayed on the unit with the error
P32	Secondary current protection	Displayed on the unit with the error
P4	Discharge temperature protection or discharge temperature switch protection	Displayed on the unit with the error
U0	In the event of S10=ON, a forced test operation is set. However, a test operation is not performed for 30 minutes after power-on	Displayed on the unit with the error
xP9	DC fan module protection	Displayed on the unit with the error
PL	Compressor inverter module temperature protection	Displayed on the unit with the error
PP	Compressor discharge insufficient superheat protection	Displayed on the unit with the error
A0	Emergency stop	Displayed on the unit with the error
A1w	Refrigerant leakage protection	Displayed on the unit with the error
CA2	The system is connected to VRF DX AHU control box only	Displayed on the unit with the error
CA3	The system is connected only to the HT hydro module	Displayed on the unit with the error
CA4	The system is only connected to VRF DX AHU control box + HT hydro module	Displayed on the unit with the error
CA5	The system is simultaneously connected to VRF indoor + VRF DX AHU control box + HT hydro module	Displayed on the unit with the error
Cb1	VRF indoor is beyond the connection range	Displayed on the unit with the error
Cb2	VRF DX AHU control box is beyond the connection range	Displayed on the unit with the error
Cb3	The HT hydro module is beyond the connection range	Displayed on the unit with the error
Cb4	The Qty. of IDUs connected to the system is beyond the connection range	Displayed on the unit with the error
L0	Inverter compressor module error	
L1	DC bus low voltage protection	

Displayed content	Error or protection definition	Remarks
L2	DC bus high voltage protection	
L3	Reserved	
L4	MCE error	
L5	Zero speed protection	
L6	Motor parameter error	
L7	Phase sequence error	
L8	Compressor frequency hopping error	
LA	PED software verification failed	

Note:

- 'x' is a placeholder for the fan address, with 1 representing fan A and 2 representing fan B.
- 'y' is a placeholder for the address (1 or 2) of the slave unit with the error.
- 'z' is a number for the electronic expansion valve, with 1 representing electronic expansion valve A and 3 representing electronic expansion valve C.
- 'w' is a placeholder for the protection mode of refrigerant leakage, with 1 representing the system should force to shutdown after the protection, 2 representing the system should force to shutdown after the protection in 12 hours and 3 representing the system should force to shutdown after the protection in 24 hours.

10 DISPOSAL

The dismantling of the unit, and treatment of the refrigerant, lubricating oil and other components must be carried out in accordance with the applicable law.

11 TECHNICAL DATA

11.1 Dimensions

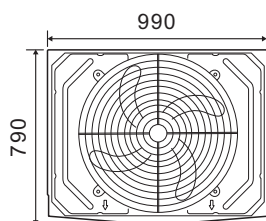
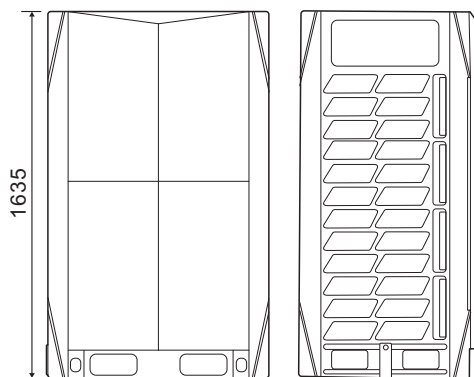

8~12 HP Unit:mm

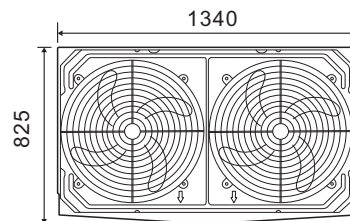
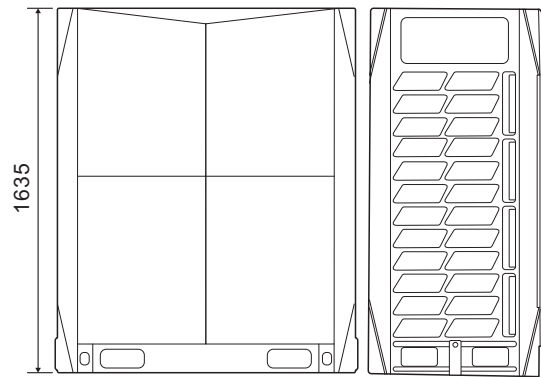

14~18 HP Unit:mm

11.2 Maintenance Space: Outdoor Unit

Make sure there is sufficient space around the unit for maintenance work, and the minimum space for air inlet and air outlet is reserved (see below to select a feasible method).

NOTE

- Ensure enough space for maintenance. The units in the same system must be at the same height.
- Outdoor units must be spaced such that sufficient air may flow through each unit. Sufficient airflow across heat exchangers is essential for outdoor units to function properly.

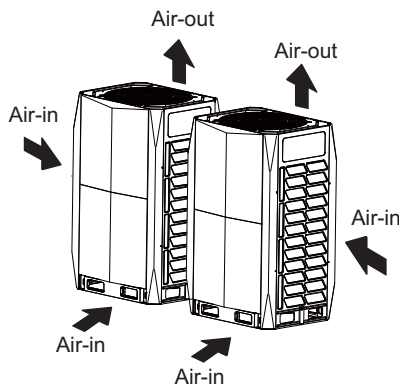

- For single row installation

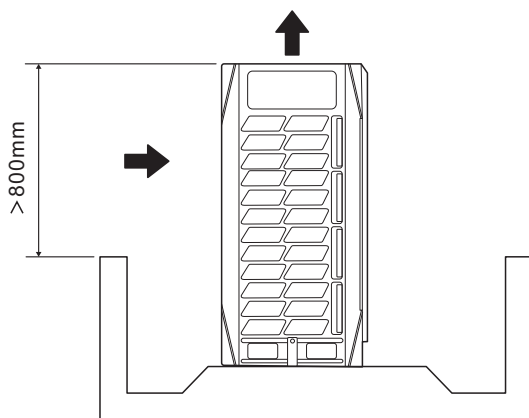
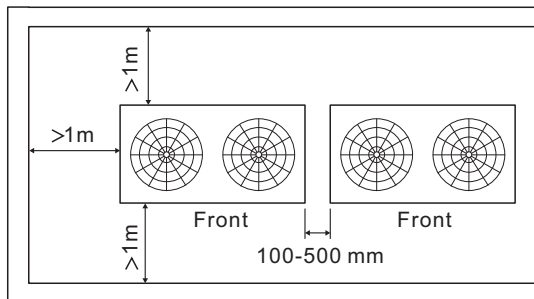

- For multi-row installation

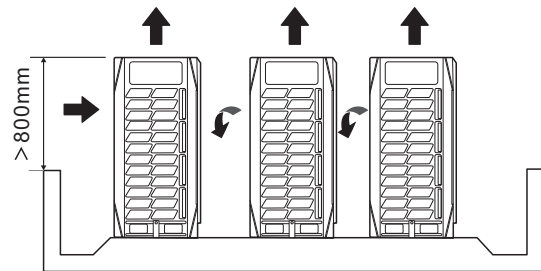
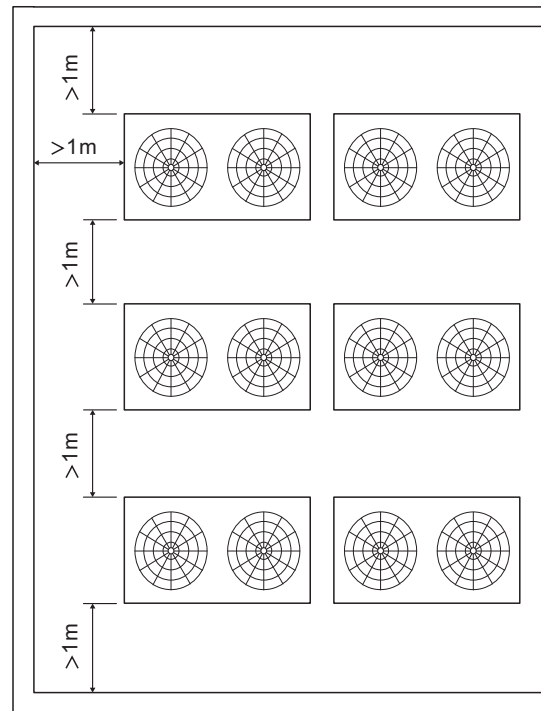

If obstacles are around the outdoor unit, they must be 800mm below the top of the outdoor unit. Otherwise, a mechanical exhaust device must be added.

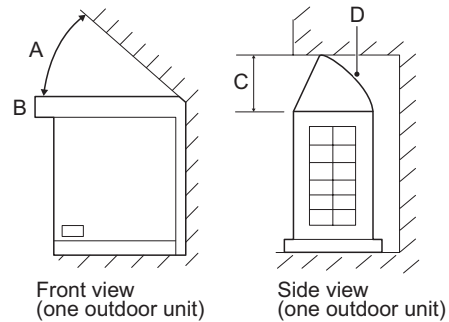

Front view (one outdoor unit)

Side view (one outdoor unit)

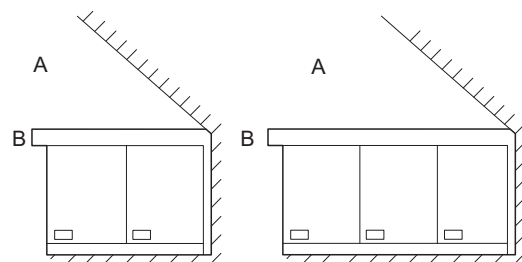

Front view (two outdoor units combined)

Front view (three outdoor units combined)

A >45° B >300 mm C >1000 mm D Airflow deflector

If the particular circumstances of an installation require a unit to be placed closer to a wall. Depending on the height of adjacent walls relative to the height of the units, ducting may be required to ensure proper air discharge. In the situation depicted, the vertical section height of ducting should be at least $H-h$.

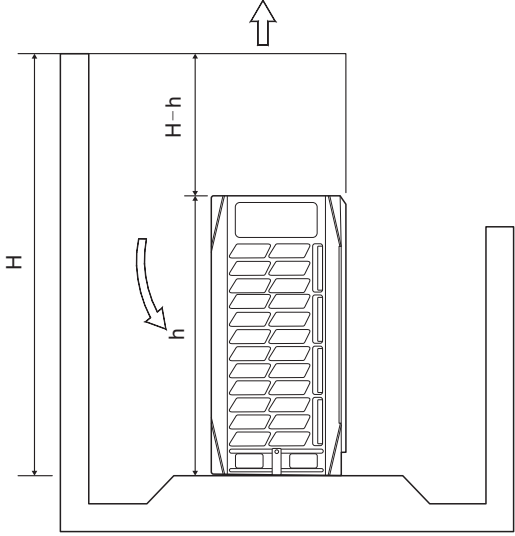

11.3 Component Layout and Refrigerant Circuits

8-12HP

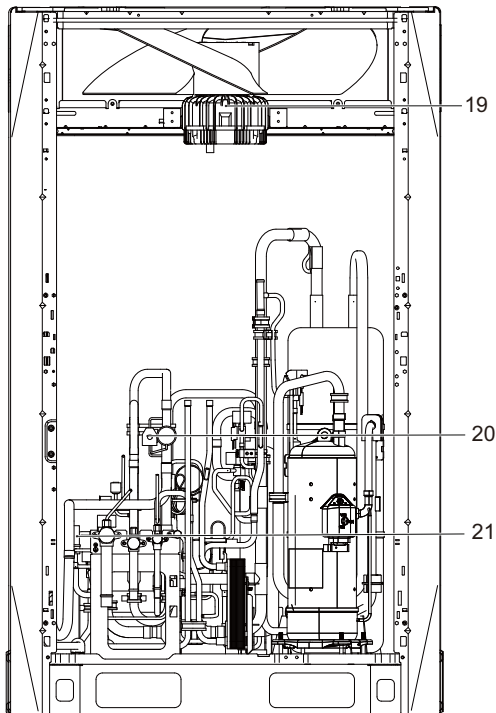
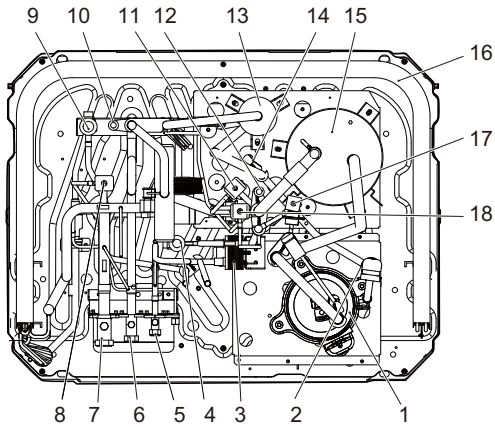
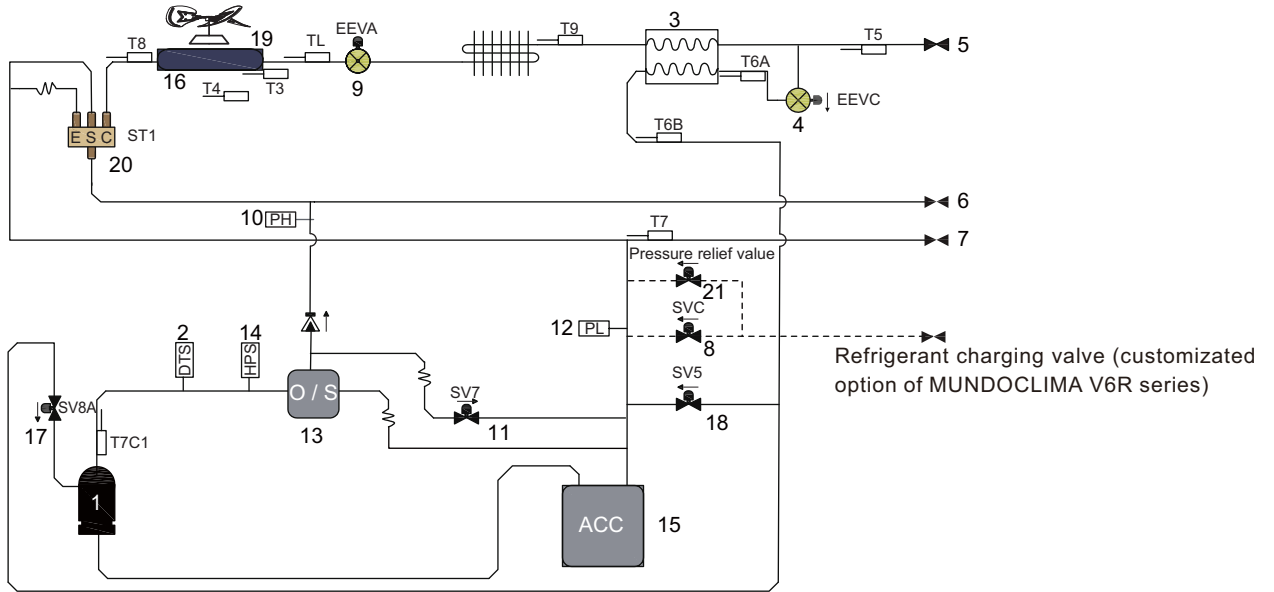

1	Inverter compressor
2	Discharge temperature switch
3	Plate heat exchanger
4	Electronic expansion valve EEVC
5	Stop valve (liquid side)
6	Stop valve (high pressure gas side)
7	Stop valve (low pressure gas side)
8	Refrigerant charge solenoid valve(SVC)
9	Electronic expansion valve EEVA
10	High pressure sensor
11	Hot gas bypass solenoid valve(SV7)
12	Low pressure sensor
13	Oil separator
14	High pressure switch
15	Gas-liquid separator
16	Heat exchanger
17	Injection solenoid valve(SV8A)
18	Injection bypass solenoid valve(SV5)
19	Inverter fan A
20	4-way valve
21	Pressure relief value

T3	Heat exchanger deicer temperature sensor
T4	Outdoor air temperature sensor
T5	Liquid pipe temperature sensor
T6A	Injection liquid temperature sensor
T6B	Subcooling gas temperature sensor
T7	Suction temperature sensor
T8	Heat exchanger gas temperature sensor
T9	Heat sink temperature sensor
TL	Heat exchanger liquid temperature sensor
T7C1	Compressor discharge temperature sensor

14-18HP

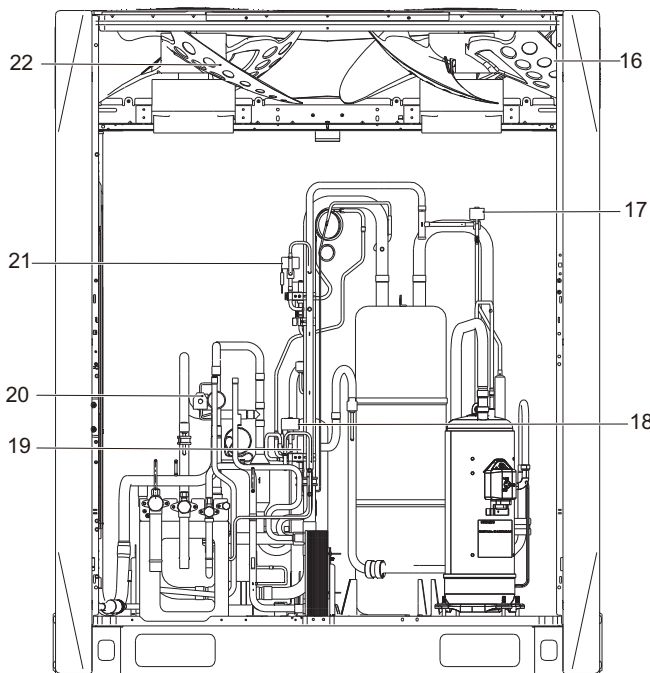
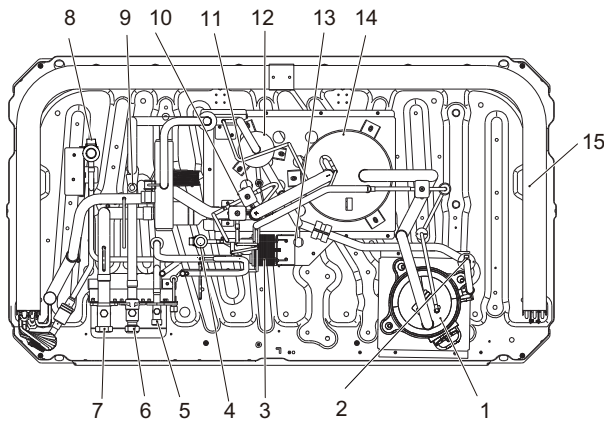
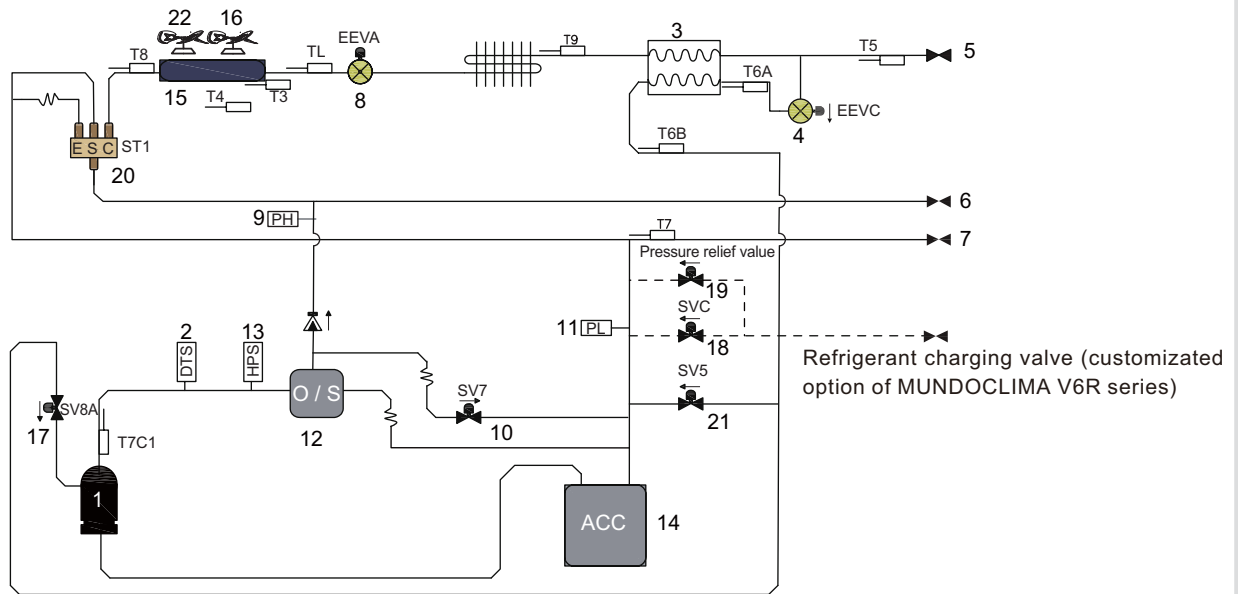

1	Inverter compressor
2	Discharge temperature switch
3	Plate heat exchanger
4	Electronic expansion valve EEVC
5	Stop valve (liquid side)
6	Stop valve (high pressure gas side)
7	Stop valve (low pressure gas side)
8	Electronic expansion valve EEVA
9	High pressure sensor
10	Hot gas bypass solenoid valve (SV7)
11	Low pressure sensor
12	Oil separator
13	High pressure switch
14	Gas-liquid separator
15	Heat exchanger
16	Inverter fan B
17	Injection solenoid valve (SV8A)
18	Refrigerant charge solenoid valve (SVC) (customization option)
19	Pressure relief value
20	4-way valve
21	Injection bypass solenoid valve (SV5)
22	Inverter fan A

T3	Heat exchanger deicer temperature sensor
T4	Outdoor air temperature sensor
T5	Liquid pipe temperature sensor
T6A	Injection liquid temperature sensor
T6B	Subcooling gas temperature sensor
T7	Suction temperature sensor
T8	Heat exchanger gas temperature sensor
T9	Heat sink temperature sensor
TL	Heat exchanger liquid temperature sensor
T7C1	Compressor discharge temperature sensor

11.4 Fan Performance

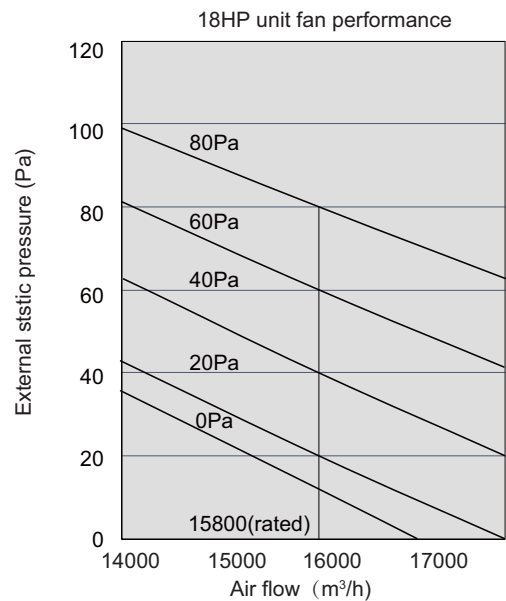
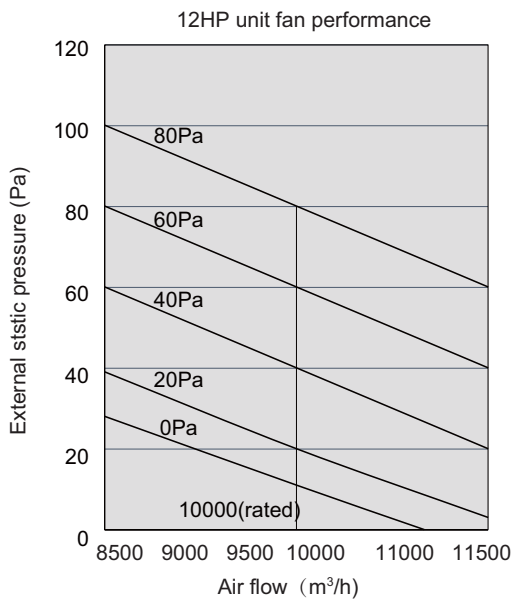
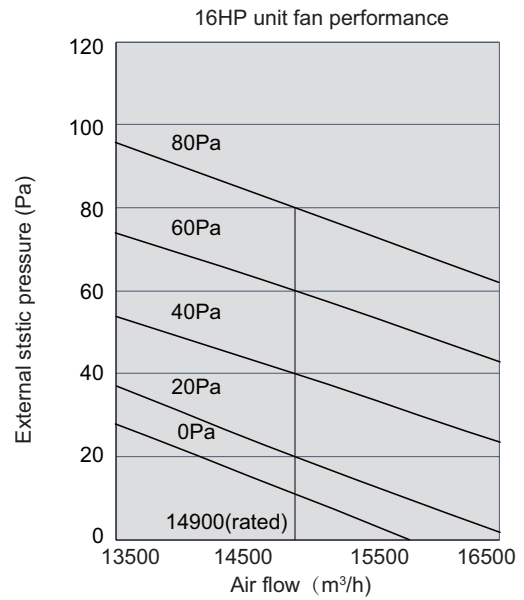
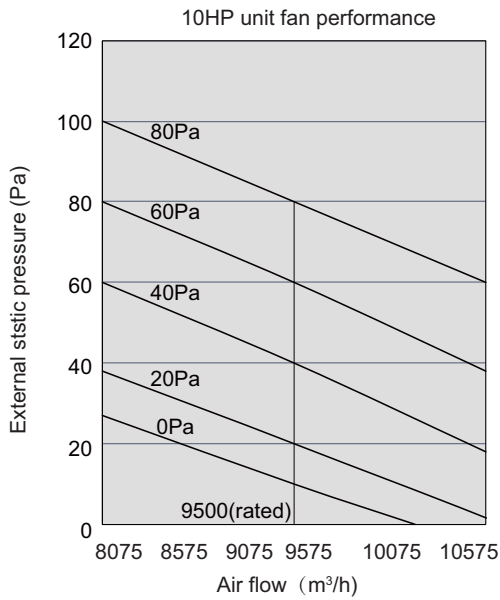
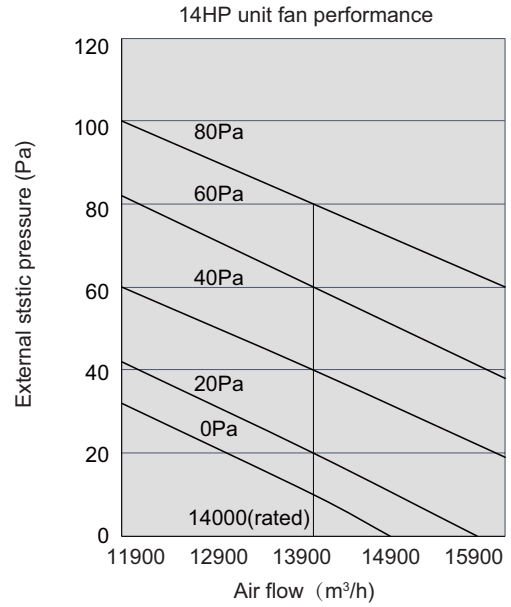
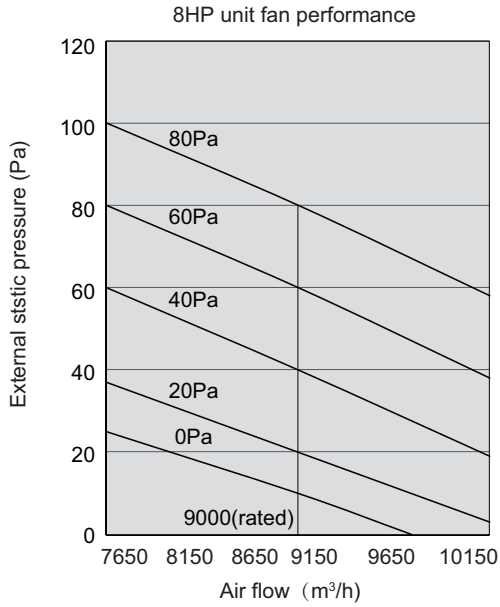

11.5 Outdoor Unit Ducting

Outdoor unit ducting design should take account of the following:

1. Before installing outdoor unit ducting, be sure to remove the unit's steel mesh cover, otherwise airflow will be adversely affected.
2. Each duct should contain no more than one bend.
3. Vibration isolation should be added to the connection between the unit and the ducting to avoid vibration/noise.
4. Installing louvers is required as doing for safety, they should be installed at an angle no greater than 15° to the horizontal, to minimize the impact on airflow.
5. If more than one outdoor units need ducting, each outdoor unit should has independent ducting, it cannot share one ducting for more than one outdoor units.
6. According to the actual static pressure of the outdoor unit ducting, an appropriate static pressure mode should be set through "S4" dial code.

Ducting for 8-12HP

Option A – Transverse ducting (unit: mm)

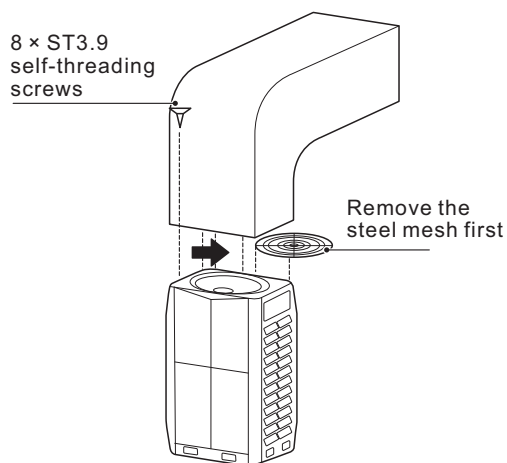
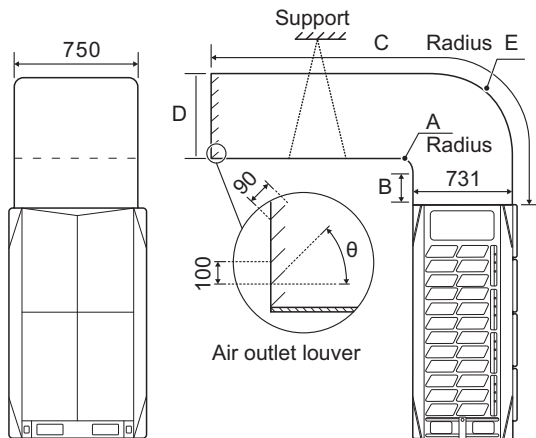

A	$A \geq 300$
B	$B \geq 250$
C	$C \leq 3000$
D	$D \geq 731$
E	$E = A + 731$
θ	$\theta \leq 15^\circ$

Option B – Longitudinal ducting (unit: mm)

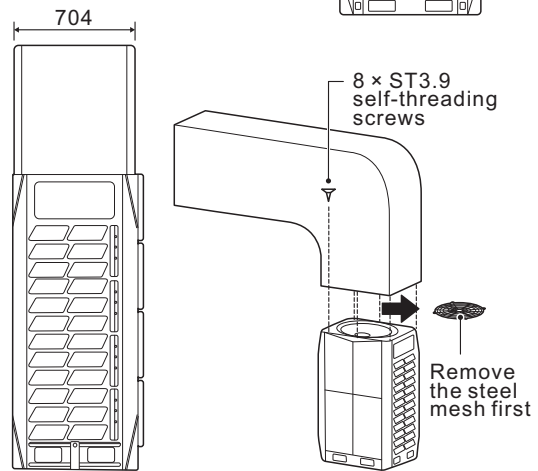
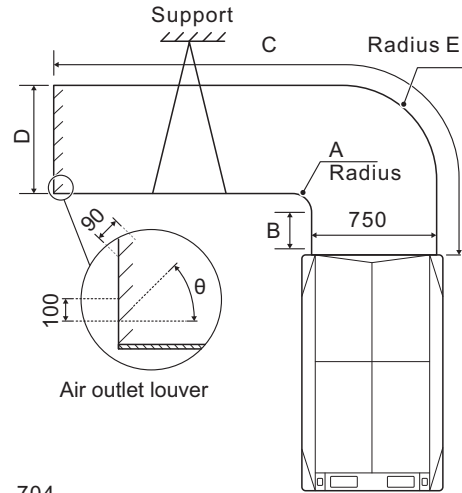

A	$A \geq 300$
B	$B \geq 250$
C	$C \leq 3000$
D	$D \geq 750$
E	$E = A + 750$
θ	$\theta \leq 15^\circ$

ESP(Pa)	Remarks
0Pa	Factory default
0-20Pa	Remove steel mesh and connect to duct<3m long
20-80Pa	Dial switch S4 setting

Ducting for 14-18HP

Option A – Transverse ducting (unit: mm)

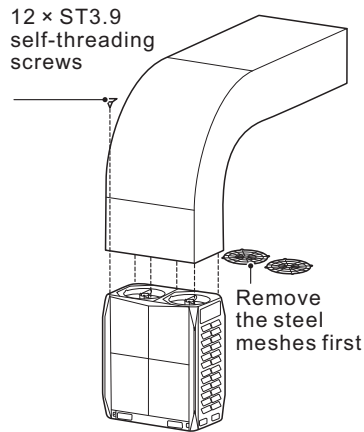
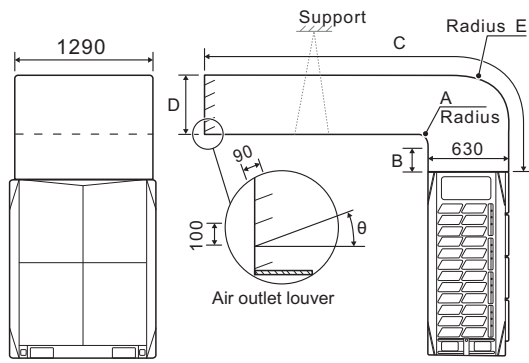

A	$A \geq 300$
B	$B \geq 250$
C	$C \leq 3000$
D	$D \geq 630$
E	$E = A + 630$
θ	$\theta \leq 15^\circ$

Option B – Longitudinal ducting (unit: mm)

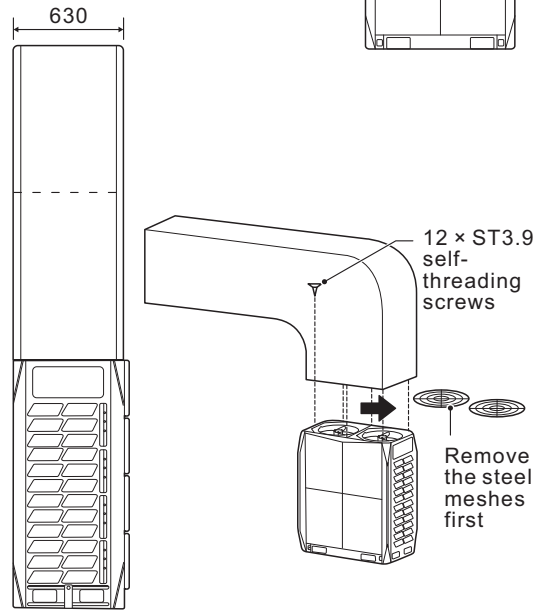
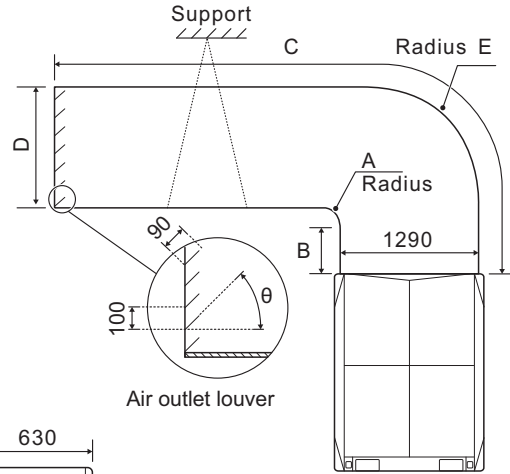

A	$A \geq 300$
B	$B \geq 250$
C	$C \leq 3000$
D	$D \geq 1290$
E	$E = A + 1290$
θ	$\theta \leq 15^\circ$

ESP(Pa)	Remarks
0Pa	Factory default
0-20Pa	Remove steel mesh and connect to duct<3m long
20-80Pa	Dial switch S4 setting

12 AUTOMATIC REFRIGERANT CHARGING GUIDELINE

12.1 Preconditions

- 1) The outdoor units should be customized for auto refrigerant charging function (MUNDOCLIMA MVD V6R units are).
- 2) The auto refrigerant charging function is invalid when any of the following conditions are met:
 - The minimum outdoor ambient temperature is below 0°C or greater than 43°C.
 - The average indoor ambient temperature is below 15°C or greater than 32°C.
 - There are some high temperature (HT) hydro modules in the system.
- 3) Only charge refrigerant after performing a gas tightness test and vacuum drying.

12.2 Procedure

- 1) Open outdoor units' liquid pipe stop valve, low pressure and high pressure gas pipe stop valves.
- 2) Confirm the R410A refrigerant amount is enough for system charging in the refrigerant tank.
- 3) Open the lid of the outdoor unit's refrigerant auto gauge point, and connect the refrigerant tank to it. If it is a multi-outdoor unit system, connect the refrigerant tank to the master unit's auto gauge point

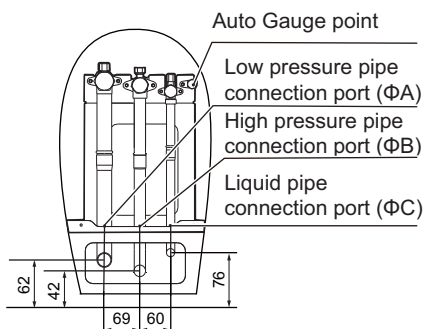
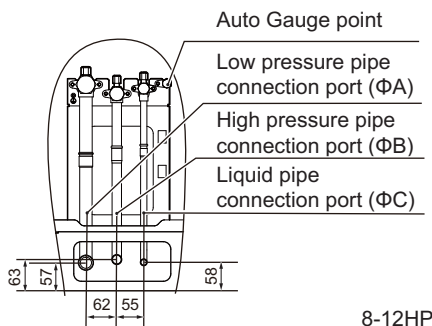

- 4) The system should be powered on no less than 12 hours. And all outdoor units, mode selection (MS) boxes and indoor units have no error or protection code.
- 5) Long press SW5 "MENU" button for 5 seconds on master unit to enter menu mode, and the digital display displays "-n1", then press SW3/SW4 "UP/DOWN" button to select the first level menu. When the digital display displays "-n2", press SW6 "OK" button to confirm, then press SW3/SW4 "UP/DOWN" button to select the second level menu. When the digital display displays "-n25", press SW6 "OK" button to confirm, and the digital display displays "r005" if all the prerequisites are met. Now the system is in auto refrigerant charging mode.

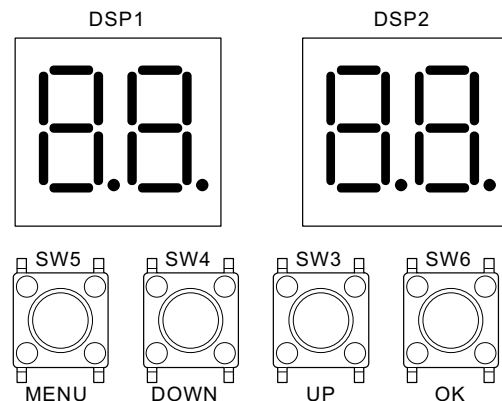

- 6) The auto refrigerant charging has two stages: charging in standby mode and charging in operation mode.
 - i. 1st stage: auto refrigerant charging in standby mode

When the system pressure achieves target pressure, all the indoor units in the system will run in cooling test mode.
 - ii. 2nd stage: auto refrigerant charging in operation mode

All the indoor units will run in cooling test mode. At this time, the remote controller cannot

control the indoor units and the indoor unit will not stop running even if it reaches the set temperature.

- 7) When the system achieves any of below conditions, the system will exit "r005" mode:
 - a. Auto refrigerant charging is finished.
 - b. The system displays error or protection code.
 - c. Reaches 240 minutes.
 - d. Long press "OK" button more than 5 seconds.

If the system exits "r005" mode for condition "b", please solve the problem and enter "r005" mode again. If the system exit "r005" mode for condition "c", please enter "r005" mode again to recharge the refrigerant.

Cautions:

- 1) The refrigerant auto gauge point is connected to the piping inside the outdoor unit. The outdoor unit's internal piping is already factory charged with refrigerant, so be careful when connecting the charge hose.
- 2) After adding the refrigerant, do not forget to close the lid of the refrigerant auto gauge point.

Note:

- 1) The digital display will displays "rAF1" if the outdoor ambient temperature is out of range. The digital display will displays "rAF2" if the indoor ambient temperature is out of range. And the digital display will display "rAF3" if some high temperature (HT) hydro modules are connected to the system.
- 2) In "r005" mode, please keep the refrigerant tank connects to the master unit and avoid the refrigerant tank is empty.
- 3) Record the additional refrigerant amount on the confirmation table of the electronic control box cover.
- 4) For a multi-outdoor unit system, it is

recommended to calculate the required additional refrigerant manually according to the additional refrigerant charge rules (refer to the outdoor unit installation manual).

OWNER'S MANUAL - CONTENTS

1 OVERVIEW	
• 1.1 Meaning of Various Labels	50
2 SYSTEM INFORMATION	50
3 USER INTERFACE	50
4 BEFORE OPERATING	50
5 OPERATIONS	
• 5.1 Operating Range	51
• 5.2 Operating System	51
• 5.3 Using the Dry Program	52
6 MAINTENANCE AND REPAIR	
• 6.1 Maintenance after Unit has been Shut Down for a Long Period	52
• 6.2 Maintenance Before Unit is Shut Down for a Long Period	52
• 6.3 About the Refrigerant	53
• 6.4 After-sales Service and Warranty	53
7 TROUBLESHOOTING	
• 7.1 Error Code: Overview	54
• 7.2 Fault Symptom: Non Air Conditioning Issues	56
8 CHANGE INSTALLATION SITE	57
9 DISPOSAL	57

1 OVERVIEW

1.1 Meaning of Various Labels

The precautions and things to note in this document involve very important information. Please read them carefully.

WARNING

A situation that may lead to severe injury or death.

CAUTION

A situation that may lead to mild or moderate injury.

NOTE

A situation that may cause damage to the equipment or loss of property.

INFORMATION

Indicates a useful hint or additional information.

2 SYSTEM INFORMATION

INFORMATION

The equipment must be operated by professionals or trained people, and it is mainly used for commercial purposes such as stores, shopping malls and large office buildings.

This unit can be used for heating/cooling.

NOTE

- Do not use the air conditioning system for other purposes. In order to avoid quality degradation, do not use the unit to cool precision instruments, food, plants, animals or works of art.
- For system maintenance and expansion, please contact professional staff.

3 USER INTERFACE

CAUTION

- Please contact the agent if you need to check and adjust the internal components.
- The figure shown in this manual is for reference only and may be slightly different from the actual product.

This operation manual only provides information on the main functions of this system.

4 BEFORE OPERATING

WARNING

- This unit consists of electrical components and hot parts (danger of electric shock and scald).
- Before you operate this unit, make sure that the installation personnel have installed it properly.
- This appliance can be used by children aged from 8 years and above and persons with reduced physical, sensory or mental capabilities or lack of experience and knowledge if they have been given supervision or instruction concerning use of the appliance in a safe way and understand the hazards involved.
- Children shall not play with the appliance.
- Cleaning and user maintenance shall not be made by children without supervision.

CAUTION

- The air outlet must not be directed at any human body as it is not conducive to the person's health to be exposed to long periods of moving cold/hot air.
- If the air conditioner is used together with a device that comes with a burner, make sure the room is fully ventilated to prevent anoxia (oxygen insufficiency).
- Do not operate the air conditioner when applying fumigated insecticide in the room. This may cause chemicals to be deposited inside the unit, and pose a danger to the health of people allergic to chemicals. This unit should only be serviced and maintained by a professional air conditioning service engineer. Incorrect servicing or maintenance can cause electric shock, fire or leakage of water. Contact your dealer for servicing and maintenance.
- A-weighted sound pressure of all the units level are all below 70 dB. This appliance is not intended for use by persons (including children) with reduced physical, sensory or mental capabilities, or lack of experience and knowledge, unless they have been given supervision or instruction concerning use of the appliance by a person responsible for their safety.
- Cleaning and user maintenance shall not be made by children without supervision.
- The appliance shall be installed in accordance with national wiring regulations.
- This appliance is intended to domestic and used by expert or trained users in shops, in light industry and on farms, or for commercial use by lay persons.

This operation manual is suitable for air conditioning systems with standard controls. Before you start the system, please contact the agent for information on the things to note when operating the system. If the installed unit has a custom control system, please ask the agent

for information on the things to note when operating the system. Operating modes of the outdoor unit (depends on the indoor unit):

- Cooling.
- Heatling.
- Mix cooling & heating.

Specialized functions vary with the type of indoor unit. Refer to the installation/user manuals for more information.

- Unit is marked with the following symbols:



This symbol indicates that electrical and electronic products must not be mixed with unsorted household waste. Do not attempt to dismantle the system on your own. All works involved in dismantling the system, handling the refrigerant, oil and other components must be carried out by authorized installation personnel, and the works must be carried out in accordance with the applicable law. The unit must be disposed of and treated at special treatment facilities for reuse, and recycling. By making sure that this product is properly handled and disposed of, you help to minimize the negative impact on the environment and human health. For more information, please contact the installation personnel or local organization.

5 OPERATIONS

5.1 Operating Range

	Cooling mode	Heating mode
Outdoor temperature	-5 (-15 ¹)~52°C (DB)	-25~19°C (WB)
Indoor temperature	15~24°C (WB)	15~30°C (DB)
Indoor humidity	≤ 80% ²	
	Mix cooling & heating mode	
	Main cooling	Main Heating
Outdoor temperature	-5 (-15 ¹)~27°C (DB)	-5 (-15 ¹)~19°C (WB)
Indoor temperature	Cooling:15~24°C (WB) Heaing:15~30°C (DB)	Cooling:15~24°C (WB) Heaing:15~30°C (DB)
Indoor humidity	≤ 80% ²	

Notes:

1. -15°C cooling is possible only with the single MS box, otherwise, the minimum allowable cooling operating temperature is -5°C.
2. Condensation will form on the unit surface and water dripping out of the unit when the indoor humidity is beyond 80%.
3. The operating range is for VRF indoor units. There will be some differences when high temperature (HT) hydro modules are connected to the system.

NOTE

The temperature should below 55°C during transporing. The safety device will be triggered if the temperature or humidity exceeds these conditions, and the air conditioner may not run.

5.2 Operating System

5.2.1 About the system operations

The operating program varies with different combinations of outdoor unit and controller.

To protect this unit, please turn on the main power supply 12 hours before you start to operate this unit.

If there is a power outage while the unit is running, the unit will automatically restart its operation when the power supply resumes.

5.2.2 Cooling and heating operation of inverter central A/C

The indoor units of this air conditioner can be controlled separately. And the indoor units in the same system can operate in cooling and heating modes simultaneously.

However, the indoor units connected to the same port of the mode selection (MS) box cannot operate in heating and cooling modes simultaneously. Under such cases:

1. If the first turned on indoor unit is operated in cooling mode, indoor units turned on thereafter in the heating mode will display the "E0" (mode conflict).
2. If the first turned on indoor unit is operated in heating mode, indoor units turned on thereafter in the cooling or fan mode will display the "E0" (mode conflict).

5.2.3 About the heating operation

Compared to the cooling operation, the heating operation takes a longer time.

Need to perform the following operations to prevent the heating capacity from dropping or prevent cold air from coming out of the system.

Defrost Operation

In the heating operation, as the outdoor temperature decreases, frost may be formed on the heat exchanger in the outdoor unit, making it more difficult for the heat exchanger to heat up the air. The heating capacity decreases, and a defrosting operation needs to be performed on the system in order for the system to provide sufficient heat to the indoor unit. At this point, the indoor unit will show the defrost operation on the display screen.

The indoor fan motor will automatically stop running so as to prevent cold air from coming out of the indoor unit when the heating operation starts. This process will take some time. This is not a malfunction.

INFORMATION

- When there is a drop in the external temperature, the heating capacity decreases. If this happens, please use another heating equipment and unit at the same time. (Make sure the room is well ventilated if you are using an equipment that produces fire.) Do not place any equipment that may produce a fire where the air outlets of the unit are or below the unit itself.
- Once the unit starts, it takes some time for the room temperature to rise, as the unit uses a hot air circulation system to heat the room.
- If the hot air rises to the ceiling, causing the ground area to become cold, it is recommended that you use a circulating device (to circulate the indoor air). Please contact the agent for details.

5.2.4 Operating system

1. Press the "switch" button on the controller.
Result: The running light turns on and the system starts to run.

2. Repeatedly press the mode selector on the controller to select the required operation mode.

Stop

Press the "switch" button on the controller again.

Result: The running light is now off, and the system stopped running.

NOTE

Once the unit has stopped running, do not disconnect the power immediately. Wait for at least 10 minutes.

Adjust

Refer to the user manual for the controller on how to set the required temperature, fan speed and air flow direction.

5.3 Using the Dry Program

5.3.1 About the system operations

The function in this program uses the minimum temperature drop (minimum indoor cooling) to bring about a drop in humidity in the room.

In the drying process, the system automatically determines the temperature and fan rotation speed (cannot use the user interface to implement the settings).

5.3.2 Using the dry program

Start

1. Press the switch button on the controller.
Result: The running light turns on and the system starts to run.

2. Repeatedly press the mode selector on the controller.

3. Press the button to adjust the air flow direction (this function is not available for all indoor units).

Stop

4. Press the switch button on the user interface again.
Result: The running light is now off, and the system stopped running.

WARNING

Do not touch the air outlet or the horizontal blade when operating in the fan swing mode. Your fingers may be caught in the unit or the unit may be damaged.

6 MAINTENANCE AND REPAIR

NOTE

- Do not check or repair the unit on your own. Please get relevant professionals to conduct any check or repairs.

Do not use substances like gasoline, diluent, and chemical dust cloth to wipe the operations panel of the controller. This may remove the surface layer of the controller. If the unit is dirty, immerse a cloth in diluted and neutral detergent, squeeze it dry, and then use it to clean the panel. Finally, wipe it with a dry cloth.

WARNING

- When the fuse melts, do not use any unspecified fuse or other wire to replace the original fuse. The use of electrical wires or copper wires may cause the unit to malfunction or cause a fire.
- Do not insert fingers, sticks, or other items into the air inlet or outlet. Do not remove the fan mesh cover. When the fan rotates at a high speed, it may cause bodily injury.
- It is very dangerous to check the unit when the fan is rotating. Make sure you turn off the main switch before any maintenance work begins.
- Do check the supporting and base structure of the unit for any damages after a long period of use. The unit may drop and cause personal injury if there is any damage.

6.1 Maintenance after Unit has been Shut Down for a Long Period

For example, in early summer or winter.

- Check and remove all objects that may clog the air inlets and outlets of the indoor and outdoor units.
- Clean the air filter and external shell of the unit. Please contact the installation or maintenance personnel. The installation/operation manual of the indoor unit includes maintenance tips and cleaning procedures. Make sure that the clean air filter is installed in its original position.
- Turn on the main power supply 12 hours before this unit is operated in order to ensure that the unit runs smoothly. The user interface is displayed once the power is turned on.

6.2 Maintenance Before Unit is Shut Down for a Long Period

For example, at the end of winter and summer.

- Run the indoor unit in the fan mode for about half a day to dry the internal parts of the unit.
- Turn off the power supply.

- Clean the air filter and external shell of the unit. Please contact the installation or maintenance personnel to clean the air filter and external shell of the indoor unit. The installation/operation manual of the specialized indoor unit includes maintenance tips and cleaning procedures. Make sure that the clean air filter is installed in its original position.

6.3 About the Refrigerant

This product contains fluorinated greenhouse gases as stipulated in the Kyoto Protocol. Do not discharge the gas into the atmosphere.

Refrigerant Type: R410A

GWP Value: 2088

Based on the applicable law, the refrigerant must be checked regularly for leakages. Please contact the installation personnel for more information.

WARNING

- The refrigerant in the air conditioner is relatively safer, and usually does not leak. If the refrigerant leaks, and comes in contact with burning objects in the room, it will produce harmful gases.
- Shut down any flammable heating device, ventilate the room and contact the agent of the unit immediately.
- Do not use the air conditioner again until the maintenance personnel has confirmed that the refrigerant leakage has been sufficiently resolved.

6.4 After-sales Service and Warranty

6.4.1 Warranty period

This product contains the warranty card that was completed by the agent during installation. The customer must check the completed warranty card and keep it properly.

If you need to repair the air conditioner during the warranty period, please contact the agent and provide the warranty card.

6.4.2 Recommended maintenance and inspection

As the use of the unit for many years will eventually lead to a dust layer, the performance of the unit will degenerate to a certain extent. As professional skills are needed to dismantle and clean the unit, and for the optimal maintenance effects of this unit, please contact your agent for more details.

When you request the agent for assistance, please remember to state:

- Complete model name of the air conditioner.
- Date of installation.
- Details on the fault symptoms or errors, and any defects.

WARNING

- Do not attempt to modify, dismantle, remove, reinstall or repair this unit, as the improper dismantling or installation may result in electric shock or fire. Please contact the agent.
- If the refrigerant accidentally leaks, make sure that there is no fire around the unit. The refrigerant itself is completely safe, non-toxic and non-flammable, but it will produce toxic gases when it accidentally leaks and comes in contact with flammable substances generated by existing heaters, and burning devices in the room. You must get a qualified maintenance personnel to verify that the point of leakage has been repaired or rectified before you restore the operations of the unit.

6.4.3 Shorter maintenance and replacement cycle

In the following situations, the "maintenance cycle" and "replacement cycle" may be shortened.

The unit is used in the following situations:

- Temperature and humidity fluctuations are outside the normal ranges.
- Large power fluctuations (voltage, frequency, waveform distortion etc.) (must not use the unit if the power fluctuations exceed the allowed range).
- Frequent collisions and vibrations.
- The air may contain dust, salt, harmful gas or oil such as sulphite and hydrogen sulphide.
- Frequent on and off of unit or operating time is too long (in places where the air conditioning is on for 24 hours a day).

7 TROUBLESHOOTING

The warranty does not cover the damage caused by dismantling or cleaning of the internal components by unauthorized agents.

WARNING

- When any unusual situations arises (burning odour, etc.), stop the unit immediately and turn off the power.
- As a result of a certain situation, the unit has caused damage, an electric shock, or a fire. Please contact the agent.

The system maintenance must be carried out by a qualified maintenance personnel:

Error	Measures
If a safety device, such as a fuse, circuit breaker or a leakage circuit breaker is triggered frequently or the ON/OFF switch is not working properly.	Turn off the main power switch.
The operating switch is not functioning normally.	Turn off the power supply.
If the unit number is displayed on the user interface, and the operating indicator is flickering, and an error code is shown on the screen as well.	Notify the installation personnel and report the error code.

Other than the above-mentioned situations, and where the fault is not obvious, if the system continues to malfunction, carry out the following steps to investigate.

Error	Measures
If the system does not run at all.	<p>Check if there is a power failure. Wait for the power supply to be restored. If a power failure occurs when the unit is still running, the system will restart automatically once the power is restored.</p> <p>Check if the fuse is broken or if the circuit breaker is working. If necessary, replace the fuse or reset the circuit breaker.</p>
If the system works fine in the fan-only operating mode but stop running once it enters the heating or cooling operation modes.	<p>Check if the air inlets or outlets of the outdoor or indoor units are blocked by any obstacles. Remove the obstacles, and maintain good ventilation in the room.</p>
The system is running but there is insufficient cooling or heating.	<p>Check if the air inlets or outlets of the outdoor or indoor units are blocked by any obstacles.</p> <p>Remove the obstacles, and maintain good ventilation in the room.</p> <p>Check if the filter is blocked (please refer to the "Maintenance" section in the manual of the indoor unit).</p> <p>Check the temperature settings.</p> <p>Check the fan speed settings on the user interface.</p> <p>Check if the doors and windows are open. Close the doors and windows to shut out wind from the external environment.</p> <p>Check if there are too many people in the room when the cooling mode is in operation. Check if the heat source of the room is too high.</p> <p>Check if there is direct sunlight into the room. Use curtains or blinds.</p> <p>Check that the angle of air flow is appropriate.</p>

7.1 Error Code: Overview

If an error code appears on the unit user, please contact the installation personnel and inform them of the error code, device model, and serial number (you can find the information on the nameplate of this unit).

Displayed Content	Error or protection definition	Remarks
E0	Communication error between outdoor units	Only displayed on the slave unit with the error
E2	Communication error between MS box and master unit	Only displayed on the the master unit
E4	T3/T4 temperature sensor error	Displayed on the unit with the error
E5	Abnormal power supply voltage	Displayed on the unit with the error
E7	Discharge temperature sensor error (T7C1)	Displayed on the unit with the error
E8	Outdoor unit address error	Displayed on the unit with the error
E9	EEPROM mismatch of compressor	Displayed on the unit with the error
F1	DC bus voltage error	Displayed on the unit with the error
F3	T6B temperature sensor error	Displayed on the unit with the error

Displayed Content	Error or protection definition	Remarks
F5	T6A temperature sensor error	Displayed on the unit with the error
zF6	Electronic expansion valve connection error	Displayed on the unit with the error
F9	T5 temperature sensor error	Displayed on the unit with the error
FA	T8 temperature sensor error	Displayed on the unit with the error
Fb	T9 temperature sensor error	Displayed on the unit with the error
Fc	TL temperature sensor error	Displayed on the unit with the error
Fd	T7 temperature sensor error	Displayed on the unit with the error
H0	Communication error between main board and compressor drive board	Displayed on the unit with the error
H2	Qty. of outdoor unit decreases error	Only displayed on the the master unit
H3	Qty. of outdoor unit increases error	Only displayed on the the master unit
H4	Compressor inverter module protection	Displayed on the unit with the error
H5	Low pressure protection lock out (P2 3X in 60 minutes)	Displayed on the unit with the error
H6	Compressor discharge temperature protection (P 4 3X in 100 minutes)	Displayed on the unit with the error
H7	Qty. of indoor units mismatching	Only displayed on the the master unit
H8	High pressure sensor error	Displayed on the unit with the error
xH9	DC fan module protection (P9 10X in 120 minutes)	Displayed on the unit with the error
Hb	Low pressure sensor error	Displayed on the unit with the error
yHd	Slave unit malfunction(y=1,2 , 1Hd stands for slave unit 1 error)	Only displayed on the the master unit
C7	Compressor inverter module temperature protection (PL 3X in 100 minutes)	Displayed on the unit with the error
P1	High pressure protection	Displayed on the unit with the error
P2	Low pressure protection	Displayed on the unit with the error
P31	Primary current protection	Displayed on the unit with the error
P32	Secondary current protection	Displayed on the unit with the error
P4	Discharge temperature protection or discharge temperature switch protection	Displayed on the unit with the error
U0	In the event of S10=ON, a forced test operation is set. However, a test operation is not performed for 30 minutes after power-on	Displayed on the unit with the error
xP9	DC fan module protection	Displayed on the unit with the error
PL	Compressor inverter module temperature protection	Displayed on the unit with the error
PP	Compressor discharge insufficient superheat protection	Displayed on the unit with the error
A0	Emergency stop	Displayed on the unit with the error
A1w	Refrigerant leakage protection	Displayed on the unit with the error
CA2	The system is connected to VRF DX AHU control box only	Displayed on the unit with the error
CA3	The system is connected only to the HT hydro module	Displayed on the unit with the error
CA4	The system is only connected to VRF DX AHU control box + HT hydro module	Displayed on the unit with the error
CA5	The system is simultaneously connected to VRF indoor + VRF DX AHU control box + HT hydro module	Displayed on the unit with the error
Cb1	VRF indoor is beyond the connection range	Displayed on the unit with the error
Cb2	VRF DX AHU control box is beyond the connection range	Displayed on the unit with the error
Cb3	The HT hydro module is beyond the connection range	Displayed on the unit with the error
Cb4	The Qty. of IDUs connected to the system is beyond the connection range	Displayed on the unit with the error
L0	Inverter compressor module error	
L1	DC bus low voltage protection	
L2	DC bus high voltage protection	
L3	Reserved	
L4	MCE error	
L5	Zero speed protection	
L6	Motor parameter error	
L7	Phase sequence error	
L8	Compressor frequency hopping error	
LA	PED software verification failed	

Note:

'x' is a placeholder for the fan address, with 1 representing fan A and 2 representing fan B.

'y' is a placeholder for the address (1 or 2) of the slave unit with the error.

'z' is a number for the electronic expansion valve, with 1 representing electronic expansion valve A and 3 representing electronic expansion valve C.

'w' is a placeholder for the protection mode of refrigerant leakage, with 1 representing the system should force to shutdown after the protection, 2 representing the system should force to shutdown after the protection in 12 hours and 3 representing the system should force to shutdown after the protection in 24 hours.

7.2 Fault Symptom: Non Air Conditioning Issues

The following fault symptoms are not caused by the air conditioning:

7.2.1 Fault symptom: System cannot run

Air conditioner does not start immediately after pressing the switch button on the controller. If the operating indicator lights up, the system is working normally. In order to prevent overloading of the compressor motor, restart the air conditioner 12 minutes after the switch button is pressed to prevent it from shutting down immediately after it is on. The same start-up delay occurs after the mode selector is pressed.

7.2.2 Fault symptom: Fan speed is not consistent with the setting

Even if the fan speed regulation button is pressed, the fan speed does not change. During heating, when the indoor temperature reaches the set temperature, the outdoor unit will shut down, and the indoor unit switches to the quiet fan speed mode. This is to prevent cold air from blowing directly at the room user. The fan speed will not change even when another indoor unit is in heating operation, if the button is pressed.

7.2.3 Fault symptom: Fan direction is not consistent with the setting

The air direction is not consistent with the user interface display. The air direction does not swing. This is because the unit is controlled by the centralized controller.

7.2.4 Fault symptom: White smoke from a certain unit (indoor unit)

During cooling when the humidity is high. If the interior pollution of the indoor unit is severe, the indoor temperature distribution will be uneven. Need to clean the interior of the indoor unit. Ask the agent for detailed information on how to clean the unit. This operation must be carried out by qualified maintenance personnel.

Surface immediately after cooling has stopped and when the indoor humidity is relatively low. This is due to the steam produced by the warm refrigerant gas on its return path to the indoor unit.

7.2.5 Fault symptom: White smoke from a certain unit (indoor unit, outdoor unit)

After the defrosting operation, switch the system to the heating mode. The moisture produced by the defrosting operation will become steam to be discharged out of the system.

7.2.6 Fault symptom: Noise from air conditioner (indoor unit)

A "zeen" sound is heard the moment the system is powered on. This noise is produced by the electronic expansion valves inside the indoor unit as they begin to work. The sound volume will be reduced in about 1 minute.

A soft and continuous "shah" sound can be heard when the system is in a cooling mode or has stopped running. This noise can be heard when the drainage pump is running (optional accessory).

A loud creaking "pishi-pishi" sound can be heard once the system stops after it has heated up the room. The expansion and contraction of plastic parts caused by temperature changes will also make this noise.

Once the indoor unit stops, a soft "sah" or "choro-choro" sound can be heard. This noise can be heard when another indoor unit is still running. Must maintain a small amount of refrigerant flow in order to prevent oil and refrigerant residues in the system.

7.2.7 Fault symptom: Noise from air conditioner (indoor unit, outdoor unit)

A soft, continuous hissing sound can be heard when the system is in cooling or defrosting operation. This is the sound of the refrigerant gas flowing in the indoor and outdoor units.

A hissing sound is heard the moment the system starts or stops operation or after the defrosting operation has been completed. This is the noise produced when the refrigerant flow is stopped or changed.

7.2.8 Fault symptom: Noise from air conditioner (outdoor unit)

When the tone of the operating noise changes. This noise is caused by frequency changes.

7.2.9 Fault symptom: Dust and dirt in the unit

When using the unit for the first time. This is because there is dust inside the unit.

7.2.10 Fault symptom: Strange odour from unit

This unit will absorb the odours of rooms, furniture, cigarettes and others, and then disperse the odours again.

Small animals stray into the unit, which can also cause odors.

7.2.11 Fault symptom: ODU fan does not run

In the course of operation. Control speed of fan motor to optimize the product operations.

7.2.12 Fault symptom: Hot air is felt when the indoor unit stops

IF different types of indoor units operating in the same system. When another unit is running, part of the refrigerant will still flow through this unit.

8 CHANGE INSTALLATION SITE

Please contact the agent to dismantle and reinstall all the units. You need specialized skills and technology to move the units.

9 DISPOSAL

This unit uses hydrogen fluorocarbons. Please contact the agent when you want to dispose this unit. Based on the requirements of the law, the collection, transportation and disposal of refrigerants must be in accordance with the regulations governing the collection and destruction of hydrofluorocarbons.

INFORMATION REQUIREMENTS (Technical fiche LOT 21)

Information requirements for air-to-air conditioners							
Model(s): MVD-V6R252W/V2GN1							
Test matching indoor units form, ducted: 4×MVD-56T1*							
Outdoor side heat exchanger of air conditioner: air							
Indoor side heat exchanger of air conditioner: air							
Type: compressor driven							
Driver of compressor: electric motor							
Item	Symbol	Value	Unit	Item	Symbol	Value	Unit
Rated cooling capacity	$P_{rated,c}$	22.4	kW	Seasonal space cooling energy efficiency	$\eta_{s,c}$	306	%
Declared cooling capacity for part load at given outdoor temperatures T_j and indoor 27/19°C (dry/wet bulb)				Declared energy efficiency ratio or gas utilisation efficiency /auxiliary energy factor for part load at given outdoor temperatures T_j			
$T_j=+35^\circ\text{C}$	P_{dc}	22.40	kW	$T_j=+35^\circ\text{C}$	EER_d	4.27	--
$T_j=+30^\circ\text{C}$	P_{dc}	16.51	kW	$T_j=+30^\circ\text{C}$	EER_d	5.45	--
$T_j=+25^\circ\text{C}$	P_{dc}	11.51	kW	$T_j=+25^\circ\text{C}$	EER_d	8.50	--
$T_j=+20^\circ\text{C}$	P_{dc}	6.69	kW	$T_j=+20^\circ\text{C}$	EER_d	17.16	--
Degradation co-efficient for air conditioners(*)	C_{dc}	0.25	--				
Power consumption in modes other than "active mode"							
Off mode	P_{OFF}	0.05	kW	Crankcase heater mode	P_{CK}	0.005	kW
Thermosat-off mode	P_{TO}	0.005	kW	Standby mode	P_{SB}	0.05	kW
Other items							
Capacity control	variable			For air-to-air air conditioner: air flow rate, outdoor measured	--	9000	m ³ /h
Sound power level, outdoor	L_{WA}	78	dB				
GWP of the refrigerant		2088	kg CO ₂ eq (100years)				
Contact details	SALVADOR ESCODA SA NAPOLES, 249 1st FLOOR 08013 BARCELONA (SPAIN) +34 93 446 27 80						
(*)If C_{dc} is not determined by measurement, then the default degradation coefficient of heat pumps shall be 0.25.							
Where information relates to multi-split air conditioners, the test result and performance data may be obtained on the basis of performance of the outdoor unit, with a combination of indoor unit(s) recommended by the manufacturer or importer.							

Heating - Information requirements for heat pumps

Information requirements for heat pumps								
Model(s): MVD-V6R252W/V2GN1								
Test matching indoor units form, ducted: 4×MVD-56T1*								
Outdoor side heat exchanger of air conditioner: air								
Indoor side heat exchanger of air conditioner: air								
If the heater is equipped with a supplementary heater: no								
Driver of compressor: electric motor								
Parameters shall be declared for the average heating season, parameters for the warmer and colder heating seasons are optional.								
Item	Symbol	Value	Unit		Item	Symbol	Value	Unit
Rated heating capacity	P _{rated,h}	22.4	kW		Seasonal space heating energy efficiency	η _{s,h}	164	%
Declared heating capacity for part load at indoor temperature 20°C and outdoor temperatures T _j					Declared coefficient of performance or gas utilisation efficiency/auxiliary energy factor for part load at given outdoor temperatures T _j			
T _j =-7°C	P _{dh}	12.12	kW		T _j =-7°C	COP _d	3.01	--
T _j =+2°C	P _{dh}	7.38	kW		T _j =+2°C	COP _d	3.94	--
T _j =+7°C	P _{dh}	5.91	kW		T _j =+7°C	COP _d	5.62	--
T _j =+12°C	P _{dh}	7.25	kW		T _j =+12°C	COP _d	7.23	--
T _{biv} =bivalent temperature	P _{dh}	13.70	kW		T _{biv} =bivalent temperature	COP _d	2.63	--
T _{OL} =operation temperature	P _{dh}	13.70	kW		T _{OL} =operation temperature	COP _d	2.63	--
Bivalent temperature	T _{biv}	-10	°C					
Degradation co-efficient for heat pumps(**)	C _{dh}	0.25	--					
Power consumption in modes other than "active mode"					Supplementary heater			
Off mode	P _{OFF}	0.05	kW		Back-up heating capacity(*)	elbu	0	kW
Thermosat-off mode	P _{TO}	0.05	kW		Type of energy input			
Crankcase heater mode	P _{CK}	0.005	kW		Standby mode	P _{SB}	0.05	kW
Other items								
Capacity control	variable				For air-to-air heat pump: air flow rate, outdoor measured	--	9000	m ³ /h
Sound power level,outdoor	LWA	78	dB					
GWP of the refrigerant		2088	kg CO ₂ eq (100years)					
Contact details	SALVADOR ESCODA SA NAPOLES, 249 1st FLOOR 08013 BARCELONA (SPAIN) +34 93 446 27 80							
(*)								
(**)If C _{dh} is not determined by measurement, then the default degradation coefficient of heat pumps shall be 0.25.								
Where information relates to multi-split heat pumps, xthe test result and performance data may be obtained on the basis of performance of the outdoor unit, with a combination of indoor unit(s) recommended by the manufacturer or importer.								

Cooling - Information requirements for air-to-air air conditioners

Information requirements for air-to-air conditioners							
Model(s): MVD-V6R280W/V2GN1							
Test matching indoor units form, ducted: 4×MVD-71T1*							
Outdoor side heat exchanger of air conditioner: air							
Indoor side heat exchanger of air conditioner: air							
Type: compressor driven							
Driver of compressor: electric motor							
Item	Symbol	Value	Unit	Item	Symbol	Value	Unit
Rated cooling capacity	P _{rated,c}	28.0	kW	Seasonal space cooling energy efficiency	η _{s,c}	299	%
Declared cooling capacity for part load at given outdoor temperatures T _j and indoor 27/19°C (dry/wet bulb)				Declared energy efficiency ratio or gas utilisation efficiency /auxiliary energy factor for part load at given outdoor temperatures T _j			
T _j =+35°C	P _{dc}	28.00	kW	T _j =+35°C	EER _d	3.90	--
T _j =+30°C	P _{dc}	20.63	kW	T _j =+30°C	EER _d	5.07	--
T _j =+25°C	P _{dc}	13.25	kW	T _j =+25°C	EER _d	8.37	--
T _j =+20°C	P _{dc}	6.69	kW	T _j =+20°C	EER _d	17.44	--
Degradation co-efficient for air conditioners(*)							
	C _{dc}	0.25	--				
Power consumption in modes other than "active mode"							
Off mode	P _{OFF}	0.05	kW	Crankcase heater mode	P _{CK}	0.005	kW
Thermosat-off mode	P _{TO}	0.005	kW	Standby mode	P _{SB}	0.05	kW
Other items							
Capacity control	variable			For air-to-air air conditioner: air flow rate, outdoor measured	--	9500	m ³ /h
Sound power level, outdoor	L _{WA}	78	dB				
GWP of the refrigerant		2088	kg CO ₂ eq (100years)				
Contact details	SALVADOR ESCODA SA NAPOLES, 249 1st FLOOR 08013 BARCELONA (SPAIN) +34 93 446 27 80						
(*)If C _{dc} is not determined by measurement, then the default degradation coefficient of heat pumps shall be 0.25.							
Where information relates to multi-split air conditioners, the test result and performance data may be obtained on the basis of performance of the outdoor unit, with a combination of indoor unit(s) recommended by the manufacturer or importer.							

Heating - Information requirements for heat pumps

Information requirements for heat pumps								
Model(s): MVD-V6R280W/V2GN1								
Test matching indoor units form, ducted: 4×MVD-71T1*								
Outdoor side heat exchanger of air conditioner: air								
Indoor side heat exchanger of air conditioner: air								
If the heater is equipped with a supplementary heater: no								
Driver of compressor: electric motor								
Parameters shall be declared for the average heating season, parameters for the warmer and colder heating seasons are optional.								
Item	Symbol	Value	Unit		Item	Symbol	Value	Unit
Rated heating capacity	P _{rated,h}	28.0	kW		Seasonal space heating energy efficiency	η _{s,h}	167	%
Declared heating capacity for part load at indoor temperature 20°C and outdoor temperatures T _j					Declared coefficient of performance or gas utilisation efficiency/auxiliary energy factor for part load at given outdoor temperatures T _j			
T _j =-7°C	P _{dh}	14.15	kW		T _j =-7°C	COP _d	2.83	--
T _j =+2°C	P _{dh}	8.62	kW		T _j =+2°C	COP _d	4.01	--
T _j =+7°C	P _{dh}	5.91	kW		T _j =+7°C	COP _d	5.76	--
T _j =+12°C	P _{dh}	7.25	kW		T _j =+12°C	COP _d	7.42	--
T _{biv} =bivalent temperature	P _{dh}	16.00	kW		T _{biv} =bivalent temperature	COP _d	2.49	--
T _{OL} =operation temperature	P _{dh}	16.00	kW		T _{OL} =operation temperature	COP _d	2.49	--
Bivalent temperature	T _{biv}	-10	°C					
Degradation co-efficient for heat pumps(**)	C _{dh}	0.25	--					
Power consumption in modes other than "active mode"					Supplementary heater			
Off mode	P _{OFF}	0.05	kW		Back-up heating capacity(*)	e _{lbu}	0	kW
Thermosat-off mode	P _{TO}	0.05	kW		Type of energy input			
Crankcase heater mode	P _{CK}	0.005	kW		Standby mode	P _{SB}	0.05	kW
Capacity control	variable				For air-to-air heat pump: air flow rate, outdoor measured	--	9500	m ³ /h
Sound power level, outdoor	L _{WA}	78	dB					
GWP of the refrigerant		2088	kg CO ₂ eq (100years)					
Contact details	SALVADOR ESCODA SA NAPOLES, 249 1st FLOOR 08013 BARCELONA (SPAIN) +34 93 446 27 80							
(*)								
(**)If C _{dh} is not determined by measurement, then the default degradation coefficient of heat pumps shall be 0.25.								
Where information relates to multi-split heat pumps, the test result and performance data may be obtained on the basis of performance of the outdoor unit, with a combination of indoor unit(s) recommended by the manufacturer or importer.								

Cooling - Information requirements for air-to-air air conditioners

Information requirements for air-to-air conditioners							
Model(s): MVD-V6R335W/V2GN1							
Test matching indoor units form, ducted: 6×MVD-56T1*							
Outdoor side heat exchanger of air conditioner: air							
Indoor side heat exchanger of air conditioner: air							
Type: compressor driven							
Driver of compressor: electric motor							
Item	Symbol	Value	Unit	Item	Symbol	Value	Unit
Rated cooling capacity	$P_{rated,c}$	33.5	kW	Seasonal space cooling energy efficiency	$\eta_{s,c}$	289	%
Declared cooling capacity for part load at given outdoor temperatures T_j and indoor 27/19°C (dry/wet bulb)				Declared energy efficiency ratio or gas utilisation efficiency /auxiliary energy factor for part load at given outdoor temperatures T_j			
$T_j=+35^\circ\text{C}$	P_{dc}	33.50	kW	$T_j=+35^\circ\text{C}$	EER_d	3.88	--
$T_j=+30^\circ\text{C}$	P_{dc}	24.68	kW	$T_j=+30^\circ\text{C}$	EER_d	5.29	--
$T_j=+25^\circ\text{C}$	P_{dc}	15.12	kW	$T_j=+25^\circ\text{C}$	EER_d	8.61	--
$T_j=+20^\circ\text{C}$	P_{dc}	8.72	kW	$T_j=+20^\circ\text{C}$	EER_d	12.49	--
Degradation co-efficient for air conditioners(*)	C_{dc}	0.25	--				
Power consumption in modes other than "active mode"							
Off mode	P_{OFF}	0.05	kW	Crankcase heater mode	P_{CK}	0.005	kW
Thermosat-off mode	P_{TO}	0.005	kW	Standby mode	P_{SB}	0.05	kW
Other items							
Capacity control	variable			For air-to-air air conditioner: air flow rate, outdoor measured	--	10000	m ³ /h
Sound power level, outdoor	L_{WA}	81	dB				
GWP of the refrigerant		2088	kg CO ₂ eq (100years)				
Contact details	SALVADOR ESCODA SA NAPOLES, 249 1st FLOOR 08013 BARCELONA (SPAIN) +34 93 446 27 80						
(*)If C_{dc} is not determined by measurement, then the default degradation coefficient of heat pumps shall be 0.25.							
Where information relates to multi-split air conditioners, the test result and performance data may be obtained on the basis of performance of the outdoor unit, with a combination of indoor unit(s) recommended by the manufacturer or importer.							

Heating - Information requirements for heat pumps

Information requirements for heat pumps								
Model(s): MVD-V6R335W/V2GN1								
Test matching indoor units form, ducted: 6×MVD-56T1*								
Outdoor side heat exchanger of air conditioner: air								
Indoor side heat exchanger of air conditioner: air								
If the heater is equipped with a supplementary heater: no								
Driver of compressor: electric motor								
Parameters shall be declared for the average heating season, parameters for the warmer and colder heating seasons are optional.								
Item	Symbol	Value	Unit		Item	Symbol	Value	Unit
Rated heating capacity	$P_{rated,h}$	33.5	kW		Seasonal space heating energy efficiency	$\eta_{s,h}$	181	%
Declared heating capacity for part load at indoor temperature 20°C and outdoor temperatures T_j					Declared coefficient of performance or gas utilisation efficiency/auxiliary energy factor for part load at given outdoor temperatures T_j			
$T_j=-7^\circ\text{C}$	P_{dh}	16.30	kW		$T_j=-7^\circ\text{C}$	COP_d	2.88	--
$T_j=+2^\circ\text{C}$	P_{dh}	9.92	kW		$T_j=+2^\circ\text{C}$	COP_d	4.38	--
$T_j=+7^\circ\text{C}$	P_{dh}	6.77	kW		$T_j=+7^\circ\text{C}$	COP_d	6.35	--
$T_j=+12^\circ\text{C}$	P_{dh}	6.12	kW		$T_j=+12^\circ\text{C}$	COP_d	8.12	--
T_{biv} =bivalent temperature	P_{dh}	18.43	kW		T_{biv} =bivalent temperature	COP_d	2.48	--
T_{OL} =operation temperature	P_{dh}	18.43	kW		T_{OL} =operation temperature	COP_d	2.48	--
Bivalent temperature	T_{biv}	-10	°C					
Degradation co-efficient for heat pumps(**)	C_{dh}	0.25	--					
Power consumption in modes other than "active mode"					Supplementary heater			
Off mode	P_{OFF}	0.05	kW		Back-up heating capacity(*)	e_{lbu}	0	kW
Thermosat-off mode	P_{TO}	0.05	kW		Type of energy input			
Crankcase heater mode	P_{CK}	0.005	kW		Standby mode	P_{SB}	0.05	kW
Other items								
Capacity control	variable				For air-to-air heat pump: air flow rate, outdoor measured	--	10000	m ³ /h
Sound power level, outdoor	LWA	81	dB					
GWP of the refrigerant		2088	kg CO ₂ eq (100years)					
Contact details	SALVADOR ESCODA SA NAPOLES, 249 1st FLOOR 08013 BARCELONA (SPAIN) +34 93 446 27 80							
(*)								
(**)If C_{dh} is not determined by measurement, then the default degradation coefficient of heat pumps shall be 0.25.								
Where information relates to multi-split heat pumps, the test result and performance data may be obtained on the basis of performance of the outdoor unit, with a combination of indoor unit(s) recommended by the manufacturer or importer.								

Cooling - Information requirements for air-to-air air conditioners

Information requirements for air-to-air conditioners							
Model(s): MVD-V6R400W/V2GN1							
Test matching indoor units form, ducted: 2×MVD-56T1*+4×MVD-71T1*							
Outdoor side heat exchanger of air conditioner: air							
Indoor side heat exchanger of air conditioner: air							
Type: compressor driven							
Driver of compressor: electric motor							
Item	Symbol	Value	Unit	Item	Symbol	Value	Unit
Rated cooling capacity	$P_{rated,c}$	40.0	kW	Seasonal space cooling energy efficiency	$\eta_{s,c}$	265	%
Declared cooling capacity for part load at given outdoor temperatures T_j and indoor 27/19°C (dry/wet bulb)				Declared energy efficiency ratio or gas utilisation efficiency /auxiliary energy factor for part load at given outdoor temperatures T_j			
$T_j=+35^\circ\text{C}$	P_{dc}	40.00	kW	$T_j=+35^\circ\text{C}$	EER_d	4.07	--
$T_j=+30^\circ\text{C}$	P_{dc}	29.47	kW	$T_j=+30^\circ\text{C}$	EER_d	4.84	--
$T_j=+25^\circ\text{C}$	P_{dc}	18.95	kW	$T_j=+25^\circ\text{C}$	EER_d	6.97	--
$T_j=+20^\circ\text{C}$	P_{dc}	12.60	kW	$T_j=+20^\circ\text{C}$	EER_d	13.68	--
Degradation co-efficient for air conditioners(*)	C_{dc}	0.25	--				
Power consumption in modes other than "active mode"							
Off mode	P_{OFF}	0.05	kW	Crankcase heater mode	P_{CK}	0.005	kW
Thermosat-off mode	P_{TO}	0.005	kW	Standby mode	P_{SB}	0.05	kW
Other items							
Capacity control	variable			For air-to-air air conditioner: air flow rate, outdoor measured	--	14000	m ³ /h
Sound power level, outdoor	L_{WA}	81	dB				
GWP of the refrigerant		2088	kg CO ₂ eq (100years)				
Contact details	SALVADOR ESCODA SA NAPOLES, 249 1st FLOOR 08013 BARCELONA (SPAIN) +34 93 446 27 80						
(*)If C_{dc} is not determined by measurement, then the default degradation coefficient of heat pumps shall be 0.25.							
Where information relates to multi-split air conditioners, the test result and performance data may be obtained on the basis of performance of the outdoor unit, with a combination of indoor unit(s) recommended by the manufacturer or importer.							

Heating - Information requirements for heat pumps

Information requirements for heat pumps								
Model(s): MVD-V6R400W/V2GN1								
Test matching indoor units form, ducted: 2×MVD-56T1*+4×MVD-71T1*								
Outdoor side heat exchanger of air conditioner: air								
Indoor side heat exchanger of air conditioner: air								
If the heater is equipped with a supplementary heater: no								
Driver of compressor: electric motor								
Parameters shall be declared for the average heating season, parameters for the warmer and colder heating seasons are optional.								
Item	Symbol	Value	Unit		Item	Symbol	Value	Unit
Rated heating capacity	P _{rated,h}	40.0	kW		Seasonal space heating energy efficiency	η _{s,h}	171	%
Declared heating capacity for part load at indoor temperature 20°C and outdoor temperatures T _j					Declared coefficient of performance or gas utilisation efficiency/auxiliary energy factor for part load at given outdoor temperatures T _j			
T _j =-7°C	P _{dh}	19.46	kW		T _j =-7°C	COP _d	3.00	--
T _j =+2°C	P _{dh}	11.85	kW		T _j =+2°C	COP _d	4.14	--
T _j =+7°C	P _{dh}	9.28	kW		T _j =+7°C	COP _d	5.84	--
T _j =+12°C	P _{dh}	8.76	kW		T _j =+12°C	COP _d	7.69	--
T _{biv} =bivalent temperature	P _{dh}	22.00	kW		T _{biv} =bivalent temperature	COP _d	2.42	--
T _{OL} =operation temperature	P _{dh}	22.00	kW		T _{OL} =operation temperature	COP _d	2.42	--
Bivalent temperature	T _{biv}	-10	°C					
Degradation co-efficient for heat pumps(**)	C _{dh}	0.25	--					
Power consumption in modes other than "active mode"					Supplementary heater			
Off mode	P _{OFF}	0.05	kW		Back-up heating capacity(*)	elbu	0	kW
Thermosat-off mode	P _{TO}	0.05	kW		Type of energy input			
Crankcase heater mode	P _{CK}	0.005	kW		Standby mode	P _{SB}	0.05	kW
Other items								
Capacity control	variable				For air-to-air heat pump: air flow rate, outdoor measured	--	14000	m ³ /h
Sound power level, outdoor	LWA	81	dB					
GWP of the refrigerant		2088	kg CO ₂ eq (100years)					
Contact details	SALVADOR ESCODA SA NAPOLES, 249 1st FLOOR 08013 BARCELONA (SPAIN) +34 93 446 27 80							
(*)								
(**)If C _{dh} is not determined by measurement, then the default degradation coefficient of heat pumps shall be 0.25.								
Where information relates to multi-split heat pumps, the test result and performance data may be obtained on the basis of performance of the outdoor unit, with a combination of indoor unit(s) recommended by the manufacturer or importer.								

Cooling - Information requirements for air-to-air air conditioners

Information requirements for air-to-air conditioners							
Model(s): MVD-V6R450W/V2GN1							
Test matching indoor units form, ducted: 4×MVD-71T1*+2×MVD-80T1*							
Outdoor side heat exchanger of air conditioner: air							
Indoor side heat exchanger of air conditioner: air							
Type: compressor driven							
Driver of compressor: electric motor							
Item	Symbol	Value	Unit	Item	Symbol	Value	Unit
Rated cooling capacity	$P_{rated,c}$	45.0	kW	Seasonal space cooling energy efficiency	$\eta_{s,c}$	264	%
Declared cooling capacity for part load at given outdoor temperatures T_j and indoor 27/19°C (dry/wet bulb)				Declared energy efficiency ratio or gas utilisation efficiency /auxiliary energy factor for part load at given outdoor temperatures T_j			
$T_j=+35^\circ\text{C}$	P_{dc}	45.00	kW	$T_j=+35^\circ\text{C}$	EER_d	3.75	--
$T_j=+30^\circ\text{C}$	P_{dc}	33.16	kW	$T_j=+30^\circ\text{C}$	EER_d	4.69	--
$T_j=+25^\circ\text{C}$	P_{dc}	21.32	kW	$T_j=+25^\circ\text{C}$	EER_d	7.11	--
$T_j=+20^\circ\text{C}$	P_{dc}	11.53	kW	$T_j=+20^\circ\text{C}$	EER_d	13.45	--
Degradation co-efficient for air conditioners(*)	C_{dc}	0.25	--				
Power consumption in modes other than "active mode"							
Off mode	P_{OFF}	0.05	kW	Crankcase heater mode	P_{CK}	0.005	kW
Thermosat-off mode	P_{TO}	0.005	kW	Standby mode	P_{SB}	0.05	kW
Other items							
Capacity control	variable			For air-to-air air conditioner: air flow rate, outdoor measured	--	14900	m ³ /h
Sound power level, outdoor	L_{WA}	88	dB				
GWP of the refrigerant		2088	kg CO ₂ eq (100years)				
Contact details	SALVADOR ESCODA SA NAPOLES, 249 1st FLOOR 08013 BARCELONA (SPAIN) +34 93 446 27 80						
(*)If C_{dc} is not determined by measurement, then the default degradation coefficient of heat pumps shall be 0.25.							
Where information relates to multi-split air conditioners, the test result and performance data may be obtained on the basis of performance of the outdoor uni, with a combination of indoor unit(s) recommended by the manufacturer or importer.							

Heating - Information requirements for heat pumps

Information requirements for heat pumps								
Model(s): MVD-V6R450W/V2GN1								
Test matching indoor units form, ducted 4×MVD-71T1*+2×MVD-80T1*								
Outdoor side heat exchanger of air conditioner: air								
Indoor side heat exchanger of air conditioner: air								
If the heater is equipped with a supplementary heater: no								
If applicable, driver of compressor: electric motor								
Parameters shall be declared for the average heating season, parameters for the warmer and colder heating seasons are optional.								
Item	Symbol	Value	Unit		Item	Symbol	Value	Unit
Rated heating capacity	P _{rated,h}	45.0	kW		Seasonal space heating energy efficiency	η _{s,h}	170	%
Declared heating capacity for part load at indoor temperature 20°C and outdoor temperatures T _j					Declared coefficient of performance or gas utilisation efficiency/auxiliary energy factor for part load at given outdoor temperatures T _j			
T _j =-7°C	P _{dh}	23.09	kW		T _j =-7°C	COP _d	2.58	--
T _j =+2°C	P _{dh}	14.05	kW		T _j =+2°C	COP _d	4.22	--
T _j =+7°C	P _{dh}	9.28	kW		T _j =+7°C	COP _d	5.88	--
T _j =+12°C	P _{dh}	8.76	kW		T _j =+12°C	COP _d	7.74	--
T _{biv} =bivalent temperature	P _{dh}	26.10	kW		T _{biv} =bivalent temperature	COP _d	2.24	--
T _{OL} =operation temperature	P _{dh}	26.10	kW		T _{OL} =operation temperature	COP _d	2.24	--
Bivalent temperature	T _{biv}	-10	°C					
Degradation co-efficient for heat pumps(**)	C _{dh}	0.25	--					
Power consumption in modes other than "active mode"					Supplementary heater			
Off mode	P _{OFF}	0.05	kW		Back-up heating capacity(*)	elbu	0	kW
Thermosat-off mode	P _{TO}	0.05	kW		Type of energy input			
Crankcase heater mode	P _{CK}	0.005	kW		Standby mode	P _{SB}	0.05	kW
Other items								
Capacity control	variable				For air-to-air heat pump: air flow rate, outdoor measured	--	14900	m ³ /h
Sound power level, outdoor	LWA	88	dB					
GWP of the refrigerant		2088	kg CO ₂ eq (100years)					
Contact details	SALVADOR ESCODA SA NAPOLES, 249 1st FLOOR 08013 BARCELONA (SPAIN) +34 93 446 27 80							
(*)								
(**)If C _{dh} is not determined by measurement, then the default degradation coefficient of heat pumps shall be 0.25.								
Where information relates to multi-split heat pumps, the test result and performance data may be obtained on the basis of performance of the outdoor unit, with a combination of indoor unit(s) recommended by the manufacturer or importer.								

Cooling - Information requirements for air-to-air air conditioners

Information requirements for air-to-air conditioners							
Model(s): MVD-V6R500W/V2GN1							
Test matching indoor units form, ducted: 4×MVD-56T1*+4×MVD-71T1*							
Outdoor side heat exchanger of air conditioner: air							
Indoor side heat exchanger of air conditioner: air							
Type: compressor driven							
Driver of compressor: electric motor							
Item	Symbol	Value	Unit	Item	Symbol	Value	Unit
Rated cooling capacity	$P_{rated,c}$	50.0	kW	Seasonal space cooling energy efficiency	$\eta_{s,c}$	272	%
Declared cooling capacity for part load at given outdoor temperatures T_j and indoor 27/19°C (dry/wet bulb)				Declared energy efficiency ratio or gas utilisation efficiency /auxiliary energy factor for part load at given outdoor temperatures T_j			
$T_j=+35^\circ\text{C}$	P_{dc}	50.00	kW	$T_j=+35^\circ\text{C}$	EER_d	3.62	--
$T_j=+30^\circ\text{C}$	P_{dc}	36.84	kW	$T_j=+30^\circ\text{C}$	EER_d	4.84	--
$T_j=+25^\circ\text{C}$	P_{dc}	23.68	kW	$T_j=+25^\circ\text{C}$	EER_d	7.06	--
$T_j=+20^\circ\text{C}$	P_{dc}	12.84	kW	$T_j=+20^\circ\text{C}$	EER_d	15.65	--
Degradation co-efficient for air conditioners(*)	C_{dc}	0.25	--				
Power consumption in modes other than "active mode"							
Off mode	P_{OFF}	0.05	kW	Crankcase heater mode	P_{CK}	0.005	kW
Thermosat-off mode	P_{TO}	0.005	kW	Standby mode	P_{SB}	0.05	kW
Other items							
Capacity control	variable			For air-to-air air conditioner: air flow rate, outdoor measured	--	15800	m ³ /h
Sound power level, outdoor	L_{WA}	88	dB				
GWP of the refrigerant		2088	kg CO ₂ eq (100years)				
Contact details	SALVADOR ESCODA SA NAPOLES, 249 1st FLOOR 08013 BARCELONA (SPAIN) +34 93 446 27 80						
(*)If C_{dc} is not determined by measurement, then the default degradation coefficient of heat pumps shall be 0.25.							
Where information relates to multi-split air conditioners, the test result and performance data may be obtained on the basis of performance of the outdoor unit, with a combination of indoor unit(s) recommended by the manufacturer or importer.							

Heating - Information requirements for heat pumps

Information requirements for heat pumps								
Model(s): MVD-V6R500W/V2GN1								
Test matching indoor units form, ducted: 4×MVD-56T1*+4×MVD-71T1*								
Outdoor side heat exchanger of air conditioner: air								
Indoor side heat exchanger of air conditioner: air								
If the heater is equipped with a supplementary heater: no								
Driver of compressor: electric motor								
Parameters shall be declared for the average heating season, parameters for the warmer and colder heating seasons are optional.								
Item	Symbol	Value	Unit		Item	Symbol	Value	Unit
Rated heating capacity	$P_{rated,h}$	50.0	kW		Seasonal space heating energy efficiency	$\eta_{s,h}$	165	%
Declared heating capacity for part load at indoor temperature 20°C and outdoor temperatures T_j					Declared coefficient of performance or gas utilisation efficiency/auxiliary energy factor for part load at given outdoor temperatures T_j			
$T_j=-7^\circ\text{C}$	P_{dh}	25.65	kW		$T_j=-7^\circ\text{C}$	COP_d	2.61	--
$T_j=+2^\circ\text{C}$	P_{dh}	15.62	kW		$T_j=+2^\circ\text{C}$	COP_d	4.01	--
$T_j=+7^\circ\text{C}$	P_{dh}	10.37	kW		$T_j=+7^\circ\text{C}$	COP_d	5.80	--
$T_j=+12^\circ\text{C}$	P_{dh}	9.03	kW		$T_j=+12^\circ\text{C}$	COP_d	7.45	--
T_{biv} =bivalent temperature	P_{dh}	29.00	kW		T_{biv} =bivalent temperature	COP_d	2.11	--
T_{OL} =operation temperature	P_{dh}	29.00	kW		T_{OL} =operation temperature	COP_d	2.11	--
Bivalent temperature	T_{biv}	-10	°C					
Degradation co-efficient for heat pumps(**)	C_{dh}	0.25	--					
Power consumption in modes other than "active mode"					Supplementary heater			
Off mode	P_{OFF}	0.05	kW		Back-up heating capacity(*)	el_{bu}	0	kW
Thermosat-off mode	P_{TO}	0.05	kW		Type of energy input			
Crankcase heater mode	P_{CK}	0.005	kW		Standby mode	P_{SB}	0.05	kW
Other items								
Capacity control	variable				For air-to-air heat pump: air flow rate, outdoor measured	--	15800	m ³ /h
Sound power level, outdoor	LWA	88	dB					
GWP of the refrigerant		2088	kg CO ₂ eq (100years)					
Contact details	SALVADOR ESCODA SA NAPOLES, 249 1st FLOOR 08013 BARCELONA (SPAIN) +34 93 446 27 80							
(*)								
(**)If C_{dh} is not determined by measurement, then the default degradation coefficient of heat pumps shall be 0.25.								
Where information relates to multi-split heat pumps, the test result and performance data may be obtained on the basis of performance of the outdoor unit, with a combination of indoor unit(s) recommended by the manufacturer or importer.								

Cooling - Information requirements for air-to-air air conditioners

Information requirements for air-to-air conditioners							
Model(s): MVD-V6R252W/V2GN1							
Test matching indoor units form2, cassette: 4×MVD-56Q4*							
Outdoor side heat exchanger of air conditioner: air							
Indoor side heat exchanger of air conditioner: air							
Type: compressor driven							
Driver of compressor: electric motor							
Item	Symbol	Value	Unit	Item	Symbol	Value	Unit
Rated cooling capacity	$P_{rated,c}$	22.4	kW	Seasonal space cooling energy efficiency	$\eta_{s,c}$	287	%
Declared cooling capacity for part load at given outdoor temperatures T_j and indoor 27/19°C (dry/wet bulb)				Declared energy efficiency ratio or gas utilisation efficiency /auxiliary energy factor for part load at given outdoor temperatures T_j			
$T_j=+35^\circ\text{C}$	P_{dc}	22.40	kW	$T_j=+35^\circ\text{C}$	EER_d	4.10	--
$T_j=+30^\circ\text{C}$	P_{dc}	16.51	kW	$T_j=+30^\circ\text{C}$	EER_d	5.87	--
$T_j=+25^\circ\text{C}$	P_{dc}	10.61	kW	$T_j=+25^\circ\text{C}$	EER_d	9.10	--
$T_j=+20^\circ\text{C}$	P_{dc}	9.56	kW	$T_j=+20^\circ\text{C}$	EER_d	10.47	--
Degradation co-efficient for air conditioners(*)	C_{dc}	0.25	--				
Power consumption in modes other than "active mode"							
Off mode	P_{OFF}	0.05	kW	Crankcase heater mode	P_{CK}	0.005	kW
Thermosat-off mode	P_{TO}	0.005	kW	Standby mode	P_{SB}	0.05	kW
Other items							
Capacity control	variable			For air-to-air air conditioner: air flow rate, outdoor measured	--	9000	m ³ /h
Sound power level, outdoor	L_{WA}	78	dB				
GWP of the refrigerant		2088	kg CO ₂ eq (100years)				
Contact details	SALVADOR ESCODA SA NAPOLES, 249 1st FLOOR 08013 BARCELONA (SPAIN) +34 93 446 27 80						
(*)If C_{dc} is not determined by measurement, then the default degradation coefficient of heat pumps shall be 0.25.							
Where information relates to multi-split air conditioners, the test result and performance data may be obtained on the basis of performance of the outdoor unit, with a combination of indoor unit(s) recommended by the manufacturer or importer.							

Heating - Information requirements for heat pumps

Information requirements for heat pumps								
Model(s): MVD-V6R252W/V2GN1								
Test matching indoor units form2, cassette: 4×MVD-56Q4*								
Outdoor side heat exchanger of air conditioner: air								
Indoor side heat exchanger of air conditioner: air								
If the heater is equipped with a supplementary heater: no								
Driver of compressor: electric motor								
Parameters shall be declared for the average heating season, parameters for the warmer and colder heating seasons are optional.								
Item	Symbol	Value	Unit		Item	Symbol	Value	Unit
Rated heating capacity	P _{rated,h}	22.4	kW		Seasonal space heating energy efficiency	η _{s,h}	165	%
Declared heating capacity for part load at indoor temperature 20°C and outdoor temperatures T _j					Declared coefficient of performance or gas utilisation efficiency/auxiliary energy factor for part load at given outdoor temperatures T _j			
T _j =-7°C	P _{dh}	12.12	kW		T _j =-7°C	COP _d	2.99	--
T _j =+2°C	P _{dh}	7.38	kW		T _j =+2°C	COP _d	3.98	--
T _j =+7°C	P _{dh}	5.84	kW		T _j =+7°C	COP _d	5.73	--
T _j =+12°C	P _{dh}	6.96	kW		T _j =+12°C	COP _d	6.92	--
T _{biv} =bivalent temperature	P _{dh}	13.70	kW		T _{biv} =bivalent temperature	COP _d	2.91	--
T _{OL} =operation temperature	P _{dh}	13.70	kW		T _{OL} =operation temperature	COP _d	2.91	--
Bivalent temperature	T _{biv}	-10	°C					
Degradation co-efficient for heat pumps(**)	C _{dh}	0.25	--					
Power consumption in modes other than "active mode"					Supplementary heater			
Off mode	P _{OFF}	0.05	kW		Back-up heating capacity(*)	elbu	0	kW
Thermosat-off mode	P _{TO}	0.05	kW		Type of energy input			
Crankcase heater mode	P _{CK}	0.005	kW		Standby mode	P _{SB}	0.05	kW
Other items								
Capacity control	variable				For air-to-air heat pump: air flow rate, outdoor measured	--	9000	m ³ /h
Sound power level, outdoor	LWA	78	dB					
GWP of the refrigerant		2088	kg CO ₂ eq (100years)					
Contact details	SALVADOR ESCODA SA NAPOLES, 249 1st FLOOR 08013 BARCELONA (SPAIN) +34 93 446 27 80							
(*)								
(**)If C _{dh} is not determined by measurement, then the default degradation coefficient of heat pumps shall be 0.25.								
Where information relates to multi-split heat pumps, the test result and performance data may be obtained on the basis of performance of the outdoor unit, with a combination of indoor unit(s) recommended by the manufacturer or importer.								

Cooling - Information requirements for air-to-air air conditioners

Information requirements for air-to-air conditioners							
Model(s): MVD-V6R280W/V2GN1							
Test matching indoor units form2, cassette: 4×MVD-71Q4*							
Outdoor side heat exchanger of air conditioner: air							
Indoor side heat exchanger of air conditioner: air							
Type: compressor driven							
Driver of compressor: electric motor							
Item	Symbol	Value	Unit	Item	Symbol	Value	Unit
Rated cooling capacity	$P_{rated,c}$	28.0	kW	Seasonal space cooling energy efficiency	$\eta_{s,c}$	265	%
Declared cooling capacity for part load at given outdoor temperatures T_j and indoor 27/19°C (dry/wet bulb)				Declared energy efficiency ratio or gas utilisation efficiency /auxiliary energy factor for part load at given outdoor temperatures T_j			
$T_j=+35^\circ\text{C}$	P_{dc}	28.00	kW	$T_j=+35^\circ\text{C}$	EER_d	3.60	--
$T_j=+30^\circ\text{C}$	P_{dc}	20.63	kW	$T_j=+30^\circ\text{C}$	EER_d	4.92	--
$T_j=+25^\circ\text{C}$	P_{dc}	13.26	kW	$T_j=+25^\circ\text{C}$	EER_d	7.63	--
$T_j=+20^\circ\text{C}$	P_{dc}	9.85	kW	$T_j=+20^\circ\text{C}$	EER_d	12.82	--
Degradation co-efficient for air conditioners(*)	C_{dc}	0.25	--				
Power consumption in modes other than "active mode"							
Off mode	P_{OFF}	0.05	kW	Crankcase heater mode	P_{CK}	0.005	kW
Thermosat-off mode	P_{TO}	0.005	kW	Standby mode	P_{SB}	0.05	kW
Other items							
Capacity control	variable			For air-to-air air conditioner: air flow rate, outdoor measured	--	9500	m ³ /h
Sound power level, outdoor	L_{WA}	78	dB				
GWP of the refrigerant		2088	kg CO ₂ eq (100years)				
Contact details	SALVADOR ESCODA SA NAPOLES, 249 1st FLOOR 08013 BARCELONA (SPAIN) +34 93 446 27 80						
(*)If C_{dc} is not determined by measurement, then the default degradation coefficient of heat pumps shall be 0.25.							
Where information relates to multi-split air conditioners, the test result and performance data may be obtained on the basis of performance of the outdoor unit, with a combination of indoor unit(s) recommended by the manufacturer or importer.							

Heating - Information requirements for heat pumps

Information requirements for heat pumps								
Model(s): MVD-V6R280W/V2GN1								
Test matching indoor units form2, cassette: 4×MVD-71Q4*								
Outdoor side heat exchanger of air conditioner: air								
Indoor side heat exchanger of air conditioner: air								
If the heater is equipped with a supplementary heater: no								
Driver of compressor: electric motor								
Parameters shall be declared for the average heating season, parameters for the warmer and colder heating seasons are optional.								
Item	Symbol	Value	Unit		Item	Symbol	Value	Unit
Rated heating capacity	$P_{rated,h}$	28.0	kW		Seasonal space heating energy efficiency	$\eta_{s,h}$	167	%
Declared heating capacity for part load at indoor temperature 20°C and outdoor temperatures T_j					Declared coefficient of performance or gas utilisation efficiency/auxiliary energy factor for part load at given outdoor temperatures T_j			
$T_j=-7^\circ\text{C}$	P_{dh}	14.15	kW		$T_j=-7^\circ\text{C}$	COP_d	2.76	--
$T_j=+2^\circ\text{C}$	P_{dh}	8.62	kW		$T_j=+2^\circ\text{C}$	COP_d	3.99	--
$T_j=+7^\circ\text{C}$	P_{dh}	5.84	kW		$T_j=+7^\circ\text{C}$	COP_d	5.96	--
$T_j=+12^\circ\text{C}$	P_{dh}	6.97	kW		$T_j=+12^\circ\text{C}$	COP_d	7.20	--
T_{biv} =bivalent temperature	P_{dh}	16.00	kW		T_{biv} =bivalent temperature	COP_d	2.70	--
T_{OL} =operation temperature	P_{dh}	16.00	kW		T_{OL} =operation temperature	COP_d	2.70	--
Bivalent temperature	T_{biv}	-10	°C					
Degradation co-efficient for heat pumps(**)	C_{dh}	0.25	--					
Power consumption in modes other than "active mode"					Supplementary heater			
Off mode	P_{OFF}	0.05	kW		Back-up heating capacity(*)	e_{lbu}	0	kW
Thermosat-off mode	P_{TO}	0.05	kW		Type of energy input			
Crankcase heater mode	P_{CK}	0.005	kW		Standby mode	P_{SB}	0.05	kW
Capacity control	variable				For air-to-air heat pump:air flow rate, outdoor measured	--	9500	m ³ /h
Sound power level, outdoor	LWA	78	dB					
GWP of the refrigerant		2088	kg CO ₂ eq (100years)					
Contact details	SALVADOR ESCODA SA NAPOLES, 249 1st FLOOR 08013 BARCELONA (SPAIN) +34 93 446 27 80							
(*)								
(**)If C_{dh} is not determined by measurement, then the default degradation coefficient of heat pumps shall be 0.25.								
Where information relates to multi-split heat pumps, the test result and performance data may be obtained on the basis of performance of the outdoor unit, with a combination of indoor unit(s) recommended by the manufacturer or importer.								

Cooling - Information requirements for air-to-air air conditioners

Information requirements for air-to-air conditioners							
Model(s): MVD-V6R335W/V2GN1							
Test matching indoor units form2, cassette: 6×MVD-56Q4*							
Outdoor side heat exchanger of air conditioner: air							
Indoor side heat exchanger of air conditioner: air							
Type: compressor driven							
Driver of compressor: electric motor							
Item	Symbol	Value	Unit	Item	Symbol	Value	Unit
Rated cooling capacity	$P_{rated,c}$	33.5	kW	Seasonal space cooling energy efficiency	$\eta_{s,c}$	258	%
Declared cooling capacity for part load at given outdoor temperatures T_j and indoor 27/19°C (dry/wet bulb)				Declared energy efficiency ratio or gas utilisation efficiency /auxiliary energy factor for part load at given outdoor temperatures T_j			
$T_j=+35^\circ\text{C}$	P_{dc}	33.50	kW	$T_j=+35^\circ\text{C}$	EER_d	3.50	--
$T_j=+30^\circ\text{C}$	P_{dc}	24.68	kW	$T_j=+30^\circ\text{C}$	EER_d	4.72	--
$T_j=+25^\circ\text{C}$	P_{dc}	15.87	kW	$T_j=+25^\circ\text{C}$	EER_d	6.83	--
$T_j=+20^\circ\text{C}$	P_{dc}	9.65	kW	$T_j=+20^\circ\text{C}$	EER_d	14.25	--
Degradation co-efficient for air conditioners(*)	C_{dc}	0.25	--				
Power consumption in modes other than "active mode"							
Off mode	P_{OFF}	0.05	kW	Crankcase heater mode	P_{CK}	0.005	kW
Thermosat-off mode	P_{TO}	0.005	kW	Standby mode	P_{SB}	0.05	kW
Other items							
Capacity control	variable			For air-to-air air conditioner: air flow rate, outdoor measured	--	10000	m ³ /h
Sound power level, outdoor	L_{WA}	81	dB				
GWP of the refrigerant		2088	kg CO ₂ eq (100years)				
Contact details	SALVADOR ESCODA SA NAPOLES, 249 1st FLOOR 08013 BARCELONA (SPAIN) +34 93 446 27 80						
(*)If C_{dc} is not determined by measurement, then the default degradation coefficient of heat pumps shall be 0.25.							
Where information relates to multi-split air conditioners, the test result and performance data may be obtained on the basis of performance of the outdoor unit, with a combination of indoor unit(s) recommended by the manufacturer or importer.							

Heating - Information requirements for heat pumps

Information requirements for heat pumps								
Model(s): MVD-V6R335W/V2GN1								
Test matching indoor units form2, cassette: 6×MVD-56Q4*								
Outdoor side heat exchanger of air conditioner: air								
Indoor side heat exchanger of air conditioner: air								
If the heater is equipped with a supplementary heater: no								
Driver of compressor: electric motor								
Parameters shall be declared for the average heating season, parameters for the warmer and colder heating seasons are optional.								
Item	Symbol	Value	Unit		Item	Symbol	Value	Unit
Rated heating capacity	$P_{rated,h}$	33.5	kW		Seasonal space heating energy efficiency	$\eta_{s,h}$	180	%
Declared heating capacity for part load at indoor temperature 20°C and outdoor temperatures T_j					Declared coefficient of performance or gas utilisation efficiency/auxiliary energy factor for part load at given outdoor temperatures T_j			
$T_j=-7^\circ\text{C}$	P_{dh}	16.30	kW		$T_j=-7^\circ\text{C}$	COP_d	2.82	--
$T_j=+2^\circ\text{C}$	P_{dh}	9.92	kW		$T_j=+2^\circ\text{C}$	COP_d	4.35	--
$T_j=+7^\circ\text{C}$	P_{dh}	6.64	kW		$T_j=+7^\circ\text{C}$	COP_d	6.41	--
$T_j=+12^\circ\text{C}$	P_{dh}	5.78	kW		$T_j=+12^\circ\text{C}$	COP_d	7.70	--
T_{biv} =bivalent temperature	P_{dh}	18.43	kW		T_{biv} =bivalent temperature	COP_d	2.66	--
T_{OL} =operation temperature	P_{dh}	18.43	kW		T_{OL} =operation temperature	COP_d	2.66	--
Bivalent temperature	T_{biv}	-10	°C					
Degradation co-efficient for heat pumps(**)	C_{dh}	0.25	--					
Power consumption in modes other than "active mode"					Supplementary heater			
Off mode	P_{OFF}	0.05	kW		Back-up heating capacity(*)	el_{bu}	0	kW
Thermosat-off mode	P_{TO}	0.05	kW		Type of energy input			
Crankcase heater mode	P_{CK}	0.005	kW		Standby mode	P_{SB}	0.05	kW
Other items								
Capacity control	variable				For air-to-air heat pump: air flow rate, outdoor measured	--	10000	m ³ /h
Sound power level, outdoor	LWA	81	dB					
GWP of the refrigerant		2088	kg CO ₂ eq (100years)					
Contact details	SALVADOR ESCODA SA NAPOLES, 249 1st FLOOR 08013 BARCELONA (SPAIN) +34 93 446 27 80							
(*)								
(**)If C_{dh} is not determined by measurement, then the default degradation coefficient of heat pumps shall be 0.25.								
Where information relates to multi-split heat pumps, the test result and performance data may be obtained on the basis of performance of the outdoor unit, with a combination of indoor unit(s) recommended by the manufacturer or importer.								

Cooling - Information requirements for air-to-air air conditioners

Information requirements for air-to-air conditioners							
Model(s): MVD-V6R400W/V2GN1							
Test matching indoor units form2, cassette: 2×MVD-56Q4*+4×MVD-71Q4*							
Outdoor side heat exchanger of air conditioner: air							
Indoor side heat exchanger of air conditioner: air							
Type: compressor driven							
Driver of compressor: electric motor							
Item	Symbol	Value	Unit	Item	Symbol	Value	Unit
Rated cooling capacity	$P_{rated,c}$	40.0	kW	Seasonal space cooling energy efficiency	$\eta_{s,c}$	265	%
Declared cooling capacity for part load at given outdoor temperatures T_j and indoor 27/19°C (dry/wet bulb)				Declared energy efficiency ratio or gas utilisation efficiency /auxiliary energy factor for part load at given outdoor temperatures T_j			
$T_j=+35^\circ\text{C}$	P_{dc}	40.00	kW	$T_j=+35^\circ\text{C}$	EER_d	3.45	--
$T_j=+30^\circ\text{C}$	P_{dc}	29.47	kW	$T_j=+30^\circ\text{C}$	EER_d	4.77	--
$T_j=+25^\circ\text{C}$	P_{dc}	18.95	kW	$T_j=+25^\circ\text{C}$	EER_d	7.17	--
$T_j=+20^\circ\text{C}$	P_{dc}	12.72	kW	$T_j=+20^\circ\text{C}$	EER_d	14.81	--
Degradation co-efficient for air conditioners(*)	C_{dc}	0.25	--				
Power consumption in modes other than "active mode"							
Off mode	P_{OFF}	0.05	kW	Crankcase heater mode	P_{CK}	0.005	kW
Thermosat-off mode	P_{TO}	0.005	kW	Standby mode	P_{SB}	0.05	kW
Other items							
Capacity control	variable			For air-to-air air conditioner: air flow rate, outdoor measured	--	14000	m ³ /h
Sound power level, outdoor	L_{WA}	81	dB				
GWP of the refrigerant		2088	kg CO ₂ eq (100years)				
Contact details	SALVADOR ESCODA SA NAPOLES, 249 1st FLOOR 08013 BARCELONA (SPAIN) +34 93 446 27 80						
(*)If C_{dc} is not determined by measurement, then the default degradation coefficient of heat pumps shall be 0.25.							
Where information relates to multi-split air conditioners, the test result and performance data may be obtained on the basis of performance of the outdoor unit, with a combination of indoor unit(s) recommended by the manufacturer or importer.							

Heating - Information requirements for heat pumps

Information requirements for heat pumps								
Model(s): MVD-V6R400W/V2GN1								
Test matching indoor units form2, cassette: 2×MVD-56Q4*+4×MVD-71Q4*								
Outdoor side heat exchanger of air conditioner: air								
Indoor side heat exchanger of air conditioner: air								
If the heater is equipped with a supplementary heater: no								
Driver of compressor: electric motor								
Parameters shall be declared for the average heating season, parameters for the warmer and colder heating seasons are optional.								
Item	Symbol	Value	Unit		Item	Symbol	Value	Unit
Rated heating capacity	$P_{rated,h}$	40.0	kW		Seasonal space heating energy efficiency	$\eta_{s,h}$	171	%
Declared heating capacity for part load at indoor temperature 20°C and outdoor temperatures T_j					Declared coefficient of performance or gas utilisation efficiency/auxiliary energy factor for part load at given outdoor temperatures T_j			
$T_j=-7^\circ\text{C}$	P_{dh}	19.46	kW		$T_j=-7^\circ\text{C}$	COP_d	3.02	--
$T_j=+2^\circ\text{C}$	P_{dh}	11.85	kW		$T_j=+2^\circ\text{C}$	COP_d	4.10	--
$T_j=+7^\circ\text{C}$	P_{dh}	9.14	kW		$T_j=+7^\circ\text{C}$	COP_d	5.95	--
$T_j=+12^\circ\text{C}$	P_{dh}	8.46	kW		$T_j=+12^\circ\text{C}$	COP_d	7.38	--
T_{biv} =bivalent temperature	P_{dh}	22.00	kW		T_{biv} =bivalent temperature	COP_d	2.67	--
T_{OL} =operation temperature	P_{dh}	22.00	kW		T_{OL} =operation temperature	COP_d	2.67	--
Bivalent temperature	T_{biv}	-10	°C					
Degradation co-efficient for heat pumps(**)	C_{dh}	0.25	--					
Power consumption in modes other than "active mode"					Supplementary heater			
Off mode	P_{OFF}	0.05	kW		Back-up heating capacity(*)	el_{bu}	0	kW
Thermosat-off mode	P_{TO}	0.05	kW		Type of energy input			
Crankcase heater mode	P_{CK}	0.005	kW		Standby mode	P_{SB}	0.05	kW
Other items								
Capacity control	variable				For air-to-air heat pump: air flow rate, outdoor measured	--	14000	m ³ /h
Sound power level, outdoor	LWA	81	dB					
GWP of the refrigerant		2088	kg CO ₂ eq (100years)					
Contact details	SALVADOR ESCODA SA NAPOLES, 249 1st FLOOR 08013 BARCELONA (SPAIN) +34 93 446 27 80							
(*)								
(**)If C_{dh} is not determined by measurement, then the default degradation coefficient of heat pumps shall be 0.25.								
Where information relates to multi-split heat pumps, the test result and performance data may be obtained on the basis of performance of the outdoor unit, with a combination of indoor unit(s) recommended by the manufacturer or importer.								

Cooling - Information requirements for air-to-air air conditioners

Information requirements for air-to-air conditioners								
Model(s): MVD-V6R450W/V2GN1								
Test matching indoor units form2, cassette: 4×MVD-71Q4*+2×MVD-80Q4*								
Outdoor side heat exchanger of air conditioner: air								
Indoor side heat exchanger of air conditioner: air								
Type: compressor driven								
Driver of compressor: electric motor								
Item	Symbol	Value	Unit		Item	Symbol	Value	Unit
Rated cooling capacity	$P_{rated,c}$	45.0	kW		Seasonal space cooling energy efficiency	$\eta_{s,c}$	245	%
Declared cooling capacity for part load at given outdoor temperatures T_j and indoor 27/19°C (dry/wet bulb)					Declared energy efficiency ratio or gas utilisation efficiency /auxiliary energy factor for part load at given outdoor temperatures T_j			
$T_j=+35^\circ\text{C}$	P_{dc}	45.00	kW		$T_j=+35^\circ\text{C}$	EER_d	3.20	--
$T_j=+30^\circ\text{C}$	P_{dc}	33.16	kW		$T_j=+30^\circ\text{C}$	EER_d	4.23	--
$T_j=+25^\circ\text{C}$	P_{dc}	21.32	kW		$T_j=+25^\circ\text{C}$	EER_d	6.68	--
$T_j=+20^\circ\text{C}$	P_{dc}	11.64	kW		$T_j=+20^\circ\text{C}$	EER_d	13.66	--
Degradation co-efficient for air conditioners(*)								
	C_{dc}	0.25	--					
Power consumption in modes other than "active mode"								
Off mode	P_{OFF}	0.05	kW		Crankcase heater mode	P_{CK}	0.005	kW
Thermosat-off mode	P_{TO}	0.005	kW		Standby mode	P_{SB}	0.05	kW
Other items								
Capacity control	variable				For air-to-air air conditioner: air flow rate, outdoor measured	--	14900	m ³ /h
Sound power level, outdoor	L_{WA}	88	dB					
GWP of the refrigerant		2088	kg CO ₂ eq (100years)					
Contact details	SALVADOR ESCODA SA NAPOLES, 249 1st FLOOR 08013 BARCELONA (SPAIN) +34 93 446 27 80							
(*)If C_{dc} is not determined by measurement, then the default degradation coefficient of heat pumps shall be 0.25.								
Where information relates to multi-split air conditioners, the test result and performance data may be obtained on the basis of performance of the outdoor unit, with a combination of indoor unit(s) recommended by the manufacturer or importer.								

Heating - Information requirements for heat pumps

Information requirements for heat pumps								
Model(s): MVD-V6R450W/V2GN1								
Test matching indoor units form2, cassette: 4×MVD-71Q4*+2×MVD-80Q4*								
Outdoor side heat exchanger of air conditioner: air								
Indoor side heat exchanger of air conditioner: air								
If the heater is equipped with a supplementary heater: no								
Driver of compressor: electric motor								
Parameters shall be declared for the average heating season, parameters for the warmer and colder heating seasons are optional.								
Item	Symbol	Value	Unit		Item	Symbol	Value	Unit
Rated heating capacity	P _{rated,h}	45.0	kW		Seasonal space heating energy efficiency	η _{s,h}	169	%
Declared heating capacity for part load at indoor temperature 20°C and outdoor temperatures T _j					Declared coefficient of performance or gas utilisation efficiency/auxiliary energy factor for part load at given outdoor temperatures T _j			
T _j =-7°C	P _{dh}	23.09	kW		T _j =-7°C	COP _d	2.56	--
T _j =+2°C	P _{dh}	14.05	kW		T _j =+2°C	COP _d	4.20	--
T _j =+7°C	P _{dh}	9.14	kW		T _j =+7°C	COP _d	5.87	--
T _j =+12°C	P _{dh}	8.46	kW		T _j =+12°C	COP _d	7.29	--
T _{biv} =bivalent temperature	P _{dh}	26.10	kW		T _{biv} =bivalent temperature	COP _d	2.36	--
T _{OL} =operation temperature	P _{dh}	26.10	kW		T _{OL} =operation temperature	COP _d	2.36	--
Bivalent temperature	T _{biv}	-10	°C					
Degradation co-efficient for heat pumps(**)								
	C _{dh}	0.25	--		Supplementary heater			
Power consumption in modes other than "active mode"					Supplementary heater			
Off mode	P _{OFF}	0.05	kW		Back-up heating capacity(*)	elbu	0	kW
Thermosat-off mode	P _{TO}	0.05	kW		Type of energy input			
Crankcase heater mode	P _{CK}	0.005	kW		Standby mode	P _{SB}	0.05	kW
Other items								
Capacity control	variable				For air-to-air heat pump: air flow rate, outdoor measured	--	14900	m ³ /h
Sound power level, outdoor	LWA	88	dB					
GWP of the refrigerant		2088	kg CO ₂ eq (100years)					
Contact details	SALVADOR ESCODA SA NAPOLES, 249 1st FLOOR 08013 BARCELONA (SPAIN) +34 93 446 27 80							
(*)								
(**)If C _{dh} is not determined by measurement, then the default degradation coefficient of heat pumps shall be 0.25.								
Where information relates to multi-split heat pumps, the test result and performance data may be obtained on the basis of performance of the outdoor unit, with a combination of indoor unit(s) recommended by the manufacturer or importer.								

Cooling - Information requirements for air-to-air air conditioners

Information requirements for air-to-air conditioners							
Model(s): MVD-V6R500W/V2GN1							
Test matching indoor units form2, cassette: 4×MVD-56Q4*+4×MVD-71Q4*							
Outdoor side heat exchanger of air conditioner: air							
Indoor side heat exchanger of air conditioner: air							
Type: compressor driven							
Driver of compressor: electric motor							
Item	Symbol	Value	Unit	Item	Symbol	Value	Unit
Rated cooling capacity	$P_{rated,c}$	50.0	kW	Seasonal space cooling energy efficiency	$\eta_{s,c}$	262	%
Declared cooling capacity for part load at given outdoor temperatures T_j and indoor 27/19°C (dry/wet bulb)				Declared energy efficiency ratio or gas utilisation efficiency /auxiliary energy factor for part load at given outdoor temperatures T_j			
$T_j=+35^\circ\text{C}$	P_{dc}	50.00	kW	$T_j=+35^\circ\text{C}$	EER_d	3.06	--
$T_j=+30^\circ\text{C}$	P_{dc}	36.84	kW	$T_j=+30^\circ\text{C}$	EER_d	4.60	--
$T_j=+25^\circ\text{C}$	P_{dc}	23.68	kW	$T_j=+25^\circ\text{C}$	EER_d	6.91	--
$T_j=+20^\circ\text{C}$	P_{dc}	12.98	kW	$T_j=+20^\circ\text{C}$	EER_d	16.40	--
Degradation co-efficient for air conditioners(*)	C_{dc}	0.25	--				
Power consumption in modes other than "active mode"							
Off mode	P_{OFF}	0.05	kW	Crankcase heater mode	P_{CK}	0.005	kW
Thermosat-off mode	P_{TO}	0.005	kW	Standby mode	P_{SB}	0.05	kW
Other items							
Capacity control	variable			For air-to-air air conditioner: air flow rate, outdoor measured	--	15800	m ³ /h
Sound power level, outdoor	L_{WA}	88	dB				
GWP of the refrigerant		2088	kg CO ₂ eq (100years)				
Contact details	SALVADOR ESCODA SA NAPOLES, 249 1st FLOOR 08013 BARCELONA (SPAIN) +34 93 446 27 80						
(*)If C_{dc} is not determined by measurement, then the default degradation coefficient of heat pumps shall be 0.25.							
Where information relates to multi-split air conditioners, the test result and performance data may be obtained on the basis of performance of the outdoor unit, with a combination of indoor unit(s) recommended by the manufacturer or importer.							

Heating - Information requirements for heat pumps

Information requirements for heat pumps								
Model(s): MVD-V6R500W/V2GN1								
Test matching indoor units form2, cassette: 4×MVD-56Q4*+4×MVD-71Q4*								
Outdoor side heat exchanger of air conditioner: air								
Indoor side heat exchanger of air conditioner: air								
If the heater is equipped with a supplementary heater: no								
Driver of compressor: electric motor								
Parameters shall be declared for the average heating season, parameters for the warmer and colder heating seasons are optional.								
Item	Symbol	Value	Unit		Item	Symbol	Value	Unit
Rated heating capacity	P _{rated,h}	50.0	kW		Seasonal space heating energy efficiency	η _{s,h}	169	%
Declared heating capacity for part load at indoor temperature 20°C and outdoor temperatures T _j					Declared coefficient of performance or gas utilisation efficiency/auxiliary energy factor for part load at given outdoor temperatures T _j			
T _j =-7°C	P _{dh}	25.65	kW		T _j =-7°C	COP _d	2.60	--
T _j =+2°C	P _{dh}	15.62	kW		T _j =+2°C	COP _d	4.16	--
T _j =+7°C	P _{dh}	10.11	kW		T _j =+7°C	COP _d	5.98	--
T _j =+12°C	P _{dh}	8.61	kW		T _j =+12°C	COP _d	7.13	--
T _{biv} =bivalent temperature	P _{dh}	29.00	kW		T _{biv} =bivalent temperature	COP _d	2.24	--
T _{OL} =operation temperature	P _{dh}	29.00	kW		T _{OL} =operation temperature	COP _d	2.24	--
Bivalent temperature	T _{biv}	-10	°C					
Degradation co-efficient for heat pumps(**)								
	C _{dh}	0.25	--		Supplementary heater			
Power consumption in modes other than "active mode"					Supplementary heater			
Off mode	P _{OFF}	0.05	kW		Back-up heating capacity(*)	elbu	0	kW
Thermosat-off mode	P _{TO}	0.05	kW		Type of energy input			
Crankcase heater mode	P _{CK}	0.005	kW		Standby mode	P _{SB}	0.05	kW
Other items								
Capacity control	variable				For air-to-air heat pump: air flow rate, outdoor measured	--	15800	m ³ /h
Sound power level, outdoor	LWA	88	dB					
GWP of the refrigerant		2088	kg CO ₂ eq (100years)					
Contact details	SALVADOR ESCODA SA NAPOLES, 249 1st FLOOR 08013 BARCELONA (SPAIN) +34 93 446 27 80							
(*)								
(**)If C _{dh} is not determined by measurement, then the default degradation coefficient of heat pumps shall be 0.25.								
Where information relates to multi-split heat pumps, the test result and performance data may be obtained on the basis of performance of the outdoor unit, with a combination of indoor unit(s) recommended by the manufacturer or importer.								

MUNDO  CLIMA[®]



www.mundoclima.com

C/ NÁPOLES 249 P1
08013 BARCELONA
ESPAÑA / SPAIN
(+34) 93 446 27 80
SAT: (+34) 93 652 53 57