

Ceiling Floor

Service manual



Ceiling & floor

1 Specifications	4
2 Dimensions	6
3 Unit Placement	7
4 Piping Diagram	8
5 Wiring Diagram	9
6 Capacity Tables.....	11
7 Electrical Characteristics.....	19
8 Sound Levels	20
9 Error codes.....	22

The 2nd Generation DC Series VRF Indoor Units

1 Specifications

Table 1.1: MVD-36(45,56,71)DLDN1 specifications

Model			MVD-36DLDN1	MVD-45DLDN1	MVD-56DLDN1	MVD-71DLDN1
Power supply			1 phase, 220-240V, 50Hz			
Cooling ¹	Capacity	kW	3.6	4.5	5.6	7.1
		kBtu/h	12.3	15.4	19.1	24.2
	Power input	W	49	115	115	115
Heating ²	Capacity	kW	4.0	5.0	6.3	8.0
		kBtu/h	13.6	17.1	21.5	27.3
	Power input	W	49	115	115	115
Fan motor	Model		WZDK100-38GS-2			
	Type		DC			
	Brand		Panasonic/Match-Well			
	Speed ³	r/min	770/740/700/680/650/630/610	1380/1330/1300/1260/1210/1140/1070	1380/1340/1300/1260/1190/1140/1120	
Indoor coil	Number of rows		2	3	3	3
	Tube pitch × row pitch	mm	25.4×22			
	Fin spacing	mm	1.8			
	Fin type		Hydrophilic aluminum			
	Tube OD and type	mm	Φ9.53 Inner-groove			
	Dimensions (L×H×W)	mm	804×254×44	804×254×66		
	Number of circuits		3			
Air flow rate ³		m ³ /h	550/525/500/480/460/440/420	930/895/860/830/792/755/720		
Sound pressure level ⁴		dB(A)	40/39/38/38/37/36/36	43/42/41/41/39/38/38		
Sound power level		dB(A)	53/52/51/51/50/49/49	56/55/54/54/52/51/51		
Unit	Net dimensions ⁵ (W×H×D)		990×660×203			
	Packed dimensions (W×H×D)		1089×744×296			
	Net/Gross weight		27/33	28/34		
Refrigerant type			R410A			
Throttle	Type		Electronic expansion valve			
	Model		D20MISZ-1R(L)			
Design pressure (H/L)		MPa	4.4/2.6			
Pipe connections	Liquid/Gas pipe		Φ6.35/Φ12.7		Φ9.53/Φ15.9	
	Drain pipe		OD Φ16			

Notes:

- Indoor temperature 27°C DB, 19°C WB; outdoor temperature 35°C DB; equivalent refrigerant piping length 7.5m with zero level difference.
- Indoor temperature 20°C DB; outdoor temperature 7°C DB, 6°C WB; equivalent refrigerant piping length 7.5m with zero level difference.
- Fan motor speed and air flow rate are from the highest speed to the lowest speed, total 7 rates for each model.
- Sound pressure level is from highest level to lowest level, total 7 levels for each model. Sound pressure level is measured in a semi-anechoic chamber.
- Unit body dimensions given are the largest external dimensions of the unit, including hanger attachments.

The 2nd Generation DC Series VRF Indoor Units

Table 1.2: MVD-80(90,112,140)DLDN1 specifications

Model			MVD-80DLDN1	MVD-90DLDN1	MVD-112DLDN1	MVD-140DLDN1
Power supply			1 phase, 220-240V, 50Hz			
Cooling ¹	Capacity	kW	8.0	9.0	11.2	14.0
		kBtu/h	27.2	30.7	38.2	47.8
	Power input	W	130	130	180	180
Heating ²	Capacity	kW	9.0	10.0	12.5	15.0
		kBtu/h	30.7	34.1	42.7	51.2
	Power input	W	130	130	180	180
Fan motor	Model		WZDK100-38GS-1		WZDK100-38GS-2	
	Type		DC		DC	
	Brand		Panasonic/Match-Well			
	Speed ³	r/min	1300/1270/1230/1200/1160/1120/1090		1140/1090/1060/1040/1010/990/970	
Indoor coil	Number of rows		3			
	Tube pitch × row pitch	mm	25.4×22			
	Fin spacing	mm	1.8			
	Fin type		Hydrophilic aluminum			
	Tube OD and type	mm	Φ9.52 Inner-groove			
	Dimensions (L×H×W)	mm	1094×254×66		1360×254×66	
	Number of circuits		5			
Air flow rate ³		m ³ /h	1280/1245/1210/1170/1130/1085/1050		1890/1830/1765/1700/1660/1620/1580	
Sound pressure level ⁴		dB(A)	45/44/43/43/42/41/40		47/46/45/45/44/43/42	
Sound power level		dB(A)	58/57/56/56/55/54/53		60/59/58/58/57/56/55	
Unit	Net dimensions ⁵ (W×H×D)	mm	1280×660×203		1670×680×244	
	Packed dimensions (W×H×D)	mm	1379×744×296		1915×760×330	
	Net/Gross weight	kg	35/41		48/58	
Refrigerant type			R410A			
Throttle	Type	Electronic expansion valve				
	Model	BD24FKS(L)				
Design pressure (H/L)		MPa	4.4/2.6			
Pipe connections	Liquid/Gas pipe	mm	Φ9.53/Φ15.9			
	Drain pipe	mm	OD Φ16			

Notes:

1. Indoor temperature 27°C DB, 19°C WB; outdoor temperature 35°C DB; equivalent refrigerant piping length 7.5m with zero level difference.
2. Indoor temperature 20°C DB; outdoor temperature 7°C DB, 6°C WB; equivalent refrigerant piping length 7.5m with zero level difference.
3. Fan motor speed and air flow rate are from the highest speed to the lowest speed, total 7 rates for each model.
4. Sound pressure level is from highest level to lowest level, total 7 levels for each model. Sound pressure level is measured in a semi-anechoic chamber.
5. Unit body dimensions given are the largest external dimensions of the unit, including hanger attachments.

The 2nd Generation DC Series VRF Indoor Units

2 Dimensions

2.1 Unit Dimensions

Figure 2.1: Ceiling & floor dimensions (unit: mm)

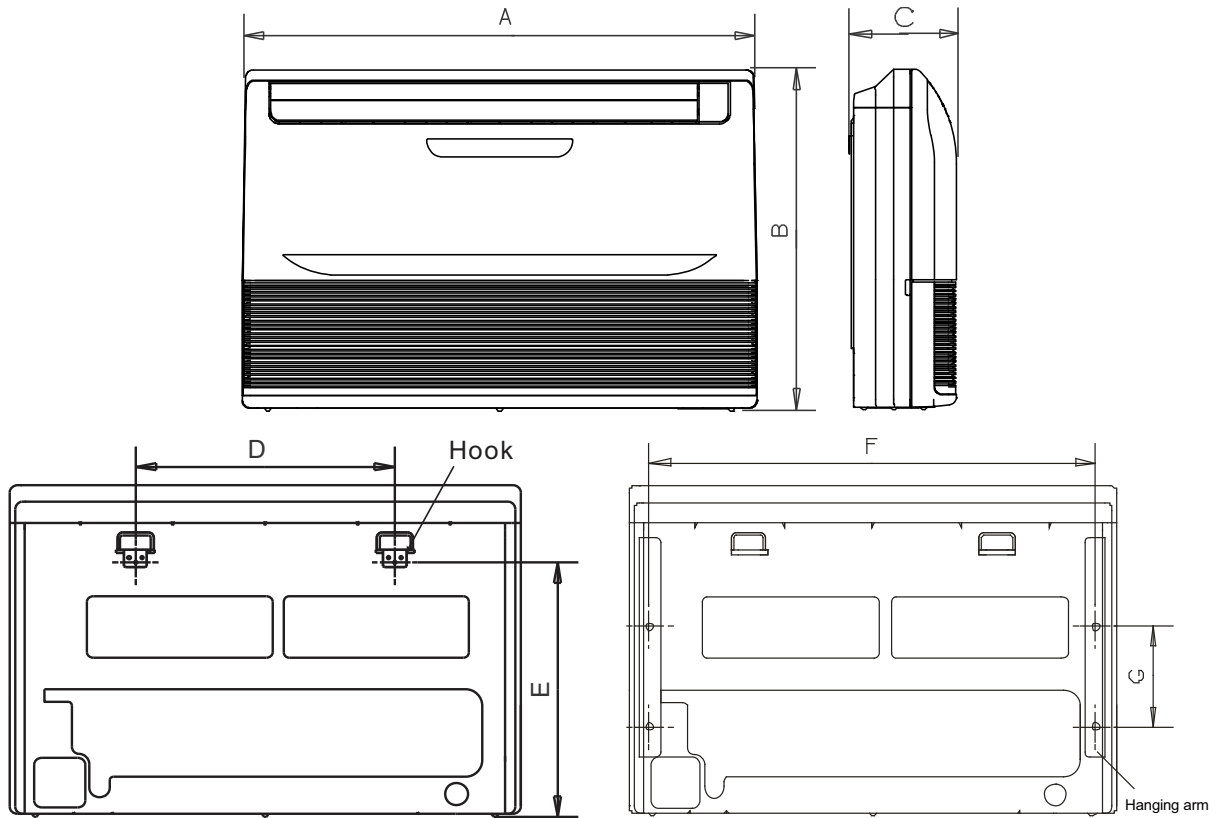

Table 2.1: Ceiling & floor dimensions

Model	Dimensions (mm)						
	A	B	C	D	E	F	G
MVD-36DLDN1 MVD-45DLDN1 MVD-71DLDN1	990	660	203	505	506	907	200
MVD-80DLDN1 MVD-90DLDN1	1280	660	203	795	506	1195	200
MVD-112DLDN1 MVD-140DLDN1	1670	680	244	1070	450	1542	200

Table 2.2: Ceiling & floor piping connections

Model	Gas pipe (mm)	Liquid pipe (mm)
MVD-36DLDN1 MVD-45DLDN1	Φ12.7	Φ6.35
MVD-71DLDN1 MVD-80DLDN1 MVD-90DLDN1 MVD-112DLDN1 MVD-140DLDN1	Φ15.9	Φ9.53

3 Unit Placement

3.1 Placement Considerations

Unit placement should take account of the following considerations:

- Units should not be installed in the following locations:
 - Where exposure to direct radiation from a high-temperature heat source or to interference from a source of electromagnetic radiation may occur.
 - Where dust or dirt may affect heat exchangers.
 - Where exposure to oil or to corrosive or harmful gases, such as acidic or alkaline gases, may occur.
 - Where exposure to salinity may occur, such as seaside locations.
 - Where highly flammable materials are present.
 - Where exposure to oily air may occur, such as a kitchen.
 - Where exposure to very high humidity may occur, such as a laundry.
- Units should be installed in positions where:
 - The ceiling is horizontal and is able to bear the unit's weight.
 - There are no obstructions that could impede the airflow into and out of the unit.
 - The airflow out of the unit can reach throughout the room.
 - There is sufficient space for access during installation, servicing and maintenance.
 - The refrigerant piping and drain piping can be easily connected to the refrigerant piping and drain piping systems.
 - Short-circuit ventilation (where outlet air returns quickly to a unit's air inlet) will not occur.

3.2 Space Requirements

Figure 3.1: Ceiling & floor space requirements (unit: mm)

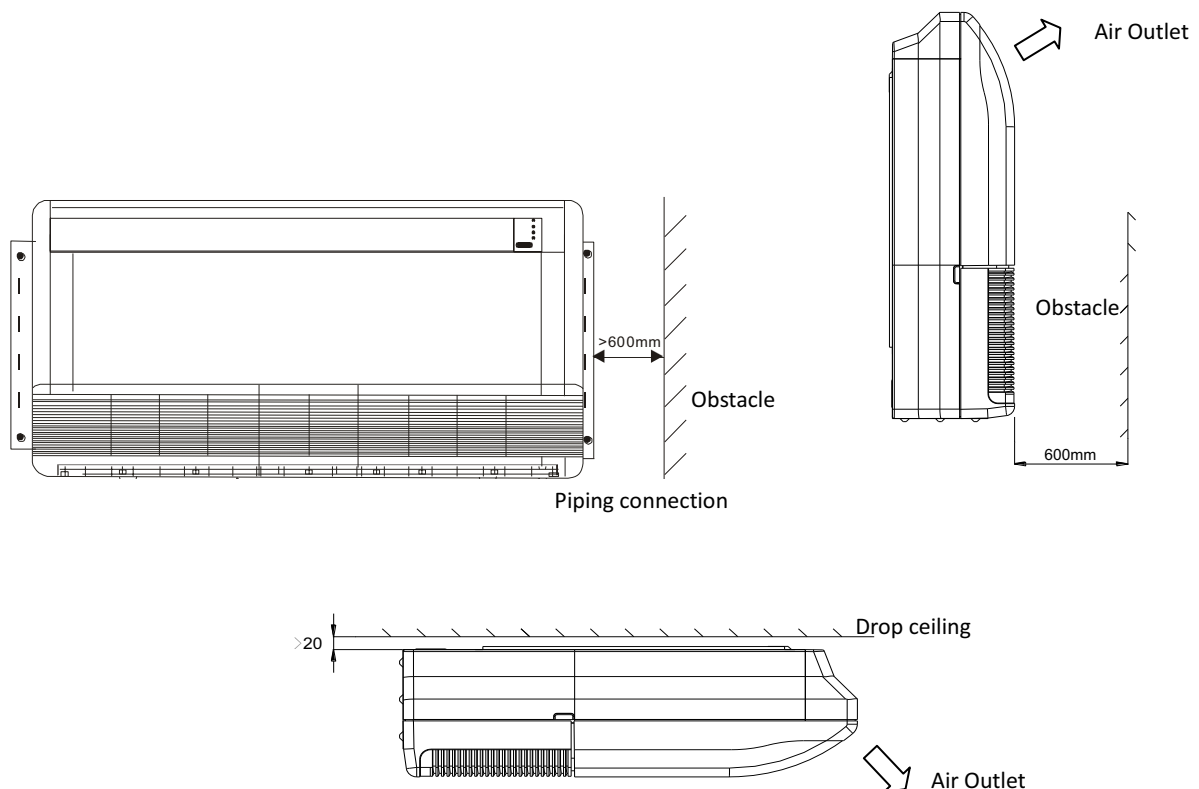

The 2nd Generation DC Series VRF Indoor Units

4 Piping Diagram

Figure 4.1: Ceiling & floor piping diagram

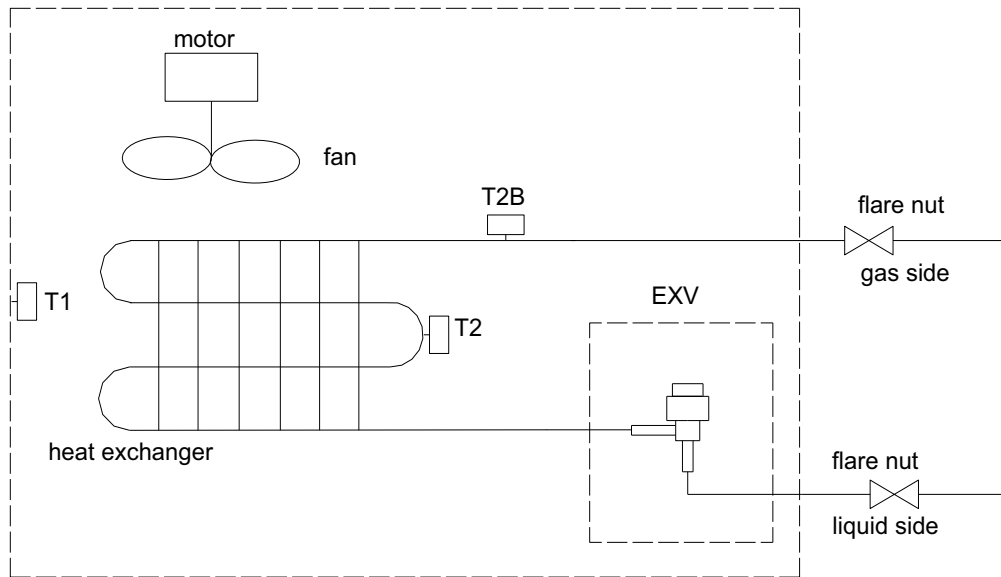

Legend	
T1	Indoor ambient temperature sensor
T2	Indoor heat exchanger mid-point temperature sensor
T2B	Indoor heat exchanger outlet temperature sensor

5 Wiring Diagram

Figure 5.1: Ceiling & floor wiring diagram

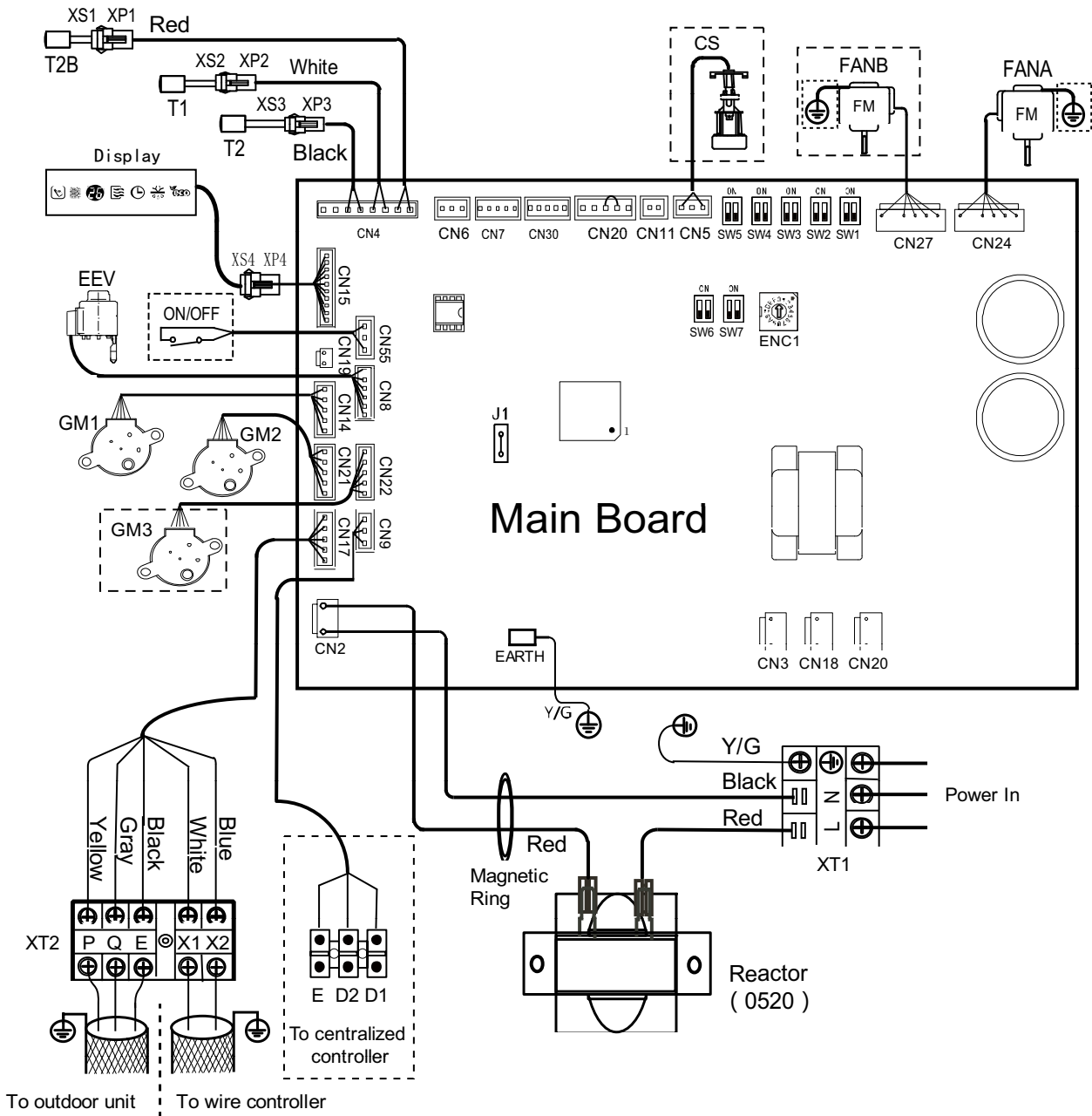

Code	Title
FM	Indoor fan motor
PUMP	Pump motor
T1	Room temp. sensor
T2B	Outlet pipe temp. sensor
T2	Middle pipe temp. sensor
EEV	Electronic expansion valve
XT1-2	Terminal
GM1-3	Swing motor
CS	Water level switch
XP1-5 XS1-5	Connectors

ENC1	Toggle Switch	Set horsepower
	Code	Capacity
	0	2200W
	1	2800W
	2	3600W
	3	4500W
	4	5600W
	5	7100W
	6	8000W
	7	9000W
	8	10000W
	9	11200W
	A	12500W
B	14000W	

Notes for installers and service engineers

Caution

- All installation, servicing and maintenance must be carried out by competent and suitably qualified, certified and accredited professionals and in accordance with all applicable legislation.
- Units should be grounded in accordance with all applicable legislation. Metal and other conductive components should be insulated in accordance with all applicable legislation.
- Power supply wiring should be securely fastened at the power supply terminals – loose power supply wiring would represent a fire risk.
- After installation, servicing or maintenance, the electric control box cover should be closed. Failing to close the electric control box cover risks fire or electric shock.
- Switch ENC1 (indoor unit capacity setting) is factory-set and its setting should normally not be changed. The only circumstances in which a switch ENC1 might need to be set in the field is when replacing a main PCB. When replacing a main PCB, ensure that the capacity setting on switch ENC1 on the new PCB is consistent with the unit capacity given on the unit's nameplate.

The 2nd Generation DC Series VRF Indoor Units

6 Capacity Tables

6.1 Cooling Capacity Table

Table 6.1: Ceiling & floor cooling capacity

Capacity (kW)	Outdoor air temperature (°C DB)	Indoor air temperature (°C WB/DB)													
		14/20		16/23		18/26		19/27		20/28		22/30		24/32	
		TC	SC	TC	SC	TC	SC	TC	SC	TC	SC	TC	SC	TC	SC
		kW	kW	kW	kW	kW	kW	kW	kW	kW	kW	kW	kW	kW	kW
3.6	10.0	2.5	1.9	2.9	2.1	3.4	2.3	3.6	2.4	3.8	2.5	4.3	2.4	4.7	2.5
	12.0	2.5	1.9	2.9	2.1	3.4	2.3	3.6	2.4	3.8	2.5	4.3	2.4	4.7	2.5
	14.0	2.5	1.9	2.9	2.1	3.4	2.3	3.6	2.4	3.8	2.5	4.3	2.4	4.6	2.4
	16.0	2.5	1.9	2.9	2.1	3.4	2.3	3.6	2.4	3.8	2.5	4.3	2.4	4.5	2.4
	18.0	2.5	1.9	2.9	2.1	3.4	2.3	3.6	2.4	3.8	2.5	4.3	2.4	4.5	2.4
	20.0	2.5	1.9	2.9	2.1	3.4	2.3	3.6	2.4	3.8	2.5	4.3	2.4	4.4	2.3
	21.0	2.5	1.9	2.9	2.1	3.4	2.3	3.6	2.4	3.8	2.5	4.3	2.4	4.4	2.3
	23.0	2.5	1.9	2.9	2.1	3.4	2.3	3.6	2.4	3.8	2.5	4.1	2.3	4.3	2.2
	25.0	2.5	1.9	2.9	2.1	3.4	2.3	3.6	2.4	3.8	2.5	4.1	2.3	4.2	2.2
	27.0	2.5	1.9	2.9	2.1	3.4	2.3	3.6	2.4	3.8	2.5	4.0	2.2	4.2	2.2
	29.0	2.5	1.9	2.9	2.1	3.4	2.3	3.6	2.4	3.8	2.5	4.0	2.2	4.1	2.2
	31.0	2.5	1.9	2.9	2.1	3.4	2.3	3.6	2.4	3.8	2.5	4.2	2.6	4.1	2.2
	33.0	2.5	1.9	2.9	2.1	3.4	2.3	3.6	2.4	3.8	2.5	4.2	2.6	3.9	2.1
	35.0	2.5	1.9	2.9	2.1	3.4	2.3	3.6	2.4	3.8	2.5	4.2	2.6	3.9	2.1
	37.0	2.5	1.9	2.9	2.1	3.4	2.3	3.6	2.4	3.7	2.4	3.8	2.3	3.9	2.1
	39.0	2.5	1.9	2.9	2.1	3.4	2.3	3.6	2.4	3.7	2.4	3.8	2.3	3.8	2.1
42.0	2.5	1.9	2.9	2.1	3.4	2.3	3.6	2.4	3.7	2.4	3.8	2.3	3.8	2.1	
44.0	2.5	1.9	2.9	2.1	3.4	2.3	3.6	2.4	3.7	2.4	3.8	2.3	3.8	2.1	
46.0	2.5	1.9	2.9	2.1	3.4	2.3	3.6	2.4	3.7	2.4	3.8	2.3	3.8	2.1	
4.5	10.0	3.1	2.4	3.7	2.6	4.2	2.8	4.5	2.9	4.8	3.0	5.3	3.4	5.9	3.0
	12.0	3.1	2.4	3.7	2.6	4.2	2.8	4.5	2.9	4.8	3.0	5.3	3.4	5.9	3.0
	14.0	3.1	2.4	3.7	2.6	4.2	2.8	4.5	2.9	4.8	3.0	5.3	3.4	5.8	3.0
	16.0	3.1	2.4	3.7	2.6	4.2	2.8	4.5	2.9	4.8	3.0	5.3	3.4	5.6	2.9
	18.0	3.1	2.4	3.7	2.6	4.2	2.8	4.5	2.9	4.8	3.0	5.3	3.4	5.7	3.0
	20.0	3.1	2.4	3.7	2.6	4.2	2.8	4.5	2.9	4.8	3.0	5.3	3.4	5.7	3.0
	21.0	3.1	2.4	3.7	2.6	4.2	2.8	4.5	2.9	4.8	3.0	5.3	3.4	5.6	3.0
	23.0	3.1	2.4	3.7	2.6	4.2	2.8	4.5	2.9	4.8	3.0	5.3	3.4	5.5	3.0
	25.0	3.1	2.4	3.7	2.6	4.2	2.8	4.5	2.9	4.8	3.0	5.2	3.0	5.4	2.9
	27.0	3.1	2.4	3.7	2.6	4.2	2.8	4.5	2.9	4.8	3.0	5.1	3.0	5.2	2.8
	29.0	3.1	2.4	3.7	2.6	4.2	2.8	4.5	2.9	4.8	3.0	5.1	2.9	5.2	2.8
	31.0	3.1	2.4	3.7	2.6	4.2	2.8	4.5	2.9	4.8	3.0	5.0	2.9	5.1	2.7
	33.0	3.1	2.4	3.7	2.6	4.2	2.8	4.5	2.9	4.8	3.0	4.9	2.8	5.1	2.7
	35.0	3.1	2.4	3.7	2.6	4.2	2.8	4.5	2.9	4.8	3.0	4.8	2.8	5.0	2.7
	37.0	3.1	2.4	3.7	2.6	4.2	2.8	4.5	2.9	4.8	3.0	4.8	2.9	4.9	2.6
	39.0	3.1	2.4	3.7	2.6	4.2	2.8	4.5	2.9	4.6	2.8	4.7	2.8	4.8	2.6
42.0	3.1	2.4	3.7	2.6	4.2	2.8	4.5	2.9	4.6	2.8	4.7	2.8	4.8	2.6	
44.0	3.1	2.4	3.7	2.6	4.2	2.8	4.5	2.9	4.6	2.8	4.7	2.8	4.8	2.6	
46.0	3.1	2.4	3.7	2.6	4.2	2.8	4.5	2.9	4.6	2.8	4.7	3.1	4.8	2.6	

Abbreviations:

TC: Total capacity

SC: Sensible capacity

Notes:

1. Shaded cells indicate rating condition.

Table continued on next page ...

The 2nd Generation DC Series VRF Indoor Units

Table 6.1: Ceiling & floor cooling capacity (continued)

Capacity (kW)	Outdoor air temperature (°C DB)	Indoor air temperature (°C WB/DB)													
		14/20		16/23		18/26		19/27		20/28		22/30		24/32	
		TC	SC	TC	SC	TC	SC	TC	SC	TC	SC	TC	SC	TC	SC
		kW	kW	kW	kW	kW	kW	kW	kW	kW	kW	kW	kW	kW	kW
5.6	10.0	3.9	2.7	4.6	3.0	5.3	3.3	5.6	3.4	5.9	3.5	6.6	3.6	7.3	3.5
	12.0	3.9	2.7	4.6	3.0	5.3	3.3	5.6	3.4	5.9	3.5	6.6	3.6	7.2	3.5
	14.0	3.9	2.7	4.6	3.0	5.3	3.3	5.6	3.4	5.9	3.5	6.6	3.6	7.1	3.5
	16.0	3.9	2.7	4.6	3.0	5.3	3.3	5.6	3.4	5.9	3.5	6.6	3.6	7.0	3.4
	18.0	3.9	2.7	4.6	3.0	5.3	3.3	5.6	3.4	5.9	3.5	6.6	3.6	6.8	3.4
	20.0	3.9	2.7	4.6	3.0	5.3	3.3	5.6	3.4	5.9	3.5	6.6	3.6	6.7	3.3
	21.0	3.9	2.7	4.6	3.0	5.3	3.3	5.6	3.4	5.9	3.5	6.6	3.6	6.6	3.3
	23.0	3.9	2.7	4.6	3.0	5.3	3.3	5.6	3.4	5.9	3.5	6.6	3.6	6.6	3.3
	25.0	3.9	2.7	4.6	3.0	5.3	3.3	5.6	3.4	5.9	3.5	6.6	3.6	6.5	3.2
	27.0	3.9	2.7	4.6	3.0	5.3	3.3	5.6	3.4	5.9	3.5	6.4	3.5	6.4	3.2
	29.0	3.9	2.7	4.6	3.0	5.3	3.3	5.6	3.4	5.9	3.5	6.3	3.5	6.4	3.3
	31.0	3.9	2.7	4.6	3.0	5.3	3.3	5.6	3.4	5.9	3.5	6.2	3.4	6.2	3.2
	33.0	3.9	2.7	4.6	3.0	5.3	3.3	5.6	3.4	5.9	3.5	6.2	3.4	6.2	3.2
	35.0	3.9	2.7	4.6	3.0	5.3	3.3	5.6	3.4	5.9	3.5	6.0	3.3	6.0	3.1
	37.0	3.9	2.7	4.6	3.0	5.3	3.3	5.6	3.4	5.9	3.5	5.9	3.2	6.0	3.1
	39.0	3.9	2.7	4.6	3.0	5.3	3.3	5.6	3.4	5.7	3.4	5.8	3.2	6.0	3.1
42.0	3.9	2.7	4.6	3.0	5.3	3.3	5.6	3.4	5.7	3.4	5.8	3.2	6.0	3.1	
44.0	3.9	2.7	4.6	3.0	5.3	3.3	5.6	3.4	5.7	3.4	5.8	3.2	6.0	3.1	
46.0	3.9	2.7	4.6	3.0	5.3	3.3	5.6	3.4	5.7	3.7	5.8	3.2	6.0	3.1	
7.1	10.0	4.9	3.6	5.8	4.0	6.7	4.3	7.1	4.5	7.5	4.4	8.4	4.5	9.2	4.6
	12.0	4.9	3.6	5.8	4.0	6.7	4.3	7.1	4.5	7.5	4.4	8.4	4.5	9.1	4.5
	14.0	4.9	3.6	5.8	4.0	6.7	4.3	7.1	4.5	7.5	4.4	8.4	4.5	9.0	4.5
	16.0	4.9	3.6	5.8	4.0	6.7	4.3	7.1	4.5	7.5	4.4	8.4	4.5	8.9	4.4
	18.0	4.9	3.6	5.8	4.0	6.7	4.3	7.1	4.5	7.5	4.4	8.4	4.5	8.7	4.3
	20.0	4.9	3.6	5.8	4.0	6.7	4.3	7.1	4.5	7.5	4.4	8.4	4.5	8.5	4.2
	21.0	4.9	3.6	5.8	4.0	6.7	4.3	7.1	4.5	7.5	4.4	8.4	4.5	8.4	4.2
	23.0	4.9	3.6	5.8	4.0	6.7	4.3	7.1	4.5	7.5	4.4	8.4	4.5	8.3	4.1
	25.0	4.9	3.6	5.8	4.0	6.7	4.3	7.1	4.5	7.5	4.4	8.4	4.5	8.2	4.1
	27.0	4.9	3.6	5.8	4.0	6.7	4.3	7.1	4.5	7.5	4.4	8.1	4.3	8.2	4.1
	29.0	4.9	3.6	5.8	4.0	6.7	4.3	7.1	4.5	7.5	4.5	8.0	4.3	8.1	4.1
	31.0	4.9	3.6	5.8	4.0	6.7	4.3	7.1	4.5	7.5	4.5	7.9	4.3	7.8	4.0
	33.0	4.9	3.6	5.8	4.0	6.7	4.3	7.1	4.5	7.5	4.5	7.8	4.2	7.8	4.0
	35.0	4.9	3.6	5.8	4.0	6.7	4.3	7.1	4.5	7.5	4.5	7.6	4.1	7.7	3.9
	37.0	4.9	3.6	5.8	4.0	6.7	4.3	7.1	4.5	7.4	4.4	7.5	4.1	7.6	4.0
	39.0	4.9	3.6	5.8	4.0	6.7	4.3	7.1	4.5	7.2	4.3	7.4	4.1	7.6	4.0
42.0	4.9	3.6	5.8	4.0	6.7	4.3	7.1	4.5	7.2	4.3	7.4	4.1	7.6	4.0	
44.0	4.9	3.6	5.8	4.0	6.7	4.3	7.1	4.5	7.2	4.3	7.4	4.1	7.6	4.0	
46.0	4.9	3.6	5.8	4.0	6.7	4.3	7.1	4.5	7.2	4.3	7.4	4.1	7.6	4.0	

Abbreviations:
 TC: Total capacity
 SC: Sensible capacity

Notes:
 1. Shaded cells indicate rating condition.

Table continued on next page ...

The 2nd Generation DC Series VRF Indoor Units

Table 6.1: Ceiling & floor cooling capacity (continued)

Capacity (kW)	Outdoor air temperature (°C DB)	Indoor air temperature (°C WB/DB)													
		14/20		16/23		18/26		19/27		20/28		22/30		24/32	
		TC	SC	TC	SC	TC	SC	TC	SC	TC	SC	TC	SC	TC	SC
		kW	kW	kW	kW	kW	kW	kW	kW	kW	kW	kW	kW	kW	kW
8.0	10.0	5.5	4.4	6.6	4.9	7.5	5.3	8.0	5.5	8.4	5.4	9.4	5.5	10.4	5.6
	12.0	5.5	4.4	6.6	4.9	7.5	5.3	8.0	5.5	8.4	5.4	9.4	5.5	10.2	5.5
	14.0	5.5	4.4	6.6	4.9	7.5	5.3	8.0	5.5	8.4	5.4	9.4	5.5	10.2	5.5
	16.0	5.5	4.4	6.6	4.9	7.5	5.3	8.0	5.5	8.4	5.4	9.4	5.5	10.0	5.4
	18.0	5.5	4.4	6.6	4.9	7.5	5.3	8.0	5.5	8.4	5.4	9.4	5.5	9.8	5.3
	20.0	5.5	4.4	6.6	4.9	7.5	5.3	8.0	5.5	8.4	5.4	9.4	5.5	9.6	5.2
	21.0	5.5	4.4	6.6	4.9	7.5	5.3	8.0	5.5	8.4	5.4	9.4	5.5	9.4	5.1
	23.0	5.5	4.4	6.6	4.9	7.5	5.3	8.0	5.5	8.4	5.4	9.4	5.5	9.4	5.1
	25.0	5.5	4.4	6.6	4.9	7.5	5.3	8.0	5.5	8.4	5.4	9.4	5.5	9.3	5.0
	27.0	5.5	4.4	6.6	4.9	7.5	5.3	8.0	5.5	8.4	5.4	9.1	5.3	9.2	5.1
	29.0	5.5	4.4	6.6	4.9	7.5	5.3	8.0	5.5	8.4	5.5	9.0	5.3	9.1	5.0
	31.0	5.5	4.4	6.6	4.9	7.5	5.3	8.0	5.5	8.4	5.5	8.9	5.2	8.8	4.8
	33.0	5.5	4.4	6.6	4.9	7.5	5.3	8.0	5.5	8.4	5.5	8.8	5.2	8.8	4.8
	35.0	5.5	4.4	6.6	4.9	7.5	5.3	8.0	5.5	8.4	5.5	8.6	5.1	8.6	4.8
	37.0	5.5	4.4	6.6	4.9	7.5	5.3	8.0	5.5	8.3	5.4	8.4	5.0	8.6	4.9
	39.0	5.5	4.4	6.6	4.9	7.5	5.3	8.0	5.5	8.1	5.3	8.3	5.0	8.6	4.9
42.0	5.5	4.4	6.6	4.9	7.5	5.3	8.0	5.5	8.1	5.3	8.3	5.0	8.6	4.9	
44.0	5.5	4.4	6.6	4.9	7.5	5.3	8.0	5.5	8.1	5.3	8.3	5.0	8.6	4.9	
46.0	5.5	4.4	6.6	4.9	7.5	5.3	8.0	5.5	8.1	5.3	8.3	5.0	8.6	4.9	
9.0	10.0	6.2	4.9	7.3	5.3	8.4	5.8	9.0	5.9	9.6	6.0	10.6	6.1	11.7	6.0
	12.0	6.2	4.9	7.3	5.3	8.4	5.8	9.0	5.9	9.6	6.0	10.6	6.1	11.5	5.9
	14.0	6.2	4.9	7.3	5.3	8.4	5.8	9.0	5.9	9.6	6.0	10.6	6.1	11.4	5.9
	16.0	6.2	4.9	7.3	5.3	8.4	5.8	9.0	5.9	9.6	6.0	10.6	6.1	11.3	5.8
	18.0	6.2	4.9	7.3	5.3	8.4	5.8	9.0	5.9	9.6	6.0	10.6	6.1	11.0	5.8
	20.0	6.2	4.9	7.3	5.3	8.4	5.8	9.0	5.9	9.6	6.0	10.6	6.1	10.8	5.7
	21.0	6.2	4.9	7.3	5.3	8.4	5.8	9.0	5.9	9.6	6.0	10.6	6.1	10.6	5.6
	23.0	6.2	4.9	7.3	5.3	8.4	5.8	9.0	5.9	9.6	6.0	10.6	6.1	10.5	5.5
	25.0	6.2	4.9	7.3	5.3	8.4	5.8	9.0	5.9	9.6	6.0	10.6	6.1	10.4	5.5
	27.0	6.2	4.9	7.3	5.3	8.4	5.8	9.0	5.9	9.6	6.0	10.3	5.9	10.4	5.4
	29.0	6.2	4.9	7.3	5.3	8.4	5.8	9.0	5.9	9.6	6.0	10.1	5.7	10.3	5.4
	31.0	6.2	4.9	7.3	5.3	8.4	5.8	9.0	5.9	9.6	6.0	10.0	5.7	9.9	5.3
	33.0	6.2	4.9	7.3	5.3	8.4	5.8	9.0	5.9	9.6	6.0	9.9	5.6	9.9	5.3
	35.0	6.2	4.9	7.3	5.3	8.4	5.8	9.0	5.9	9.5	6.0	9.6	5.5	9.7	5.3
	37.0	6.2	4.9	7.3	5.3	8.4	5.8	9.0	5.9	9.3	5.8	9.5	5.4	9.6	5.3
	39.0	6.2	4.9	7.3	5.3	8.4	5.8	9.0	5.9	9.2	5.7	9.4	5.3	9.6	5.3
42.0	6.2	4.9	7.3	5.3	8.4	5.8	9.0	5.9	9.2	5.7	9.4	5.3	9.6	5.3	
44.0	6.2	4.9	7.3	5.3	8.4	5.8	9.0	5.9	9.2	5.7	9.4	5.3	9.6	5.3	
46.0	6.2	4.9	7.3	5.3	8.4	5.8	9.0	5.9	9.2	5.7	9.4	5.3	9.6	5.3	

Abbreviations:
 TC: Total capacity
 SC: Sensible capacity

Notes:
 1. Shaded cells indicate rating condition.

Table continued on next page ...

The 2nd Generation DC Series VRF Indoor Units

Table 6.1: Ceiling & floor cooling capacity (continued)

Capacity (kW)	Outdoor air temperature (°C DB)	Indoor air temperature (°C WB/DB)													
		14/20		16/23		18/26		19/27		20/28		22/30		24/32	
		TC	SC	TC	SC	TC	SC	TC	SC	TC	SC	TC	SC	TC	SC
		kW	kW	kW	kW	kW	kW	kW	kW	kW	kW	kW	kW	kW	kW
11.2	10.0	7.7	5.9	9.1	6.5	10.5	7.1	11.2	7.2	11.9	7.4	13.3	7.6	15.5	8.2
	12.0	7.7	5.9	9.1	6.5	10.5	7.1	11.2	7.2	11.9	7.4	13.3	7.6	14.4	7.7
	14.0	7.7	5.9	9.1	6.5	10.5	7.1	11.2	7.2	11.9	7.4	13.3	7.6	14.2	7.6
	16.0	7.7	5.9	9.1	6.5	10.5	7.1	11.2	7.2	11.9	7.4	13.3	7.6	14.1	7.5
	18.0	7.7	5.9	9.1	6.5	10.5	7.1	11.2	7.2	11.9	7.4	13.3	7.6	14.0	7.5
	20.0	7.7	5.9	9.1	6.5	10.5	7.1	11.2	7.2	11.9	7.4	13.3	7.6	13.9	7.4
	21.0	7.7	5.9	9.1	6.5	10.5	7.1	11.2	7.2	11.9	7.4	13.3	7.6	13.8	7.4
	23.0	7.7	5.9	9.1	6.5	10.5	7.1	11.2	7.2	11.9	7.4	13.1	7.5	13.7	7.3
	25.0	7.7	5.9	9.1	6.5	10.5	7.1	11.2	7.2	11.9	7.4	13.0	7.4	13.6	7.2
	27.0	7.7	5.9	9.1	6.5	10.5	7.1	11.2	7.2	11.9	7.4	12.9	7.3	13.4	7.2
	29.0	7.7	5.9	9.1	6.5	10.5	7.1	11.2	7.2	11.9	7.4	12.8	7.3	13.3	7.2
	31.0	7.7	5.9	9.1	6.5	10.5	7.1	11.2	7.2	11.9	7.4	12.7	7.2	12.8	6.9
	33.0	7.7	5.9	9.1	6.5	10.5	7.1	11.2	7.2	11.9	7.4	12.5	7.2	12.5	6.8
	35.0	7.7	5.9	9.1	6.5	10.5	7.1	11.2	7.2	11.8	7.4	12.4	7.1	12.3	6.7
	37.0	7.7	5.9	9.1	6.5	10.5	7.1	11.2	7.2	11.6	7.3	12.3	7.0	12.1	6.6
	39.0	7.7	5.9	9.1	6.5	10.5	7.1	11.2	7.2	11.4	7.1	12.2	7.0	11.9	6.6
42.0	7.7	6.0	9.1	6.6	10.4	7.2	11.2	7.3	11.4	7.1	11.6	6.6	12.0	6.6	
44.0	7.7	6.0	9.1	6.6	10.4	7.2	11.2	7.3	11.4	7.1	11.6	6.6	12.0	6.6	
46.0	7.7	6.0	9.1	6.6	10.4	7.2	11.2	7.3	11.4	7.1	11.6	6.6	12.0	6.6	
14.0	10.0	9.7	7.2	11.3	7.9	13.2	8.8	14.0	9.0	14.8	9.0	16.7	9.3	18.2	9.4
	12.0	9.7	7.2	11.3	7.9	13.2	8.8	14.0	9.0	14.8	9.0	16.7	9.3	17.9	9.2
	14.0	9.7	7.2	11.3	7.9	13.2	8.8	14.0	9.0	14.8	9.0	16.7	9.3	17.8	9.2
	16.0	9.7	7.2	11.3	7.9	13.2	8.8	14.0	9.0	14.8	9.0	16.7	9.3	17.5	9.0
	18.0	9.7	7.2	11.3	7.9	13.2	8.8	14.0	9.0	14.8	9.0	16.7	9.3	17.1	8.8
	20.0	9.7	7.2	11.3	7.9	13.2	8.8	14.0	9.0	14.8	9.0	16.7	9.3	16.8	8.7
	21.0	9.7	7.2	11.3	7.9	13.2	8.8	14.0	9.0	14.8	9.0	16.7	9.3	16.5	8.5
	23.0	9.7	7.2	11.3	7.9	13.2	8.8	14.0	9.0	14.8	9.0	16.4	9.3	16.4	8.4
	25.0	9.7	7.2	11.3	7.9	13.2	8.8	14.0	9.0	14.8	9.0	16.2	9.3	16.2	8.4
	27.0	9.7	7.2	11.3	7.9	13.2	8.8	14.0	9.0	14.8	9.0	16.1	9.2	16.1	8.4
	29.0	9.7	7.2	11.3	7.9	13.2	8.8	14.0	9.0	14.8	9.0	16.0	9.1	16.0	8.4
	31.0	9.7	7.2	11.3	7.9	13.2	8.8	14.0	9.0	14.8	9.0	15.8	9.0	15.4	8.1
	33.0	9.7	7.2	11.3	7.9	13.2	8.8	14.0	9.0	14.8	9.0	15.7	8.9	15.4	8.1
	35.0	9.7	7.2	11.3	7.9	13.2	8.8	14.0	9.0	14.7	8.9	15.1	8.6	15.1	8.1
	37.0	9.7	7.2	11.3	7.9	13.2	8.8	14.0	9.0	14.6	8.8	15.1	8.6	15.0	8.0
	39.0	9.7	7.2	11.3	7.9	13.2	8.8	14.0	9.0	14.3	8.7	14.6	8.4	15.0	8.1
42.0	9.7	7.2	11.3	7.9	13.2	8.8	14.0	9.0	14.3	8.7	14.6	8.4	15.0	8.1	
44.0	9.7	7.2	11.3	7.9	13.2	8.8	14.0	9.0	14.3	8.7	14.6	8.4	15.0	8.1	
46.0	9.7	7.2	11.3	7.9	13.2	8.8	14.0	9.0	14.3	8.7	14.6	8.4	15.0	8.1	

Abbreviations:

TC: Total capacity

SC: Sensible capacity

Notes:

1. Shaded cells indicate rating condition.

The 2nd Generation DC Series VRF Indoor Units

6.2 Heating Capacity Table

Table 6.2: Ceiling & floor heating capacity

Capacity (kW)	Outdoor air temperature (°C)		Indoor air temperature (°C DB)					
			16	18	20	21	22	24
	WB	DB	TC	TC	TC	TC	TC	TC
3.6	-20	-19.8	2.24	2.24	2.24	2.24	2.24	2.24
	-19	-18.8	2.40	2.40	2.40	2.40	2.40	2.40
	-17	-16.7	2.52	2.52	2.52	2.52	2.52	2.52
	-15	-14.7	2.60	2.60	2.60	2.60	2.60	2.60
	-13.00	-12.60	2.68	2.68	2.68	2.68	2.68	2.68
	-11.00	-10.50	2.80	2.80	2.80	2.80	2.80	2.80
	-10.00	-9.50	2.92	2.92	2.92	2.92	2.92	2.92
	-9.10	-8.50	3.00	3.00	3.00	3.00	3.00	3.00
	-7.60	-7.00	3.04	3.04	3.04	3.04	3.04	3.04
	-5.60	-5.00	3.16	3.16	3.16	3.16	3.16	3.16
	-3.70	-3.00	3.32	3.32	3.32	3.32	3.32	3.32
	-0.70	0.00	3.56	3.56	3.56	3.56	3.56	3.36
	2.20	3.00	3.76	3.76	3.76	3.76	3.68	3.36
	4.10	5.00	3.88	3.88	3.88	3.88	3.68	3.36
	6.00	7.00	4.00	4.00	4.00	3.88	3.68	3.36
	7.90	9.00	4.12	4.12	4.00	3.88	3.68	3.36
	9.80	11.00	4.24	4.24	4.00	3.88	3.68	3.36
11.80	13.00	4.40	4.32	4.00	3.88	3.68	3.36	
13.70	15.00	4.52	4.32	4.00	3.88	3.68	3.36	
4.5	-20	-19.8	2.80	2.80	2.80	2.80	2.80	2.80
	-19	-18.8	3.00	3.00	3.00	3.00	3.00	3.00
	-17	-16.7	3.15	3.15	3.15	3.15	3.15	3.15
	-15	-14.7	3.25	3.25	3.25	3.25	3.25	3.25
	-13.00	-12.60	3.35	3.35	3.35	3.35	3.35	3.35
	-11.00	-10.50	3.50	3.50	3.50	3.50	3.50	3.50
	-10.00	-9.50	3.65	3.65	3.65	3.65	3.65	3.65
	-9.10	-8.50	3.75	3.75	3.75	3.75	3.75	3.75
	-7.60	-7.00	3.80	3.80	3.80	3.80	3.80	3.80
	-5.60	-5.00	3.95	3.95	3.95	3.95	3.95	3.95
	-3.70	-3.00	4.15	4.15	4.15	4.15	4.15	4.15
	-0.70	0.00	4.45	4.45	4.45	4.45	4.45	4.20
	2.20	3.00	4.70	4.70	4.70	4.70	4.60	4.20
	4.10	5.00	4.85	4.85	4.85	4.85	4.60	4.20
	6.00	7.00	5.00	5.00	5.00	4.85	4.60	4.20
	7.90	9.00	5.15	5.15	5.00	4.85	4.60	4.20
	9.80	11.00	5.30	5.30	5.00	4.85	4.60	4.20
11.80	13.00	5.50	5.40	5.00	4.85	4.60	4.20	
13.70	15.00	5.65	5.40	5.00	4.85	4.60	4.20	

Abbreviations:
TC: Total capacity

Notes:
1. Shaded cells indicate rating condition.

Table continued on next page ...

The 2nd Generation DC Series VRF Indoor Units

Table 6.2: Ceiling & floor heating capacity (continued)

Capacity (kW)	Outdoor air temperature (°C)		Indoor air temperature (°C DB)					
			16	18	20	21	22	24
	WB	DB	TC	TC	TC	TC	TC	TC
5.6	-20	-19.8	3.53	3.53	3.53	3.53	3.53	3.53
	-19	-18.8	3.78	3.78	3.78	3.78	3.78	3.78
	-17	-16.7	3.97	3.97	3.97	3.97	3.97	3.97
	-15	-14.7	4.10	4.10	4.10	4.10	4.10	4.10
	-13.00	-12.60	4.22	4.22	4.22	4.22	4.22	4.22
	-11.00	-10.50	4.41	4.41	4.41	4.41	4.41	4.41
	-10.00	-9.50	4.60	4.60	4.60	4.60	4.60	4.60
	-9.10	-8.50	4.73	4.73	4.73	4.73	4.73	4.73
	-7.60	-7.00	4.79	4.79	4.79	4.79	4.79	4.79
	-5.60	-5.00	4.98	4.98	4.98	4.98	4.98	4.98
	-3.70	-3.00	5.23	5.23	5.23	5.23	5.23	5.23
	-0.70	0.00	5.61	5.61	5.61	5.61	5.61	5.29
	2.20	3.00	5.92	5.92	5.92	5.92	5.80	5.29
	4.10	5.00	6.11	6.11	6.11	6.11	5.80	5.29
	6.00	7.00	6.30	6.30	6.30	6.11	5.80	5.29
	7.90	9.00	6.49	6.49	6.30	6.11	5.80	5.29
9.80	11.00	6.68	6.68	6.30	6.11	5.80	5.29	
11.80	13.00	6.93	6.80	6.30	6.11	5.80	5.29	
13.70	15.00	7.12	6.80	6.30	6.11	5.80	5.29	
7.1	-20	-19.8	4.48	4.48	4.48	4.48	4.48	4.48
	-19	-18.8	4.80	4.80	4.80	4.80	4.80	4.80
	-17	-16.7	5.04	5.04	5.04	5.04	5.04	5.04
	-15	-14.7	5.20	5.20	5.20	5.20	5.20	5.20
	-13.00	-12.60	5.36	5.36	5.36	5.36	5.36	5.36
	-11.00	-10.50	5.60	5.60	5.60	5.60	5.60	5.60
	-10.00	-9.50	5.84	5.84	5.84	5.84	5.84	5.84
	-9.10	-8.50	6.00	6.00	6.00	6.00	6.00	6.00
	-7.60	-7.00	6.08	6.08	6.08	6.08	6.08	6.08
	-5.60	-5.00	6.32	6.32	6.32	6.32	6.32	6.32
	-3.70	-3.00	6.64	6.64	6.64	6.64	6.64	6.64
	-0.70	0.00	7.12	7.12	7.12	7.12	7.12	6.72
	2.20	3.00	7.52	7.52	7.52	7.52	7.36	6.72
	4.10	5.00	7.76	7.76	7.76	7.76	7.36	6.72
	6.00	7.00	8.00	8.00	8.00	7.76	7.36	6.72
	7.90	9.00	8.24	8.24	8.00	7.76	7.36	6.72
9.80	11.00	8.48	8.48	8.00	7.76	7.36	6.72	
11.80	13.00	8.80	8.64	8.00	7.76	7.36	6.72	
13.70	15.00	9.04	8.64	8.00	7.76	7.36	6.72	

Abbreviations:
TC: Total capacity

Notes:
1. Shaded cells indicate rating condition.

Table continued on next page ...

The 2nd Generation DC Series VRF Indoor Units

Table 6.2: Ceiling & floor heating capacity (continued)

Capacity (kW)	Outdoor air temperature (°C)		Indoor air temperature (°C DB)					
			16	18	20	21	22	24
	WB	DB	TC	TC	TC	TC	TC	TC
8.0	-20	-19.8	5.04	5.04	5.04	5.04	5.04	5.04
	-19	-18.8	5.40	5.40	5.40	5.40	5.40	5.40
	-17	-16.7	5.67	5.67	5.67	5.67	5.67	5.67
	-15	-14.7	5.85	5.85	5.85	5.85	5.85	5.85
	-13.00	-12.60	6.03	6.03	6.03	6.03	6.03	6.03
	-11.00	-10.50	6.30	6.30	6.30	6.30	6.30	6.30
	-10.00	-9.50	6.57	6.57	6.57	6.57	6.57	6.57
	-9.10	-8.50	6.75	6.75	6.75	6.75	6.75	6.75
	-7.60	-7.00	6.84	6.84	6.84	6.84	6.84	6.84
	-5.60	-5.00	7.11	7.11	7.11	7.11	7.11	7.11
	-3.70	-3.00	7.47	7.47	7.47	7.47	7.47	7.47
	-0.70	0.00	8.01	8.01	8.01	8.01	8.01	7.56
	2.20	3.00	8.46	8.46	8.46	8.46	8.28	7.56
	4.10	5.00	8.73	8.73	8.73	8.73	8.28	7.56
	6.00	7.00	9.00	9.00	9.00	8.73	8.28	7.56
	7.90	9.00	9.27	9.27	9.00	8.73	8.28	7.56
9.80	11.00	9.54	9.54	9.00	8.73	8.28	7.56	
11.80	13.00	9.90	9.72	9.00	8.73	8.28	7.56	
13.70	15.00	10.17	9.72	9.00	8.73	8.28	7.56	
9.0	-20	-19.8	5.60	5.04	5.60	5.60	5.60	5.60
	-19	-18.8	6.00	5.40	6.00	6.00	6.00	6.00
	-17	-16.7	6.30	6.30	6.30	6.30	6.30	6.30
	-15	-14.7	6.50	6.50	6.50	6.50	6.50	6.50
	-13.00	-12.60	6.70	6.70	6.70	6.70	6.70	6.70
	-11.00	-10.50	7.00	7.00	7.00	7.00	7.00	7.00
	-10.00	-9.50	7.30	7.30	7.30	7.30	7.30	7.30
	-9.10	-8.50	7.50	7.50	7.50	7.50	7.50	7.50
	-7.60	-7.00	7.60	7.60	7.60	7.60	7.60	7.60
	-5.60	-5.00	7.90	7.90	7.90	7.90	7.90	7.90
	-3.70	-3.00	8.30	8.30	8.30	8.30	8.30	8.30
	-0.70	0.00	8.90	8.90	8.90	8.90	8.90	8.40
	2.20	3.00	9.40	9.40	9.40	9.40	9.20	8.40
	4.10	5.00	9.70	9.70	9.70	9.70	9.20	8.40
	6.00	7.00	10.00	10.00	10.00	9.70	9.20	8.40
	7.90	9.00	10.30	10.30	10.00	9.70	9.20	8.40
9.80	11.00	10.60	10.60	10.00	9.70	9.20	8.40	
11.80	13.00	11.00	10.80	10.00	9.70	9.20	8.40	
13.70	15.00	11.30	10.80	10.00	9.70	9.20	8.40	

Abbreviations:
TC: Total capacity

Notes:
1. Shaded cells indicate rating condition.

Table continued on next page ...

The 2nd Generation DC Series VRF Indoor Units

Table 6.2: Ceiling & floor heating capacity (continued)

Capacity (kW)	Outdoor air temperature (°C)		Indoor air temperature (°C DB)					
			16	18	20	21	22	24
	WB	DB	TC kW	TC kW	TC kW	TC kW	TC kW	TC kW
11.2	-20	-19.8	7.00	7.00	7.00	7.00	7.00	7.00
	-19	-18.8	7.50	7.50	7.50	7.50	7.50	7.50
	-17	-16.7	7.88	7.88	7.88	7.88	7.88	7.88
	-15	-14.7	8.13	8.13	8.13	8.13	8.13	8.13
	-13.00	-12.60	8.38	8.38	8.38	8.38	8.38	8.38
	-11.00	-10.50	8.75	8.75	8.75	8.75	8.75	8.75
	-10.00	-9.50	9.13	9.13	9.13	9.13	9.13	9.13
	-9.10	-8.50	9.38	9.38	9.38	9.38	9.38	9.38
	-7.60	-7.00	9.50	9.50	9.50	9.50	9.50	9.50
	-5.60	-5.00	9.88	9.88	9.88	9.88	9.88	9.88
	-3.70	-3.00	10.38	10.38	10.38	10.38	10.38	10.38
	-0.70	0.00	11.13	11.13	11.13	11.13	11.13	10.50
	2.20	3.00	11.75	11.75	11.75	11.75	11.50	10.50
	4.10	5.00	12.13	12.13	12.13	12.13	11.50	10.50
	6.00	7.00	12.50	12.50	12.50	12.13	11.50	10.50
	7.90	9.00	12.88	12.88	12.50	12.13	11.50	10.50
	9.80	11.00	13.25	13.25	12.50	12.13	11.50	10.50
11.80	13.00	13.75	13.50	12.50	12.13	11.50	10.50	
13.70	15.00	14.13	13.50	12.50	12.13	11.50	10.50	
14.0	-20	-19.8	8.96	8.96	8.96	8.96	8.96	8.96
	-19	-18.8	9.60	9.60	9.60	9.60	9.60	9.60
	-17	-16.7	10.08	10.08	10.08	10.08	10.08	10.08
	-15	-14.7	10.40	10.40	10.40	10.40	10.40	10.40
	-13.00	-12.60	11.04	11.04	11.04	11.04	11.04	11.04
	-11.00	-10.50	11.20	11.36	11.36	11.36	11.36	11.36
	-10.00	-9.50	11.68	11.68	11.68	11.68	11.68	11.68
	-9.10	-8.50	12.00	12.00	12.00	12.00	12.00	12.00
	-7.60	-7.00	12.16	12.16	12.16	12.16	12.16	12.16
	-5.60	-5.00	12.64	12.64	12.64	12.64	12.64	12.64
	-3.70	-3.00	13.28	13.28	13.28	13.28	13.28	13.28
	-0.70	0.00	14.24	14.24	14.24	14.24	14.24	13.44
	2.20	3.00	15.04	15.04	15.04	15.04	14.72	13.44
	4.10	5.00	15.52	15.52	15.52	15.52	14.72	13.44
	6.00	7.00	16.00	16.00	16.00	15.52	14.72	13.44
	7.90	9.00	16.48	16.48	16.00	15.52	14.72	13.44
	9.80	11.00	16.96	16.96	16.00	15.52	14.72	13.44
11.80	13.00	17.60	17.28	16.00	15.52	14.72	13.44	
13.70	15.00	18.08	17.28	16.00	15.52	14.72	13.44	

Abbreviations:
TC: Total capacity

Notes:
1. Shaded cells indicate rating condition.

7 Electrical Characteristics

Table 7.1: Ceiling & floor electrical characteristics

Model	Power supply						Indoor fan motors	
	Hz	Volts	Min. volts	Max. volts	MCA	MFA	Rated motor output (kW)	FLA
MVD-36DLDN1	50	220-240	198	264	0.45	15	0.10	0.35
MVD-45DLDN1	50	220-240	198	264	1.20	15	0.10	0.93
MVD-56DLDN1	50	220-240	198	264	1.20	15	0.10	0.95
MVD-71DLDN1	50	220-240	198	264	1.20	15	0.10	0.95
MVD-80DLDN1	50	220-240	198	264	1.30	15	0.10	1.10
MVD-90DLDN1	50	220-240	198	264	1.30	15	0.10	1.10
MVD-112DLDN1	50	220-240	198	264	1.70	15	0.10+0.10	0.65+0.65
MVD-140DLDN1	50	220-240	198	264	1.70	15	0.10+0.10	0.65+0.65

Abbreviations:

MCA: Minimum Circuit Amps

MFA: Maximum Fuse Amps

FLA: Full Load Amps

The 2nd Generation DC Series VRF Indoor Units

8 Sound Levels

8.1 Overall

Table 8.1: Ceiling & floor sound pressure levels¹

Model name	Sound pressure levels dB(A)						
	SSH	SH	H	M	L	SL	SSL
MVD-36DLDN1	40	39	38	38	37	36	36
MVD-45DLDN1	43	42	41	41	39	38	38
MVD-56DLDN1	43	42	41	41	39	38	38
MVD-71DLDN1	43	42	41	41	39	38	38
MVD-80DLDN1	45	44	43	43	42	41	40
MVD-90DLDN1	45	44	43	43	42	41	40
MVD-112DLDN1	47	46	45	45	44	43	42
MVD-140DLDN1	47	46	45	45	44	43	42

Notes:

1. Sound pressure levels are measured in a semi-anechoic chamber. During in-situ operation, sound pressure levels may be higher as a result of ambient noise.

Figure 8.1: Ceiling & floor sound pressure level measurement

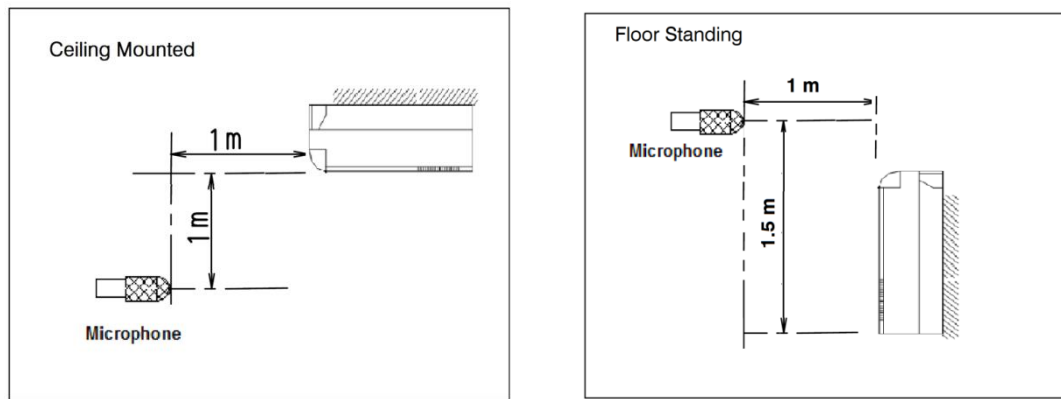

8.2 Octave Band Levels

Figure 8.2: MVD-36DLDN1 octave band levels

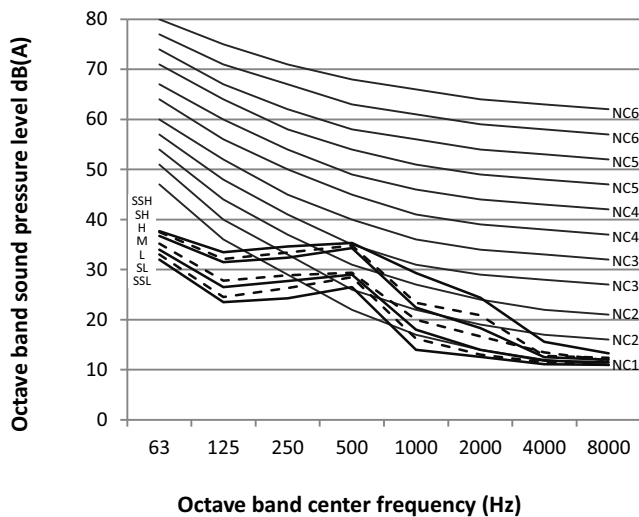
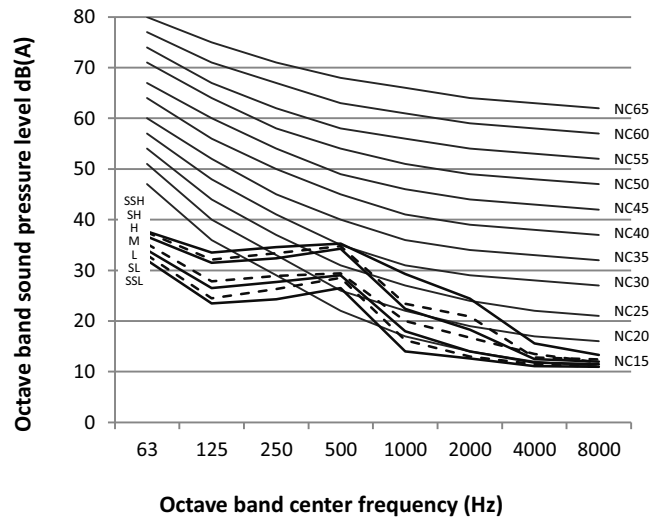

Figure 8.3: MVD-45(56,71)DLDN1 octave band levels



The 2nd Generation DC Series VRF Indoor Units

Figure 8.4: MVD-80(90)DLDN1 octave band levels

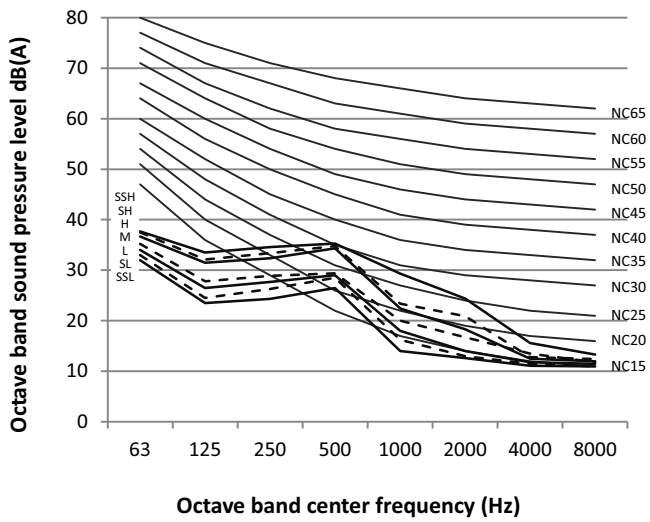
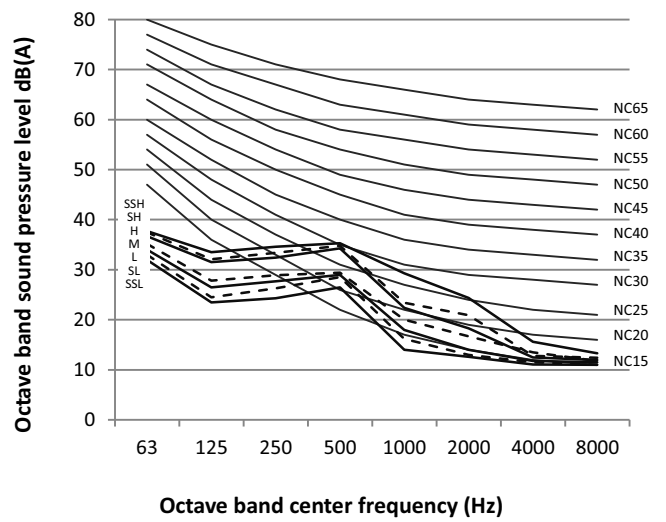

Figure 8.5: MVD-112(140)DLDN1 octave band levels



The 2nd Generation DC Series VRF Indoor Units

9 Error codes

With the exception of a mode conflict error, contact your supplier or service engineer if any of the error codes listed in the following table are displayed on the unit's display panel. If the mode conflict error is displayed and persists, contact your supplier or service engineer. These errors should only be investigated by a professional technician. The descriptions are provided in this manual for reference only.

Content	Digital display output	Possible causes
Mode conflict	E0	<ul style="list-style-type: none"> ♦ The indoor unit's operating mode conflicts with that of the outdoor units.
Communication error between indoor and outdoor units	E1	<ul style="list-style-type: none"> ♦ Communication wires between indoor and outdoor units not connected properly. ♦ Interference from high voltage wires or other sources of electromagnetic radiation. ♦ Communication wire too long. ♦ Damaged main PCB.
Indoor ambient temperature sensor (T1) error	E2	<ul style="list-style-type: none"> ♦ Temperature sensor not connected properly or has malfunctioned. ♦ Damaged main PCB.
Indoor heat exchanger mid-point temperature sensor (T2) error	E3	
Indoor heat exchanger outlet temperature sensor (T2B) error	E4	
Fan error	E6	<ul style="list-style-type: none"> ♦ Fan stuck or blocked. ♦ Fan motor not connected properly or has malfunctioned. ♦ Power supply abnormal. ♦ Damaged main PCB.
EEPROM mismatch	E7	<ul style="list-style-type: none"> ♦ Damaged main PCB.
EEV error	Eb	<ul style="list-style-type: none"> ♦ Line loosened or broken. ♦ The electronic expansion valve is stuck. ♦ Damaged main PCB.
Outdoor unit error	Ed	<ul style="list-style-type: none"> ♦ Outdoor unit error.
Water level error	EE	<ul style="list-style-type: none"> ♦ Water level float stuck. ♦ Water level switch not connected properly. ♦ Damaged main PCB. ♦ Drain pump has malfunctioned.
The indoor unit has not been assigned an address	FE	<ul style="list-style-type: none"> ♦ Indoor unit has not been assigned an address.

Notes:

Flashing rapidly means flashing twice per second; flashing slowly means flashing once per second.



MUNDO  CLIMA[®]



www.mundoclima.com

ASK FOR MORE INFORMATION

Phone: (+34) 93 446 27 80

eMail: info@mundoclima.com

TECHNICAL ASSISTANCE

Phone: (+34) 93 652 53 57