

# Wall Mounted Split

## Service manual



# Wall Mounted Split

<b>1 Specifications .....</b>	<b>4</b>
<b>2 Dimensions .....</b>	<b>6</b>
<b>3 Unit Placement .....</b>	<b>7</b>
<b>4 Piping Diagram .....</b>	<b>8</b>
<b>5 Wiring Diagram .....</b>	<b>9</b>
<b>6 Capacity Tables.....</b>	<b>13</b>
<b>7 Electrical Characteristics.....</b>	<b>21</b>
<b>8 Sound Levels .....</b>	<b>22</b>
<b>9 Error codes.....</b>	<b>24</b>

# The 2<sup>nd</sup> Generation DC Series VRF Indoor Units

## 1 Specifications

Table 1.1: MVD-22(28,36,45)GDN1 specifications

Model			MVD-22GDN1	MVD-28GDN1	MVD-36GDN1	MVD-45GDN1
Power supply			1 phase, 220-240V, 50Hz			
Cooling <sup>1</sup>	Capacity	kW	2.2	2.8	3.6	4.5
		kBtu/h	7.5	9.6	12.3	15.4
	Power input	W	28	28	30	40
Heating <sup>2</sup>	Capacity	kW	2.4	3.2	4.0	5.0
		kBtu/h	8.2	10.9	13.6	17.1
	Power input	W	28	28	30	40
Fan motor	Model		ZKFP-20-8-6	ZKFP-20-8-6	ZKSP-58-8-1	ZKSP-58-8-1
	Type		DC			
Indoor coil	Number of rows		1	2	1	2
	Tube pitch × row pitch	mm	21×13.37			
	Fin spacing	mm	1.3			
	Fin type		Hydrophilic aluminum			
	Tube OD and type	mm	Φ9.53 Inner-groove			
	Dimensions (L×H×W)	mm	585×315×13.37	585×315×26.74	701×315×13.37	701×315×26.74
	Number of circuits		2	3	3	5
Air flow rate <sup>3</sup>	m <sup>3</sup> /h	422/411/402/39 3/380/368/356	417/402/386/37 0/353/338/316	656/628/591/57 3/544/515/488	594/563/535/50 7/478/450/424	
Sound pressure level <sup>4</sup>	dB(A)	31/30/30/30/29/ 29/29	31/30/30/30/29/ 29/29	33/32/32/31/31/ 30/30	35/34/33/33/32/ 31/31	
Sound power level	dB(A)	46/45/45/45/44/ 44/44	46/45/45/45/44/ 44/44	48/47/47/46/46/ 45/45	50/49/48/48/47/ 46/46	
Unit	Net dimensions <sup>5</sup> (W×H×D)	mm	835×280×203		990×315×223	
	Packed dimensions (W×H×D)	mm	935×385×320		1085×420×335	
	Net/Gross weight	kg	8.4/12.1	9.5/13.1	11.4/15.5	12.8/16.9
Refrigerant type			R410A			
Throttle		Type	Electronic expansion valve			
Design pressure (H/L)		MPa	4.4/2.6			
Pipe connections	Liquid/Gas pipe	mm	Φ6.35/Φ12.7			
	Drain pipe	mm	OD Φ16			

Notes:

1. Indoor temperature 27°C DB, 19°C WB; outdoor temperature 35°C DB; equivalent refrigerant piping length 7.5m with zero level difference.
2. Indoor temperature 20°C DB; outdoor temperature 7°C DB, 6°C WB; equivalent refrigerant piping length 7.5m with zero level difference.
3. Fan motor speed and air flow rate are from the highest speed to the lowest speed, total 7 rates for each model.
4. Sound pressure level is from highest level to lowest level, total 7 levels for each model. Sound pressure level is measured in a semi-anechoic chamber.
5. Unit body dimensions given are the largest external dimensions of the unit, including hanger attachments.

# The 2<sup>nd</sup> Generation DC Series VRF Indoor Units

Table 1.2: MVD-56(71,80,90)GDN1 specifications

Model			MVD-56GDN1	MVD-71GDN1	MVD-80GDN1	MVD-90GDN1
Power supply			1 phase, 220-240V, 50Hz			
Cooling <sup>1</sup>	Capacity	kW	5.6	7.1	8.0	9.0
		kBtu/h	19.1	24.2	27.3	30.7
Power input		W	45	55	55	82
Heating <sup>2</sup>	Capacity	kW	6.3	8.0	9.0	10.0
		kBtu/h	21.5	27.3	30.7	34.1
Power input		W	45	55	55	82
Fan motor	Model		ZKSP-58-8-1	ZKSP-60-8-3	ZKSP-60-8-3	ZKSP-60-8-3
	Type		DC			
Indoor coil	Number of rows		2			
	Tube pitch × row pitch	mm	21×13.37			
	Fin spacing	mm	1.3			
	Fin type		Hydrophilic aluminum			
	Tube OD and type	mm	Φ9.53 Inner-groove			
	Dimensions (L×H×W)	mm	701×315×26.74	825×399×26.74	825×399×26.74	825×399×26.74
	Number of circuits		5			
Air flow rate <sup>3</sup>		m <sup>3</sup> /h	747/713/685/648 /613/578/547	1195/1130/1065/ 1005/940/875/80 9	1195/1130/1065/ 1005/940/875/80 9	1421/1300/1125/ 1067/1005/934/8 67
Sound pressure level <sup>4</sup>		dB(A)	38/37/36/36/35/3 4/34	44/43/42/39/38/3 7/36	44/43/42/39/38/3 7/36	48/46/45/43/41/4 0/38
Sound power level		dB(A)	53/52/51/51/50/4 9/49	59/58/57/54/53/5 2/51	59/58/57/54/53/5 2/51	63/61/60/58/56/5 5/53
Unit	Net dimensions <sup>5</sup> (W×H×D)		mm	990×315×223	1194×343×262	
	Packed dimensions (W×H×D)		mm	1085×420×335	1290×375×460	
	Net/Gross weight		kg	12.8/16.9	17.0/22.4	
Refrigerant type			R410A			
Throttle		Type	Electronic expansion valve			
Design pressure (H/L)		MPa	4.4/2.6			
Pipe connections	Liquid/Gas pipe		mm	Φ9.53/Φ15.9		
	Drain pipe		mm	OD Φ16		

Notes:

- Indoor temperature 27°C DB, 19°C WB; outdoor temperature 35°C DB; equivalent refrigerant piping length 7.5m with zero level difference.
- Indoor temperature 20°C DB; outdoor temperature 7°C DB, 6°C WB; equivalent refrigerant piping length 7.5m with zero level difference.
- Fan motor speed and air flow rate are from the highest speed to the lowest speed, total 7 rates for each model.
- Sound pressure level is from highest level to lowest level, total 7 levels for each model. Sound pressure level is measured in a semi-anechoic chamber.
- Unit body dimensions given are the largest external dimensions of the unit, including hanger attachments.

# The 2<sup>nd</sup> Generation DC Series VRF Indoor Units

## 2 Dimensions

### 2.1 Unit Dimensions

Figure 2.1: Wall mounted dimensions (unit: mm)

#### MVD-22GDN1, MVD-28GDN1

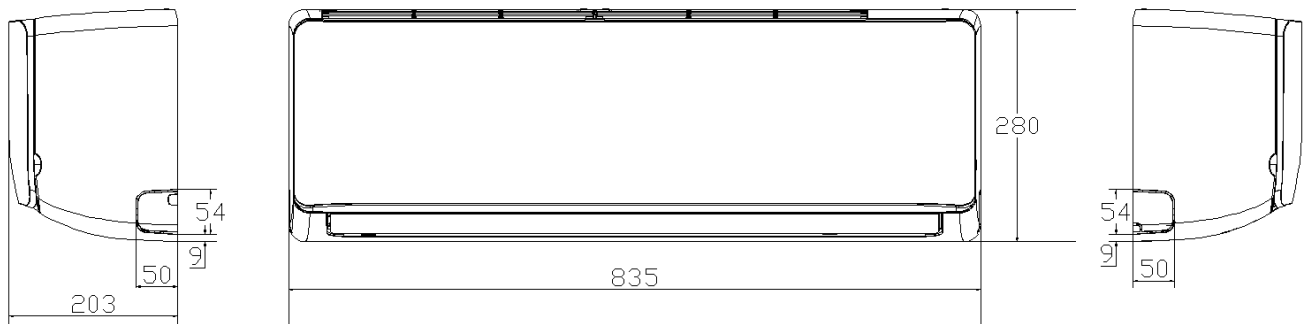

#### MVD-36GDN1, MVD-45GDN1, MVD-56GDN1

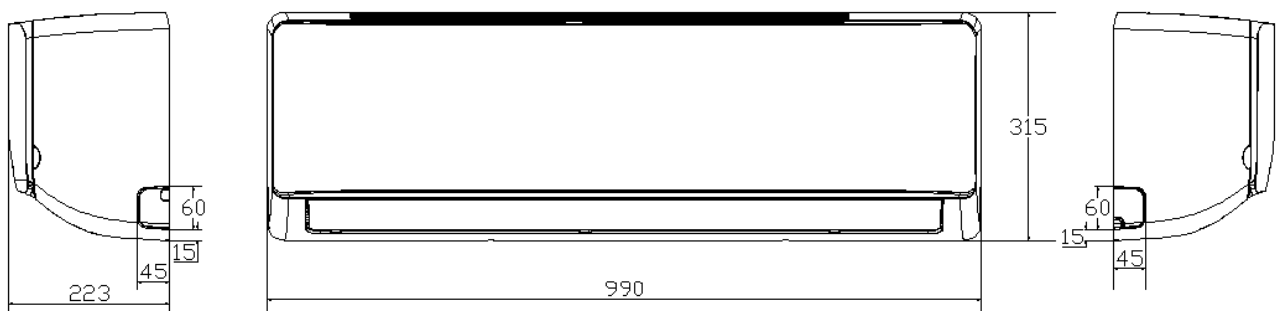

#### MVD-71GDN1, MVD-80GDN1, MVD-90GDN1

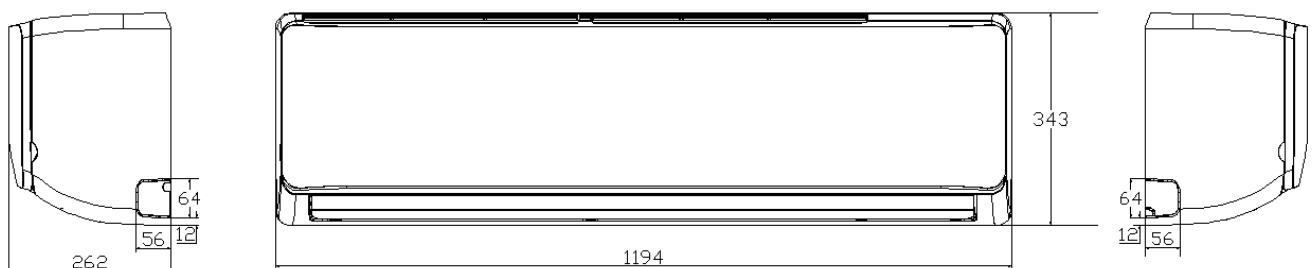

## 3 Unit Placement

### 3.1 Placement Considerations

Unit placement should take account of the following considerations:

- Units should not be installed in the following locations:
  - Where exposure to direct radiation from a high-temperature heat source or to interference from a source of electromagnetic radiation may occur.
  - Where dust or dirt may affect heat exchangers.
  - Where exposure to oil or to corrosive or harmful gases, such as acidic or alkaline gases, may occur.
  - Where exposure to salinity may occur, such as seaside locations.
  - Where highly flammable materials are present.
  - Where exposure to oily air may occur, such as a kitchen.
  - Where exposure to very high humidity may occur, such as a laundry.
- Units should be installed in positions where:
  - The ceiling is horizontal and is able to bear the unit's weight.
  - There are no obstructions that could impede the airflow into and out of the unit.
  - The airflow out of the unit can reach throughout the room.
  - There is sufficient space for access during installation, servicing and maintenance.
  - The refrigerant piping and drain piping can be easily connected to the refrigerant piping and drain piping systems.
  - Short-circuit ventilation (where outlet air returns quickly to a unit's air inlet) will not occur.

### 3.2 Space Requirements

Figure 3.1: Wall mounted space requirements (unit: mm)

#### MVD-22GDN1, MVD-28GDN1

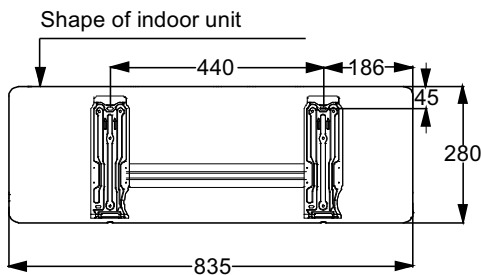

#### MVD-36GDN1, MVD-45GDN1, MVD-56GDN1

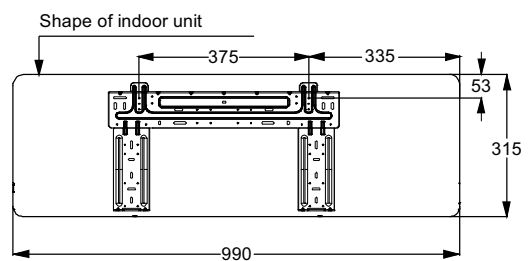

#### MVD-71GDN1, MVD-80GDN1, MVD-90GDN1

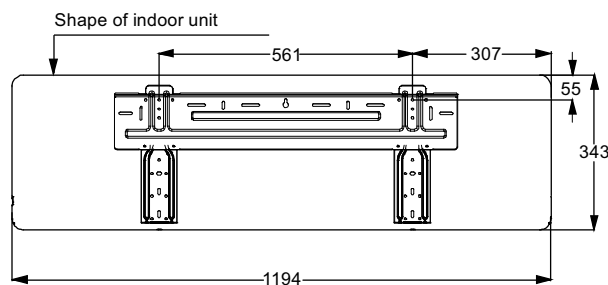

# The 2<sup>nd</sup> Generation DC Series VRF Indoor Units

## 4 Piping Diagram

Figure 4.1: Wall mounted piping diagram

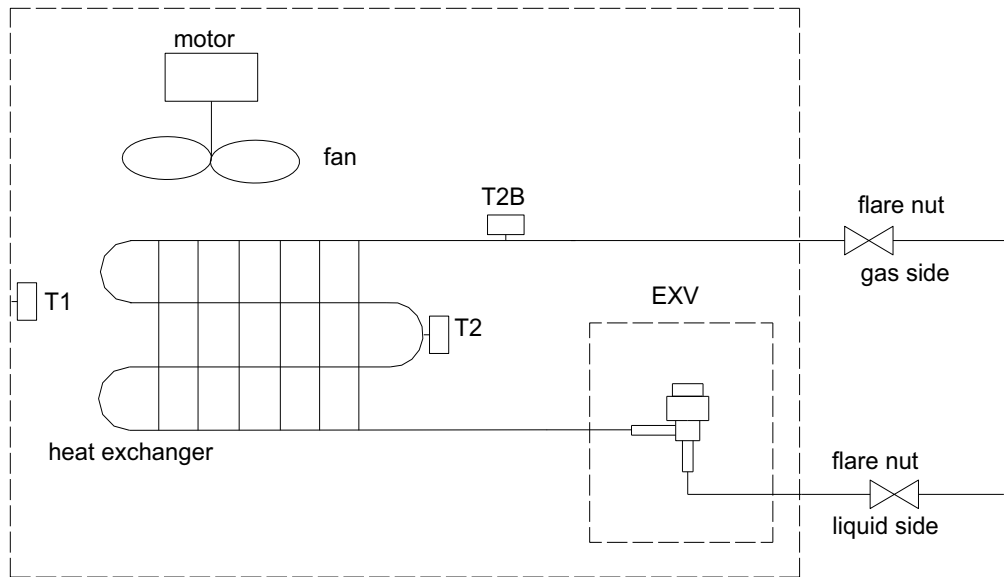

Legend	
T1	Indoor ambient temperature sensor
T2	Indoor heat exchanger mid-point temperature sensor
T2B	Indoor heat exchanger outlet temperature sensor

## 5 Wiring Diagram

Figure 5.1: 2.2/2.8kW Wall mounted wiring diagram

Code	Name	Code	Name	Code	Name
FM	Indoor fan motor	T1	Room temp. sensor	CS	Water level switch
GM	Swing motor	T2	Mid-pipe temp. sensor	XP1-5/XS1-5	Connectors
EEV	Electronic expansion valve	T2B	Outlet pipe temp. sensor		

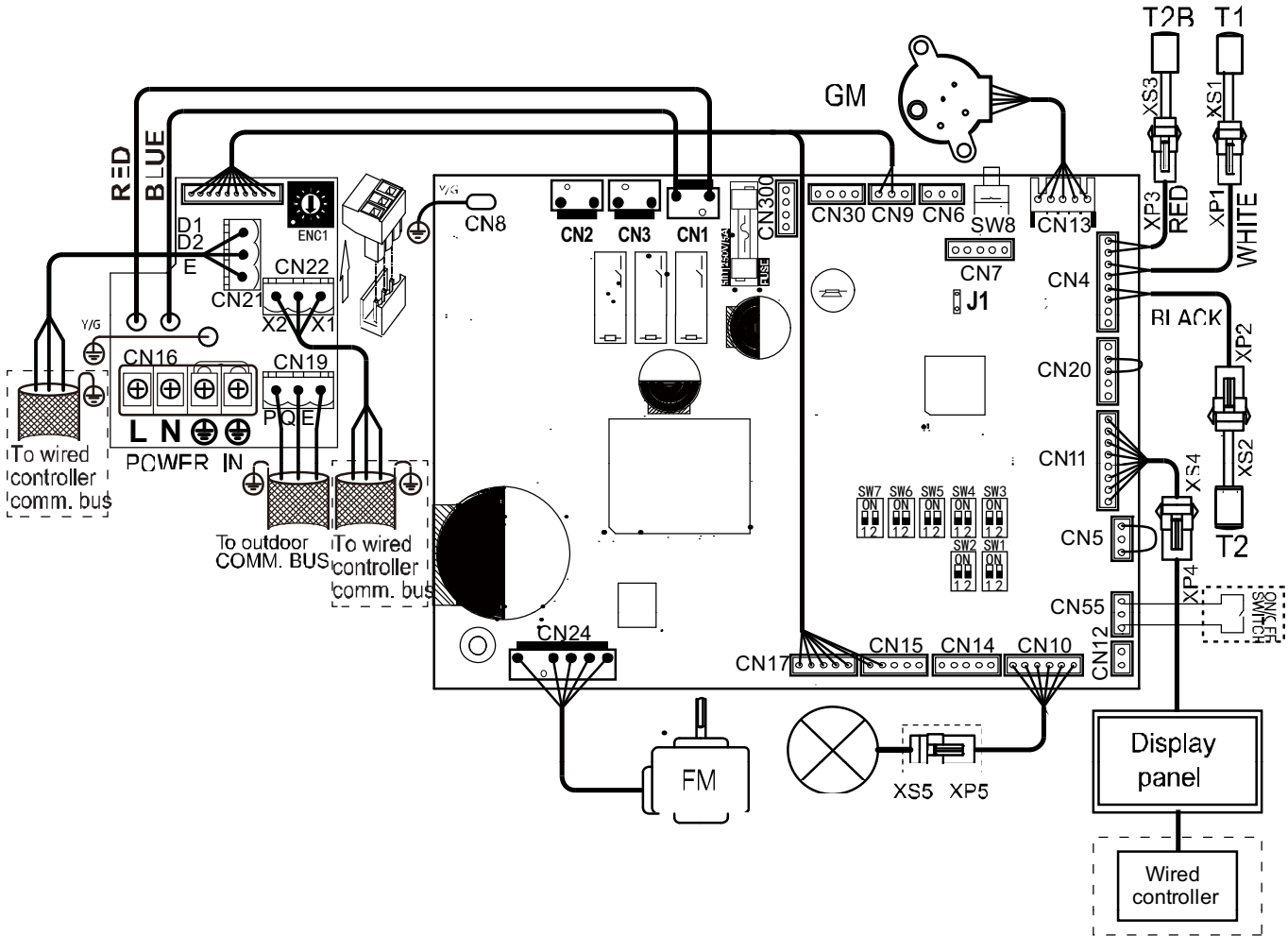



# The 2<sup>nd</sup> Generation DC Series VRF Indoor Units

Figure 5.2: 3.6/4.5/5.6kW Wall mounted wiring diagram

Code	Name	Code	Name	Code	Name
FM	Indoor fan motor	T1	Room temp. sensor	CS	Water level switch
GM	Swing motor	T2	Mid-pipe temp. sensor	XP1-5/XS1-5	Connectors
EEV	Electronic expansion valve	T2B	Outlet pipe temp. sensor		

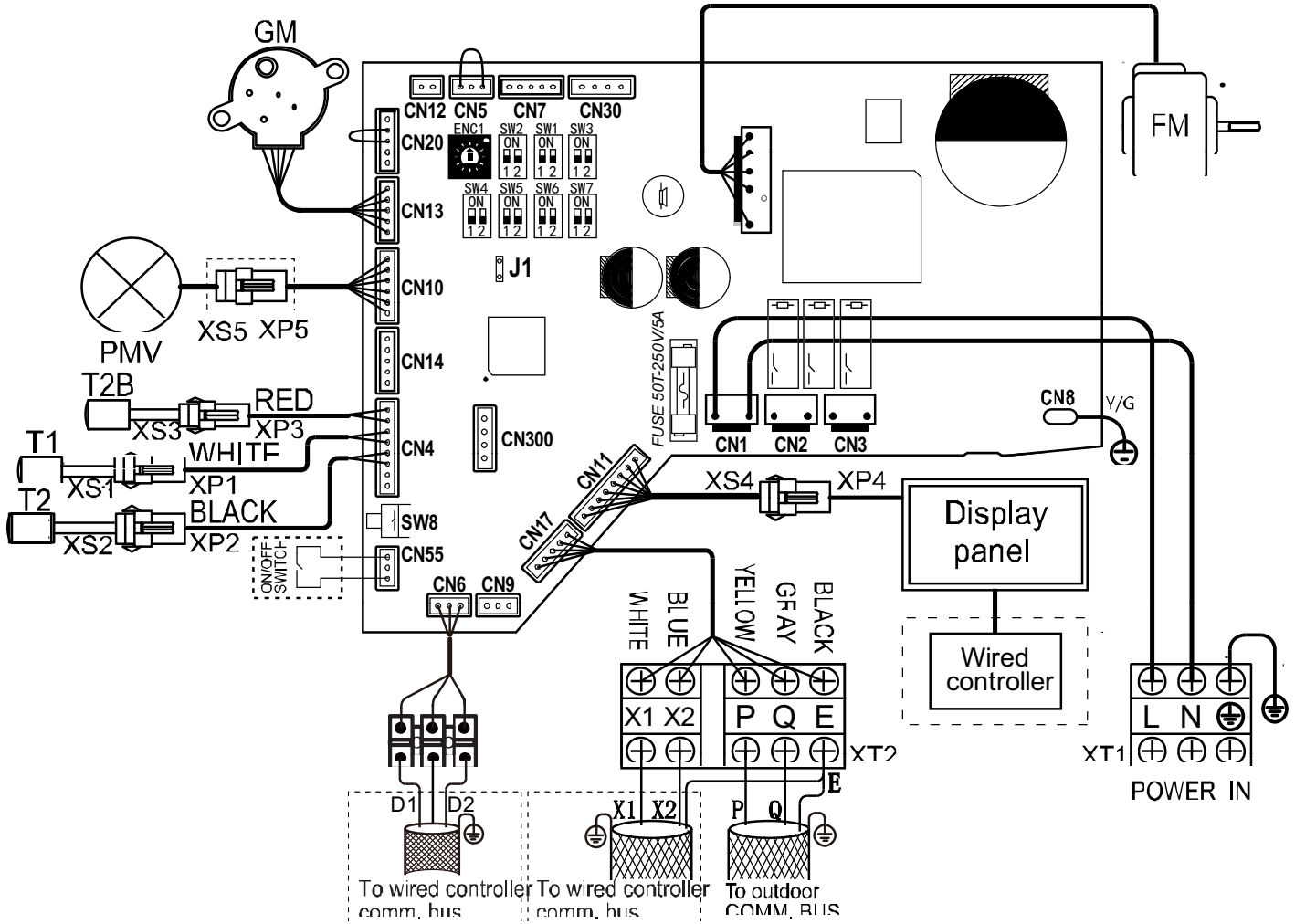

# The 2<sup>nd</sup> Generation DC Series VRF Indoor Units

Figure 5.3: 7.1/8.0/9.0kW Wall mounted wiring diagram

Code	Name	Code	Name	Code	Name
FM	Indoor fan motor	T1	Room temp. sensor	CS	Water level switch
GM	Swing motor	T2	Mid-pipe temp. sensor	XP1-5/XS1-5	Connectors
EEV	Electronic expansion valve	T2B	Outlet pipe temp. sensor		

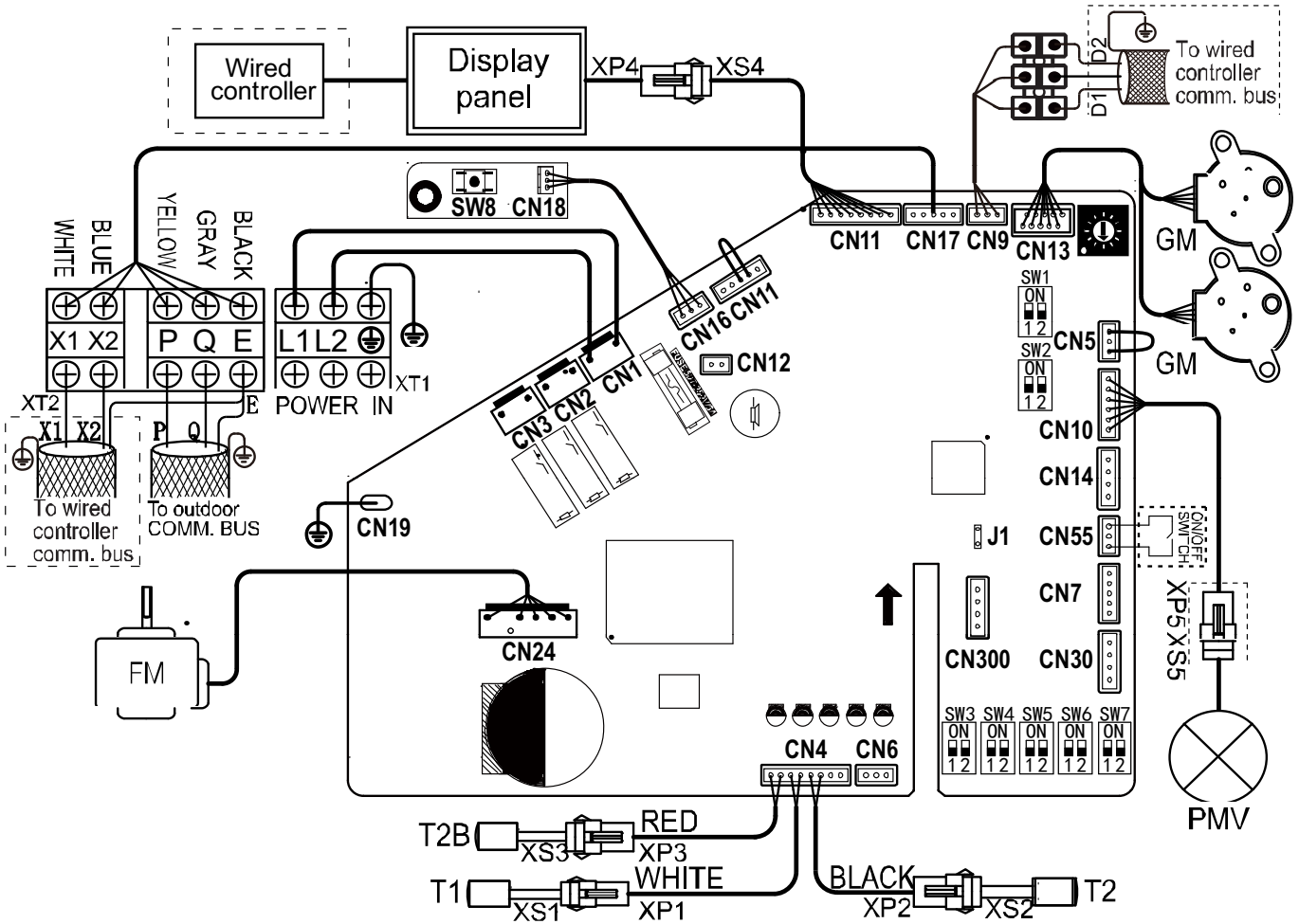

### Notes for installers and service engineers

#### Caution

- All installation, servicing and maintenance must be carried out by competent and suitably qualified, certified and accredited professionals and in accordance with all applicable legislation.
- Units should be grounded in accordance with all applicable legislation. Metal and other conductive components should be insulated in accordance with all applicable legislation.
- Power supply wiring should be securely fastened at the power supply terminals – loose power supply wiring would represent a fire risk.
- After installation, servicing or maintenance, the electric control box cover should be closed. Failing to close the electric control box cover risks fire or electric shock.
- Switch ENC1 (indoor unit capacity setting) is factory-set and its setting should normally not be changed. The only circumstances in which a switch ENC1 might need to be set in the field is when replacing a main PCB. When replacing a main PCB, ensure that the capacity setting on switch ENC1 on the new PCB is consistent with the unit capacity given on the unit's nameplate.

## 6 Capacity Tables

### 6.1 Cooling Capacity Table

Table 6.1: Wall mounted cooling capacity

Capacity (kW)	Outdoor air temperature (°C DB)	Indoor air temperature (°C WB/DB)													
		14/20		16/23		18/26		19/27		20/28		22/30		24/32	
		TC	SC	TC	SC	TC	SC	TC	SC	TC	SC	TC	SC	TC	SC
		kW	kW	kW	kW	kW	kW	kW	kW	kW	kW	kW	kW	kW	kW
2.2	10.0	1.5	1.3	1.8	1.4	2.1	1.5	2.2	1.5	2.3	1.6	2.6	1.6	2.9	1.5
	12.0	1.5	1.3	1.8	1.4	2.1	1.5	2.2	1.5	2.3	1.6	2.6	1.6	2.8	1.5
	14.0	1.5	1.3	1.8	1.4	2.1	1.5	2.2	1.5	2.3	1.6	2.6	1.6	2.8	1.5
	16.0	1.5	1.3	1.8	1.4	2.1	1.5	2.2	1.5	2.3	1.6	2.6	1.6	2.8	1.5
	18.0	1.5	1.3	1.8	1.4	2.1	1.5	2.2	1.5	2.3	1.6	2.6	1.6	2.8	1.4
	20.0	1.5	1.3	1.8	1.4	2.1	1.5	2.2	1.5	2.3	1.6	2.6	1.6	2.7	1.4
	21.0	1.5	1.3	1.8	1.4	2.1	1.5	2.2	1.5	2.3	1.6	2.6	1.6	2.7	1.4
	23.0	1.5	1.3	1.8	1.4	2.1	1.5	2.2	1.5	2.3	1.6	2.5	1.5	2.7	1.4
	25.0	1.5	1.3	1.8	1.4	2.1	1.5	2.2	1.5	2.3	1.6	2.5	1.5	2.6	1.4
	27.0	1.5	1.3	1.8	1.4	2.1	1.5	2.2	1.5	2.3	1.6	2.5	1.5	2.6	1.4
	29.0	1.5	1.3	1.8	1.4	2.1	1.5	2.2	1.5	2.3	1.6	2.4	1.4	2.5	1.4
	31.0	1.5	1.3	1.8	1.4	2.1	1.5	2.2	1.5	2.3	1.6	2.4	1.4	2.5	1.4
	33.0	1.5	1.3	1.8	1.4	2.1	1.5	2.2	1.5	2.3	1.6	2.4	1.4	2.4	1.4
	35.0	1.5	1.3	1.8	1.4	2.1	1.5	2.2	1.5	2.3	1.6	2.3	1.3	2.4	1.4
	37.0	1.5	1.3	1.8	1.4	2.1	1.5	2.2	1.5	2.3	1.6	2.3	1.3	2.3	1.4
	39.0	1.5	1.3	1.8	1.4	2.1	1.5	2.2	1.5	2.2	1.5	2.3	1.3	2.3	1.4
42.0	1.5	1.3	1.8	1.4	2.1	1.5	2.2	1.5	2.2	1.5	2.3	1.3	2.3	1.4	
44.0	1.5	1.3	1.8	1.4	2.1	1.5	2.2	1.5	2.2	1.5	2.3	1.3	2.3	1.4	
46.0	1.5	1.3	1.8	1.4	2.1	1.5	2.2	1.5	2.2	1.5	2.3	1.3	2.3	1.4	
2.8	10.0	1.9	1.6	2.3	1.8	2.6	1.9	2.8	1.9	3.0	1.9	3.3	2.0	3.7	2.0
	12.0	1.9	1.6	2.3	1.8	2.6	1.9	2.8	1.9	3.0	1.9	3.3	2.0	3.6	2.0
	14.0	1.9	1.6	2.3	1.8	2.6	1.9	2.8	1.9	3.0	1.9	3.3	2.0	3.6	2.0
	16.0	1.9	1.6	2.3	1.8	2.6	1.9	2.8	1.9	3.0	1.9	3.3	2.0	3.5	1.9
	18.0	1.9	1.6	2.3	1.8	2.6	1.9	2.8	1.9	3.0	1.9	3.3	2.0	3.5	1.9
	20.0	1.9	1.6	2.3	1.8	2.6	1.9	2.8	1.9	3.0	1.9	3.3	2.0	3.4	1.9
	21.0	1.9	1.6	2.3	1.8	2.6	1.9	2.8	1.9	3.0	1.9	3.3	2.0	3.4	1.9
	23.0	1.9	1.6	2.3	1.8	2.6	1.9	2.8	1.9	3.0	1.9	3.3	2.0	3.4	1.9
	25.0	1.9	1.6	2.3	1.8	2.6	1.9	2.8	1.9	3.0	1.9	3.2	1.9	3.3	1.9
	27.0	1.9	1.6	2.3	1.8	2.6	1.9	2.8	1.9	3.0	1.9	3.2	1.9	3.3	1.9
	29.0	1.9	1.6	2.3	1.8	2.6	1.9	2.8	1.9	3.0	1.9	3.1	1.8	3.2	1.8
	31.0	1.9	1.6	2.3	1.8	2.6	1.9	2.8	1.9	3.0	1.9	3.1	1.8	3.2	1.7
	33.0	1.9	1.6	2.3	1.8	2.6	1.9	2.8	1.9	3.0	1.9	3.1	1.8	3.1	1.7
	35.0	1.9	1.6	2.3	1.8	2.6	1.9	2.8	1.9	2.9	1.9	3.0	1.8	3.1	1.7
	37.0	1.9	1.6	2.3	1.8	2.6	1.9	2.8	1.9	2.9	1.9	3.0	1.8	3.0	1.7
	39.0	1.9	1.6	2.3	1.8	2.6	1.9	2.8	1.9	2.9	1.9	3.0	1.9	3.0	1.7
42.0	1.9	1.6	2.3	1.8	2.6	1.9	2.8	1.9	2.9	1.9	3.0	1.9	3.0	1.7	
44.0	1.9	1.6	2.3	1.8	2.6	1.9	2.8	1.9	2.9	1.9	3.0	1.9	3.0	1.7	
46.0	1.9	1.6	2.3	1.8	2.6	1.9	2.8	1.9	2.9	1.9	3.0	1.9	3.0	1.7	

Abbreviations:  
 TC: Total capacity  
 SC: Sensible capacity

Notes:  
 1. Shaded cells indicate rating condition.

Table continued on next page ...

# The 2<sup>nd</sup> Generation DC Series VRF Indoor Units

Table 6.1: Wall mounted cooling capacity (continued)

Capacity (kW)	Outdoor air temperature (°C DB)	Indoor air temperature (°C WB/DB)													
		14/20		16/23		18/26		19/27		20/28		22/30		24/32	
		TC	SC	TC	SC	TC	SC	TC	SC	TC	SC	TC	SC	TC	SC
		kW	kW	kW	kW	kW	kW	kW	kW	kW	kW	kW	kW	kW	kW
3.6	10.0	2.5	1.9	2.9	2.1	3.4	2.3	3.6	2.4	3.8	2.5	4.3	2.4	4.7	2.5
	12.0	2.5	1.9	2.9	2.1	3.4	2.3	3.6	2.4	3.8	2.5	4.3	2.4	4.7	2.5
	14.0	2.5	1.9	2.9	2.1	3.4	2.3	3.6	2.4	3.8	2.5	4.3	2.4	4.6	2.4
	16.0	2.5	1.9	2.9	2.1	3.4	2.3	3.6	2.4	3.8	2.5	4.3	2.4	4.5	2.4
	18.0	2.5	1.9	2.9	2.1	3.4	2.3	3.6	2.4	3.8	2.5	4.3	2.4	4.5	2.4
	20.0	2.5	1.9	2.9	2.1	3.4	2.3	3.6	2.4	3.8	2.5	4.3	2.4	4.4	2.3
	21.0	2.5	1.9	2.9	2.1	3.4	2.3	3.6	2.4	3.8	2.5	4.3	2.4	4.4	2.3
	23.0	2.5	1.9	2.9	2.1	3.4	2.3	3.6	2.4	3.8	2.5	4.1	2.3	4.3	2.2
	25.0	2.5	1.9	2.9	2.1	3.4	2.3	3.6	2.4	3.8	2.5	4.1	2.3	4.2	2.2
	27.0	2.5	1.9	2.9	2.1	3.4	2.3	3.6	2.4	3.8	2.5	4.0	2.2	4.2	2.2
	29.0	2.5	1.9	2.9	2.1	3.4	2.3	3.6	2.4	3.8	2.5	4.0	2.2	4.1	2.2
	31.0	2.5	1.9	2.9	2.1	3.4	2.3	3.6	2.4	3.8	2.5	4.2	2.6	4.1	2.2
	33.0	2.5	1.9	2.9	2.1	3.4	2.3	3.6	2.4	3.8	2.5	4.2	2.6	3.9	2.1
	35.0	2.5	1.9	2.9	2.1	3.4	2.3	<b>3.6</b>	2.4	3.8	2.5	4.2	2.6	3.9	2.1
	37.0	2.5	1.9	2.9	2.1	3.4	2.3	3.6	2.4	3.7	2.4	3.8	2.3	3.9	2.1
	39.0	2.5	1.9	2.9	2.1	3.4	2.3	3.6	2.4	3.7	2.4	3.8	2.3	3.8	2.1
42.0	2.5	1.9	2.9	2.1	3.4	2.3	3.6	2.4	3.7	2.4	3.8	2.3	3.8	2.1	
44.0	2.5	1.9	2.9	2.1	3.4	2.3	3.6	2.4	3.7	2.4	3.8	2.3	3.8	2.1	
46.0	2.5	1.9	2.9	2.1	3.4	2.3	3.6	2.4	3.7	2.4	3.8	2.3	3.8	2.1	
4.5	10.0	3.1	2.4	3.7	2.6	4.2	2.8	4.5	2.9	4.8	3.0	5.3	3.4	5.9	3.0
	12.0	3.1	2.4	3.7	2.6	4.2	2.8	4.5	2.9	4.8	3.0	5.3	3.4	5.9	3.0
	14.0	3.1	2.4	3.7	2.6	4.2	2.8	4.5	2.9	4.8	3.0	5.3	3.4	5.8	3.0
	16.0	3.1	2.4	3.7	2.6	4.2	2.8	4.5	2.9	4.8	3.0	5.3	3.4	5.6	2.9
	18.0	3.1	2.4	3.7	2.6	4.2	2.8	4.5	2.9	4.8	3.0	5.3	3.4	5.7	3.0
	20.0	3.1	2.4	3.7	2.6	4.2	2.8	4.5	2.9	4.8	3.0	5.3	3.4	5.7	3.0
	21.0	3.1	2.4	3.7	2.6	4.2	2.8	4.5	2.9	4.8	3.0	5.3	3.4	5.6	3.0
	23.0	3.1	2.4	3.7	2.6	4.2	2.8	4.5	2.9	4.8	3.0	5.3	3.4	5.5	3.0
	25.0	3.1	2.4	3.7	2.6	4.2	2.8	4.5	2.9	4.8	3.0	5.2	3.0	5.4	2.9
	27.0	3.1	2.4	3.7	2.6	4.2	2.8	4.5	2.9	4.8	3.0	5.1	3.0	5.2	2.8
	29.0	3.1	2.4	3.7	2.6	4.2	2.8	4.5	2.9	4.8	3.0	5.1	2.9	5.2	2.8
	31.0	3.1	2.4	3.7	2.6	4.2	2.8	4.5	2.9	4.8	3.0	5.0	2.9	5.1	2.7
	33.0	3.1	2.4	3.7	2.6	4.2	2.8	4.5	2.9	4.8	3.0	4.9	2.8	5.1	2.7
	35.0	3.1	2.4	3.7	2.6	4.2	2.8	<b>4.5</b>	2.9	4.8	3.0	4.8	2.8	5.0	2.7
	37.0	3.1	2.4	3.7	2.6	4.2	2.8	4.5	2.9	4.8	3.0	4.8	2.9	4.9	2.6
	39.0	3.1	2.4	3.7	2.6	4.2	2.8	4.5	2.9	4.6	2.8	4.7	2.8	4.8	2.6
42.0	3.1	2.4	3.7	2.6	4.2	2.8	4.5	2.9	4.6	2.8	4.7	2.8	4.8	2.6	
44.0	3.1	2.4	3.7	2.6	4.2	2.8	4.5	2.9	4.6	2.8	4.7	2.8	4.8	2.6	
46.0	3.1	2.4	3.7	2.6	4.2	2.8	4.5	2.9	4.6	2.8	4.7	3.1	4.8	2.6	

Abbreviations:

TC: Total capacity

SC: Sensible capacity

Notes:

1. Shaded cells indicate rating condition.

Table continued on next page ...

# The 2<sup>nd</sup> Generation DC Series VRF Indoor Units

Table 6.1: Wall mounted cooling capacity (continued)

Capacity (kW)	Outdoor air temperature (°C DB)	Indoor air temperature (°C WB/DB)													
		14/20		16/23		18/26		19/27		20/28		22/30		24/32	
		TC	SC	TC	SC	TC	SC	TC	SC	TC	SC	TC	SC	TC	SC
		kW	kW	kW	kW	kW	kW	kW	kW	kW	kW	kW	kW	kW	kW
5.6	10.0	3.9	2.7	4.6	3.0	5.3	3.3	5.6	3.4	5.9	3.5	6.6	3.6	7.3	3.5
	12.0	3.9	2.7	4.6	3.0	5.3	3.3	5.6	3.4	5.9	3.5	6.6	3.6	7.2	3.5
	14.0	3.9	2.7	4.6	3.0	5.3	3.3	5.6	3.4	5.9	3.5	6.6	3.6	7.1	3.5
	16.0	3.9	2.7	4.6	3.0	5.3	3.3	5.6	3.4	5.9	3.5	6.6	3.6	7.0	3.4
	18.0	3.9	2.7	4.6	3.0	5.3	3.3	5.6	3.4	5.9	3.5	6.6	3.6	6.8	3.4
	20.0	3.9	2.7	4.6	3.0	5.3	3.3	5.6	3.4	5.9	3.5	6.6	3.6	6.7	3.3
	21.0	3.9	2.7	4.6	3.0	5.3	3.3	5.6	3.4	5.9	3.5	6.6	3.6	6.6	3.3
	23.0	3.9	2.7	4.6	3.0	5.3	3.3	5.6	3.4	5.9	3.5	6.6	3.6	6.6	3.3
	25.0	3.9	2.7	4.6	3.0	5.3	3.3	5.6	3.4	5.9	3.5	6.6	3.6	6.5	3.2
	27.0	3.9	2.7	4.6	3.0	5.3	3.3	5.6	3.4	5.9	3.5	6.4	3.5	6.4	3.2
	29.0	3.9	2.7	4.6	3.0	5.3	3.3	5.6	3.4	5.9	3.5	6.3	3.5	6.4	3.3
	31.0	3.9	2.7	4.6	3.0	5.3	3.3	5.6	3.4	5.9	3.5	6.2	3.4	6.2	3.2
	33.0	3.9	2.7	4.6	3.0	5.3	3.3	5.6	3.4	5.9	3.5	6.2	3.4	6.2	3.2
	35.0	3.9	2.7	4.6	3.0	5.3	3.3	5.6	3.4	5.9	3.5	6.0	3.3	6.0	3.1
	37.0	3.9	2.7	4.6	3.0	5.3	3.3	5.6	3.4	5.9	3.5	5.9	3.2	6.0	3.1
	39.0	3.9	2.7	4.6	3.0	5.3	3.3	5.6	3.4	5.7	3.4	5.8	3.2	6.0	3.1
42.0	3.9	2.7	4.6	3.0	5.3	3.3	5.6	3.4	5.7	3.4	5.8	3.2	6.0	3.1	
44.0	3.9	2.7	4.6	3.0	5.3	3.3	5.6	3.4	5.7	3.4	5.8	3.2	6.0	3.1	
46.0	3.9	2.7	4.6	3.0	5.3	3.3	5.6	3.4	5.7	3.7	5.8	3.2	6.0	3.1	
7.1	10.0	4.9	3.6	5.8	4.0	6.7	4.3	7.1	4.5	7.5	4.4	8.4	4.5	9.2	4.6
	12.0	4.9	3.6	5.8	4.0	6.7	4.3	7.1	4.5	7.5	4.4	8.4	4.5	9.1	4.5
	14.0	4.9	3.6	5.8	4.0	6.7	4.3	7.1	4.5	7.5	4.4	8.4	4.5	9.0	4.5
	16.0	4.9	3.6	5.8	4.0	6.7	4.3	7.1	4.5	7.5	4.4	8.4	4.5	8.9	4.4
	18.0	4.9	3.6	5.8	4.0	6.7	4.3	7.1	4.5	7.5	4.4	8.4	4.5	8.7	4.3
	20.0	4.9	3.6	5.8	4.0	6.7	4.3	7.1	4.5	7.5	4.4	8.4	4.5	8.5	4.2
	21.0	4.9	3.6	5.8	4.0	6.7	4.3	7.1	4.5	7.5	4.4	8.4	4.5	8.4	4.2
	23.0	4.9	3.6	5.8	4.0	6.7	4.3	7.1	4.5	7.5	4.4	8.4	4.5	8.3	4.1
	25.0	4.9	3.6	5.8	4.0	6.7	4.3	7.1	4.5	7.5	4.4	8.4	4.5	8.2	4.1
	27.0	4.9	3.6	5.8	4.0	6.7	4.3	7.1	4.5	7.5	4.4	8.1	4.3	8.2	4.1
	29.0	4.9	3.6	5.8	4.0	6.7	4.3	7.1	4.5	7.5	4.5	8.0	4.3	8.1	4.1
	31.0	4.9	3.6	5.8	4.0	6.7	4.3	7.1	4.5	7.5	4.5	7.9	4.3	7.8	4.0
	33.0	4.9	3.6	5.8	4.0	6.7	4.3	7.1	4.5	7.5	4.5	7.8	4.2	7.8	4.0
	35.0	4.9	3.6	5.8	4.0	6.7	4.3	7.1	4.5	7.5	4.5	7.6	4.1	7.7	3.9
	37.0	4.9	3.6	5.8	4.0	6.7	4.3	7.1	4.5	7.4	4.4	7.5	4.1	7.6	4.0
	39.0	4.9	3.6	5.8	4.0	6.7	4.3	7.1	4.5	7.2	4.3	7.4	4.1	7.6	4.0
42.0	4.9	3.6	5.8	4.0	6.7	4.3	7.1	4.5	7.2	4.3	7.4	4.1	7.6	4.0	
44.0	4.9	3.6	5.8	4.0	6.7	4.3	7.1	4.5	7.2	4.3	7.4	4.1	7.6	4.0	
46.0	4.9	3.6	5.8	4.0	6.7	4.3	7.1	4.5	7.2	4.3	7.4	4.1	7.6	4.0	

Abbreviations:

TC: Total capacity

SC: Sensible capacity

Notes:

1. Shaded cells indicate rating condition.

Table continued on next page ...

# The 2<sup>nd</sup> Generation DC Series VRF Indoor Units

Table 6.1: Wall mounted cooling capacity (continued)

Capacity (kW)	Outdoor air temperature (°C DB)	Indoor air temperature (°C WB/DB)													
		14/20		16/23		18/26		19/27		20/28		22/30		24/32	
		TC	SC	TC	SC	TC	SC	TC	SC	TC	SC	TC	SC	TC	SC
		kW	kW	kW	kW	kW	kW	kW	kW	kW	kW	kW	kW	kW	kW
8.0	10.0	5.5	4.4	6.6	4.9	7.5	5.3	8.0	5.5	8.4	5.4	9.4	5.5	10.4	5.6
	12.0	5.5	4.4	6.6	4.9	7.5	5.3	8.0	5.5	8.4	5.4	9.4	5.5	10.2	5.5
	14.0	5.5	4.4	6.6	4.9	7.5	5.3	8.0	5.5	8.4	5.4	9.4	5.5	10.2	5.5
	16.0	5.5	4.4	6.6	4.9	7.5	5.3	8.0	5.5	8.4	5.4	9.4	5.5	10.0	5.4
	18.0	5.5	4.4	6.6	4.9	7.5	5.3	8.0	5.5	8.4	5.4	9.4	5.5	9.8	5.3
	20.0	5.5	4.4	6.6	4.9	7.5	5.3	8.0	5.5	8.4	5.4	9.4	5.5	9.6	5.2
	21.0	5.5	4.4	6.6	4.9	7.5	5.3	8.0	5.5	8.4	5.4	9.4	5.5	9.4	5.1
	23.0	5.5	4.4	6.6	4.9	7.5	5.3	8.0	5.5	8.4	5.4	9.4	5.5	9.4	5.1
	25.0	5.5	4.4	6.6	4.9	7.5	5.3	8.0	5.5	8.4	5.4	9.4	5.5	9.3	5.0
	27.0	5.5	4.4	6.6	4.9	7.5	5.3	8.0	5.5	8.4	5.4	9.1	5.3	9.2	5.1
	29.0	5.5	4.4	6.6	4.9	7.5	5.3	8.0	5.5	8.4	5.5	9.0	5.3	9.1	5.0
	31.0	5.5	4.4	6.6	4.9	7.5	5.3	8.0	5.5	8.4	5.5	8.9	5.2	8.8	4.8
	33.0	5.5	4.4	6.6	4.9	7.5	5.3	8.0	5.5	8.4	5.5	8.8	5.2	8.8	4.8
	35.0	5.5	4.4	6.6	4.9	7.5	5.3	8.0	5.5	8.4	5.5	8.6	5.1	8.6	4.8
	37.0	5.5	4.4	6.6	4.9	7.5	5.3	8.0	5.5	8.3	5.4	8.4	5.0	8.6	4.9
	39.0	5.5	4.4	6.6	4.9	7.5	5.3	8.0	5.5	8.1	5.3	8.3	5.0	8.6	4.9
	42.0	5.5	4.4	6.6	4.9	7.5	5.3	8.0	5.5	8.1	5.3	8.3	5.0	8.6	4.9
44.0	5.5	4.4	6.6	4.9	7.5	5.3	8.0	5.5	8.1	5.3	8.3	5.0	8.6	4.9	
46.0	5.5	4.4	6.6	4.9	7.5	5.3	8.0	5.5	8.1	5.3	8.3	5.0	8.6	4.9	
9.0	10.0	6.2	4.9	7.3	5.3	8.4	5.8	9.0	5.9	9.6	6.0	10.6	6.1	11.7	6.0
	12.0	6.2	4.9	7.3	5.3	8.4	5.8	9.0	5.9	9.6	6.0	10.6	6.1	11.5	5.9
	14.0	6.2	4.9	7.3	5.3	8.4	5.8	9.0	5.9	9.6	6.0	10.6	6.1	11.4	5.9
	16.0	6.2	4.9	7.3	5.3	8.4	5.8	9.0	5.9	9.6	6.0	10.6	6.1	11.3	5.8
	18.0	6.2	4.9	7.3	5.3	8.4	5.8	9.0	5.9	9.6	6.0	10.6	6.1	11.0	5.8
	20.0	6.2	4.9	7.3	5.3	8.4	5.8	9.0	5.9	9.6	6.0	10.6	6.1	10.8	5.7
	21.0	6.2	4.9	7.3	5.3	8.4	5.8	9.0	5.9	9.6	6.0	10.6	6.1	10.6	5.6
	23.0	6.2	4.9	7.3	5.3	8.4	5.8	9.0	5.9	9.6	6.0	10.6	6.1	10.5	5.5
	25.0	6.2	4.9	7.3	5.3	8.4	5.8	9.0	5.9	9.6	6.0	10.6	6.1	10.4	5.5
	27.0	6.2	4.9	7.3	5.3	8.4	5.8	9.0	5.9	9.6	6.0	10.3	5.9	10.4	5.4
	29.0	6.2	4.9	7.3	5.3	8.4	5.8	9.0	5.9	9.6	6.0	10.1	5.7	10.3	5.4
	31.0	6.2	4.9	7.3	5.3	8.4	5.8	9.0	5.9	9.6	6.0	10.0	5.7	9.9	5.3
	33.0	6.2	4.9	7.3	5.3	8.4	5.8	9.0	5.9	9.6	6.0	9.9	5.6	9.9	5.3
	35.0	6.2	4.9	7.3	5.3	8.4	5.8	9.0	5.9	9.5	6.0	9.6	5.5	9.7	5.3
	37.0	6.2	4.9	7.3	5.3	8.4	5.8	9.0	5.9	9.3	5.8	9.5	5.4	9.6	5.3
	39.0	6.2	4.9	7.3	5.3	8.4	5.8	9.0	5.9	9.2	5.7	9.4	5.3	9.6	5.3
	42.0	6.2	4.9	7.3	5.3	8.4	5.8	9.0	5.9	9.2	5.7	9.4	5.3	9.6	5.3
44.0	6.2	4.9	7.3	5.3	8.4	5.8	9.0	5.9	9.2	5.7	9.4	5.3	9.6	5.3	
46.0	6.2	4.9	7.3	5.3	8.4	5.8	9.0	5.9	9.2	5.7	9.4	5.3	9.6	5.3	

Abbreviations:

TC: Total capacity

SC: Sensible capacity

Notes:

1. Shaded cells indicate rating condition.

# The 2<sup>nd</sup> Generation DC Series VRF Indoor Units

## 6.2 Heating Capacity Table

Table 6.2: Wall mounted heating capacity

Capacity (kW)	Outdoor air temperature (°C)		Indoor air temperature (°C DB)					
			16	18	20	21	22	24
	WB	DB	TC	TC	TC	TC	TC	TC
2.2	-20	-19.8	1.34	1.34	1.34	1.34	1.34	1.34
	-19	-18.8	1.44	1.44	1.44	1.44	1.44	1.44
	-17	-16.7	1.51	1.51	1.51	1.51	1.51	1.51
	-15	-14.7	1.56	1.56	1.56	1.56	1.56	1.56
	-13.00	-12.60	1.66	1.66	1.66	1.66	1.66	1.66
	-11.00	-10.50	1.68	1.70	1.70	1.70	1.70	1.70
	-10.00	-9.50	1.75	1.75	1.75	1.75	1.75	1.75
	-9.10	-8.50	1.80	1.80	1.80	1.80	1.80	1.80
	-7.60	-7.00	1.82	1.82	1.82	1.82	1.82	1.82
	-5.60	-5.00	1.90	1.90	1.90	1.90	1.90	1.90
	-3.70	-3.00	1.99	1.99	1.99	1.99	1.99	1.99
	-0.70	0.00	2.14	2.14	2.14	2.14	2.14	2.02
	2.20	3.00	2.26	2.26	2.26	2.26	2.21	2.02
	4.10	5.00	2.33	2.33	2.33	2.33	2.21	2.02
	6.00	7.00	2.40	2.40	2.40	2.33	2.21	2.02
	7.90	9.00	2.47	2.47	2.40	2.33	2.21	2.02
9.80	11.00	2.54	2.54	2.40	2.33	2.21	2.02	
11.80	13.00	2.64	2.59	2.40	2.33	2.21	2.02	
13.70	15.00	2.71	2.59	2.40	2.33	2.21	2.02	
2.8	-20	-19.8	1.79	1.79	1.79	1.79	1.79	1.79
	-19	-18.8	1.92	1.92	1.92	1.92	1.92	1.92
	-17	-16.7	2.02	2.02	2.02	2.02	2.02	2.02
	-15	-14.7	2.02	2.02	2.02	2.02	2.02	2.02
	-13.00	-12.60	2.14	2.14	2.14	2.14	2.14	2.14
	-11.00	-10.50	2.24	2.24	2.24	2.24	2.24	2.24
	-10.00	-9.50	2.34	2.34	2.34	2.34	2.34	2.34
	-9.10	-8.50	2.40	2.40	2.40	2.40	2.40	2.40
	-7.60	-7.00	2.43	2.43	2.43	2.43	2.43	2.43
	-5.60	-5.00	2.53	2.53	2.53	2.53	2.53	2.53
	-3.70	-3.00	2.66	2.66	2.66	2.66	2.66	2.66
	-0.70	0.00	2.85	2.85	2.85	2.85	2.85	2.69
	2.20	3.00	3.01	3.01	3.01	3.01	2.94	2.69
	4.10	5.00	3.10	3.10	3.10	3.10	2.94	2.69
	6.00	7.00	3.20	3.20	3.20	3.10	2.94	2.69
	7.90	9.00	3.30	3.30	3.20	3.10	2.94	2.69
9.80	11.00	3.39	3.39	3.20	3.10	2.94	2.69	
11.80	13.00	3.52	3.46	3.20	3.10	2.94	2.69	
13.70	15.00	3.62	3.46	3.20	3.10	2.94	2.69	

Abbreviations:  
TC: Total capacity

Notes:  
1. Shaded cells indicate rating condition.

Table continued on next page ...



# The 2<sup>nd</sup> Generation DC Series VRF Indoor Units

Table 6.2: Wall mounted heating capacity (continued)

Capacity (kW)	Outdoor air temperature (°C)		Indoor air temperature (°C DB)					
			16	18	20	21	22	24
	WB	DB	TC	TC	TC	TC	TC	TC
3.6	-20	-19.8	2.24	2.24	2.24	2.24	2.24	2.24
	-19	-18.8	2.40	2.40	2.40	2.40	2.40	2.40
	-17	-16.7	2.52	2.52	2.52	2.52	2.52	2.52
	-15	-14.7	2.60	2.60	2.60	2.60	2.60	2.60
	-13.00	-12.60	2.68	2.68	2.68	2.68	2.68	2.68
	-11.00	-10.50	2.80	2.80	2.80	2.80	2.80	2.80
	-10.00	-9.50	2.92	2.92	2.92	2.92	2.92	2.92
	-9.10	-8.50	3.00	3.00	3.00	3.00	3.00	3.00
	-7.60	-7.00	3.04	3.04	3.04	3.04	3.04	3.04
	-5.60	-5.00	3.16	3.16	3.16	3.16	3.16	3.16
	-3.70	-3.00	3.32	3.32	3.32	3.32	3.32	3.32
	-0.70	0.00	3.56	3.56	3.56	3.56	3.56	3.36
	2.20	3.00	3.76	3.76	3.76	3.76	3.68	3.36
	4.10	5.00	3.88	3.88	3.88	3.88	3.68	3.36
	6.00	7.00	4.00	4.00	4.00	3.88	3.68	3.36
	7.90	9.00	4.12	4.12	4.00	3.88	3.68	3.36
	9.80	11.00	4.24	4.24	4.00	3.88	3.68	3.36
11.80	13.00	4.40	4.32	4.00	3.88	3.68	3.36	
13.70	15.00	4.52	4.32	4.00	3.88	3.68	3.36	
4.5	-20	-19.8	2.80	2.80	2.80	2.80	2.80	2.80
	-19	-18.8	3.00	3.00	3.00	3.00	3.00	3.00
	-17	-16.7	3.15	3.15	3.15	3.15	3.15	3.15
	-15	-14.7	3.25	3.25	3.25	3.25	3.25	3.25
	-13.00	-12.60	3.35	3.35	3.35	3.35	3.35	3.35
	-11.00	-10.50	3.50	3.50	3.50	3.50	3.50	3.50
	-10.00	-9.50	3.65	3.65	3.65	3.65	3.65	3.65
	-9.10	-8.50	3.75	3.75	3.75	3.75	3.75	3.75
	-7.60	-7.00	3.80	3.80	3.80	3.80	3.80	3.80
	-5.60	-5.00	3.95	3.95	3.95	3.95	3.95	3.95
	-3.70	-3.00	4.15	4.15	4.15	4.15	4.15	4.15
	-0.70	0.00	4.45	4.45	4.45	4.45	4.45	4.20
	2.20	3.00	4.70	4.70	4.70	4.70	4.60	4.20
	4.10	5.00	4.85	4.85	4.85	4.85	4.60	4.20
	6.00	7.00	5.00	5.00	5.00	4.85	4.60	4.20
	7.90	9.00	5.15	5.15	5.00	4.85	4.60	4.20
	9.80	11.00	5.30	5.30	5.00	4.85	4.60	4.20
11.80	13.00	5.50	5.40	5.00	4.85	4.60	4.20	
13.70	15.00	5.65	5.40	5.00	4.85	4.60	4.20	

Abbreviations:  
TC: Total capacity

Notes:  
1. Shaded cells indicate rating condition.

Table continued on next page ...

# The 2<sup>nd</sup> Generation DC Series VRF Indoor Units

Table 6.2: Wall mounted heating capacity (continued)

Capacity (kW)	Outdoor air temperature (°C)		Indoor air temperature (°C DB)					
			16	18	20	21	22	24
	WB	DB	TC kW	TC kW	TC kW	TC kW	TC kW	TC kW
5.6	-20	-19.8	3.53	3.53	3.53	3.53	3.53	3.53
	-19	-18.8	3.78	3.78	3.78	3.78	3.78	3.78
	-17	-16.7	3.97	3.97	3.97	3.97	3.97	3.97
	-15	-14.7	4.10	4.10	4.10	4.10	4.10	4.10
	-13.00	-12.60	4.22	4.22	4.22	4.22	4.22	4.22
	-11.00	-10.50	4.41	4.41	4.41	4.41	4.41	4.41
	-10.00	-9.50	4.60	4.60	4.60	4.60	4.60	4.60
	-9.10	-8.50	4.73	4.73	4.73	4.73	4.73	4.73
	-7.60	-7.00	4.79	4.79	4.79	4.79	4.79	4.79
	-5.60	-5.00	4.98	4.98	4.98	4.98	4.98	4.98
	-3.70	-3.00	5.23	5.23	5.23	5.23	5.23	5.23
	-0.70	0.00	5.61	5.61	5.61	5.61	5.61	5.29
	2.20	3.00	5.92	5.92	5.92	5.92	5.80	5.29
	4.10	5.00	6.11	6.11	6.11	6.11	5.80	5.29
	6.00	7.00	6.30	6.30	<b>6.30</b>	6.11	5.80	5.29
	7.90	9.00	6.49	6.49	6.30	6.11	5.80	5.29
9.80	11.00	6.68	6.68	6.30	6.11	5.80	5.29	
11.80	13.00	6.93	6.80	6.30	6.11	5.80	5.29	
13.70	15.00	7.12	6.80	6.30	6.11	5.80	5.29	
7.1	-20	-19.8	4.48	4.48	4.48	4.48	4.48	4.48
	-19	-18.8	4.80	4.80	4.80	4.80	4.80	4.80
	-17	-16.7	5.04	5.04	5.04	5.04	5.04	5.04
	-15	-14.7	5.20	5.20	5.20	5.20	5.20	5.20
	-13.00	-12.60	5.36	5.36	5.36	5.36	5.36	5.36
	-11.00	-10.50	5.60	5.60	5.60	5.60	5.60	5.60
	-10.00	-9.50	5.84	5.84	5.84	5.84	5.84	5.84
	-9.10	-8.50	6.00	6.00	6.00	6.00	6.00	6.00
	-7.60	-7.00	6.08	6.08	6.08	6.08	6.08	6.08
	-5.60	-5.00	6.32	6.32	6.32	6.32	6.32	6.32
	-3.70	-3.00	6.64	6.64	6.64	6.64	6.64	6.64
	-0.70	0.00	7.12	7.12	7.12	7.12	7.12	6.72
	2.20	3.00	7.52	7.52	7.52	7.52	7.36	6.72
	4.10	5.00	7.76	7.76	7.76	7.76	7.36	6.72
	6.00	7.00	8.00	8.00	<b>8.00</b>	7.76	7.36	6.72
	7.90	9.00	8.24	8.24	8.00	7.76	7.36	6.72
9.80	11.00	8.48	8.48	8.00	7.76	7.36	6.72	
11.80	13.00	8.80	8.64	8.00	7.76	7.36	6.72	
13.70	15.00	9.04	8.64	8.00	7.76	7.36	6.72	

Abbreviations:  
TC: Total capacity

Notes:  
1. Shaded cells indicate rating condition.

Table continued on next page ...

# The 2<sup>nd</sup> Generation DC Series VRF Indoor Units

Table 6.2: Wall mounted heating capacity (continued)

Capacity (kW)	Outdoor air temperature (°C)		Indoor air temperature (°C DB)					
			16	18	20	21	22	24
	WB	DB	TC	TC	TC	TC	TC	TC
8.0	-20	-19.8	5.04	5.04	5.04	5.04	5.04	5.04
	-19	-18.8	5.40	5.40	5.40	5.40	5.40	5.40
	-17	-16.7	5.67	5.67	5.67	5.67	5.67	5.67
	-15	-14.7	5.85	5.85	5.85	5.85	5.85	5.85
	-13.00	-12.60	6.03	6.03	6.03	6.03	6.03	6.03
	-11.00	-10.50	6.30	6.30	6.30	6.30	6.30	6.30
	-10.00	-9.50	6.57	6.57	6.57	6.57	6.57	6.57
	-9.10	-8.50	6.75	6.75	6.75	6.75	6.75	6.75
	-7.60	-7.00	6.84	6.84	6.84	6.84	6.84	6.84
	-5.60	-5.00	7.11	7.11	7.11	7.11	7.11	7.11
	-3.70	-3.00	7.47	7.47	7.47	7.47	7.47	7.47
	-0.70	0.00	8.01	8.01	8.01	8.01	8.01	7.56
	2.20	3.00	8.46	8.46	8.46	8.46	8.28	7.56
	4.10	5.00	8.73	8.73	8.73	8.73	8.28	7.56
	6.00	7.00	9.00	9.00	9.00	8.73	8.28	7.56
	7.90	9.00	9.27	9.27	9.00	8.73	8.28	7.56
	9.80	11.00	9.54	9.54	9.00	8.73	8.28	7.56
11.80	13.00	9.90	9.72	9.00	8.73	8.28	7.56	
13.70	15.00	10.17	9.72	9.00	8.73	8.28	7.56	
9.0	-20	-19.8	5.60	5.04	5.60	5.60	5.60	5.60
	-19	-18.8	6.00	5.40	6.00	6.00	6.00	6.00
	-17	-16.7	6.30	6.30	6.30	6.30	6.30	6.30
	-15	-14.7	6.50	6.50	6.50	6.50	6.50	6.50
	-13.00	-12.60	6.70	6.70	6.70	6.70	6.70	6.70
	-11.00	-10.50	7.00	7.00	7.00	7.00	7.00	7.00
	-10.00	-9.50	7.30	7.30	7.30	7.30	7.30	7.30
	-9.10	-8.50	7.50	7.50	7.50	7.50	7.50	7.50
	-7.60	-7.00	7.60	7.60	7.60	7.60	7.60	7.60
	-5.60	-5.00	7.90	7.90	7.90	7.90	7.90	7.90
	-3.70	-3.00	8.30	8.30	8.30	8.30	8.30	8.30
	-0.70	0.00	8.90	8.90	8.90	8.90	8.90	8.40
	2.20	3.00	9.40	9.40	9.40	9.40	9.20	8.40
	4.10	5.00	9.70	9.70	9.70	9.70	9.20	8.40
	6.00	7.00	10.00	10.00	10.00	9.70	9.20	8.40
	7.90	9.00	10.30	10.30	10.00	9.70	9.20	8.40
	9.80	11.00	10.60	10.60	10.00	9.70	9.20	8.40
11.80	13.00	11.00	10.80	10.00	9.70	9.20	8.40	
13.70	15.00	11.30	10.80	10.00	9.70	9.20	8.40	

Abbreviations:  
TC: Total capacity

Notes:  
1. Shaded cells indicate rating condition.

## 7 Electrical Characteristics

Table 7.1: Wall mounted electrical characteristics

Model	Power supply						Indoor fan motors	
	Hz	Volts	Min. volts	Max. volts	MCA	MFA	Rated motor output (kW)	FLA
MVD-22GDN1	50	220-240	198	264	0.32	15	0.02	0.25
MVD-28GDN1	50	220-240	198	264	0.32	15	0.02	0.25
MVD-36GDN1	50	220-240	198	264	0.45	15	0.058	0.36
MVD-45GDN1	50	220-240	198	264	0.47	15	0.058	0.37
MVD-56GDN1	50	220-240	198	264	0.58	15	0.058	0.46
MVD-71GDN1	50	220-240	198	264	0.90	15	0.06	0.72
MVD-80GDN1	50	220-240	198	264	0.90	15	0.06	0.72
MVD-90GDN1	50	220-240	198	264	1.10	15	0.06	0.88

Abbreviations:

MCA: Minimum Circuit Amps

MFA: Maximum Fuse Amps

FLA: Full Load Amps

# The 2<sup>nd</sup> Generation DC Series VRF Indoor Units

## 8 Sound Levels

### 8.1 Overall

Table 8.1: Wall mounted sound pressure levels<sup>1</sup>

Model name	Sound pressure levels dB(A)						
	SSH	SH	H	M	L	SL	SSL
MVD-22GDN1	31	30	30	30	29	29	29
MVD-28GDN1	31	30	30	30	29	29	29
MVD-36GDN1	33	32	32	31	31	30	30
MVD-45GDN1	35	34	33	33	32	31	31
MVD-56GDN1	38	37	36	36	35	34	34
MVD-71GDN1	44	43	42	39	38	37	36
MVD-80GDN1	44	43	42	39	38	37	36
MVD-90GDN1	48	46	45	43	41	40	38

Notes:

1. Sound pressure levels are measured in a semi-anechoic chamber. During in-situ operation, sound pressure levels may be higher as a result of ambient noise.

Figure 8.1: Wall mounted sound pressure level measurement

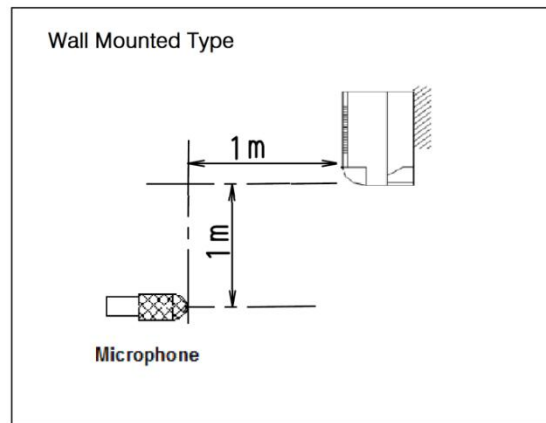

### 8.2 Octave Band Levels

Figure 8.2: MVD-22(28)GDN1 octave band levels

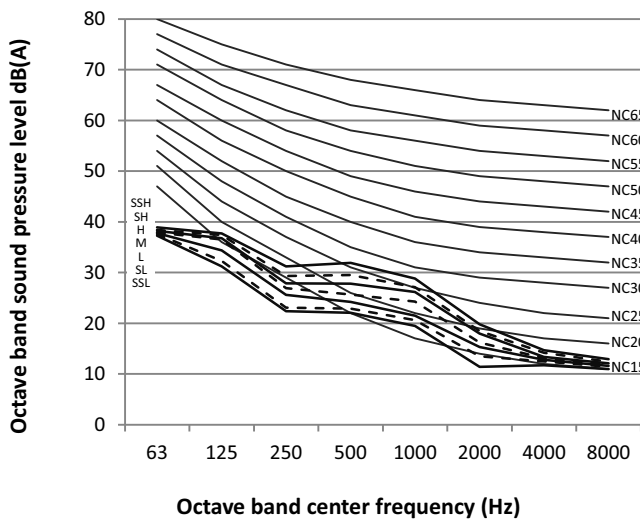
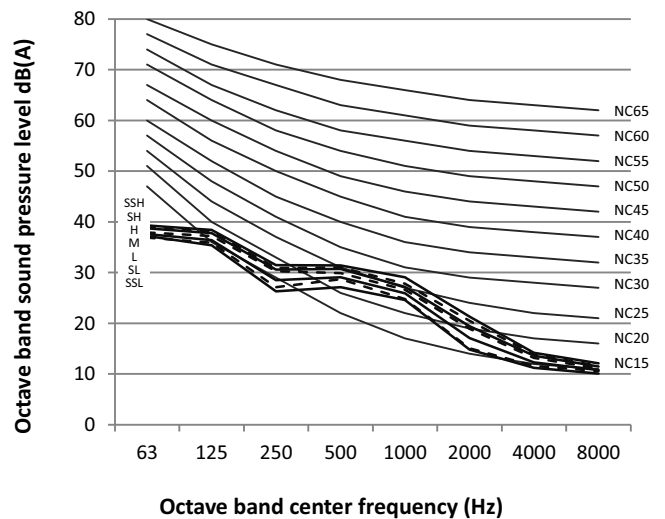

Figure 8.3: MVD-36GDN1 octave band levels



# The 2<sup>nd</sup> Generation DC Series VRF Indoor Units

Figure 8.4: MVD-45GDN1 octave band levels

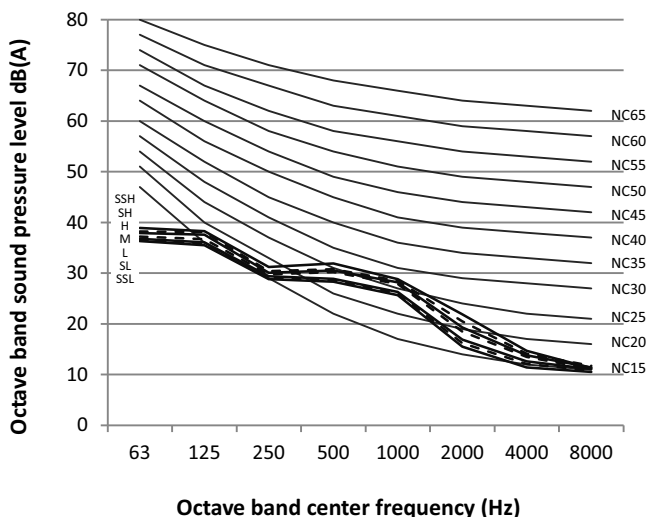

Figure 8.5: MVD-56GDN1 octave band levels

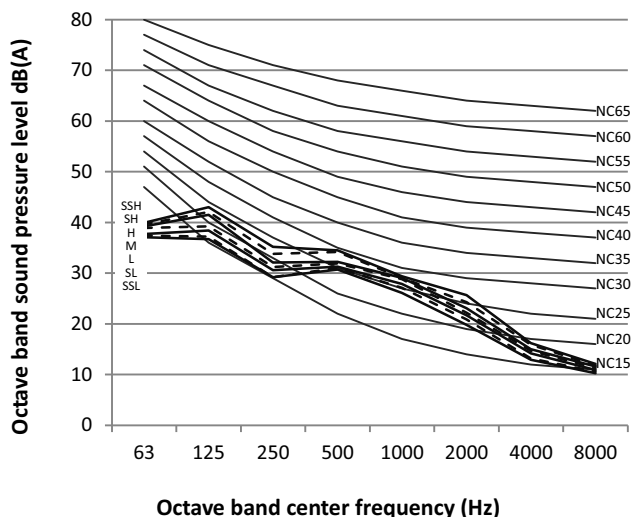

Figure 8.6: MVD-71(80)GDN1 octave band levels

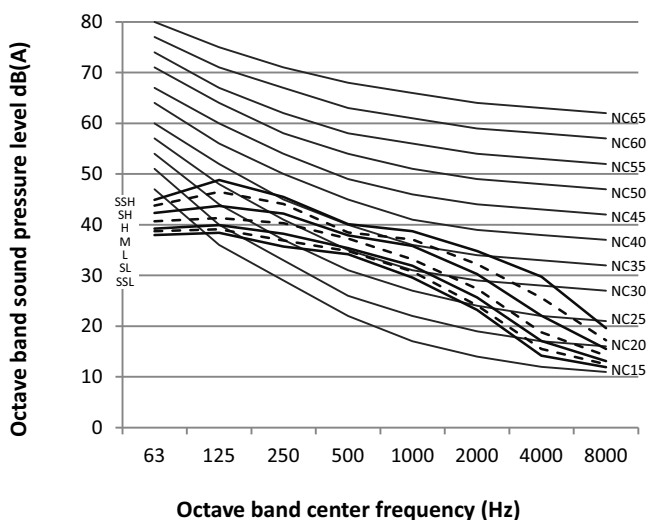
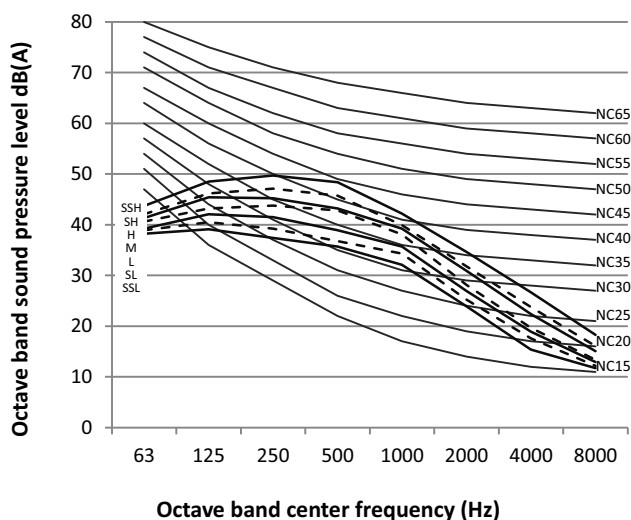

Figure 8.7: MVD-90GDN1 octave band levels



# The 2<sup>nd</sup> Generation DC Series VRF Indoor Units

## 9 Error codes

With the exception of a mode conflict error, contact your supplier or service engineer if any of the error codes listed in the following table are displayed on the unit's display panel. If the mode conflict error is displayed and persists, contact your supplier or service engineer. These errors should only be investigated by a professional technician. The descriptions are provided in this manual for reference only.

Content	Digital display output	Possible causes
Mode conflict	E0	<ul style="list-style-type: none"> <li>♦ The indoor unit's operating mode conflicts with that of the outdoor units.</li> </ul>
Communication error between indoor and outdoor units	E1	<ul style="list-style-type: none"> <li>♦ Communication wires between indoor and outdoor units not connected properly.</li> <li>♦ Interference from high voltage wires or other sources of electromagnetic radiation.</li> <li>♦ Communication wire too long.</li> <li>♦ Damaged main PCB.</li> </ul>
Indoor ambient temperature sensor (T1) error	E2	<ul style="list-style-type: none"> <li>♦ Temperature sensor not connected properly or has malfunctioned.</li> <li>♦ Damaged main PCB.</li> </ul>
Indoor heat exchanger mid-point temperature sensor (T2) error	E3	
Indoor heat exchanger outlet temperature sensor (T2B) error	E4	
Fan error	E6	<ul style="list-style-type: none"> <li>♦ Fan stuck or blocked.</li> <li>♦ Fan motor not connected properly or has malfunctioned.</li> <li>♦ Power supply abnormal.</li> <li>♦ Damaged main PCB.</li> </ul>
EEPROM mismatch	E7	<ul style="list-style-type: none"> <li>♦ Damaged main PCB.</li> </ul>
EEV error	Eb	<ul style="list-style-type: none"> <li>♦ Line loosened or broken.</li> <li>♦ The electronic expansion valve is stuck.</li> <li>♦ Damaged main PCB.</li> </ul>
Outdoor unit error	Ed	<ul style="list-style-type: none"> <li>♦ Outdoor unit error.</li> </ul>
Water level error	EE	<ul style="list-style-type: none"> <li>♦ Water level float stuck.</li> <li>♦ Water level switch not connected properly.</li> <li>♦ Damaged main PCB.</li> <li>♦ Drain pump has malfunctioned.</li> </ul>
The indoor unit has not been assigned an address	FE	<ul style="list-style-type: none"> <li>♦ Indoor unit has not been assigned an address.</li> </ul>

Notes:

Flashing rapidly means flashing twice per second; flashing slowly means flashing once per second.



MUNDO  CLIMA<sup>®</sup>



[www.mundoclima.com](http://www.mundoclima.com)

**ASK FOR MORE INFORMATION**

Phone: (+34) 93 446 27 80

eMail: [info@mundoclima.com](mailto:info@mundoclima.com)

**TECHNICAL ASSISTANCE**

Phone: (+34) 93 652 53 57