

# Cassette 4 Vías

## Service manual



# Four-way Cassette

<b>1 Specifications .....</b>	<b>4</b>
<b>2 Dimensions .....</b>	<b>7</b>
<b>3 Unit Placement .....</b>	<b>8</b>
<b>4 Piping Diagram .....</b>	<b>10</b>
<b>5 Wiring Diagram .....</b>	<b>11</b>
<b>6 Capacity Tables.....</b>	<b>14</b>
<b>7 Electrical Characteristics.....</b>	<b>20</b>
<b>8 Sound Levels .....</b>	<b>21</b>
<b>9 Error codes.....</b>	<b>23</b>

# The 2<sup>nd</sup> Generation DC Series VRF Indoor Units

## 1 Specifications

Table 1.1: MVD-56(71, 80)Q4DN1 specifications

Model			MVD-56Q4DN1	MVD-71Q4DN1	MVD-80Q4DN1
Power supply			1 phase, 220-240V, 50Hz		
Cooling <sup>1</sup>	Capacity	kW	5.6	7.1	8.0
		kBtu/h	19.1	24.2	27.3
	Power input	W	60	70	96
Heating <sup>2</sup>	Capacity	kW	6.3	8.0	9.0
		kBtu/h	21.5	27.3	30.7
	Power input	W	60	70	96
Fan motor	Model		ZKSP-80-8-2		
	Type		DC motor		
	Brand		Nidec/Welling /Yongan		
	Speed <sup>3</sup>	r/min	450/440/410/380 /370/360/330	490/470/440/410 /400/380/350	590/560/530/490 /460/430/400
Indoor coil	Number of rows		2		
	Tube pitch × row pitch	mm	21×13.37		
	Fin spacing	mm	1.5		
	Fin type		Hydrophilic aluminum		
	Tube OD and type	mm	Φ7 Inner-groove		
	Dimensions (L×H×W)	mm	1961×168		
	Number of circuits		8		
Air flow rate <sup>3</sup>		m <sup>3</sup> /h	893/866/804/744/714 /698/635	977/937/864/800/778 /738/671	1203/1131/1064/977 /912/840/774
Sound pressure level <sup>4</sup>		dB(A)	35/34/31/31/30/28/26	35/35/34/31/30/28/27	36/35/34/31/31/29/28
Sound power level		dB(A)	50/49/47/47/45/42/40	50/49/47/47/45/42/41	52/49/48/46/46/42/42
Main body	Net dimensions <sup>5</sup> (W×H×D)		mm 840×230×840		
	Packed dimensions (W×H×D)		mm 955×260×955		
	Net/Gross weight		kg 23.2/27.6		
Panel	Net dimensions (W×H×D)		mm 950×54.5×950		
	Packed dimensions (W×H×D)		mm 1035×90×1035		
	Net/Gross weight		kg 5/8		
Refrigerant type			R410A		
Throttle	Type		Electronic expansion valve		
	Model		D20MISZ-1R(L)		
Design pressure (H/L)		MPa	4.4/2.6		
Pipe connections	Liquid/Gas pipe		mm Φ9.53/Φ15.9		
	Drain pipe		mm OD Φ32		

Notes:

- Indoor temperature 27°C DB, 19°C WB; outdoor temperature 35°C DB; equivalent refrigerant piping length 7.5m with zero level difference.
- Indoor temperature 20°C DB; outdoor temperature 7°C DB, 6°C WB; equivalent refrigerant piping length 7.5m with zero level difference.
- Fan motor speed and air flow rate are from the highest speed to the lowest speed, total 7 rates for each model.
- Sound pressure level is from highest level to lowest level, total 7 levels for each model. Sound pressure level is measured 1.4m below the unit in a semi-anechoic chamber.
- Unit body dimensions given are the largest external dimensions of the unit, including hanger attachments.

# The 2<sup>nd</sup> Generation DC Series VRF Indoor Units

Table 1.2: MVD-90(100)Q4DN1 specifications

Model			MVD-90Q4DN1
Power supply			1 phase, 220-240V, 50Hz
Cooling <sup>1</sup>	Capacity	kW	9.0
		kBtu/h	30.7
	Power input	W	100
Heating <sup>2</sup>	Capacity	kW	10.0
		kBtu/h	34.1
	Power input	W	100
Fan motor	Model		ZKSP-170-8-6
	Type		DC motor
	Brand		Nidec/Welling /Yongan
	Speed <sup>3</sup>	r/min	490/470/450/440/410/380/360
Indoor coil	Number of rows		2
	Tube pitch × row pitch	mm	21×13.37
	Fin spacing	mm	1.5
	Fin type		Hydrophilic aluminum
	Tube OD and type	mm	Φ7 Inner-groove
	Dimensions (L×H×W)	mm	1955×252
	Number of circuits		8
Air flow rate <sup>3</sup>		m <sup>3</sup> /h	1349/1294/1230/1201/1111/1029 /970
Sound pressure level <sup>4</sup>		dB(A)	37/35/34/31/31/30/28
Sound power level		dB(A)	53/49/48/46/46/44/43
Main body	Net dimensions <sup>5</sup> (W×H×D)		mm 840×300×840
	Packed dimensions (W×H×D)		mm 955×330×955
	Net/Gross weight		kg 28.4/33.8
Panel	Net dimensions (W×H×D)		mm 950×54.5×950
	Packed dimensions (W×H×D)		mm 1035×90×1035
	Net/Gross weight		kg 5/8
Refrigerant type			R410A
Throttle	Type	Electronic expansion valve	
	Model	D20MISZ-1R(L)	
Design pressure (H/L)		MPa	4.4/2.6
Pipe connections	Liquid/Gas pipe	mm	Φ9.53/Φ15.9
	Drain pipe	mm	OD Φ32

Notes:

1. Indoor temperature 27°C DB, 19°C WB; outdoor temperature 35°C DB; equivalent refrigerant piping length 7.5m with zero level difference.
2. Indoor temperature 20°C DB; outdoor temperature 7°C DB, 6°C WB; equivalent refrigerant piping length 7.5m with zero level difference.
3. Fan motor speed and air flow rate are from the highest speed to the lowest speed, total 7 rates for each model.
4. Sound pressure level is from highest level to lowest level, total 7 levels for each model. Sound pressure level is measured 1.4m below the unit in a semi-anechoic chamber.
5. Unit body dimensions given are the largest external dimensions of the unit, including hanger attachments.

# The 2<sup>nd</sup> Generation DC Series VRF Indoor Units

Table 1.4: MVD-112(140)Q4DN1 specifications

Model			MVD-112Q4DN1	MVD-140Q4DN1
Power supply			1 phase, 220-240V, 50Hz	
Cooling <sup>1</sup>	Capacity	kW	11.2	14.0
		kBtu/h	38.2	47.8
	Power input	W	160	170
Heating <sup>2</sup>	Capacity	kW	12.5	16.0
		kBtu/h	42.7	54.6
	Power input	W	160	170
Fan motor	Model		ZKSP-170-8-6	
	Type		DC motor	
	Brand		Nidec/Welling /Yongan	
	Speed <sup>3</sup>	r/min	590/560/520/480/450/435/420	620/590/550/510/480/465/450
Indoor coil	Number of rows		2	3
	Tube pitch × row pitch	mm	21×13.37	
	Fin spacing	mm	1.5	
	Fin type		Hydrophilic aluminum	
	Tube OD and type	mm	Φ7 Inner-groove	
	Dimensions (L×H×W)	mm	1955×252	
	Number of circuits		8	
Air flow rate <sup>3</sup>		m <sup>3</sup> /h	1641/1544/1431/1309/1225/1198/1143	1662/1574/1448/1348/1253/1219/1170
Sound pressure level <sup>4</sup>		dB(A)	38/36/35/34/31/31/30	39/37/36/35/34/31/31
Sound power level		dB(A)	55/52/49/48/46/46/44	56/55/52/49/48/46/46
Main body	Net dimensions <sup>5</sup> (W×H×D)		840×300×840	
	Packed dimensions (W×H×D)		955×330×955	
	Net/Gross weight		28.4/33.8	30.7/35.8
Panel	Net dimensions (W×H×D)		950×54.5×950	
	Packed dimensions (W×H×D)		1035×90×1035	
	Net/Gross weight		5/8	
Refrigerant type			R410A	
Throttle	Type		Electronic expansion valve	
	Model		D20MISZ-1R(L)	BD24FKS(L)
Design pressure (H/L)		MPa	4.4/2.6	
Pipe	Liquid/Gas pipe	mm	Φ9.53/Φ15.9	
connections	Drain pipe	mm	OD Φ32	

Notes:

- Indoor temperature 27°C DB, 19°C WB; outdoor temperature 35°C DB; equivalent refrigerant piping length 7.5m with zero level difference.
- Indoor temperature 20°C DB; outdoor temperature 7°C DB, 6°C WB; equivalent refrigerant piping length 7.5m with zero level difference.
- Fan motor speed and air flow rate are from the highest speed to the lowest speed, total 7 rates for each model.
- Sound pressure level is from highest level to lowest level, total 7 levels for each model. Sound pressure level is measured 1.4m below the unit in a semi-anechoic chamber.
- Unit body dimensions given are the largest external dimensions of the unit, including hanger attachments.

## 2 Dimensions

### 2.1 Unit Dimensions

Figure 2.1: Four-way Cassette dimensions (unit: mm)

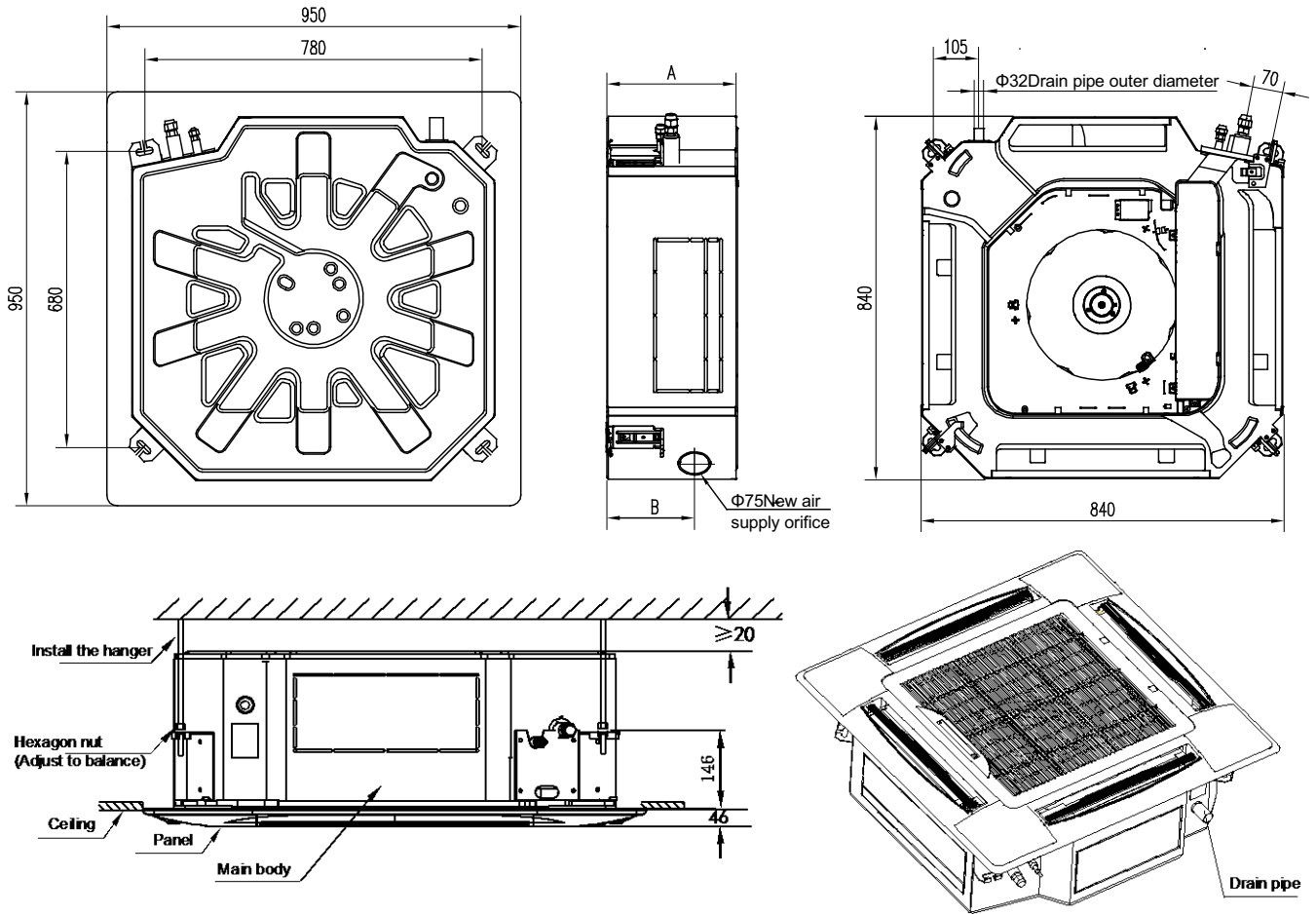

Table 2.1: Four-way Cassette dimensions

Model names	Dimensions (mm)	
	A	B
MVD-56Q4DN1 MVD-71Q4DN1 MVD-80Q4DN1	230	126
MVD-90Q4DN1 MVD-112Q4DN1 MVD-140Q4DN1	300	197

Table 2.2: Four-way Cassette piping connections

Model names	Gas pipe (mm)	Liquid pipe (mm)
MVD-56Q4DN1 MVD-71Q4DN1 MVD-90Q4DN1 MVD-112Q4DN1 MVD-140Q4DN1	$\Phi 15.9$	$\Phi 9.53$

# The 2<sup>nd</sup> Generation DC Series VRF Indoor Units

## 3 Unit Placement

### 3.1 Placement Considerations

Unit placement should take account of the following considerations:

- Units should not be installed in the following locations:
  - Where exposure to direct radiation from a high-temperature heat source or to interference from a source of electromagnetic radiation may occur.
  - Where dust or dirt may affect heat exchangers.
  - Where exposure to oil or to corrosive or harmful gases, such as acidic or alkaline gases, may occur.
  - Where exposure to salinity may occur, such as seaside locations.
  - Where highly flammable materials are present.
  - Where exposure to oily air may occur, such as a kitchen.
  - Where exposure to very high humidity may occur, such as a laundry.
- Units should be installed in positions where:
  - The ceiling is horizontal and is able to bear the unit's weight.
  - There are no obstructions that could impede the airflow into and out of the unit.
  - The airflow out of the unit can reach throughout the room.
  - There is sufficient space for access during installation, servicing and maintenance.
  - The refrigerant piping and drain piping can be easily connected to the refrigerant piping and drain piping systems.
  - Short-circuit ventilation (where outlet air returns quickly to a unit's air inlet) will not occur.

### 3.2 Space Requirements

Figure 3.1: Four-way Cassette space requirements (unit: mm)

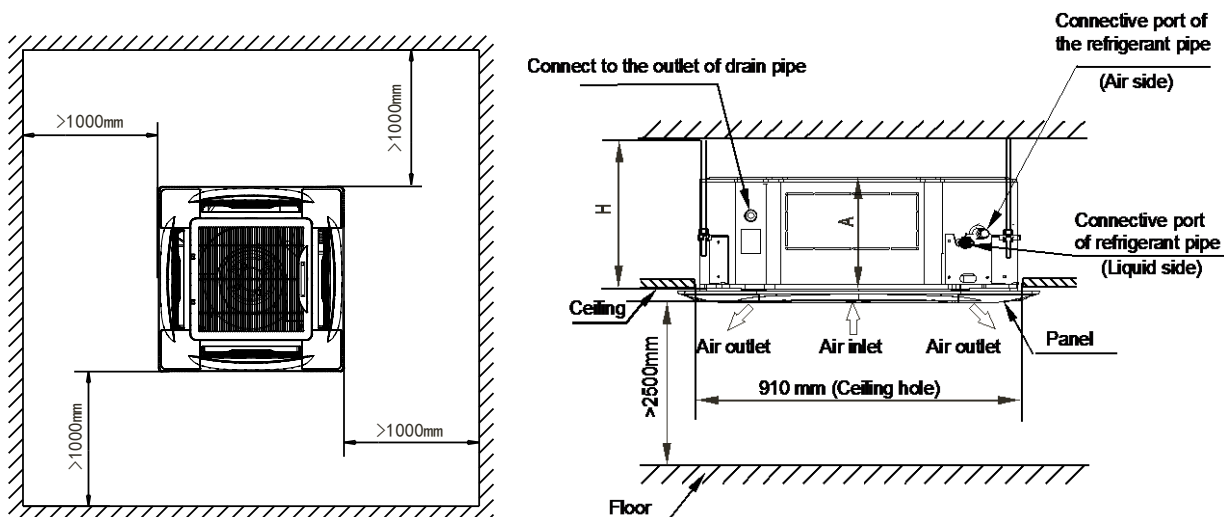

# The 2<sup>nd</sup> Generation DC Series VRF Indoor Units

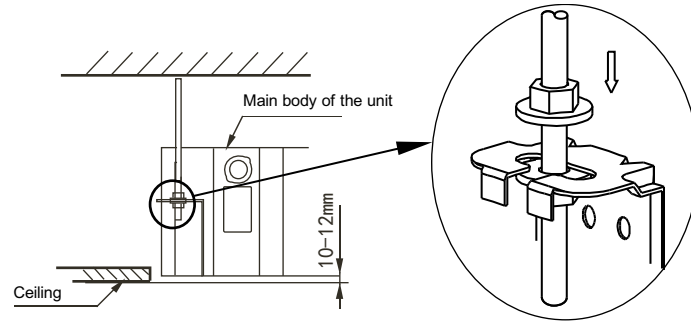

Table 3.1: Four-way Cassette dimensions and space requirements

Model name	Dimensions / Requirements (mm)	
	A	H
MVD-56Q4DN1 MVD-71Q4DN1 MVD-80Q4DN1	230	≥260
MVD-90Q4DN1 MVD-112Q4DN1 MVD-140Q4DN1	300	≥330



# The 2<sup>nd</sup> Generation DC Series VRF Indoor Units

## 4 Piping Diagram

Figure 4.1: Four-way Cassette piping diagram

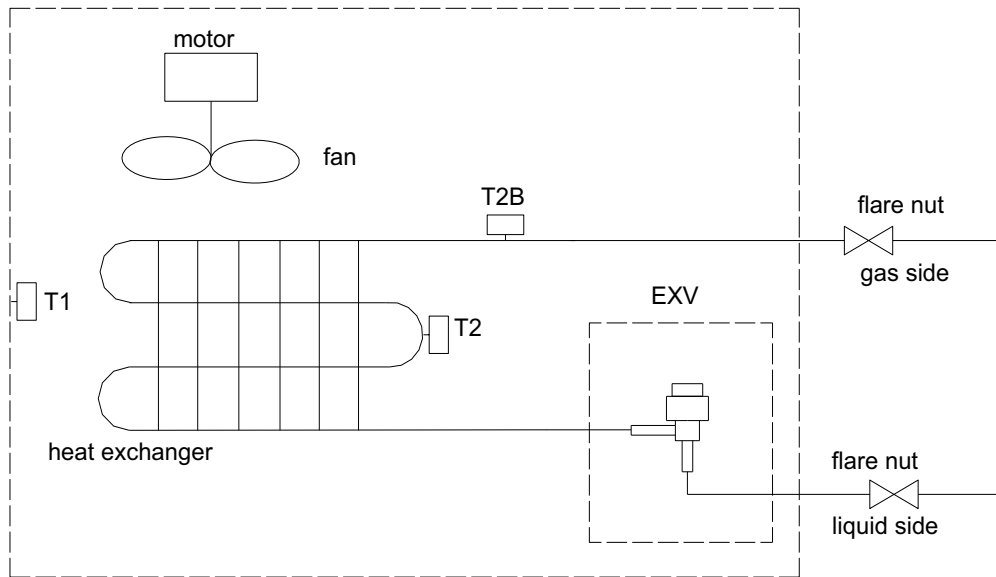

Legend	
T1	Indoor ambient temperature sensor
T2	Indoor heat exchanger mid-point temperature sensor
T2B	Indoor heat exchanger outlet temperature sensor

## 5 Wiring Diagram

Figure 5.1: MVD-56Q4DN1, MVD-71Q4DN1, MVD-80Q4DN1

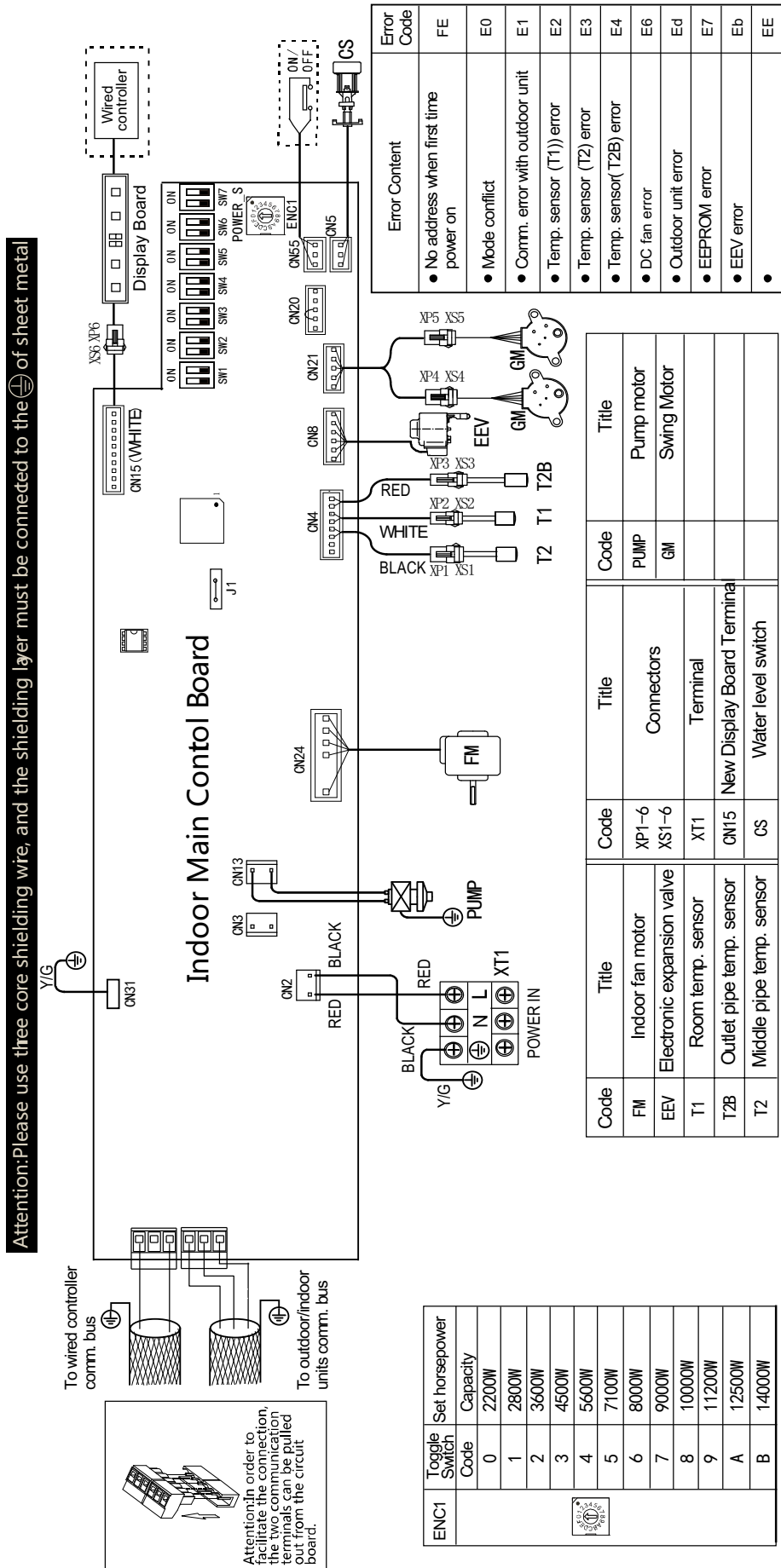

# The 2<sup>nd</sup> Generation DC Series VRF Indoor Units

Figure 5.2: MVD-90Q4DN1, MVD-112Q4DN1, MVD-140Q4DN1

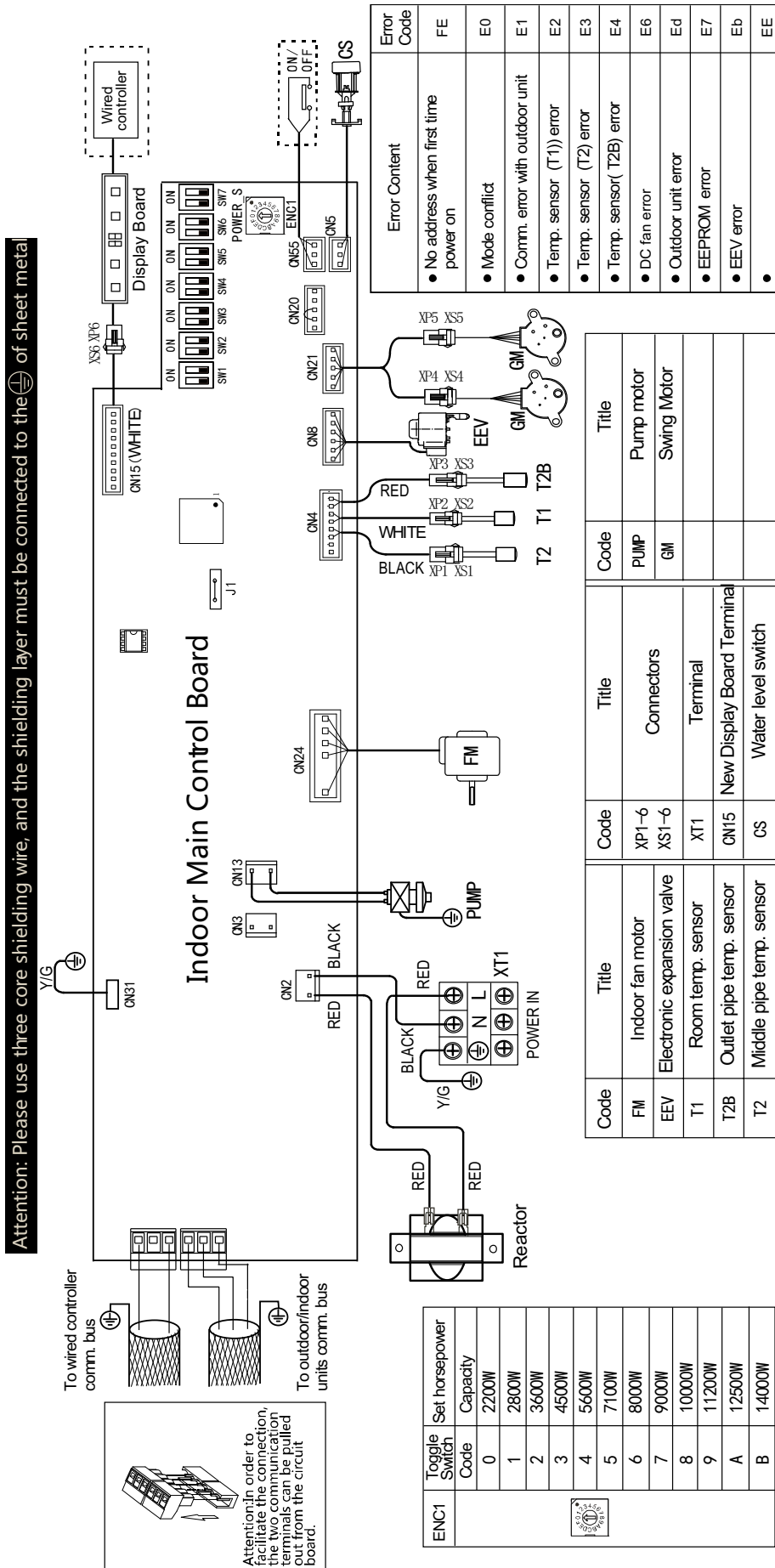

### Notes for installers and service engineers

#### Caution

- All installation, servicing and maintenance must be carried out by competent and suitably qualified, certified and accredited professionals and in accordance with all applicable legislation.
- Units should be grounded in accordance with all applicable legislation. Metal and other conductive components should be insulated in accordance with all applicable legislation.
- Power supply wiring should be securely fastened at the power supply terminals – loose power supply wiring would represent a fire risk.
- After installation, servicing or maintenance, the electric control box cover should be closed. Failing to close the electric control box cover risks fire or electric shock.
- Switch ENC1 (indoor unit capacity setting) is factory-set and its setting should normally not be changed. The only circumstances in which a switch ENC1 might need to be set in the field is when replacing a main PCB. When replacing a main PCB, ensure that the capacity setting on switch ENC1 on the new PCB is consistent with the unit capacity given on the unit's nameplate.

# The 2<sup>nd</sup> Generation DC Series VRF Indoor Units

## 6 Capacity Tables

### 6.1 Cooling Capacity Table

Table 6.1: Four-way Cassette cooling capacity

Capacity (kW)	Outdoor air temperature (°C DB)	Indoor air temperature (°C WB/DB)													
		14/20		16/23		18/26		19/27		20/28		22/30		24/32	
		TC	SC	TC	SC	TC	SC	TC	SC	TC	SC	TC	SC	TC	SC
		kW	kW	kW	kW	kW	kW	kW	kW	kW	kW	kW	kW	kW	kW
5.6	10.0	3.9	2.7	4.6	3.0	5.3	3.3	5.6	3.4	5.9	3.5	6.6	3.6	7.3	3.5
	12.0	3.9	2.7	4.6	3.0	5.3	3.3	5.6	3.4	5.9	3.5	6.6	3.6	7.2	3.5
	14.0	3.9	2.7	4.6	3.0	5.3	3.3	5.6	3.4	5.9	3.5	6.6	3.6	7.1	3.5
	16.0	3.9	2.7	4.6	3.0	5.3	3.3	5.6	3.4	5.9	3.5	6.6	3.6	7.0	3.4
	18.0	3.9	2.7	4.6	3.0	5.3	3.3	5.6	3.4	5.9	3.5	6.6	3.6	6.8	3.4
	20.0	3.9	2.7	4.6	3.0	5.3	3.3	5.6	3.4	5.9	3.5	6.6	3.6	6.7	3.3
	21.0	3.9	2.7	4.6	3.0	5.3	3.3	5.6	3.4	5.9	3.5	6.6	3.6	6.6	3.3
	23.0	3.9	2.7	4.6	3.0	5.3	3.3	5.6	3.4	5.9	3.5	6.6	3.6	6.6	3.3
	25.0	3.9	2.7	4.6	3.0	5.3	3.3	5.6	3.4	5.9	3.5	6.6	3.6	6.5	3.2
	27.0	3.9	2.7	4.6	3.0	5.3	3.3	5.6	3.4	5.9	3.5	6.4	3.5	6.4	3.2
	29.0	3.9	2.7	4.6	3.0	5.3	3.3	5.6	3.4	5.9	3.5	6.3	3.5	6.4	3.3
	31.0	3.9	2.7	4.6	3.0	5.3	3.3	5.6	3.4	5.9	3.5	6.2	3.4	6.2	3.2
	33.0	3.9	2.7	4.6	3.0	5.3	3.3	5.6	3.4	5.9	3.5	6.2	3.4	6.2	3.2
	35.0	3.9	2.7	4.6	3.0	5.3	3.3	5.6	3.4	5.9	3.5	6.0	3.3	6.0	3.1
	37.0	3.9	2.7	4.6	3.0	5.3	3.3	5.6	3.4	5.9	3.5	5.9	3.2	6.0	3.1
	39.0	3.9	2.7	4.6	3.0	5.3	3.3	5.6	3.4	5.7	3.4	5.8	3.2	6.0	3.1
42.0	3.9	2.7	4.6	3.0	5.3	3.3	5.6	3.4	5.7	3.4	5.8	3.2	6.0	3.1	
44.0	3.9	2.7	4.6	3.0	5.3	3.3	5.6	3.4	5.7	3.4	5.8	3.2	6.0	3.1	
46.0	3.9	2.7	4.6	3.0	5.3	3.3	5.6	3.4	5.7	3.7	5.8	3.2	6.0	3.1	
7.1	10.0	4.9	3.6	5.8	4.0	6.7	4.3	7.1	4.5	7.5	4.4	8.4	4.5	9.2	4.6
	12.0	4.9	3.6	5.8	4.0	6.7	4.3	7.1	4.5	7.5	4.4	8.4	4.5	9.1	4.5
	14.0	4.9	3.6	5.8	4.0	6.7	4.3	7.1	4.5	7.5	4.4	8.4	4.5	9.0	4.5
	16.0	4.9	3.6	5.8	4.0	6.7	4.3	7.1	4.5	7.5	4.4	8.4	4.5	8.9	4.4
	18.0	4.9	3.6	5.8	4.0	6.7	4.3	7.1	4.5	7.5	4.4	8.4	4.5	8.7	4.3
	20.0	4.9	3.6	5.8	4.0	6.7	4.3	7.1	4.5	7.5	4.4	8.4	4.5	8.5	4.2
	21.0	4.9	3.6	5.8	4.0	6.7	4.3	7.1	4.5	7.5	4.4	8.4	4.5	8.4	4.2
	23.0	4.9	3.6	5.8	4.0	6.7	4.3	7.1	4.5	7.5	4.4	8.4	4.5	8.3	4.1
	25.0	4.9	3.6	5.8	4.0	6.7	4.3	7.1	4.5	7.5	4.4	8.4	4.5	8.2	4.1
	27.0	4.9	3.6	5.8	4.0	6.7	4.3	7.1	4.5	7.5	4.4	8.1	4.3	8.2	4.1
	29.0	4.9	3.6	5.8	4.0	6.7	4.3	7.1	4.5	7.5	4.5	8.0	4.3	8.1	4.1
	31.0	4.9	3.6	5.8	4.0	6.7	4.3	7.1	4.5	7.5	4.5	7.9	4.3	7.8	4.0
	33.0	4.9	3.6	5.8	4.0	6.7	4.3	7.1	4.5	7.5	4.5	7.8	4.2	7.8	4.0
	35.0	4.9	3.6	5.8	4.0	6.7	4.3	7.1	4.5	7.5	4.5	7.6	4.1	7.7	3.9
	37.0	4.9	3.6	5.8	4.0	6.7	4.3	7.1	4.5	7.4	4.4	7.5	4.1	7.6	4.0
	39.0	4.9	3.6	5.8	4.0	6.7	4.3	7.1	4.5	7.2	4.3	7.4	4.1	7.6	4.0
42.0	4.9	3.6	5.8	4.0	6.7	4.3	7.1	4.5	7.2	4.3	7.4	4.1	7.6	4.0	
44.0	4.9	3.6	5.8	4.0	6.7	4.3	7.1	4.5	7.2	4.3	7.4	4.1	7.6	4.0	
46.0	4.9	3.6	5.8	4.0	6.7	4.3	7.1	4.5	7.2	4.3	7.4	4.1	7.6	4.0	

Abbreviations:  
 TC: Total capacity  
 SC: Sensible capacity

Notes:  
 1. Shaded cells indicate rating condition.

Table continued on next page ...

# The 2<sup>nd</sup> Generation DC Series VRF Indoor Units

Table 6.1: Four-way Cassette cooling capacity (continued)

Capacity (kW)	Outdoor air temperature (°C DB)	Indoor air temperature (°C WB/DB)													
		14/20		16/23		18/26		19/27		20/28		22/30		24/32	
		TC	SC	TC	SC	TC	SC	TC	SC	TC	SC	TC	SC	TC	SC
		kW	kW	kW	kW	kW	kW	kW	kW	kW	kW	kW	kW	kW	kW
8.0	10.0	5.5	4.4	6.6	4.9	7.5	5.3	8.0	5.5	8.4	5.4	9.4	5.5	10.4	5.6
	12.0	5.5	4.4	6.6	4.9	7.5	5.3	8.0	5.5	8.4	5.4	9.4	5.5	10.2	5.5
	14.0	5.5	4.4	6.6	4.9	7.5	5.3	8.0	5.5	8.4	5.4	9.4	5.5	10.2	5.5
	16.0	5.5	4.4	6.6	4.9	7.5	5.3	8.0	5.5	8.4	5.4	9.4	5.5	10.0	5.4
	18.0	5.5	4.4	6.6	4.9	7.5	5.3	8.0	5.5	8.4	5.4	9.4	5.5	9.8	5.3
	20.0	5.5	4.4	6.6	4.9	7.5	5.3	8.0	5.5	8.4	5.4	9.4	5.5	9.6	5.2
	21.0	5.5	4.4	6.6	4.9	7.5	5.3	8.0	5.5	8.4	5.4	9.4	5.5	9.4	5.1
	23.0	5.5	4.4	6.6	4.9	7.5	5.3	8.0	5.5	8.4	5.4	9.4	5.5	9.4	5.1
	25.0	5.5	4.4	6.6	4.9	7.5	5.3	8.0	5.5	8.4	5.4	9.4	5.5	9.3	5.0
	27.0	5.5	4.4	6.6	4.9	7.5	5.3	8.0	5.5	8.4	5.4	9.1	5.3	9.2	5.1
	29.0	5.5	4.4	6.6	4.9	7.5	5.3	8.0	5.5	8.4	5.5	9.0	5.3	9.1	5.0
	31.0	5.5	4.4	6.6	4.9	7.5	5.3	8.0	5.5	8.4	5.5	8.9	5.2	8.8	4.8
	33.0	5.5	4.4	6.6	4.9	7.5	5.3	8.0	5.5	8.4	5.5	8.8	5.2	8.8	4.8
	35.0	5.5	4.4	6.6	4.9	7.5	5.3	8.0	5.5	8.4	5.5	8.6	5.1	8.6	4.8
	37.0	5.5	4.4	6.6	4.9	7.5	5.3	8.0	5.5	8.3	5.4	8.4	5.0	8.6	4.9
	39.0	5.5	4.4	6.6	4.9	7.5	5.3	8.0	5.5	8.1	5.3	8.3	5.0	8.6	4.9
	42.0	5.5	4.4	6.6	4.9	7.5	5.3	8.0	5.5	8.1	5.3	8.3	5.0	8.6	4.9
44.0	5.5	4.4	6.6	4.9	7.5	5.3	8.0	5.5	8.1	5.3	8.3	5.0	8.6	4.9	
46.0	5.5	4.4	6.6	4.9	7.5	5.3	8.0	5.5	8.1	5.3	8.3	5.0	8.6	4.9	
9.0	10.0	6.2	4.9	7.3	5.3	8.4	5.8	9.0	5.9	9.6	6.0	10.6	6.1	11.7	6.0
	12.0	6.2	4.9	7.3	5.3	8.4	5.8	9.0	5.9	9.6	6.0	10.6	6.1	11.5	5.9
	14.0	6.2	4.9	7.3	5.3	8.4	5.8	9.0	5.9	9.6	6.0	10.6	6.1	11.4	5.9
	16.0	6.2	4.9	7.3	5.3	8.4	5.8	9.0	5.9	9.6	6.0	10.6	6.1	11.3	5.8
	18.0	6.2	4.9	7.3	5.3	8.4	5.8	9.0	5.9	9.6	6.0	10.6	6.1	11.0	5.8
	20.0	6.2	4.9	7.3	5.3	8.4	5.8	9.0	5.9	9.6	6.0	10.6	6.1	10.8	5.7
	21.0	6.2	4.9	7.3	5.3	8.4	5.8	9.0	5.9	9.6	6.0	10.6	6.1	10.6	5.6
	23.0	6.2	4.9	7.3	5.3	8.4	5.8	9.0	5.9	9.6	6.0	10.6	6.1	10.5	5.5
	25.0	6.2	4.9	7.3	5.3	8.4	5.8	9.0	5.9	9.6	6.0	10.6	6.1	10.4	5.5
	27.0	6.2	4.9	7.3	5.3	8.4	5.8	9.0	5.9	9.6	6.0	10.3	5.9	10.4	5.4
	29.0	6.2	4.9	7.3	5.3	8.4	5.8	9.0	5.9	9.6	6.0	10.1	5.7	10.3	5.4
	31.0	6.2	4.9	7.3	5.3	8.4	5.8	9.0	5.9	9.6	6.0	10.0	5.7	9.9	5.3
	33.0	6.2	4.9	7.3	5.3	8.4	5.8	9.0	5.9	9.6	6.0	9.9	5.6	9.9	5.3
	35.0	6.2	4.9	7.3	5.3	8.4	5.8	9.0	5.9	9.5	6.0	9.6	5.5	9.7	5.3
	37.0	6.2	4.9	7.3	5.3	8.4	5.8	9.0	5.9	9.3	5.8	9.5	5.4	9.6	5.3
	39.0	6.2	4.9	7.3	5.3	8.4	5.8	9.0	5.9	9.2	5.7	9.4	5.3	9.6	5.3
	42.0	6.2	4.9	7.3	5.3	8.4	5.8	9.0	5.9	9.2	5.7	9.4	5.3	9.6	5.3
44.0	6.2	4.9	7.3	5.3	8.4	5.8	9.0	5.9	9.2	5.7	9.4	5.3	9.6	5.3	
46.0	6.2	4.9	7.3	5.3	8.4	5.8	9.0	5.9	9.2	5.7	9.4	5.3	9.6	5.3	

Abbreviations:  
 TC: Total capacity  
 SC: Sensible capacity

Notes:  
 1. Shaded cells indicate rating condition.

Table continued on next page ...

# The 2<sup>nd</sup> Generation DC Series VRF Indoor Units

Table 6.1: Four-way Cassette cooling capacity (continued)

Capacity (kW)	Outdoor air temperature (°C DB)	Indoor air temperature (°C WB/DB)													
		14/20		16/23		18/26		19/27		20/28		22/30		24/32	
		TC	SC	TC	SC	TC	SC	TC	SC	TC	SC	TC	SC	TC	SC
		kW	kW	kW	kW	kW	kW	kW	kW	kW	kW	kW	kW	kW	kW
11.2	10.0	7.7	5.9	9.1	6.5	10.5	7.1	11.2	7.2	11.9	7.4	13.3	7.6	15.5	8.2
	12.0	7.7	5.9	9.1	6.5	10.5	7.1	11.2	7.2	11.9	7.4	13.3	7.6	14.4	7.7
	14.0	7.7	5.9	9.1	6.5	10.5	7.1	11.2	7.2	11.9	7.4	13.3	7.6	14.2	7.6
	16.0	7.7	5.9	9.1	6.5	10.5	7.1	11.2	7.2	11.9	7.4	13.3	7.6	14.1	7.5
	18.0	7.7	5.9	9.1	6.5	10.5	7.1	11.2	7.2	11.9	7.4	13.3	7.6	14.0	7.5
	20.0	7.7	5.9	9.1	6.5	10.5	7.1	11.2	7.2	11.9	7.4	13.3	7.6	13.9	7.4
	21.0	7.7	5.9	9.1	6.5	10.5	7.1	11.2	7.2	11.9	7.4	13.3	7.6	13.8	7.4
	23.0	7.7	5.9	9.1	6.5	10.5	7.1	11.2	7.2	11.9	7.4	13.1	7.5	13.7	7.3
	25.0	7.7	5.9	9.1	6.5	10.5	7.1	11.2	7.2	11.9	7.4	13.0	7.4	13.6	7.2
	27.0	7.7	5.9	9.1	6.5	10.5	7.1	11.2	7.2	11.9	7.4	12.9	7.3	13.4	7.2
	29.0	7.7	5.9	9.1	6.5	10.5	7.1	11.2	7.2	11.9	7.4	12.8	7.3	13.3	7.2
	31.0	7.7	5.9	9.1	6.5	10.5	7.1	11.2	7.2	11.9	7.4	12.7	7.2	12.8	6.9
	33.0	7.7	5.9	9.1	6.5	10.5	7.1	11.2	7.2	11.9	7.4	12.5	7.2	12.5	6.8
	35.0	7.7	5.9	9.1	6.5	10.5	7.1	11.2	7.2	11.8	7.4	12.4	7.1	12.3	6.7
	37.0	7.7	5.9	9.1	6.5	10.5	7.1	11.2	7.2	11.6	7.3	12.3	7.0	12.1	6.6
	39.0	7.7	5.9	9.1	6.5	10.5	7.1	11.2	7.2	11.4	7.1	12.2	7.0	11.9	6.6
42.0	7.7	6.0	9.1	6.6	10.4	7.2	11.2	7.3	11.4	7.1	11.6	6.6	12.0	6.6	
44.0	7.7	6.0	9.1	6.6	10.4	7.2	11.2	7.3	11.4	7.1	11.6	6.6	12.0	6.6	
46.0	7.7	6.0	9.1	6.6	10.4	7.2	11.2	7.3	11.4	7.1	11.6	6.6	12.0	6.6	
14.0	10.0	9.7	7.2	11.3	7.9	13.2	8.8	14.0	9.0	14.8	9.0	16.7	9.3	18.2	9.4
	12.0	9.7	7.2	11.3	7.9	13.2	8.8	14.0	9.0	14.8	9.0	16.7	9.3	17.9	9.2
	14.0	9.7	7.2	11.3	7.9	13.2	8.8	14.0	9.0	14.8	9.0	16.7	9.3	17.8	9.2
	16.0	9.7	7.2	11.3	7.9	13.2	8.8	14.0	9.0	14.8	9.0	16.7	9.3	17.5	9.0
	18.0	9.7	7.2	11.3	7.9	13.2	8.8	14.0	9.0	14.8	9.0	16.7	9.3	17.1	8.8
	20.0	9.7	7.2	11.3	7.9	13.2	8.8	14.0	9.0	14.8	9.0	16.7	9.3	16.8	8.7
	21.0	9.7	7.2	11.3	7.9	13.2	8.8	14.0	9.0	14.8	9.0	16.7	9.3	16.5	8.5
	23.0	9.7	7.2	11.3	7.9	13.2	8.8	14.0	9.0	14.8	9.0	16.4	9.3	16.4	8.4
	25.0	9.7	7.2	11.3	7.9	13.2	8.8	14.0	9.0	14.8	9.0	16.2	9.3	16.2	8.4
	27.0	9.7	7.2	11.3	7.9	13.2	8.8	14.0	9.0	14.8	9.0	16.1	9.2	16.1	8.4
	29.0	9.7	7.2	11.3	7.9	13.2	8.8	14.0	9.0	14.8	9.0	16.0	9.1	16.0	8.4
	31.0	9.7	7.2	11.3	7.9	13.2	8.8	14.0	9.0	14.8	9.0	15.8	9.0	15.4	8.1
	33.0	9.7	7.2	11.3	7.9	13.2	8.8	14.0	9.0	14.8	9.0	15.7	8.9	15.4	8.1
	35.0	9.7	7.2	11.3	7.9	13.2	8.8	14.0	9.0	14.7	8.9	15.1	8.6	15.1	8.1
	37.0	9.7	7.2	11.3	7.9	13.2	8.8	14.0	9.0	14.6	8.8	15.1	8.6	15.0	8.0
	39.0	9.7	7.2	11.3	7.9	13.2	8.8	14.0	9.0	14.3	8.7	14.6	8.4	15.0	8.1
42.0	9.7	7.2	11.3	7.9	13.2	8.8	14.0	9.0	14.3	8.7	14.6	8.4	15.0	8.1	
44.0	9.7	7.2	11.3	7.9	13.2	8.8	14.0	9.0	14.3	8.7	14.6	8.4	15.0	8.1	
46.0	9.7	7.2	11.3	7.9	13.2	8.8	14.0	9.0	14.3	8.7	14.6	8.4	15.0	8.1	

Abbreviations:

TC: Total capacity

SC: Sensible capacity

Notes:

1. Shaded cells indicate rating condition.

# The 2<sup>nd</sup> Generation DC Series VRF Indoor Units

## 6.2 Heating Capacity Table

Table 6.2: Four-way Cassette heating capacity (continued)

Capacity (kW)	Outdoor air temperature (°C)		Indoor air temperature (°C DB)					
			16	18	20	21	22	24
	WB	DB	TC kW	TC kW	TC kW	TC kW	TC kW	TC kW
5.6	-20	-19.8	3.53	3.53	3.53	3.53	3.53	3.53
	-19	-18.8	3.78	3.78	3.78	3.78	3.78	3.78
	-17	-16.7	3.97	3.97	3.97	3.97	3.97	3.97
	-15	-14.7	4.10	4.10	4.10	4.10	4.10	4.10
	-13.00	-12.60	4.22	4.22	4.22	4.22	4.22	4.22
	-11.00	-10.50	4.41	4.41	4.41	4.41	4.41	4.41
	-10.00	-9.50	4.60	4.60	4.60	4.60	4.60	4.60
	-9.10	-8.50	4.73	4.73	4.73	4.73	4.73	4.73
	-7.60	-7.00	4.79	4.79	4.79	4.79	4.79	4.79
	-5.60	-5.00	4.98	4.98	4.98	4.98	4.98	4.98
	-3.70	-3.00	5.23	5.23	5.23	5.23	5.23	5.23
	-0.70	0.00	5.61	5.61	5.61	5.61	5.61	5.29
	2.20	3.00	5.92	5.92	5.92	5.92	5.80	5.29
	4.10	5.00	6.11	6.11	6.11	6.11	5.80	5.29
	6.00	7.00	6.30	6.30	<b>6.30</b>	6.11	5.80	5.29
	7.90	9.00	6.49	6.49	6.30	6.11	5.80	5.29
9.80	11.00	6.68	6.68	6.30	6.11	5.80	5.29	
11.80	13.00	6.93	6.80	6.30	6.11	5.80	5.29	
13.70	15.00	7.12	6.80	6.30	6.11	5.80	5.29	
7.1	-20	-19.8	4.48	4.48	4.48	4.48	4.48	4.48
	-19	-18.8	4.80	4.80	4.80	4.80	4.80	4.80
	-17	-16.7	5.04	5.04	5.04	5.04	5.04	5.04
	-15	-14.7	5.20	5.20	5.20	5.20	5.20	5.20
	-13.00	-12.60	5.36	5.36	5.36	5.36	5.36	5.36
	-11.00	-10.50	5.60	5.60	5.60	5.60	5.60	5.60
	-10.00	-9.50	5.84	5.84	5.84	5.84	5.84	5.84
	-9.10	-8.50	6.00	6.00	6.00	6.00	6.00	6.00
	-7.60	-7.00	6.08	6.08	6.08	6.08	6.08	6.08
	-5.60	-5.00	6.32	6.32	6.32	6.32	6.32	6.32
	-3.70	-3.00	6.64	6.64	6.64	6.64	6.64	6.64
	-0.70	0.00	7.12	7.12	7.12	7.12	7.12	6.72
	2.20	3.00	7.52	7.52	7.52	7.52	7.36	6.72
	4.10	5.00	7.76	7.76	7.76	7.76	7.36	6.72
	6.00	7.00	8.00	8.00	<b>8.00</b>	7.76	7.36	6.72
	7.90	9.00	8.24	8.24	8.00	7.76	7.36	6.72
9.80	11.00	8.48	8.48	8.00	7.76	7.36	6.72	
11.80	13.00	8.80	8.64	8.00	7.76	7.36	6.72	
13.70	15.00	9.04	8.64	8.00	7.76	7.36	6.72	

Abbreviations:  
TC: Total capacity

Notes:

1. Shaded cells indicate rating condition.

Table continued on next page ...



# The 2<sup>nd</sup> Generation DC Series VRF Indoor Units

Table 6.2: Four-way Cassette heating capacity (continued)

Capacity (kW)	Outdoor air temperature (°C)		Indoor air temperature (°C DB)					
			16	18	20	21	22	24
	WB	DB	TC	TC	TC	TC	TC	TC
8.0	-20	-19.8	5.04	5.04	5.04	5.04	5.04	5.04
	-19	-18.8	5.40	5.40	5.40	5.40	5.40	5.40
	-17	-16.7	5.67	5.67	5.67	5.67	5.67	5.67
	-15	-14.7	5.85	5.85	5.85	5.85	5.85	5.85
	-13.00	-12.60	6.03	6.03	6.03	6.03	6.03	6.03
	-11.00	-10.50	6.30	6.30	6.30	6.30	6.30	6.30
	-10.00	-9.50	6.57	6.57	6.57	6.57	6.57	6.57
	-9.10	-8.50	6.75	6.75	6.75	6.75	6.75	6.75
	-7.60	-7.00	6.84	6.84	6.84	6.84	6.84	6.84
	-5.60	-5.00	7.11	7.11	7.11	7.11	7.11	7.11
	-3.70	-3.00	7.47	7.47	7.47	7.47	7.47	7.47
	-0.70	0.00	8.01	8.01	8.01	8.01	8.01	7.56
	2.20	3.00	8.46	8.46	8.46	8.46	8.28	7.56
	4.10	5.00	8.73	8.73	8.73	8.73	8.28	7.56
	6.00	7.00	9.00	9.00	9.00	8.73	8.28	7.56
	7.90	9.00	9.27	9.27	9.00	8.73	8.28	7.56
9.80	11.00	9.54	9.54	9.00	8.73	8.28	7.56	
11.80	13.00	9.90	9.72	9.00	8.73	8.28	7.56	
13.70	15.00	10.17	9.72	9.00	8.73	8.28	7.56	
9.0	-20	-19.8	5.60	5.04	5.60	5.60	5.60	5.60
	-19	-18.8	6.00	5.40	6.00	6.00	6.00	6.00
	-17	-16.7	6.30	6.30	6.30	6.30	6.30	6.30
	-15	-14.7	6.50	6.50	6.50	6.50	6.50	6.50
	-13.00	-12.60	6.70	6.70	6.70	6.70	6.70	6.70
	-11.00	-10.50	7.00	7.00	7.00	7.00	7.00	7.00
	-10.00	-9.50	7.30	7.30	7.30	7.30	7.30	7.30
	-9.10	-8.50	7.50	7.50	7.50	7.50	7.50	7.50
	-7.60	-7.00	7.60	7.60	7.60	7.60	7.60	7.60
	-5.60	-5.00	7.90	7.90	7.90	7.90	7.90	7.90
	-3.70	-3.00	8.30	8.30	8.30	8.30	8.30	8.30
	-0.70	0.00	8.90	8.90	8.90	8.90	8.90	8.40
	2.20	3.00	9.40	9.40	9.40	9.40	9.20	8.40
	4.10	5.00	9.70	9.70	9.70	9.70	9.20	8.40
	6.00	7.00	10.00	10.00	10.00	9.70	9.20	8.40
	7.90	9.00	10.30	10.30	10.00	9.70	9.20	8.40
9.80	11.00	10.60	10.60	10.00	9.70	9.20	8.40	
11.80	13.00	11.00	10.80	10.00	9.70	9.20	8.40	
13.70	15.00	11.30	10.80	10.00	9.70	9.20	8.40	

Abbreviations:  
TC: Total capacity

Notes:  
1. Shaded cells indicate rating condition.

Table continued on next page ...

# The 2<sup>nd</sup> Generation DC Series VRF Indoor Units

Table 6.2: Four-way Cassette heating capacity (continued)

Capacity (kW)	Outdoor air temperature (°C)		Indoor air temperature (°C DB)					
			16	18	20	21	22	24
	WB	DB	TC	TC	TC	TC	TC	TC
11.2	-20	-19.8	7.00	7.00	7.00	7.00	7.00	7.00
	-19	-18.8	7.50	7.50	7.50	7.50	7.50	7.50
	-17	-16.7	7.88	7.88	7.88	7.88	7.88	7.88
	-15	-14.7	8.13	8.13	8.13	8.13	8.13	8.13
	-13.00	-12.60	8.38	8.38	8.38	8.38	8.38	8.38
	-11.00	-10.50	8.75	8.75	8.75	8.75	8.75	8.75
	-10.00	-9.50	9.13	9.13	9.13	9.13	9.13	9.13
	-9.10	-8.50	9.38	9.38	9.38	9.38	9.38	9.38
	-7.60	-7.00	9.50	9.50	9.50	9.50	9.50	9.50
	-5.60	-5.00	9.88	9.88	9.88	9.88	9.88	9.88
	-3.70	-3.00	10.38	10.38	10.38	10.38	10.38	10.38
	-0.70	0.00	11.13	11.13	11.13	11.13	11.13	10.50
	2.20	3.00	11.75	11.75	11.75	11.75	11.50	10.50
	4.10	5.00	12.13	12.13	12.13	12.13	11.50	10.50
	6.00	7.00	12.50	12.50	12.50	12.13	11.50	10.50
	7.90	9.00	12.88	12.88	12.50	12.13	11.50	10.50
	9.80	11.00	13.25	13.25	12.50	12.13	11.50	10.50
11.80	13.00	13.75	13.50	12.50	12.13	11.50	10.50	
13.70	15.00	14.13	13.50	12.50	12.13	11.50	10.50	
14.0	-20	-19.8	8.96	8.96	8.96	8.96	8.96	8.96
	-19	-18.8	9.60	9.60	9.60	9.60	9.60	9.60
	-17	-16.7	10.08	10.08	10.08	10.08	10.08	10.08
	-15	-14.7	10.40	10.40	10.40	10.40	10.40	10.40
	-13.00	-12.60	11.04	11.04	11.04	11.04	11.04	11.04
	-11.00	-10.50	11.20	11.36	11.36	11.36	11.36	11.36
	-10.00	-9.50	11.68	11.68	11.68	11.68	11.68	11.68
	-9.10	-8.50	12.00	12.00	12.00	12.00	12.00	12.00
	-7.60	-7.00	12.16	12.16	12.16	12.16	12.16	12.16
	-5.60	-5.00	12.64	12.64	12.64	12.64	12.64	12.64
	-3.70	-3.00	13.28	13.28	13.28	13.28	13.28	13.28
	-0.70	0.00	14.24	14.24	14.24	14.24	14.24	13.44
	2.20	3.00	15.04	15.04	15.04	15.04	14.72	13.44
	4.10	5.00	15.52	15.52	15.52	15.52	14.72	13.44
	6.00	7.00	16.00	16.00	16.00	15.52	14.72	13.44
	7.90	9.00	16.48	16.48	16.00	15.52	14.72	13.44
	9.80	11.00	16.96	16.96	16.00	15.52	14.72	13.44
11.80	13.00	17.60	17.28	16.00	15.52	14.72	13.44	
13.70	15.00	18.08	17.28	16.00	15.52	14.72	13.44	

Abbreviations:

TC: Total capacity

Notes:

1. Shaded cells indicate rating condition.

# The 2<sup>nd</sup> Generation DC Series VRF Indoor Units

## 7 Electrical Characteristics

Table 7.1: Four-way Cassette electrical characteristics

Model name	Power supply						Indoor fan motors	
	Hz	Volts	Min. volts	Max. volts	MCA	MFA	Rated motor output (kW)	FLA
MVD-56Q4DN1	50	220-240	198	264	0.56	15	0.08	0.45
MVD-71Q4DN1	50	220-240	198	264	0.56	15	0.08	0.45
MVD-80Q4DN1	50	220-240	198	264	0.76	15	0.08	0.61
MVD-90Q4DN1	50	220-240	198	264	0.88	15	0.17	0.70
MVD-112Q4DN1	50	220-240	198	264	1.00	15	0.17	0.80
MVD-140Q4DN1	50	220-240	198	264	1.20	15	0.17	0.96

Abbreviations:

MCA: Minimum Circuit Amps

MFA: Maximum Fuse Amps

FLA: Full Load Amps

## 8 Sound Levels

### 8.1 Overall

Table 8.1: Four-way Cassette sound pressure levels<sup>1</sup>

Model name	Sound pressure levels dB(A)						
	SSH	SH	H	M	L	SL	SSL
MVD-56Q4DN1	35	34	31	31	30	28	26
MVD-71Q4DN1	35	35	34	31	30	28	27
MVD-80Q4DN1	36	35	34	31	31	29	28
MVD-90Q4DN1	37	35	34	31	31	30	28
MVD-112Q4DN1	38	36	35	34	31	31	30
MVD-140Q4DN1	39	37	36	35	34	31	31

Notes:

1. Sound pressure levels are measured 1.4m below the unit in a semi-anechoic chamber. During in-situ operation, sound pressure levels may be higher as a result of ambient noise.

Figure 8.1: Four-way Cassette sound pressure level measurement

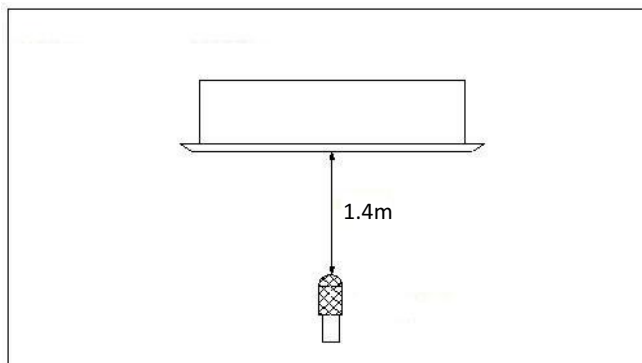

### 8.2 Octave Band Levels

Figure 8.1: MVD-56Q4DN1 octave band levels

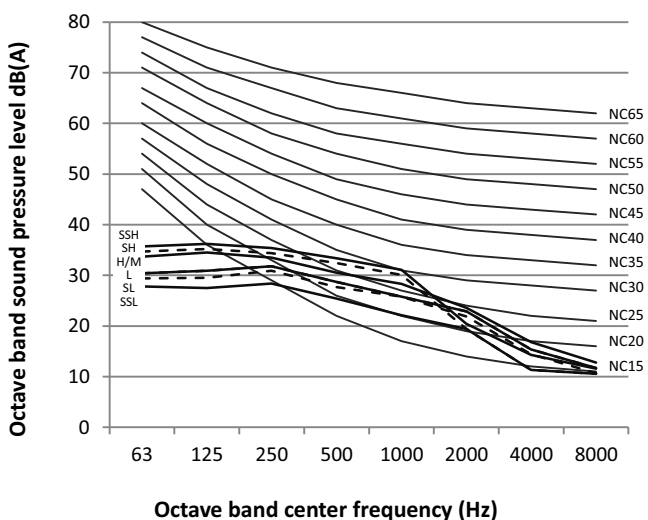

Figure 8.2: MVD-71Q4DN1 octave band levels

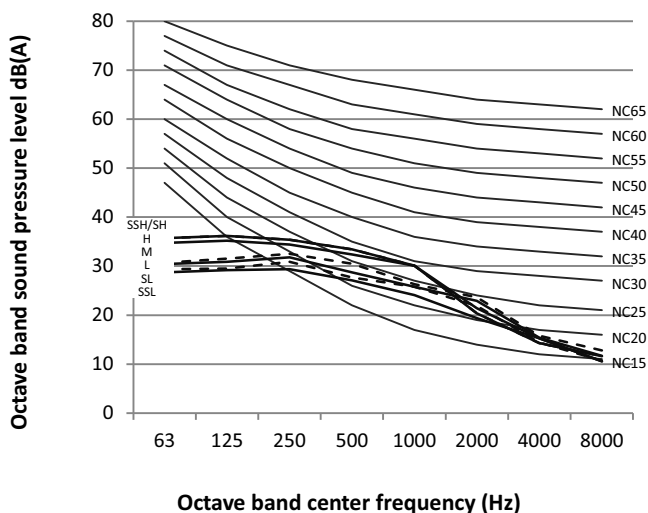

Figure 8.3: MVD-80Q4DN1 octave band levels

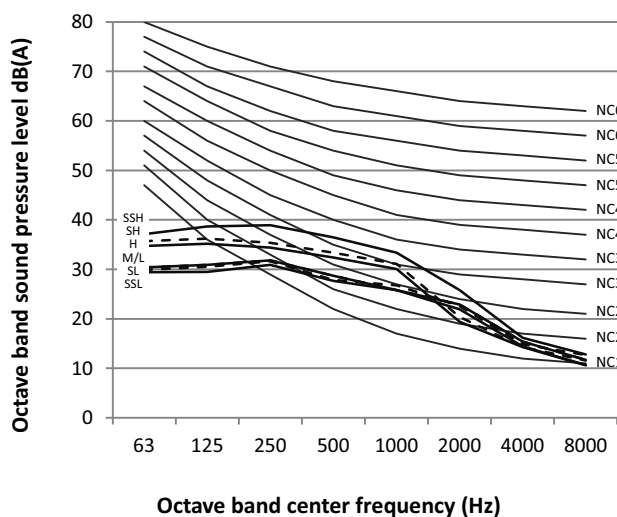
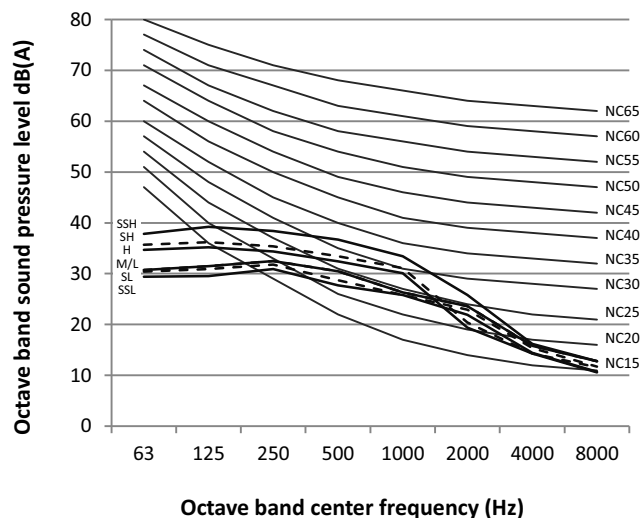

Figure 8.4: MVD-90Q4DN1 octave band levels



# The 2<sup>nd</sup> Generation DC Series VRF Indoor Units

Figure 8.5: MVD-112Q4DN1 octave band levels

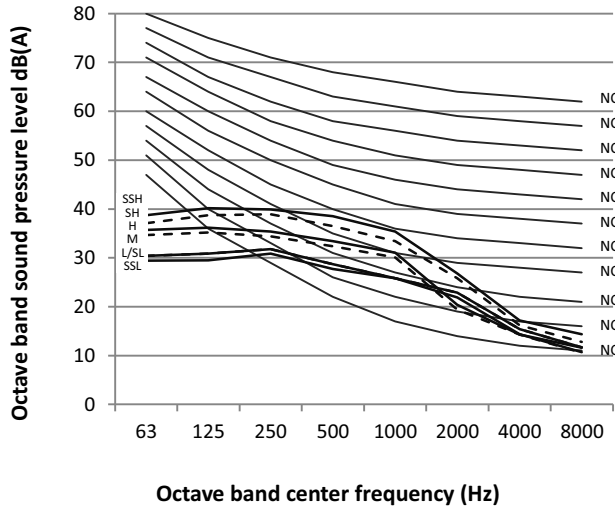
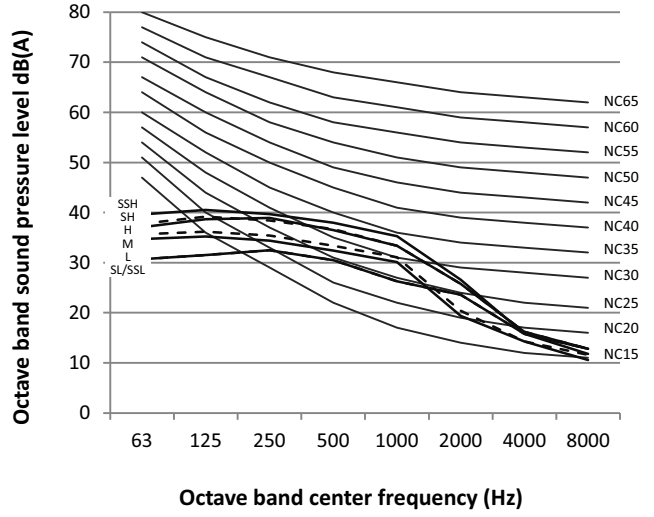

Figure 8.6: MVD-140Q4DN1 octave band levels



## 9 Error codes

With the exception of a mode conflict error, contact your supplier or service engineer if any of the error codes listed in the following table are displayed on the unit's display panel. If the mode conflict error is displayed and persists, contact your supplier or service engineer. These errors should only be investigated by a professional technician. The descriptions are provided in this manual for reference only.

Content	Digital display output	Possible causes
Mode conflict	E0	<ul style="list-style-type: none"> <li>♦ The indoor unit's operating mode conflicts with that of the outdoor units.</li> </ul>
Communication error between indoor and outdoor units	E1	<ul style="list-style-type: none"> <li>♦ Communication wires between indoor and outdoor units not connected properly.</li> <li>♦ Interference from high voltage wires or other sources of electromagnetic radiation.</li> <li>♦ Communication wire too long.</li> <li>♦ Damaged main PCB.</li> </ul>
Indoor ambient temperature sensor (T1) error	E2	<ul style="list-style-type: none"> <li>♦ Temperature sensor not connected properly or has malfunctioned.</li> <li>♦ Damaged main PCB.</li> </ul>
Indoor heat exchanger mid-point temperature sensor (T2) error	E3	
Indoor heat exchanger outlet temperature sensor (T2B) error	E4	
Fan error	E6	<ul style="list-style-type: none"> <li>♦ Fan stuck or blocked.</li> <li>♦ Fan motor not connected properly or has malfunctioned.</li> <li>♦ Power supply abnormal.</li> <li>♦ Damaged main PCB.</li> </ul>
EEPROM mismatch	E7	<ul style="list-style-type: none"> <li>♦ Damaged main PCB.</li> </ul>
EEV error	Eb	<ul style="list-style-type: none"> <li>♦ Line loosened or broken.</li> <li>♦ The electronic expansion valve is stuck.</li> <li>♦ Damaged main PCB.</li> </ul>
Outdoor unit error	Ed	<ul style="list-style-type: none"> <li>♦ Outdoor unit error.</li> </ul>
Water level error	EE	<ul style="list-style-type: none"> <li>♦ Water level float stuck.</li> <li>♦ Water level switch not connected properly.</li> <li>♦ Damaged main PCB.</li> <li>♦ Drain pump has malfunctioned.</li> </ul>
The indoor unit has not been assigned an address	FE	<ul style="list-style-type: none"> <li>♦ Indoor unit has not been assigned an address.</li> </ul>

Notes:

Flashing rapidly means flashing twice per second; flashing slowly means flashing once per second.



MUNDO  CLIMA<sup>®</sup>



[www.mundoclima.com](http://www.mundoclima.com)

**ASK FOR MORE INFORMATION**

Phone: (+34) 93 446 27 80

eMail: [info@mundoclima.com](mailto:info@mundoclima.com)

**TECHNICAL ASSISTANCE**

Phone: (+34) 93 652 53 57