

# MONOBLOC AEROTHERM V17

Owner's & Installation manual

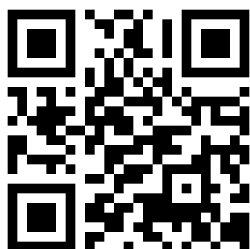
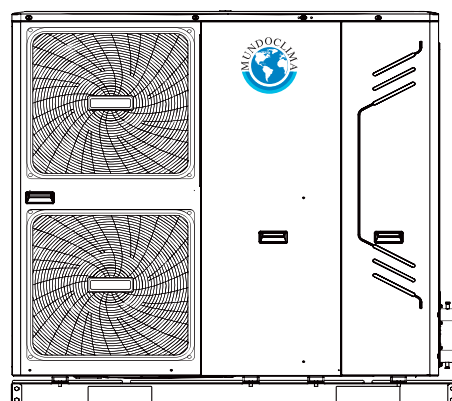

---

---

(Figure 1)

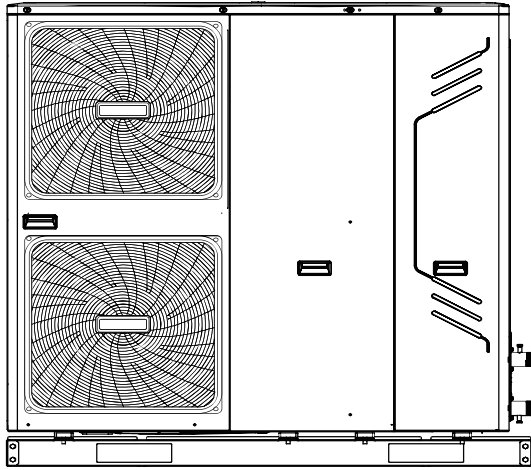

10/12/14/16 kW

(Figure 2)

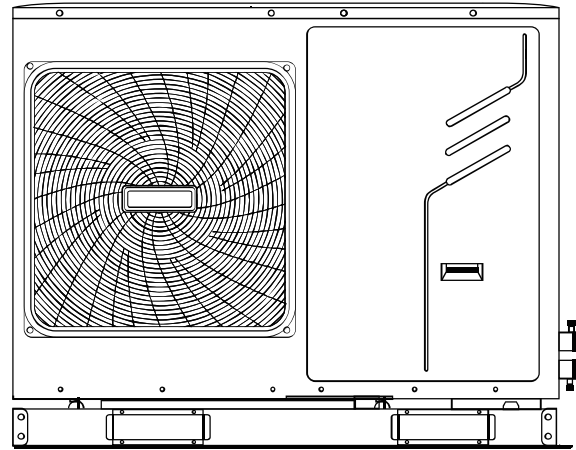

5/7 kW

Wiring diagram: 12-16kW(3-phase) for examples

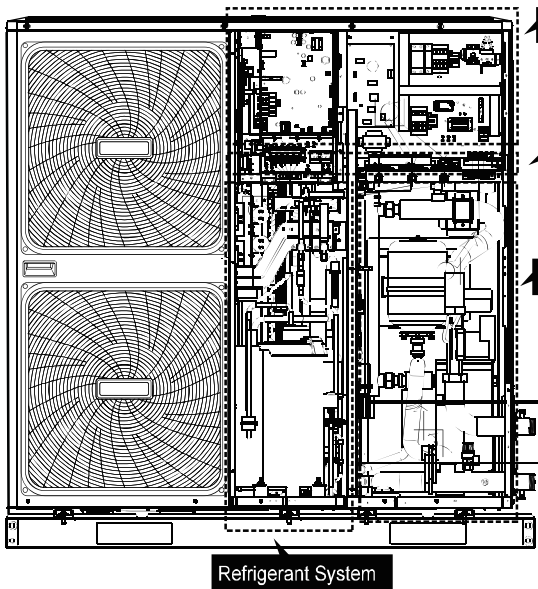

Electric Control System

Terminal Block

Hydraulic System

Refrigerant System

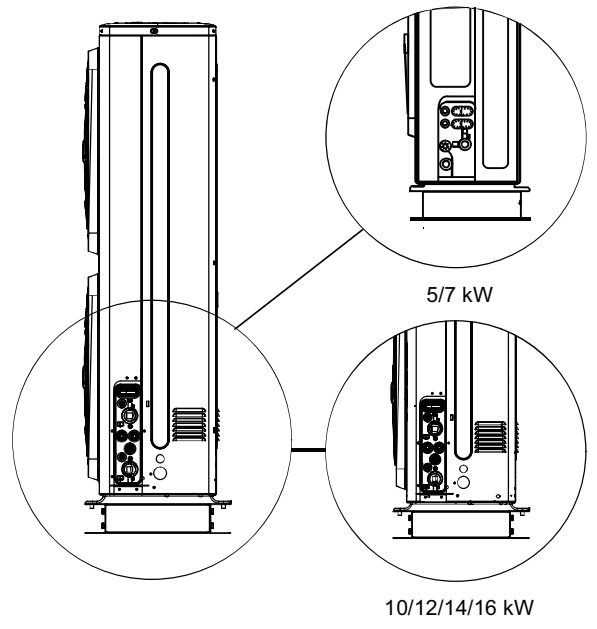

5/7 kW

10/12/14/16 kW

Please remove the hollow plate after installation.

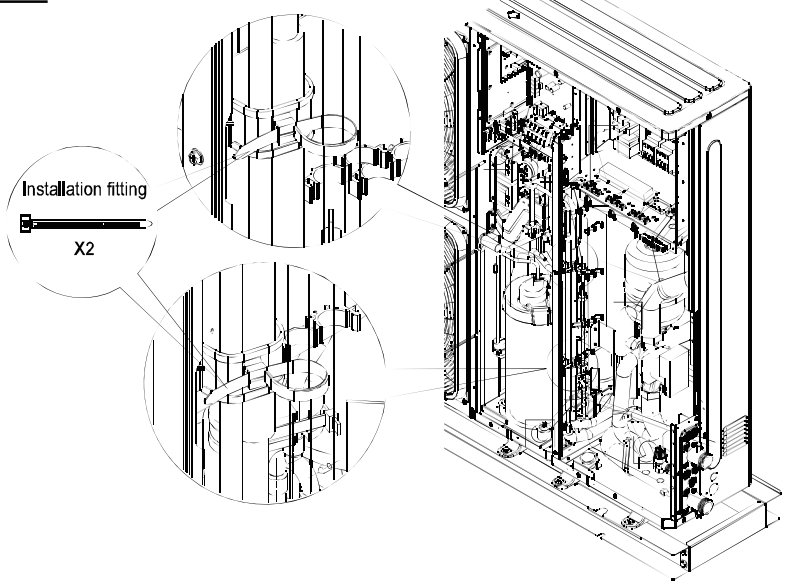
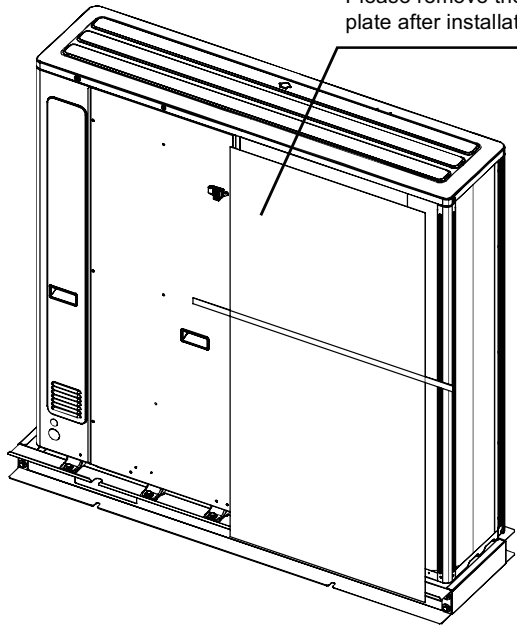

Installation fitting

X2

CONTENTS	PAGE
1 INTRODUCTION.....	3
2 ACCESSORIES.....	4
3 SAFETY CONSIDERATIONS.....	4
4 BEFORE INSTALLATION.....	5
5 IMPORTANT INFORMATION REGARDING THE REFRIGERANT USED.....	6
6 SELECTING INSTALLATION SITE.....	6
7 PRECAUTIONS ON INSTALLATION.....	7
8 TYPICAL APPLICATION EXAMPLES.....	9
9 OVERVIEW OF THE UNIT.....	20
10 START-UP AND CONFIGURATION.....	37
11 TEST RUN AND FINAL CHECK.....	50
12 MAINTENANCE AND SERVICE.....	50
13 TROUBLESHOOTING.....	50
14 PARAMETERS CHECK IN THE UNIT .....	52
15 TECHNICAL SPECIFICATIONS.....	56
ANNEX 1: WIRING DIAGRAM .....	57
ANNEX 2: TABLE FOR SERVICEMAN .....	60

## 1 INTRODUCTION

### 1.1 General information

- These units are used for both heating and cooling applications. They can be combined with fan coil units, floor heating applications, low temperature high efficiency radiators, domestic hot water tanks (optional) and solar kits (field supply).
- A wired remote controller is supplied with the unit to control the installation.
- The unit is delivered with an integrated backup heater for additional heating capacity during cold outdoor temperatures. The backup heater also serves as a backup in case of malfunctioning and for freeze protection of the outside water piping during winter time. The capacity of backup heater for different units is listed below.

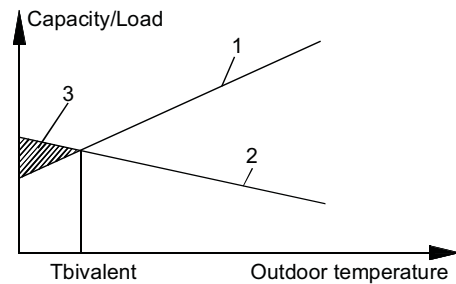

1. Heat pump capacity
2. Required heating capacity (site dependent)
3. Additional heating capacity provided by backup heater

Power supply	1-phase				3-phase					
	5 to 7kW		10 to 16kW		12 to 16kW					
Capacity of outdoor unit [kW]	5	7	10	12	14	16	12	14	16	
Capacity of backup heater	3.0kW				4.5kW					

#### ■ Domestic hot water tank (option)

An optional domestic hot water tank with integrated 3 kW electrical booster heater can be connected to the unit.

There is a heat change in the tank, if the heat exchange outside is enamelled, the heat exchange surface is required to be bigger than 1.7m<sup>2</sup> for matching the 10kW ~16kW unit and the heat exchanger surface is required to be bigger than 1.4m<sup>2</sup> for matching the 5kW~7kW unit.

#### ■ Room thermostat (field supply)

An optional room thermostat can be connected to the unit.

#### ■ Solar kit for domestic hot water tank (field supply)

An optional solar kit can be connected to the unit.

#### ■ Remote alarm kit (field supply)

A remote alarm kit can be connect to the unit.

#### ■ Operation range

Operating range of indoor unit	
Outlet water (Heating mode)	+25 ~ +60 °C
Outlet water (Cooling mode)	+5 ~ +25 °C
Domestic hot water	+40 ~ +60 °C
Ambient temperature	-20 ~ +46 °C
Water pressure	0.3~3bar(g)



READ THESE INSTRUCTIONS CAREFULLY BEFORE INSTALLATION. KEEP THIS MANUAL IN A HANDY PLACE FOR FUTURE REFERENCE.

IMPROPER INSTALLATION OR ATTACHMENT OF EQUIPMENT OR ACCESSORIES COULD RESULT IN ELECTRIC SHOCKS, SHORT-CIRCUITS, LEAKS, FIRE OR OTHER DAMAGE TO THE EQUIPMENT. BE SURE TO ONLY USE ACCESSORIES MADE BY THE SUPPLIER WHICH ARE SPECIFICALLY DESIGNED FOR USE WITH THE EQUIPMENT AND HAVE INSTALLATION DONE BY A PROFESSIONAL

ALL ACTIVITIES DESCRIBED IN THIS MANUAL SHALL BE CARRIED OUT BY A LICENSED TECHNICIAN.

BE SURE TO WEAR ADEQUATE PERSONAL PROTECTION SUCH AS GLOVES AND SAFETY GLASSES WHEN PERFORMING INSTALLATION, MAINTENANCE OR SERVICE TO THE UNIT.

IF UNSURE OF INSTALLATION PROCEDURES OR USE, CONTACT YOUR DEALER FOR GUIDANCE

■ No heat pump operation, backup heater or boiler only.











(\*) The models have a frozen prevention function using the heat pump and back up heater to keep the water system safe from freezing in all conditions. In case accidental or intentional power shutdown is likely to happen, we recommend to use glycol(-Refer to 9.3 Water pipework caution: "-Use of glycol).

1.2 Scope of this manual

This installation & owner's manual describes the procedures for installation.

2 ACCESSORIES

2.1 Accessories supplied with the unit

	NAME	SHAPE	QUANTITY	
			5~7kW	10~16kW
INSTALLATION FITTINGS	Outdoor unit installation & owner's manual(this book)		1	1
	Wire control owner's manual		1	1
	Y-shape filter		1	1
	Water outlet connection pipe assembly		2	1
	User interface kit(digital remote controller)		1	1
	Tighten belt for customer wiring use		0	2
			3	3
	T5:Thermistor for domestic hot water tank		1	1
	T1B:Thermistor for backup heater		1	0
Temperature sensor clamp		1	0	

3 SAFETY CONSIDERATIONS

The precautions listed here are divided into the following types. They are quite important, so be sure to follow them carefully.

Meanings of **DANGER**, **WARNING**, **CAUTION** and **NOTE** symbols.



**DANGER**

Indicates an imminently hazardous situation which if not avoided, will result in death or serious injury..



**WARNING**

Indicates a potentially hazardous situation which if not avoided, could result in death or serious injury.



**CAUTION**

Indicates a potentially hazardous situation which, if not avoided, may result in minor or moderate injury. It is also used to alert against unsafe practices.



**NOTE**

Indicates situations that could only result in accidental equipment or property damage.



**DANGER**

- Before touching electric terminal parts, turn off power switch.
- When service panels are removed, live parts can be easily touched by accident. Never leave the unit unattended during installation or servicing when the service panel is removed.
- Do not touch water pipes during and immediately after operation as the pipes may be hot and could burn your hand. To avoid injury, give the piping time to return to normal temperature or be sure to wear protective gloves.
- Do not touch any switch with wet fingers. Touching a switch with wet fingers can cause electrical shock.
- Before touching electrical parts, turn off all applicable power to the unit.



**WARNING**

- Tear apart and throw away plastic packaging bags so that children will not play with them. Children playing with plastic bags face danger of death by suffocation.
- Safely dispose of packing materials such as nails and other metal or wood parts that could cause injuries.
- Ask your dealer or qualified personnel to perform installation work in accordance with this manual. Do not install the unit yourself. Improper installation could result in water leakage, electric shocks or fire
- Be sure to use only specified accessories and parts for installation work. Failure to use specified parts may result in water leakage, electric shocks, fire, or the unit falling from its mount.

- Install the unit on a foundation that can withstand its weight.
- Insufficient physical strength may cause the equipment to fall and possible injury
- Perform specified installation work with full consideration of strong wind, hurricanes, or earthquakes. Improper installation work may result in accidents due to equipment falling.
- Make certain that all electrical work is carried out by qualified personnel according to the local laws and regulations and this manual using a separate circuit. Insufficient capacity of the power supply circuit or improper electrical construction may lead to electric shocks or fire.
- Be sure to install a ground fault circuit interrupter according to local laws and regulations. Failure to install a ground fault circuit interrupter may cause electric shocks and fire.
- Make sure all wiring is secure. Use the specified wires and ensure that terminal connections or wires are protected from water and other adverse external forces. Incomplete connection or affixing may cause a fire.
- When wiring the power supply, form the wires so that the front panel can be securely fastened. If the front panel is not in place there could be overheating of the terminals, electric shocks or fire.
- After completing the installation work, check to make sure that there is no refrigerant leakage.
- Never directly touch any leaking refrigerant as it could cause severe frostbite.
- Do not touch the refrigerant pipes during and immediately after operation as the refrigerant pipes may be hot or cold, depending on the condition of the refrigerant flowing through the refrigerant piping, compressor and other refrigerant cycle parts. Burns or frostbite are possible if you touch the refrigerant pipes. To avoid injury, give the pipes time to return to normal temperature or, if you must touch them be sure to wear protective gloves.
- Do not touch the internal parts (pump, backup heater, etc.) during and immediately after operation. Touching the internal parts can cause burns. To avoid injury, give the internal parts time to return to normal temperature or, if you must touch them, be sure to wear protective gloves.
- This appliance can be used by children 8 years old and above and persons with reduced physical, sensory or mental capabilities or lack of experience and knowledge if they are supervised or given instruction on using the unit in a safe manner and understand the hazards involved. Children should not play with the unit. Cleaning and user maintenance should not be done by children without supervision.



**CAUTION**

- When using units in applications with temperature alarm settings, it is advised to anticipate a delay of 10 minutes for an alarm signal when the alarm temperature is exceeded. The unit may stop for several minutes during normal operation for "defrosting of the unit" or during "thermostat-stop" operation.
- Ground the unit. Grounding resistance should be according to local laws and regulations. Do not connect the ground wire to gas or water pipes, lightning conductors or telephone ground wires. Incomplete grounding may cause electric shocks.



- a) Gas pipes. Fire or an explosion might occur if the gas leaks.
- b) Water pipes. Hard vinyl tubes are not effective grounds.
- c) Lightning conductors or telephone ground wires. Electrical threshold may rise abnormally if struck by a lightning bolt.
- Install the power wire at least 3 feet (1 meter) away from televisions or radios to prevent interference or noise. (Depending on the radio waves, a distance of 3 feet (1 meter) may not be sufficient to eliminate the noise.)
- Do not wash the unit. This may cause electric shocks or fire. The appliance must be installed in accordance with national wiring regulations. If the supply cord is damaged, it must be replaced by the manufacturer, its service agent or similarly qualified persons in order to avoid a hazard.
- Do not install the unit in the following places:
  - a) Where there is mist of mineral oil, oil spray or vapors. Plastic parts may deteriorate, and cause them to come loose or water to leak.
  - b) Where corrosive gases (such as sulphurous acid gas) are produced. Where corrosion of copper pipes or soldered parts may cause refrigerant to leak.
  - c) Where there is machinery which emits electromagnetic waves. Electromagnetic waves can disturb the control system and cause equipment malfunction.
  - d) Where flammable gases may leak, where carbon fiber or ignitable dust is suspended in the air or where volatile flammables such as paint thinner or gasoline are handled. These types of gases might cause a fire.
  - e) Where the air contains high levels of salt such as near the ocean.
  - f) Where voltage fluctuates a lot, such as in factories.
  - g) In vehicles or vessels.
  - h) Where acidic or alkaline vapors are present.

**4 BEFORE INSTALLATION**

**Before installation**

Be sure to confirm the model name and the serial number of the unit.

**Handling**

Due to relatively large dimensions and heavy weight, the unit should only be handled using lifting tools with slings. The slings can be fitted into foreseen sleeves at the base frame that are made specifically for this purpose.



**CAUTION**

- To avoid injury, do not touch the air inlet or aluminum fins of the unit.
- Do not use the grips in the fan grills to avoid damage.
- The unit is top heavy! Prevent the unit from falling due to improper inclination during handling.

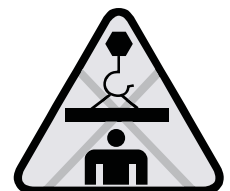

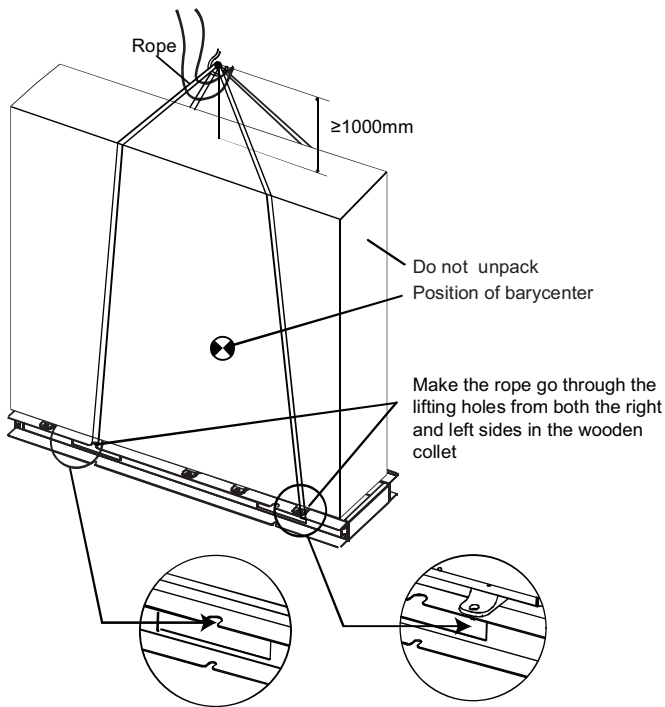

### 5 IMPORTANT INFORMATION REGARDING REFRIGERANT USED

This product contains fluorinated greenhouse gases covered by the Kyoto Protocol. Do not vent gases into the atmosphere.

Refrigerant type: R410A

GWP<sup>(1)</sup> value: 1975

(1) GWP = global warming potential

The refrigerant quantity is indicated on the unit name plate

### 6 SELECTING THE INSTALLATION SITE



#### WARNING

- Make sure to animal-proof the unit to keep out rodents and other small animals.
- Small animals making contact with electrical parts can cause malfunctions, smoke or fire. Please instruct the customer to keep the area around the unit clean.

- 1 Select an installation site where the following conditions are satisfied and one that meets with your customer's approval.
  - Places that are well-ventilated.
  - Places where the unit does not disturb next-door neighbors.
  - Safe places which can bear the unit's weight and vibration and where the unit can be installed at an even level.
  - Places where there is no possibility of flammable gas or product leak.
  - The equipment is not intended for use in a potentially explosive atmosphere.
  - Places where servicing space can be well ensured.
  - Places where the units' piping and wiring lengths come within the allowable ranges.
  - Places where water leaking from the unit cannot cause damage to the location (e.g. in case of a blocked drain pipe).
  - Places where rain can be avoided as much as possible.
  - Do not install the unit in places often used as a work space. In case of construction work (e.g. grinding etc.) where a lot of dust

- is created, the unit must be covered.
- dust is created, the unit must be covered.
- Do not place any objects or equipment on top of the unit (top plate)
- Do not climb, sit or stand on top of the unit.
- Be sure that sufficient precautions are taken in case of refrigerant leakage according to relevant local laws and regulations.

- 2 When installing the unit in a place exposed to strong wind, pay special attention to the following.
 

Strong winds of 5 m/sec or more blowing against the unit's air outlet causes a short circuit (suction of discharge air), and this may have the following consequences:

  - Deterioration of the operational capacity.
  - Frequent frost acceleration in heating operation.
  - Disruption of operation due to rise of high pressure.
  - When a strong wind blows continuously on the front of the unit, the fan can start rotating very fast until it breaks.

Refer to the figures for installation of this unit in a place where the wind direction can be foreseen.

- Turn the air outlet side toward the building's wall, fence or screen.

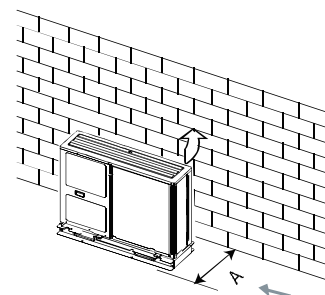

Unit	A(mm)
5-7kW	1000
10-16kW	1500

Make sure there is enough room to do the installation

- Set the outlet side at a right angle to the direction of the wind.

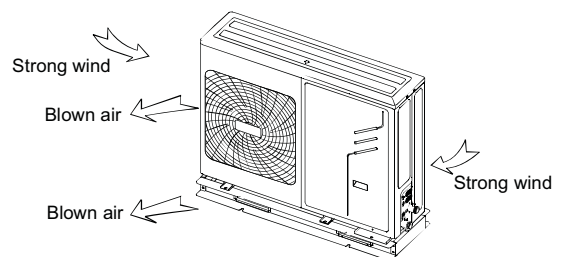

- 3 Prepare a water drainage channel around the foundation, to drain waste water from around the unit.
- 4 If water does not easily drain from the unit, mount the unit on a foundation of concrete blocks, etc. (the height of the foundation should be about 100 mm (3.93 in.).)
- 5 If you install the unit on a frame, please install a waterproof plate (about 100 mm) on the underside of the unit to prevent water from coming in from the low side.
- 6 When installing the unit in a place frequently exposed to snow, pay special attention to elevate the foundation as high as possible.

- 7 If you install the unit on a building frame, please install a waterproof plate (field supply) (about 100 mm.) on the underside of the unit in order to avoid drain water dripping. (See figure).

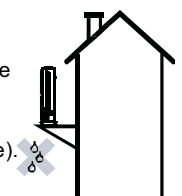





**NOTE**

Unit is top heavy!  
Try not to install on the building frame.

6.1 Selecting a location in cold climates

Refer to "Handling" in section "4 Before installation"



**NOTE**

When operating the unit in cold climates, be sure to follow the instructions described below.

- To prevent exposure to wind, install the unit with its suction side facing the wall.
- Never install the unit at a site where the suction side may be exposed directly to wind.
- To prevent exposure to wind, install a baffle plate on the air discharge side of the unit.
- In heavy snowfall areas it is very important to select an installation site where the snow will not affect the unit. If lateral snowfall is possible, make sure that the heat exchanger coil is not affected the snow (if necessary construct a lateral canopy).

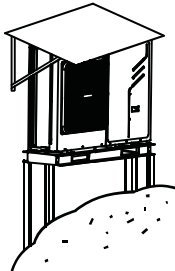

- 1 Construct a large canopy.
- 2 Construct a pedestal.  
Install the unit high enough off the ground to prevent it from being buried in snow.

6.2 Selecting a location in hot climates

As the outdoor temperature is measured via the outdoor unit air thermistor, make sure to install the outdoor unit in the shade, or a canopy should be constructed to avoid direct sunlight. so that it is not influenced by the sun's heat, otherwise protection may be possible to the unit.

**7 PRECAUTIONS ON INSTALLATION**

- Check the strength and level of the installation ground so that the unit will not cause any operating vibration or noise after installation.
- In accordance with the foundation drawing in the figure, fix the unit securely by means of the foundation bolts. (Prepare four sets each of  $\Phi 10$  Expansion bolts, nuts and washers which are readily available on the market.)
- It is best to screw in the foundation bolts until their length is 20 mm from the foundation surface.

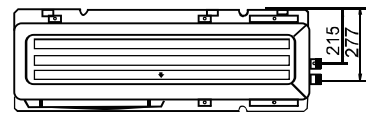
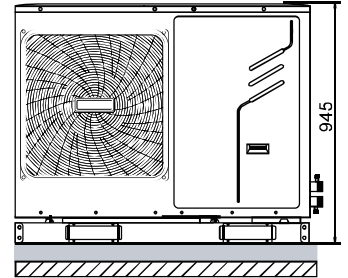
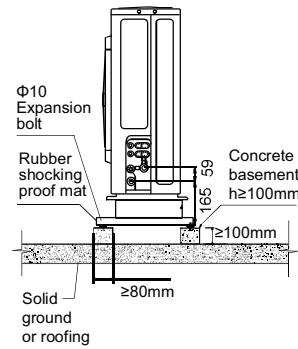
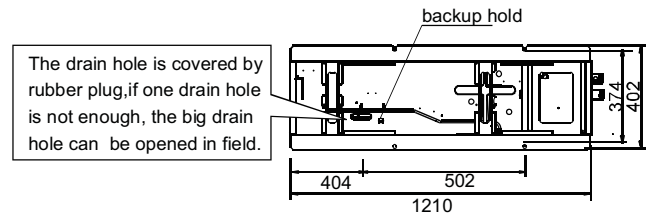

5/7 kW

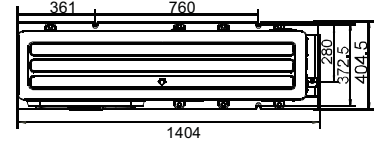
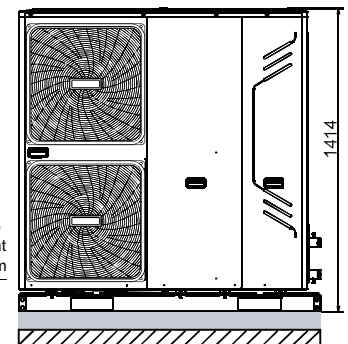
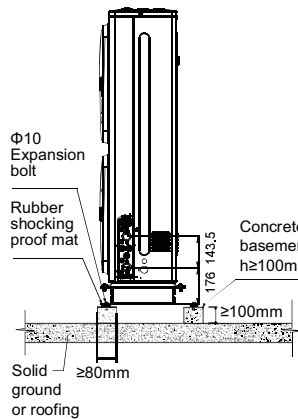
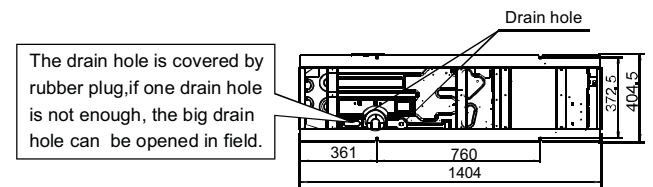

10/12/14/16 kW



**NOTE**

If drain holes in the unit are covered by a mounting base or by floor surface, raise the unit in order to provide a free space of more than 100 mm under the unit.



7.1 Installation servicing space

(A) In case of stacked installation

1. In case obstacles exist in front of the outlet side.

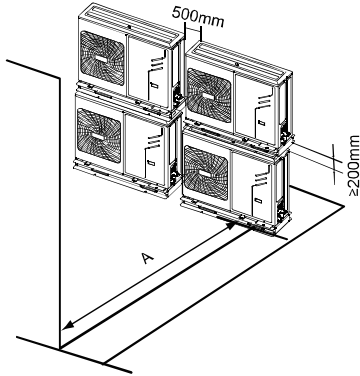

Unit	A(mm)
5-7kW	1000
10-16kW	1500

(B) In case of multiple-row installation (for roof top use, etc.)

1. In case of installing one unit per row.

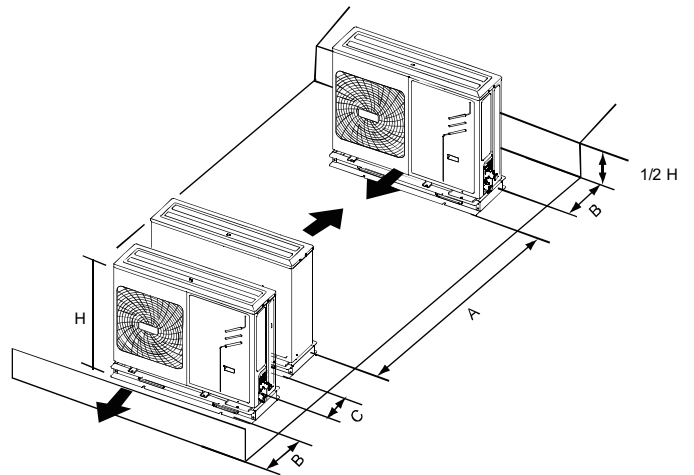

Unit	A(mm)	B(mm)	C(mm)
5-7kW	1500	500	300
10-16kW	2000	1000	300

2. In case obstacles exist in front of the air inlet.

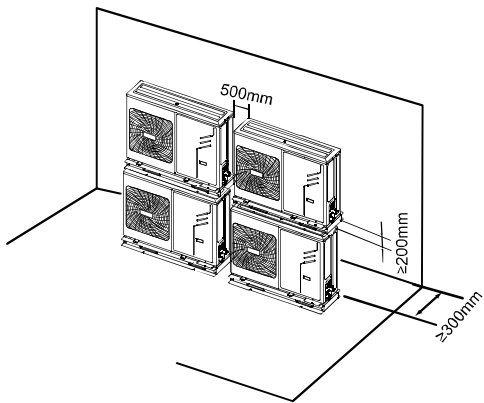

2. In case of installing multiple units (2 units or more) in lateral connection per row.

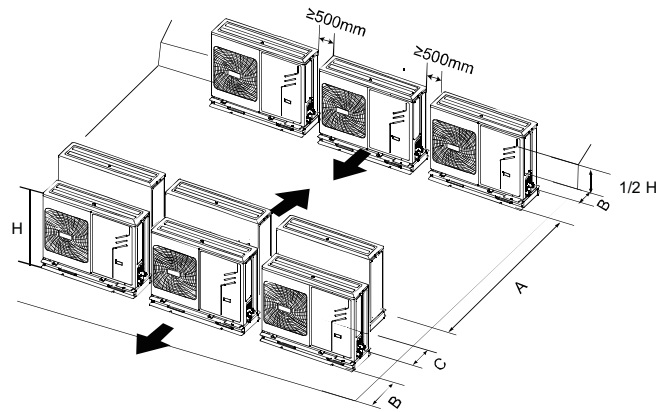

Unit	A(mm)	B(mm)	C(mm)
5-7kW	2000	500	300
10-16kW	2500	1000	300

## 8 TYPICAL APPLICATION EXAMPLES

The application examples given below are for illustration purposes only.

### 8.1 Application 1

Space heating only application with a room thermostat connected to the unit.

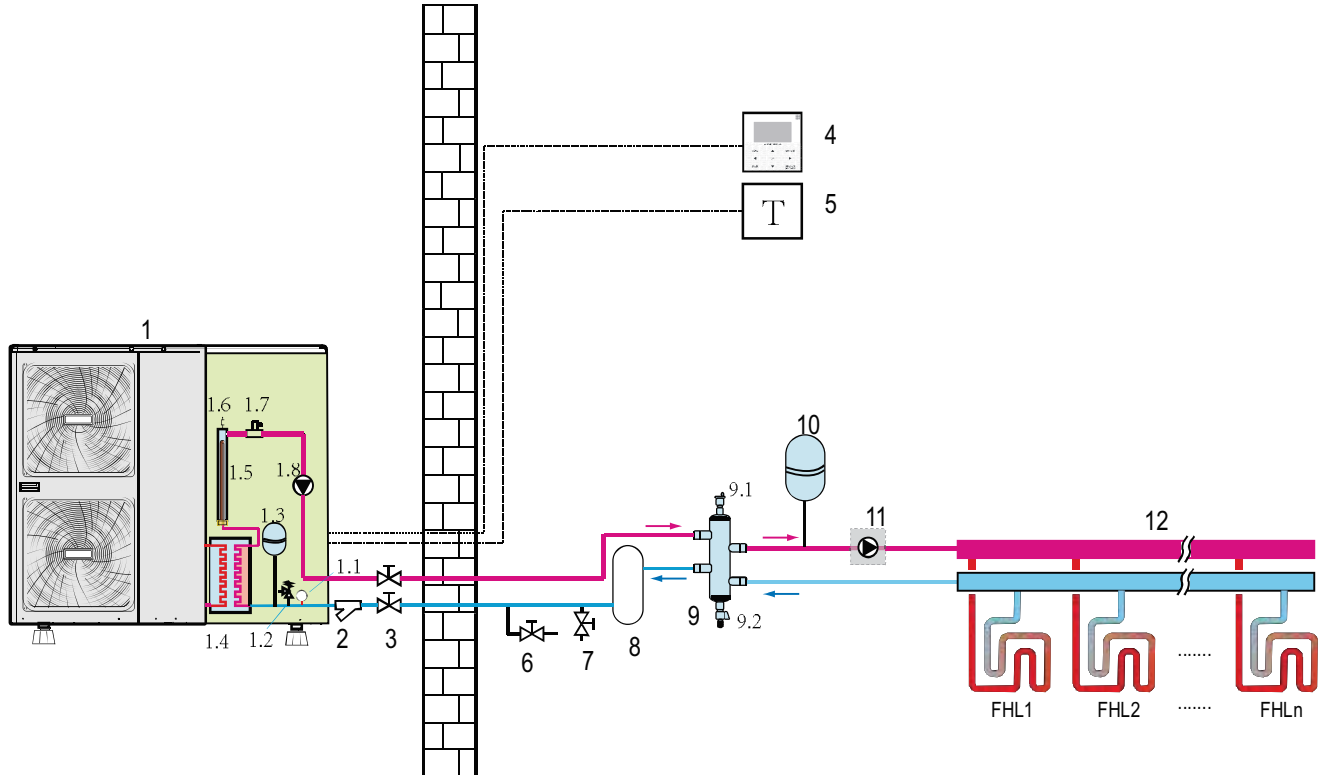

- |                                  |   |
|----------------------------------|---|
| 1 outdoor unit                   | 5 room thermostat (field supply)                |
| 1.1 manometer                    | 6 drain valve (field supply)                    |
| 1.2 pressure relief valve        | 7 fill valve (field supply)                     |
| 1.3 expansion vessel             | 8 buffer tank (field supply)                    |
| 1.4 plate heat exchanger         | 9 balance tank (field supply)                   |
| 1.5 backup heater                | 9.1 air purge valve                             |
| 1.6 air purge valve              | 9.2 drain valve                                 |
| 1.7 flow switch                  | 10 expansion vessel (field supply)              |
| 1.8 P_i: Inside circulation pump | 11 P_o: Outside circulation pump (field supply) |
| 2 y-shape filter                 | 12 collector (field supply)                     |
| 3 stop valve (field supply)      | FHL 1...n floor heating loop                    |
| 4 user interface                 |   |



### NOTE

The volume of the buffer tank (8) should be larger than 30 L (7.92 gallons). The drain valve (6) should be installed at the lowest position of the system. For the 5/7kw unit, the backup heater (1.5) is not integrated in the outdoor unit. An independent backup heater can be selected and installed in the door.

### Unit operation and space heating

When a room thermostat is connected to the unit and when there is a heating request from the room thermostat, the unit will start operating to achieve the target water flow temperature as set on the user interface. When the room temperature is above the thermostat set point in the heating mode, the unit will stop operating. The circulation pump (1.8) and (11) will also stop running. The room thermostat is used as a switch here.



### NOTE

Make sure to connect the thermostat wires to the correct terminals, method B should be selected (see **"For room thermostat"** in 9.6.6 connection for other components). To correctly configure the ROOM THERMOSTAT in the **FOR SERVICEMAN** mode see 10.7 Field settings/ROOM THERMOSTAT.

8.2 Application 2

On the unit, the side for space heating is not connected to a room thermostat. The temperature in each room is controlled by a valve on each water circuit. Domestic hot water is provided through the domestic hot water tank that is connected to the unit.

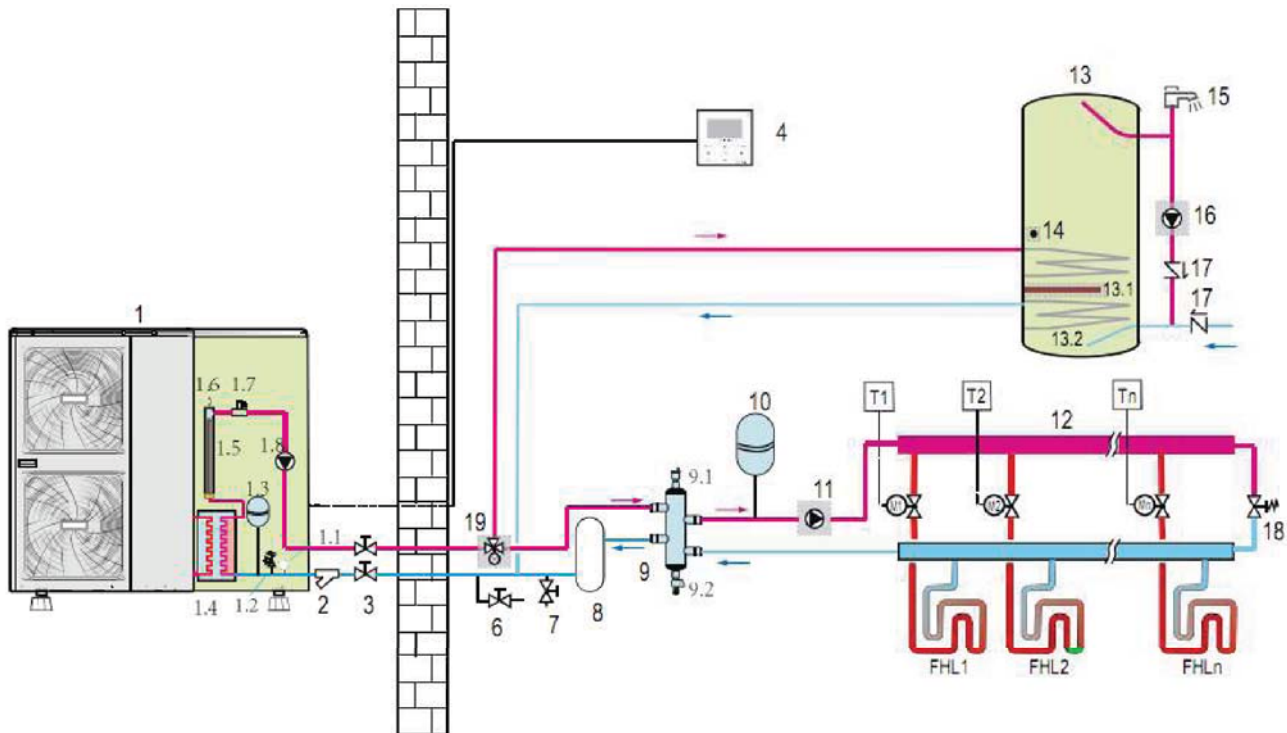

- |   |   |                                       |
|---|---|---------------------------------------|
| 1 outdoor unit                            | 4 user interface                                | 13.1 booster heater                   |
| 1.1 manometer                             | 6 drain valve (field supply)                    | 13.2 heat exchanger coil              |
| 1.2 pressure relief valve                 | 7 fill valve (field supply)                     | 14 T5: temperature sensor             |
| 1.3 expansion vessel                      | 8 buffer tank (field supply)                    | 15 hot water tap (field supply)       |
| 1.4 plate heat exchanger                  | 9 balance tank (field supply)                   | 16 P_d: DHW pump (field supply)       |
| 1.5 backup heater                         | 9.1 air purge valve                             | 17 non-return valve (field supply)    |
| 1.6 air purge valve                       | 9.2 drain valve                                 | 18 bypass valve (field supply)        |
| 1.7 flow switch                           | 10 expansion vessel (field supply)              | 19 SV1: 3-way valve (field supply)    |
| 1.8 P_i: circulation pump inside the unit | 11 P_o: outside circulation pump (field supply) | FHL 1...n floor heating loop          |
| 2 y-shape filter                          | 12 collector (field supply)                     | M1...n motorized valve (field supply) |
| 3 stop valve (field supply)               | 13 domestic hot water tank (field supply)       | T1...n room thermostat (field supply) |



**NOTE**

The total volume of balance tank and buffer tank should larger than 30L.  
 If the volume of balance tank(9) larger than 30L, the buffer tank(8) is unnecessary, otherwise the buffer tank(8) should be installed and the total volume of balance tank and buffer tank should larger than 30L. The drain valve (6) should be installed at the lowest position of the system. For 5/7kW unit, the backup heater (1.5) is not integrated in the outdoor unit. An independent backup heater can be selected and installed in the door.

■ **Circulation pump operation**

With no room thermostat connected to the unit (1) the circulation pump (1.8) and (11) will operate as long as the unit is on for space heating. The circulation pump (1.8) will operate as long as the unit is on for heating domestic hot water (DHW).

■ **Space heating**

- 1) The unit (1) will operate to achieve the target water flow temperature set on the user interface.
- 2) When the circulation in each space heating loop (FCU1...n) is controlled by remote controlled valves (M1...n), it is important to provide a bypass valve (18) to ensure that the flow switch safety device is not activated.  
 The bypass valve should be selected so that at all times the minimum water flow as mentioned in **9.3 Water pipework** is guaranteed.

■ **Domestic water heating**

- 1) When the domestic water heating mode is enabled (either manually by the user, or automatically through scheduling) the target domestic hot water temperature will be achieved by a combination of the heat exchanger coil and the electrical booster heater (when the booster heater in the tank is set to YES).
- 2) When the domestic hot water temperature is below the user configured set point, the 3-way valve will be activated to heat the domestic water by means of the heat pump. If there is a huge demand for hot water or a high hot water temperature setting, the booster heater (13.1) can provide auxiliary heating.



**CAUTION**

Make sure to fit the 3-way valve correctly. For more details, refer to **9.6.6 Connection for other components/For 3-way valve SV1**.



**NOTE**

The unit can be configured so that at low outdoor temperatures, water is exclusively heated by the booster heater. This assures that the full capacity of the heat pump is available for space heating.

Details on domestic hot water tank configuration for low outdoor temperatures (T4DHWMIN) can be found in **10.7 Field settings/How to set the DHW MODE**.

**8.3 Application 3**

Space cooling and heating application with a **room thermostat suitable for heating/cooling changeover** when connected to the unit. Heating is provided through floor heating loops and fan coil units. Cooling is provided through the fan coil units only. Domestic hot water is provided through the domestic hot water tank which is connected to the unit.

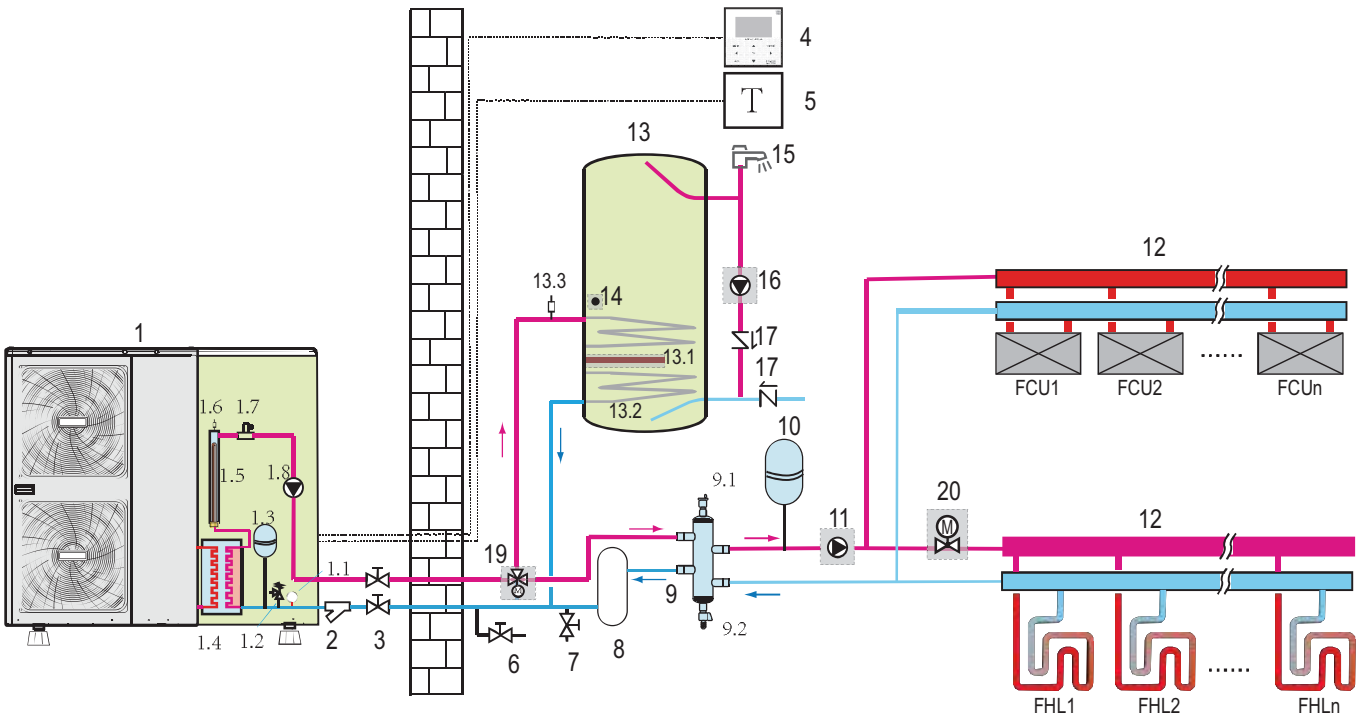

- |   |   |
|---|---|
| 1 outdoor unit                            | 9 balance tank (field supply)                 |
| 1.1 manometer                             | 9.1 air purge valve                           |
| 1.2 pressure relief valve                 | 9.2 drain valve                               |
| 1.3 expansion vessel                      | 10 expansion vessel (field supply)            |
| 1.4 plate heat exchanger                  | 11 P_o: outside circulate pump (field supply) |
| 1.5 backup heater                         | 12 collector (field supply)                   |
| 1.6 air purge valve                       | 13 domestic hot water tank (field supply)     |
| 1.7 flow switch                           | 13.1 booster heater                           |
| 1.8 P_i: circulation pump inside the unit | 13.2 heat exchanger coil                      |
| 2 y-shape filter                          | 14 T5:temperature sensor                      |
| 3 stop valve (field supply)               | 15 hot water tap (field supply)               |
| 4 user interface                          | 16 P_d: DHW pipe pump (field supply)          |
| 5 room thermostat (field supply)          | 17 non-return valve (field supply)            |
| 6 drain valve (field supply)              | 19 SV1: 3-way valve (field supply)            |
| 7 fill valve (field supply)               | 20 SV2: 2-way valve (field supply)            |
| 8 buffer tank (field supply)              | FHL 1...n floor heating loop                  |
|   | FCU 1...n fan coil units                      |



**NOTE**

If the volume of balance tank(9) larger than 30L, the buffer tank(8) is unnecessary, otherwise the buffer tank(8) should be installed and the total volume of balance tank and buffer tank should larger than 30L. The drain valve(6) should be installed at the lowest position of the system.

■ **Pump operation and space heating and cooling**

According to the season, the unit will switch to either heating or cooling mode according to the temperature detected by the room thermostat. Wiring of the room thermostat should follow **method A** as described in **9.6.6 connection for other components/For room thermostat**.

When space heating/cooling is requested by the room thermostat (5), the pump will start operating and the unit (1) will switch to heating mode/cooling mode. The unit (1) will start operating to achieve the target cold/hot water leaving temperature.

In the cooling mode, the motorized 2-way valve (20) will close to prevent cold water running through the floor heating loops (FHL).

**CAUTION**

- Make sure to connect the thermostat wires are routed to the correct terminals and to configure the ROOM THERMOSTAT in the user interface correctly (see **10.7 Field settings/ROOM THERMOSTAT**). Wiring of the room thermostat should follow **method A** as described in **9.6.6 connection for other components/For room thermostat**.
- Wiring of the 2-way valve (20) is different for a NC (normal closed) valve and a NO (normal open) valve! Make sure to connect to the correct terminal numbers as detailed on the wiring diagram.

The ON/OFF setting of the heating/cooling operation cannot be done on the user interface.

■ Domestic water heating

Domestic water heating is as described in **8.2 Application 2**.

**8.4 Application 4**

Space cooling and heating application without a room thermostat connected to the unit, but with heating/cooling thermostat controlling the fan coil units. Heating is provided through floor heating loops and fan coil units. Cooling is provided through the fan coil units only.

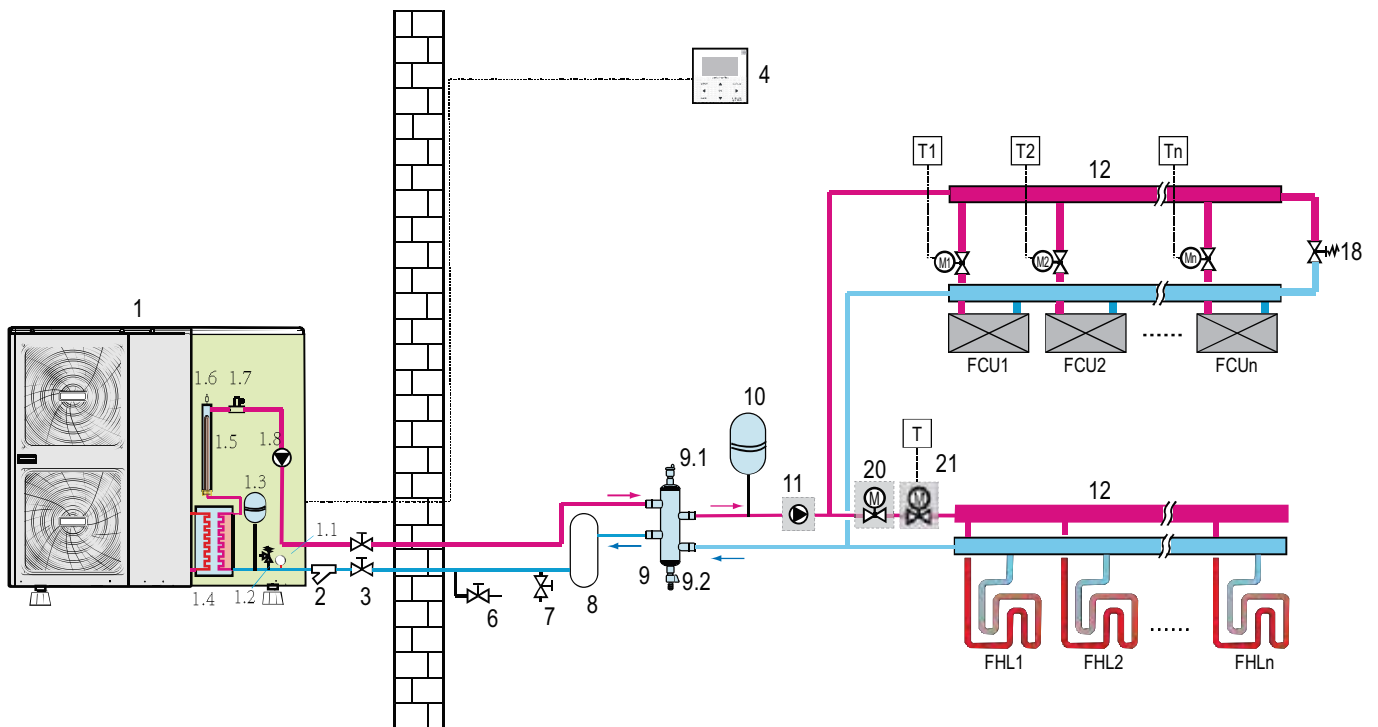

- |                                       |   |  |
|---------------------------------------|---|--|
| 1 outdoor unit                        | 3 stop valve (field supply)                   | 12 collector (field supply)            |
| 1.1 manometer                         | 4 user interface                              | 18 bypass valve (field supply)         |
| 1.2 pressure relief valve             | 6 drain valve (field supply)                  | 20 SV2: 2-way valve (field supply)     |
| 1.3 expansion vessel                  | 7 fill valve (field supply)                   | 21 Motorized 2-wayvalve (field supply) |
| 1.4 plate heat exchanger              | 8 buffer tank (field supply)                  | FHL 1...n floor heating loop           |
| 1.5 backup heater                     | 9 balance tank (field supply)                 | FCU 1...n fan coil units               |
| 1.6 air purge valve                   | 9.1 air purge valve                           | M1...n motorized valve (field supply)  |
| 1.7 flow switch                       | 9.2 drain valve                               | T1...n room thermostat (field supply)  |
| 1.8 P_i: circulation pump in the unit | 10 expansion vessel (field supply)            |  |
| 2 y-shape filter                      | 11 P_o: outside circulate pump (field supply) |  |

**NOTE**

If the volume of balance tank(9) larger than 30L, the buffer tank(8) is unnecessary, otherwise the buffer tank(8) should be installed and the total volume of balance tank and buffer tank should larger than 30L. The drain valve (6) should be installed at the lowest position of the system. For 5/7kW unit, the backup heater (1.5) is not integrated in the outdoor unit. An independent backup heater can be selected and installed in the door.

---

**Pump operation**

With no room thermostat connected to the unit (1), the circulation pump (1.8) and (11) will operate as long as the unit is on for space heating. The pump (1.8) will operate as long as the unit is on for heating domestic hot water.

---

**NOTE**

Details on pump configuration can be found in **10.5 setting the pump speed**.

---

**Space heating and cooling**

According to the season, the customer selects cooling or heating through the user interface.

The unit (1) will operate in cooling mode or heating mode to achieve the target water flow temperature.

In heating mode, the 2-way valve (20) is open. Hot water is provided to both the fan coil units and the floor heating loops.

In cooling mode, the motorized 2-way valve (20) is closed to prevent cold water running through the floor heating loops (FHL).

---

**CAUTION**

When several loops in the system are near remotely controlled valves, it might be required to install a bypass valve (18) to avoid the flow switch safety device from being activated. See also **8.2 Application 2**.

Wiring of the 2-way valve (20) is different for a NC (normal closed) valve and a NO (normal open) valve. The NO valve is unavailable to this unit. Make sure to connect to the correct terminal numbers as detailed on the wiring diagram.

---

The ON/OFF setting of the heating/cooling operation is done by the user interface.

**8.5 Application 5**

Space heating with an auxiliary boiler (alternating operation).

Space heating application by either the unit or by an auxiliary boiler connected in the system.

- The unit controlled contact (also called 'permission signal for the auxiliary boiler") is determined by the outdoor temperature (thermistor located at the outdoor unit). See **10.7 Field settings/OTHER HEATING SOURCE**
  - Bivalent operation is possible for both space heating operation and domestic water heating operation.
  - If the auxiliary boiler only provides heating for space heating, the boiler must be integrated in the piping work and in the field wiring according to the illustration for **application a**.
  - If the auxiliary boiler is also providing heating for domestic hot water, the boiler can be integrated in the piping work and in the field wiring according to the illustration for **application b**.
  - **Application C** can be used If the temperature of water from unit is not high enough. An additional 3-way valve should be installed, if the temperature of water from unit is high enough. The boiler will then be bypassed. When the temperature is not high enough, the 3-way valve will open and the water from unit will flow through the boiler and be heated again.
-

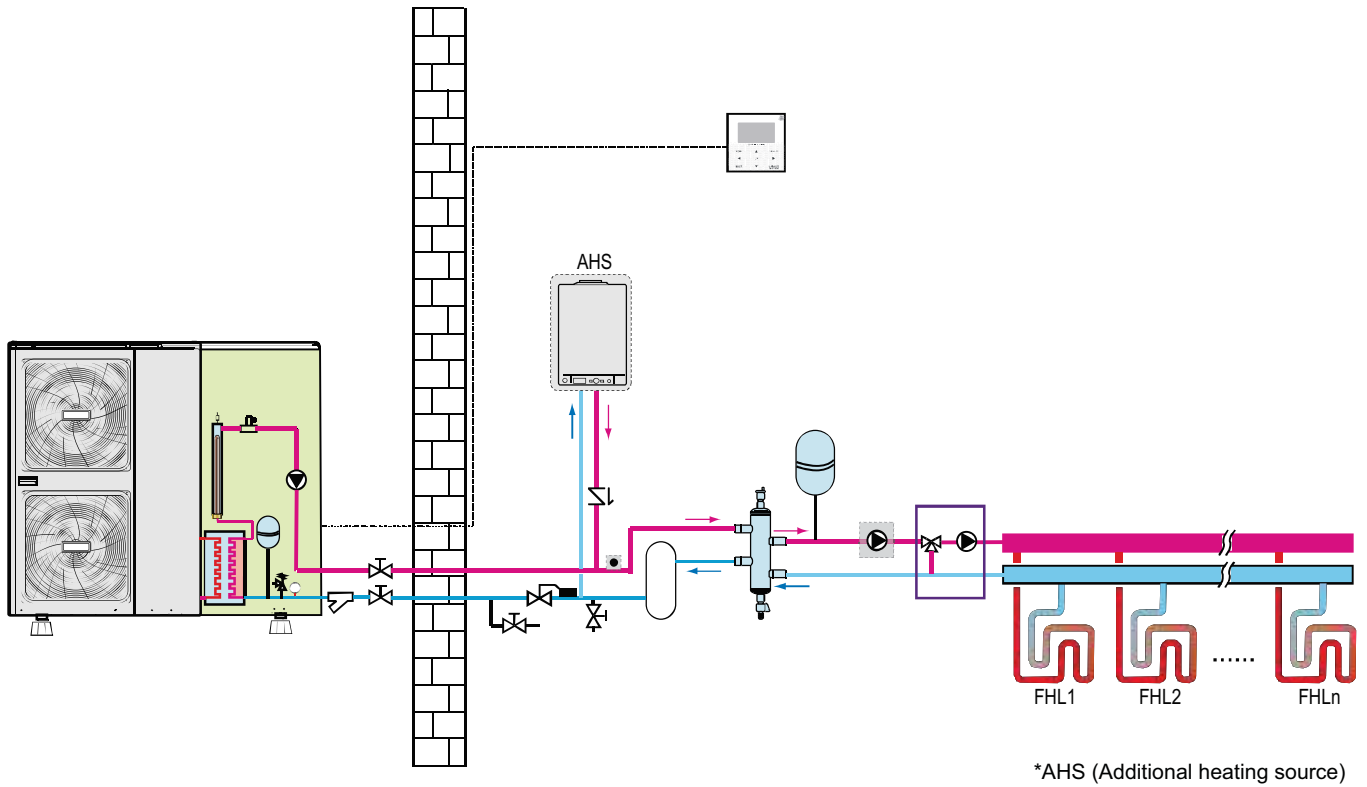

**CAUTION**

Be sure that the boiler and the integration of the boiler in the system is in accordance with relevant local laws and regulations.

Application A

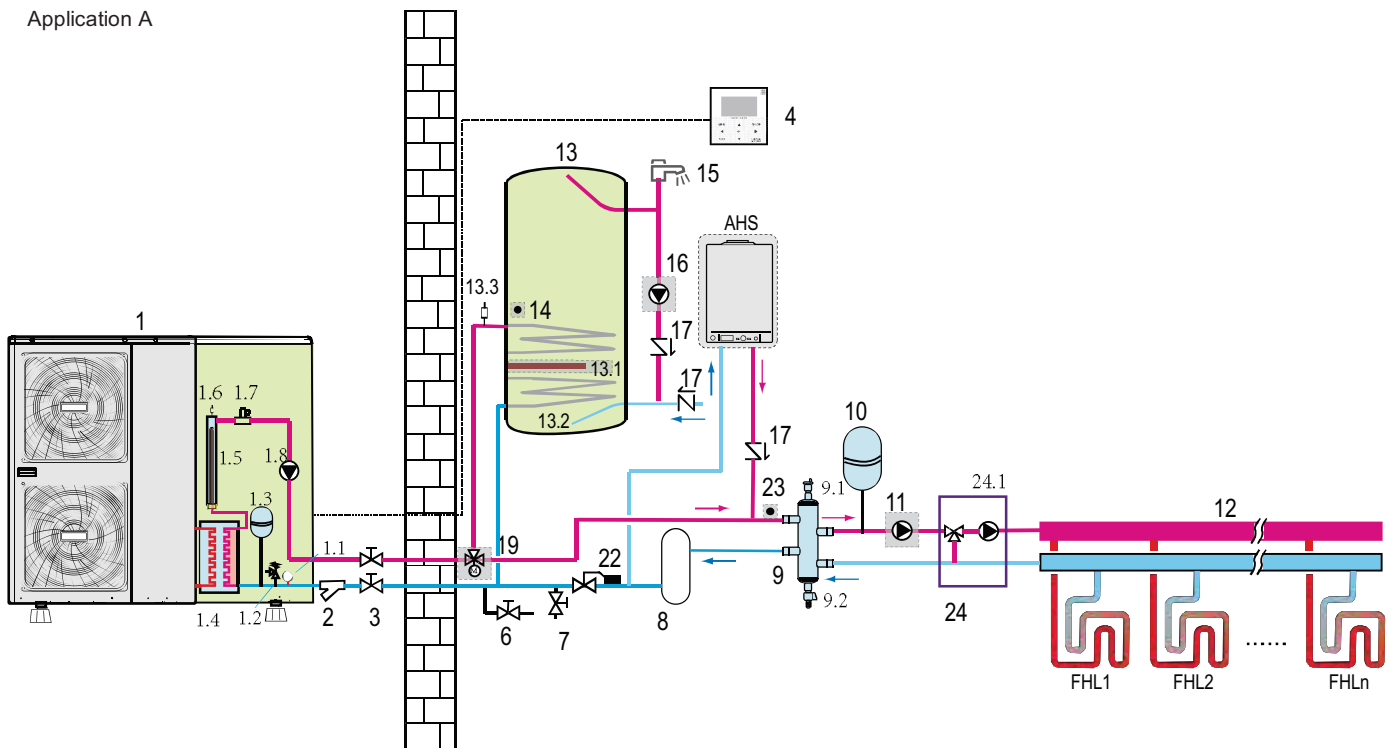



Application B

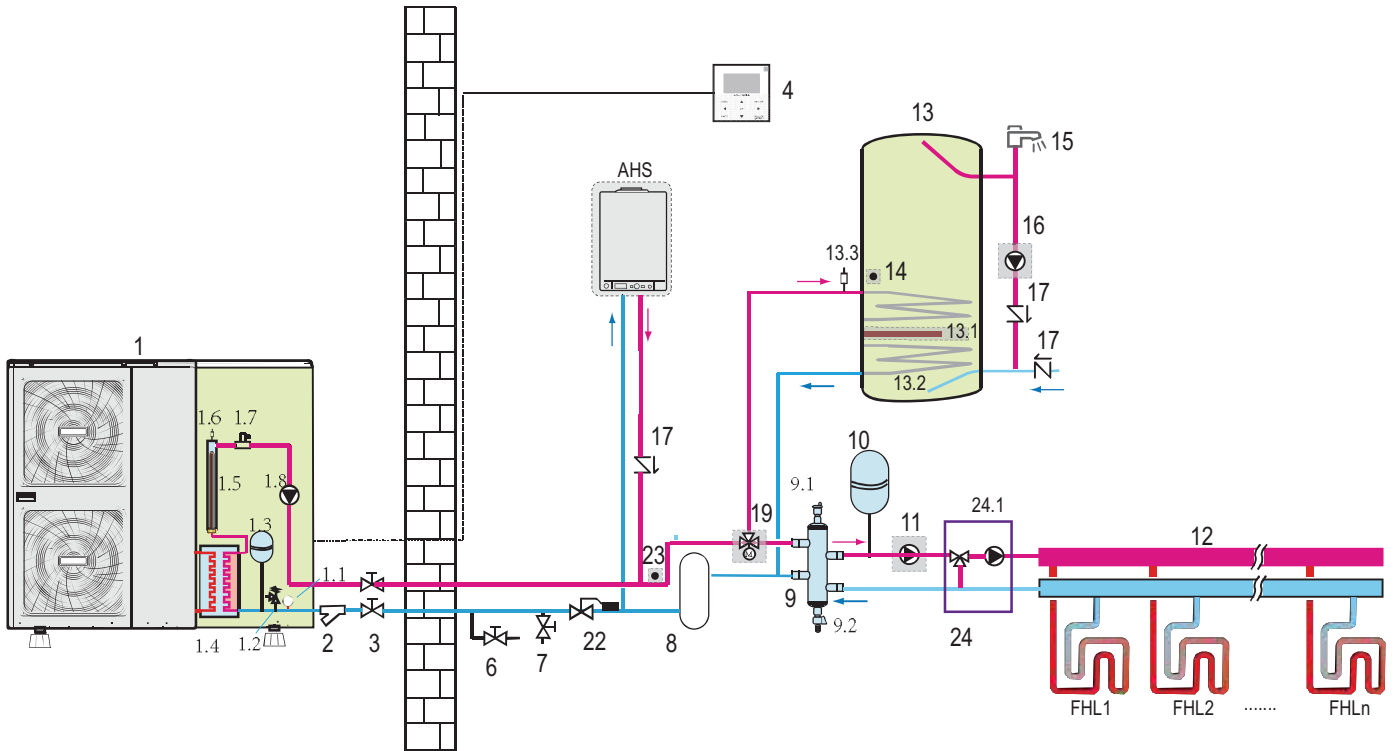

Application C

If application C is selected, the control cable connect to the boiler should also connect to the 3-way valve (25)

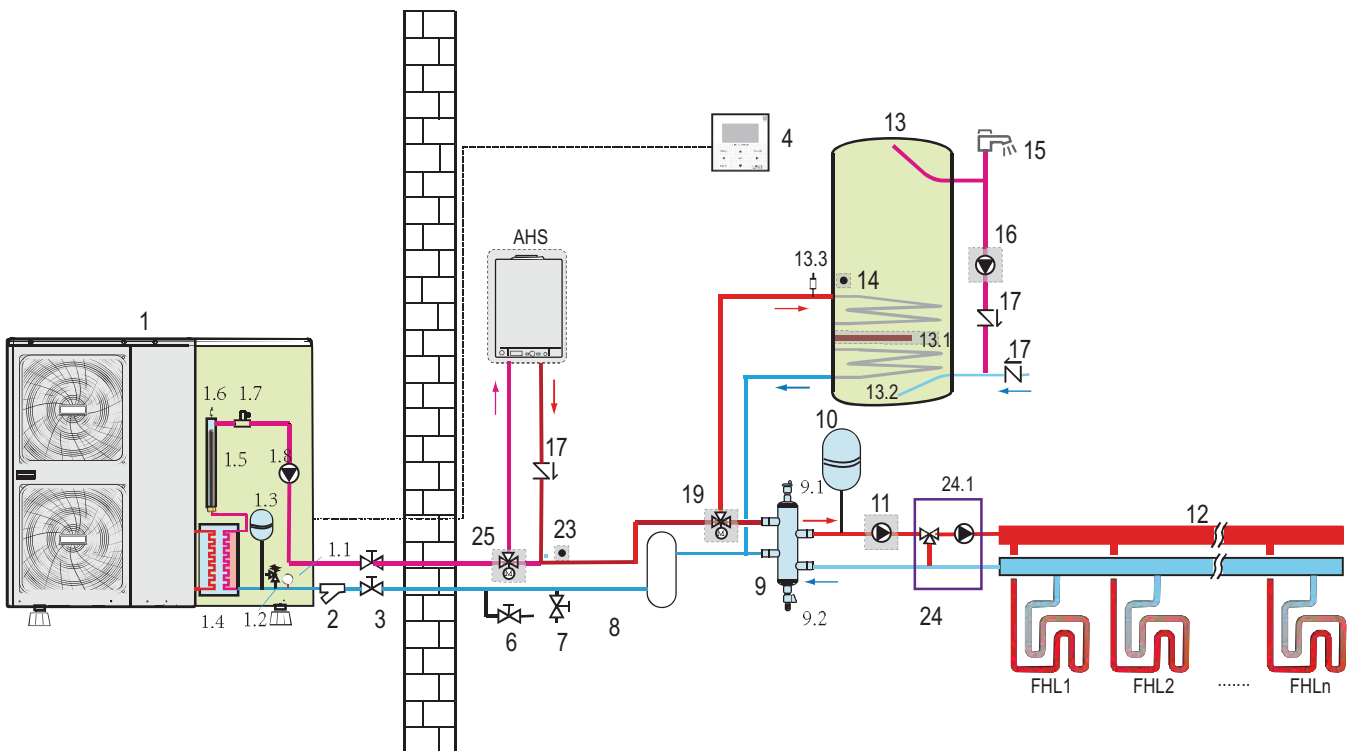

1 outdoor unit	8 buffer tank(field supply)	16 P_d: DHW pump(field supply)
1.1 manometer	9 balance tank(field supply)	17 non-return valve(field supply)
1.2 pressure relief valve	9.1 air purge valve	19 SV1: 3-way valve(field supply)
1.3 expansion vessel	9.2 drain valve	22 aquastat valve(field supply)
1.4 plate heat exchanger	10 expansion vessel(field supply)	23 T1B: temperature sensor(field supply)
1.5 backup heater	11 P_o: outside circulation pump (field supply)	24 mixing station(field supply)
1.6 air purge valve	12 collector(field supply)	24.1 P_c: mixing pump
1.7 flow switch	13 domestic hot water tank(field supply)	25 3-way valve(field supply)
1.8 P_i: circulation pump inside the unit	13.1 booster heater	FHL 1...n floor heating loop
2 y-shape filter	13.2 heat exchanger coil	AHS additional heating source(boiler)
3 stop valve (field supply)	14 T5:temperature sensor	
4 user interface	15 hot water tap(field supply)	
6 drain valve(field supply)		
7 fill valve(field supply)		



### NOTE

If the volume of balance tank(9) larger than 30L, the buffer tank(8) is unnecessary, otherwise the buffer tank(8) should be installed and the total volume of balance tank and buffer tank should larger than 30L.. The drain valve (6) should be installed at the lowest position of the system. For the 5/7kW unit, the backup heater (1.5) is not integrated in the outdoor unit. An independent backup heater can be selected and installed in the door.

### Operation

When heating is required, either the unit or the boiler starts operating, depending on the outdoor temperature (refer to **10.7 field setting/OTHER HEATING SOURCE**).

- As the outdoor temperature is measured via the outdoor unit air thermistor, make sure to install the outdoor unit in the shade, so that it is not influenced by the sun's heat.
- Frequent switching can cause corrosion of the boiler at an early stage. Contact the boiler manufacturer.
- During heating operation of the unit, the unit will operate to achieve the target water flow temperature set on the user interface. When weather dependent operation is active, the water temperature is determined automatically depending on the outdoor temperature.
- During heating operation of the boiler, the boiler will operate to achieve the target water flow temperature set on the user interface.
- Never set the target water flow temperature set point on the user interface above (60°C).



### NOTE

Make sure to correctly configure FOR SERVICEMAN in the user interface. Refer to **10.7 Field settings/Other heating source**.



### CAUTION

- Ensure that return water to the heat exchanger does not exceed 60°C. Never put the target water flow temperature set point on the user interface above 60°C.
- Make sure that the non-return valves (field supply) are correctly installed in the system.
- The supplier will not be held liable for any damage resulting from failure to observe this rule.

## 8.6 Application

- Space heating with a two room thermostat application through floor heating loops and fan coil units. The floor heating loops and fan coil units require different operating water temperatures.
- The floor heating loops require a lower water temperature in heating mode compared to fan coil units. To achieve these two set points, a mixing station is used to adapt the water temperature according to requirements of the floor heating loops. The fan coil units are directly connected to the unit water circuit and the floor heating loops are after the mixing station. Control of this mixing station is not done by the unit.
- The operation and configuration of the field water circuit is the responsibility of the installer.
- We only offer a dual set point control function. This function allows two set points to be generated. Depending on the required water temperature (floor heating loops and/or fan coil units are required) the first set point or second set point can be activated. See **10.7 field setting /ROOM THERMOSTAT**.

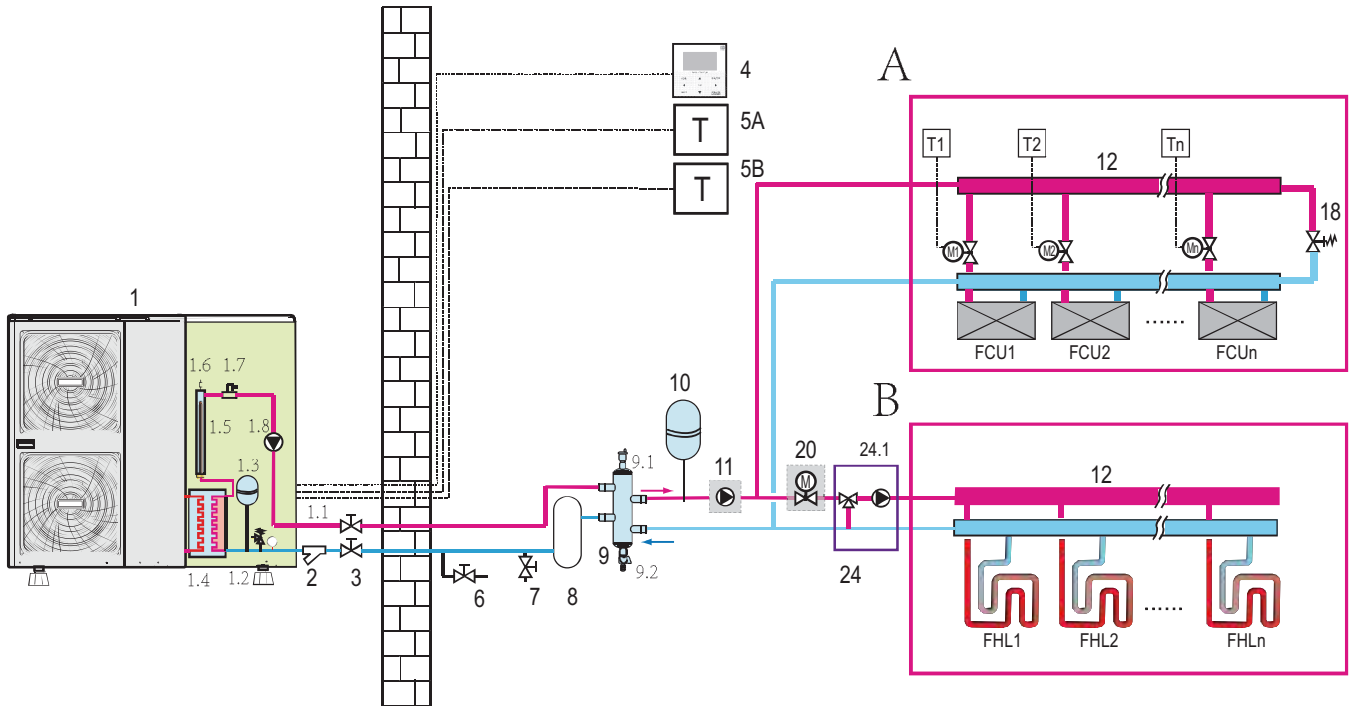

- |   |   |
|---|---|
| 1 outdoor unit                                    | 9 balance tank (field supply)                               |
| 1.1 manometer                                     | 9.1 air purge valve   |
| 1.2 pressure relief valve                         | 9.2 drain valve   |
| 1.3 expansion vessel                              | 10 expansion vessel (field supply)                          |
| 1.4 plate heat exchanger                          | 11 P <sub>o</sub> : outside circulation pump (field supply) |
| 1.5 backup heater                                 | 12 collector (field supply)                                 |
| 1.6 air purge valve                               | 18 bypass valve (field supply)                              |
| 1.7 flow switch                                   | 20 SV2:2-way valve (field supply)                           |
| 1.8 P <sub>i</sub> : circulation pump in the unit | 24 mixing station (field supply)                            |
| 2 y-shape filter                                  | 24.1 P <sub>c</sub> : mixing pump                           |
| 3 stop valve (field supply)                       | FHL 1...n floor heating loop                                |
| 4 user interface                                  | FCU 1...n fan coil units                                    |
| 6 drain valve (field supply)                      | M1...n motorized valve (field supply)                       |
| 7 fill valve (field supply)                       | T1...n room thermostat (field supply)                       |
| 8 buffer tank (field supply)                      |   |



**NOTE**

If the volume of balance tank(9) larger than 30L, the buffer tank(8) is unnecessary, otherwise the buffer tank(8) should be installed and the total volume of balance tank and buffer tank should larger than 30L. The drain valve (6) should be installed at the lowest position of the system. For the 5/7kW unit, the backup heater (1.5) is not integrated in the outdoor unit. An independent backup heater can be selected and installed in the door. The advantage of the dual set point control is that the heat pump will/can operate at the lowest required water flow temperature when only floor heating is required. Higher water flow temperatures are only required in case fan coil units are operating. This results in better heat pump performance.

**Pump operation and space heating**

The pump (1.8) and (11) will operate when there is a request for heating from A and/or B. The outdoor unit will start operating to achieve the target water flow temperature. The target water leaving temperature depends on which room thermostat is requesting heating.

When the room temperature of both zones is above the thermostat set point, the outdoor unit and pump will stop operating.



**NOTE**

Make sure to correctly configure the room thermostat installation on the user interface. Refer to "10.7 Field settings/ROOM THERMOSTAT".



**NOTE**

- It is the installers' responsibility to ensure that no unwanted situations can occur (e.g. extremely high temperature water going towards floor heating loops, etc.)
- The supplier does not offer any type of mixing station. Dual set point control only provides the possibility to use two set points.
- When only zone A requests heating, zone B will be fed with water at a temperature equal to the first set point. This can lead to unwanted heating in zone B.
- When only zone B requests heating, the mixing station will be fed with water at a temperature equal to the second set point. Depending on the control of the mixing station, the floor heating loop can still receive water at a temperature equal to the set point of the mixing station.
- Be aware that the actual water temperature through the floor heating loops depends on the control and setting of the mixing station.

**8.7 Application 7**

Space cooling and heating application without a room thermostat connected to the unit, but the temperature sensor attached in the user interface is used to control the ON/OFF of the unit. Heating is provided through floor heating loops. Cooling is provided through the fan coil units. A 3-way valve is used to change the direction of water flow when the operation mode changed.

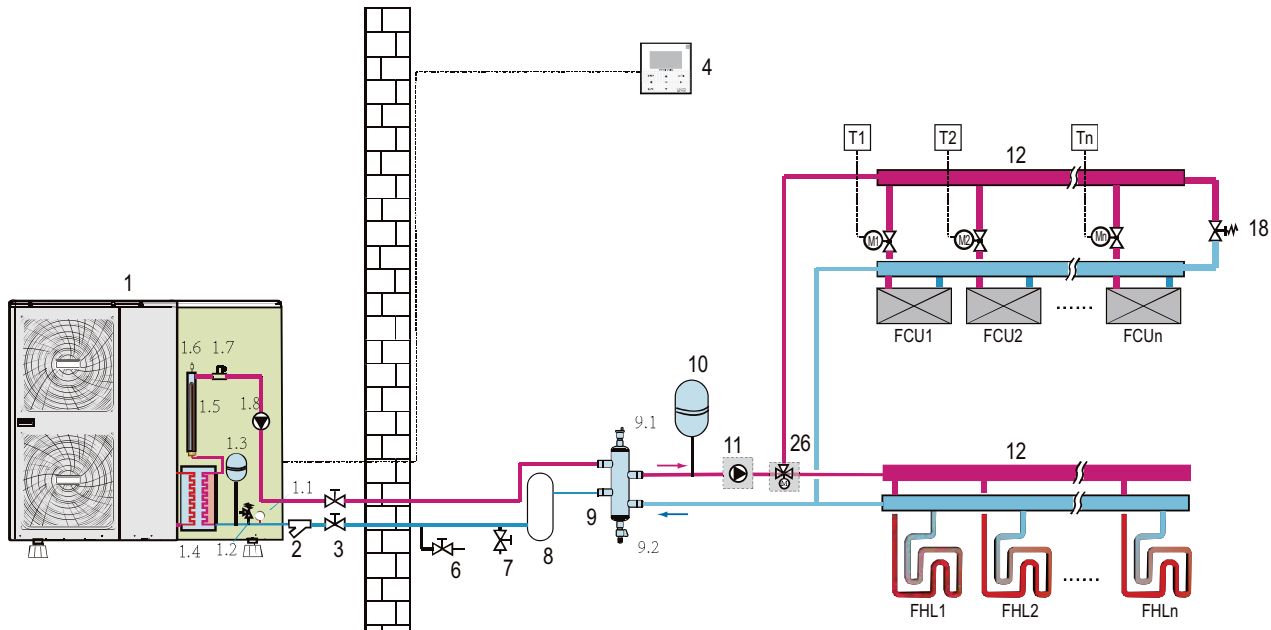

- |                                     |                                   |                                       |
|-------------------------------------|-----------------------------------|---------------------------------------|
| 1 outdoor unit                      | 3 stop valve(field supply)        | pump(field supply)                    |
| 1.1 manometer                       | 4 user interface                  | 12 collector(field supply)            |
| 1.2 pressure relief valve           | 6 drain valve(field supply)       | 18 bypass valve(field supply)         |
| 1.3 expansion vessel                | 7 fill valve(field supply)        | 26 3-way valve(field supply)          |
| 1.4 plate heat exchanger            | 8 buffer tank(field supply)       | FHL 1...n floor heating loop          |
| 1.5 backup heater                   | 9 balance tank(field supply)      | FCU 1...n fan coil units              |
| 1.6 air purge valve                 | 9.1 air purge valve               | M1...n motorized valve (field supply) |
| 1.7 flow switch                     | 9.2 drain valve                   | T1...n room thermostat (field supply) |
| 1.8 P_i: circulate pump in the unit | 10 expansion vessel(field supply) |                                       |
| 2 y-shape filter                    | 11 P_o:outside circulate          |                                       |



**NOTE**

If the volume of balance tank(9) larger than 30L, the buffer tank(8) is unnecessary, otherwise the buffer tank(8) should be installed and the total volume of balance tank and buffer tank should larger than 30L. The drain valve (6) should be installed at the lowest position of the system. For the 5/7kW unit. The backup heater (1.5) is not integrated in the outdoor unit. An independent backup heater can be selected and installed in the door. The wiring of the 3-way valve (26) should follow the wiring of 2-way valve SV2 (refer to **9.6.6 Connection for other components/ For 2-way valve SV2**).

In normal condition, port A should be opened, while signal sent to the 3-way valve (26), port A will be closed and port B will be opened. When in cool mode, ON signal will sent from outdoor unit to the 3-way valve (26), the cold water will flow through port inlet to port B, and port B should connect to the fan coil units. While in heating mode, the hot water will flow through port inlet to port A, and port A should connect to the floor heating loops. In this way, all the water from the unit will flow through the floor heating loops and thus ensure better performance of the floor heating.

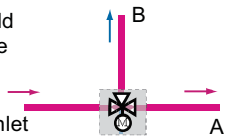

As the temperature sensor is used to detect the room temperature, the user interface (4) should be placed in the room where floor heating loops and fan coil units is installed. Correct configuration should be applied in the user interface (refer to **10.7 field settings/TEMP. TYPE SETTING**). The target room temperature can be set on the main page of user interface, the target outlet water temperature will be calculated from climate related curves, the unit will turn off when the room temperature reaches the target temperature.

8.8 Application 8

Space heating application and domestic hot water heating with a solar energy kit connect to the system, space heating is provided by heat pump, domestic hot water heating is provided by heat pump and solar energy kit.

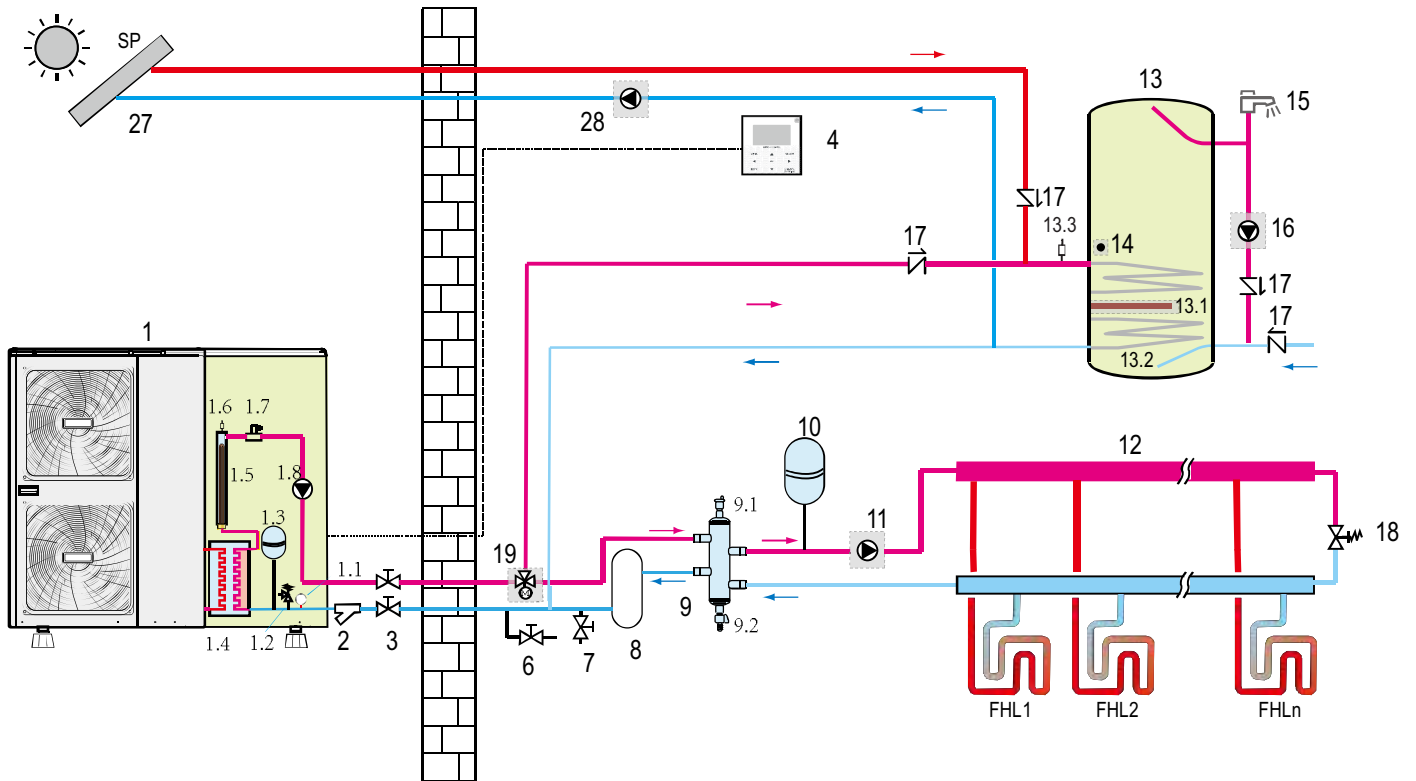

- |                                     |  |                                   |
|-------------------------------------|--|-----------------------------------|
| 1 outdoor unit                      | 4 user interface                             | 13.1 booster heater               |
| 1.1 manometer                       | 6 drain valve(field supply)                  | 13.2 heat exchanger coil          |
| 1.2 pressure relief valve           | 7 fill valve(field supply)                   | 13.3 air purge valve              |
| 1.3 expansion vessel                | 8 buffer tank(field supply)                  | 14 T5:temperature sensor          |
| 1.4 plate heat exchanger            | 9 balance tank(field supply)                 | 15 hot water tap(field supply)    |
| 1.5 backup heater                   | 9.1 air purge valve                          | 16 P_d: DHW pump(field supply)    |
| 1.6 air purge valve                 | 9.2 drain valve                              | 17 non-return valve(field supply) |
| 1.7 flow switch                     | 10 expansion vessel(field supply)            | 18 bypass valve(field supply)     |
| 1.8 P_i: circulate pump in the unit | 11 P_o: outside circulate pump(field supply) | 19 SV1: 3-way valve(field supply) |
| 2 y-shape filter                    | 12 collector(field supply)                   | FHL 1...n floor heating loop      |
| 3 stop valve(field supply)          | 13 domestic hot water tank(optional)         | 27 Solar energy kit(field supply) |
|                                     |  | 28 P_s: Solar pump(field supply)  |

**NOTE**

If the volume of balance tank(9) larger than 30L, the buffer tank(8) is unnecessary, otherwise the buffer tank(8) should be installed and the total volume of balance tank and buffer tank should larger than 30L. The drain valve (6) should be installed at the lowest position of the system. For the 5/7kW unit, the backup heater (1.5) is not integrated in the outdoor unit. An independent backup heater can be selected and installed in the door.

The pump (1.8) and (11) will operate when there is a request for heating floor heating loops. The outdoor unit will start operating to achieve the target water flow temperature. The target water can be set in the user interface. if solar energy is set available in the user interface(refer to **10.7 Field settings/OTHER HEATING SOURCE** ), the heating of domestic hot water can be done by either the solar energy kit or heat pump. when the solar energy kit turns on, signal will sent to the outdoor unit, then the pump (28) will operate, the heat pump will stop heating for domestic hot water during solar energy kit operation .

**NOTE**

Make sure to wiring the solar energy kit(27) and solar pump(28) correctly, refer to **"9.6.6 Connection for other components/For solar energy kit"**. User interface should be correctly configured, refer to **"10.7 Field settings/OTHER HEATING SOURCE"**.

## 9 OVERVIEW OF THE UNIT

### 9.1 Opening the unit

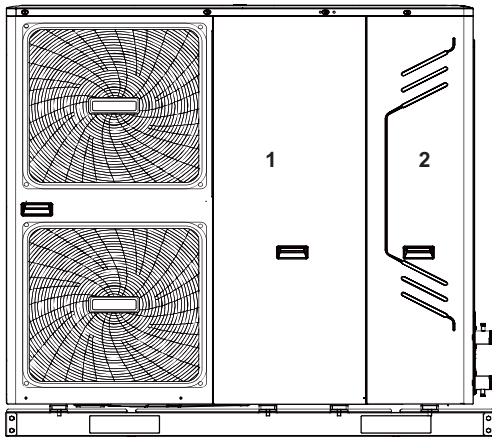

- Door 1 gives access to the compressor compartment and electrical parts.
- Door 2 gives access to the hydraulic compartment and electrical parts.

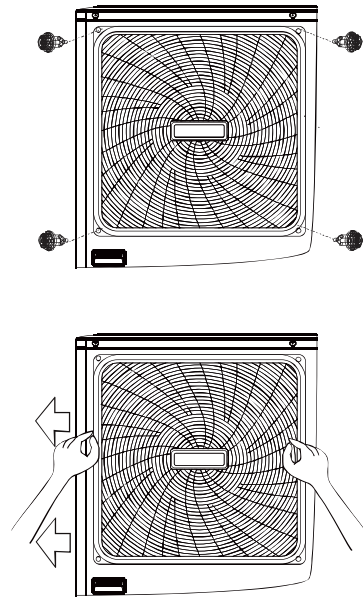
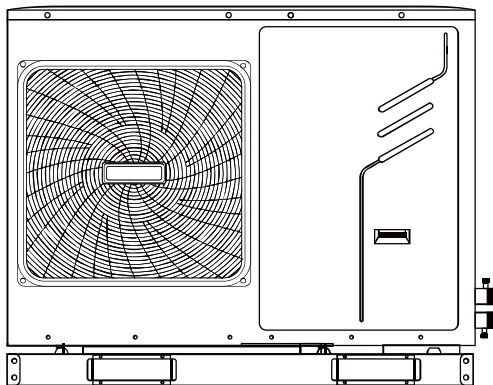

### 9.2 Main components

#### 9.2.1 Hydraulic compartment (door 2)

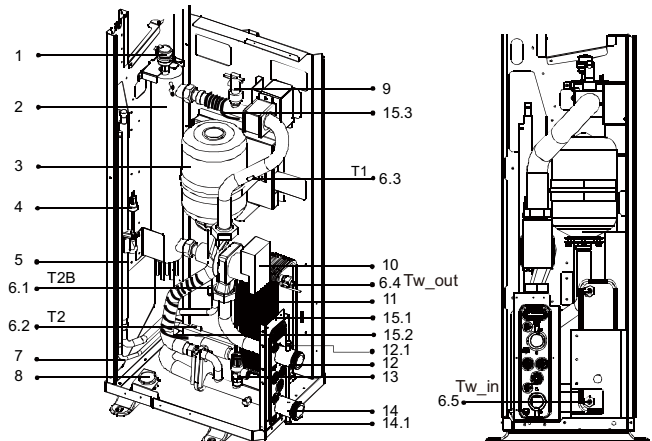

**1-phase 10~16kW**  
**3-phase 12~16kW**



### WARNING

Switch off all power — i.e. unit power supply and backup heater and domestic hot water tank power supply (if applicable) — before removing doors 1 and 2.



### CAUTION

Parts inside the unit may be hot.

Push the grill to the left until it stops, then pull its right edge, the grill can now be removed. You can also reverse the procedure. Exercise caution to avoid a possible hand injury.

1. Air purge valve  
Remaining air in the water circuit will be automatically removed via the air purge valve.

2. Backup heater  
The backup heater consists of an electrical heating element that will provide additional heating capacity to the water circuit if the heating capacity of the unit is insufficient due to low outdoor temperatures. It also protects the external water piping from freezing.

- 3.Expansion vessel (1.32 gallons (5 L))
- 4.Pressure Sensor
- 5.Refrigerant gas connection
- 6.Temperature sensors

Four temperature sensors determine the water and refrigerant temperature at various points in the water circuit.

- 6.1-T2B; 6.2-T2; 6.3-T1; 6.4-TW\_out; 6.5-TW\_in
- 7.Refrigerant liquid connection

8.Manometer

The manometer provides a water pressure readout of the water circuit

9.Flow switch

The flow switch checks the flow in the water circuit and protects the heat exchanger against freezing and the pump against damage.

10.Pump

The pump circulates the water in the water circuit.

11.Heat exchanger

The manometer provides a water pressure readout of the water circuit.

12.Water outlet connection

12.1 Air purge valve

13.Pressure relief valve

The pressure relief valve prevents excessive water pressure in the water circuit by opening at 43.5 psi (3 bar) and discharges water.

14.Water inlet connection

14.1 Drain valve

15.Electrical heating tape(15.1-15.3)

13.Pressure relief valve

The pressure relief valve prevents excessive water pressure in the water circuit by opening at 43.5 psi (3 bar) and discharging water.

14.Water inlet connection

14.1 Drain valve

15.1.Electrical heating tape

18. sleeve for insert temperature sensor

9.2.2 Functional diagram of hydraulic compartment (door 2)

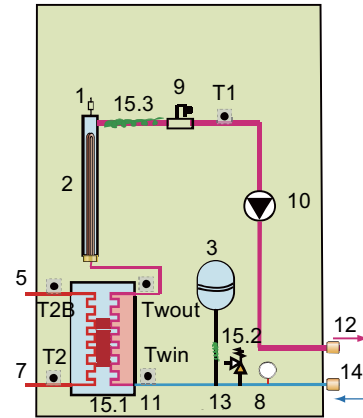

1-phase 10~16kW  
3-phase 12~16kW

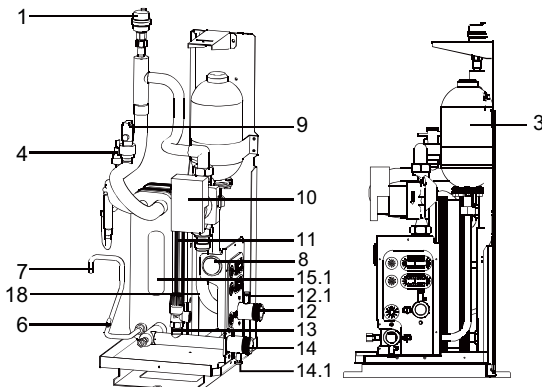

1-phase 5/7kW

1.Air purge valve

Remaining air in the water circuit will be automatically removed via the air purge valve.

3.Expansion vessel (0.88gallons (2 L))

4.Pressure Sensor

6.Temperature sensors

Four temperature sensors determine the water and refrigerant temperatures at various points in the water circuit.

7.Refrigerant liquid connection

8.Manometer

The manometer provides a water pressure readout of the water circuit.

9.Flow switch

The flow switch checks the flow in the water circuit and protects the heat exchanger against freezing and the pump against damage.

10.Pump

The pump circulates the water in the water circuit.

11.Heat exchanger

12.Water outlet connection

12.1 Air purge valve

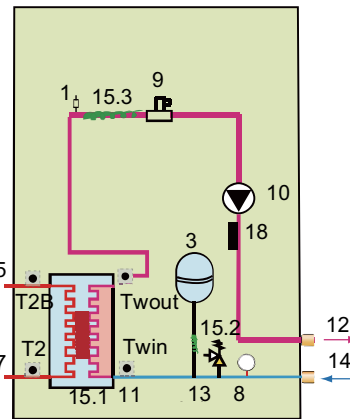

1-phase 5/7kW

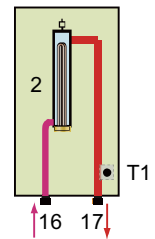

backup heater box  
1-phase 5/7kW  
(Optional CL97066)

- 1 Air purge valve
- 2 Backup heater vessel with backup heater
- 3 Expansion vessel
- 5 Refrigerant gas connection
- 7 Refrigerant liquid connection
- 8 Manometer
- 9 Flow switch
- 10 Circulation Pump
- 11 Heat exchanger
- 12 Water outlet connection
- 13 Pressure relief valve
- 14 Water inlet connection
- 15.1 Electrical heating tape
- 15.2 Electrical heating tape
- 15.3 Electrical heating tape
- 16 Water inlet connection (5/7kW only)
- 17 Water outlet connection(5/7kW only)
- Temperature sensors:TW\_in;TW\_out;T2B;T2;T1
- 18 Sleeve for insert temperature sensor

NOTE if backup heater box is not installed for 5/7 kW unit, the temperature sensor(T1) should be installed and be inserted into sleeve (18) , if backup heater box is installed, it should be insert to the sleeve that located at the outlet of the box, insulation is needed for the temperature sensor.



The image shown here is indicative only. If there is inconsistency between the image and the actual product, the actual product shall govern.

9.2.3 Switch box main components (door2)

**All models HIDROBOX PCB**

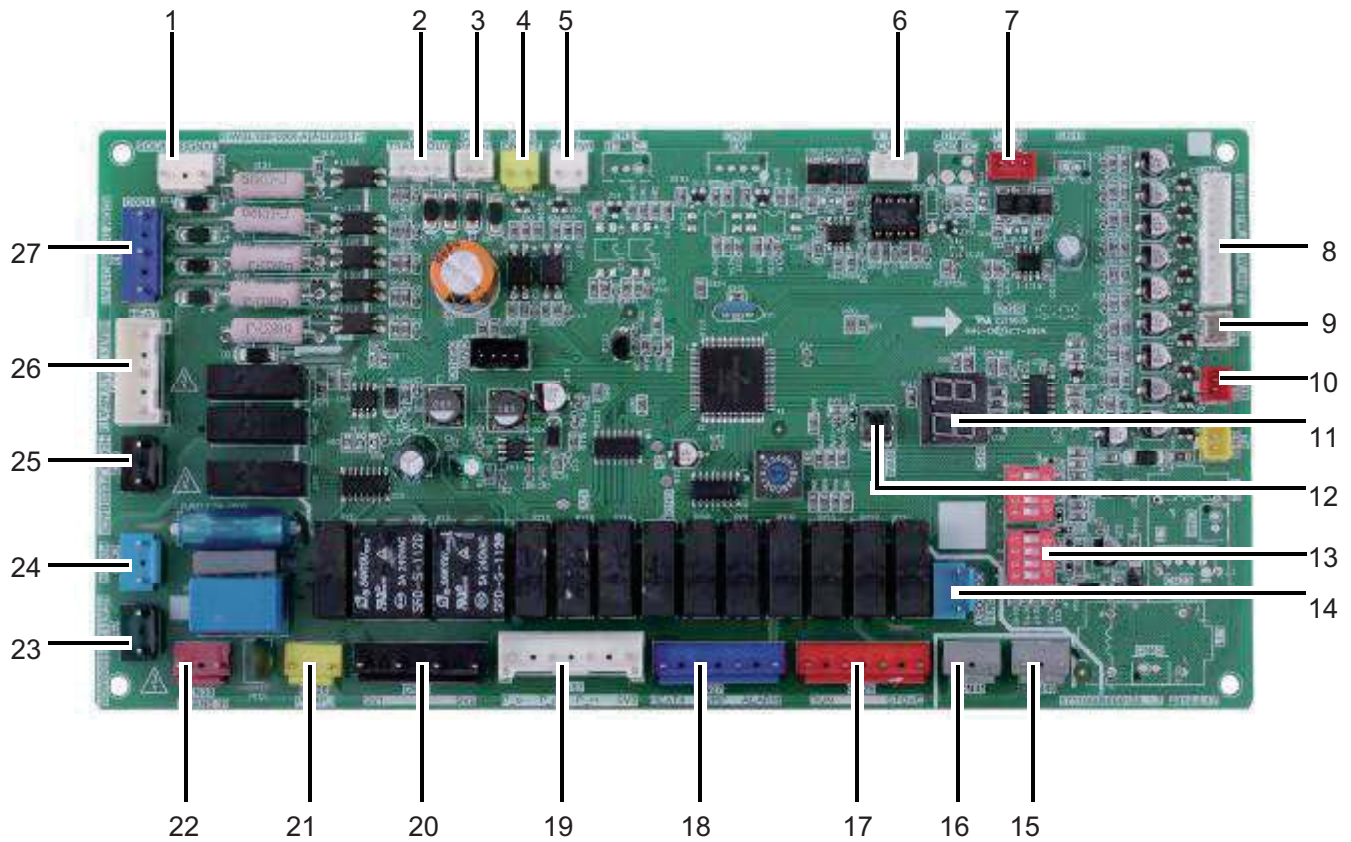

- |  |   |
|--|---|
| <ul style="list-style-type: none"> <li>1 Input port for solar energy(CN5)</li> <li>2 Output port for transformer(CN4)</li> <li>3 Power supply port for user interface(CN36)</li> <li>4 Port for remote switch(CN12)</li> <li>5 Port for flow switch (CN8)</li> <li>6 Communicate port between door PCB B and door PCB(CN14)</li> <li>7 Communicate port between door PCB and user interface(CN19)</li> <li>8 Port for temperature sensors(Twout, Twin, T1, T2,T2B )(CN6)</li> <li>9 Port for temperature sensor(CN13)</li> <li>10 Port for temperature sensor(T1B, the final outlet temp.)(CN15)</li> <li>11 Digital displays(DIS1)</li> <li>12 Check button(SW4)</li> <li>13 DIP switch(S1,S2)</li> <li>14 output port for deforst(CN34)</li> <li>15 Port for anti-freeze electric heating tape (internal)(CN40)</li> </ul> | <ul style="list-style-type: none"> <li>16 Port for anti-freeze electric heating tape (internal)(CN41)</li> <li>17 Output port for external heating source / operation output port(CN25)</li> <li>18 Port for anti-freeze electric heating tape(external) /port for solar energy pump/output port for remote alarm(CN27)</li> <li>19 Port for external circulted pump/pipe pump/mix pump/2-way valve SV2(CN37)</li> <li>20 Port for SV1(3-way valve) and SV3(CN24)</li> <li>21 Port for internal pump(CN28)</li> <li>22 Input port for transformer(CN20)</li> <li>23 Feedback port for temperature switch(CN1)</li> <li>24 Port for power supply(CN21)</li> <li>25 Feedback port for external temp. switch(shorted in default)(CN2)</li> <li>26 Control port backup heater/booster heater(CN22)</li> <li>27 Control port for room thermostat(CN3)</li> </ul> |
|--|---|

**5/7kW (230V) - IPM Board**

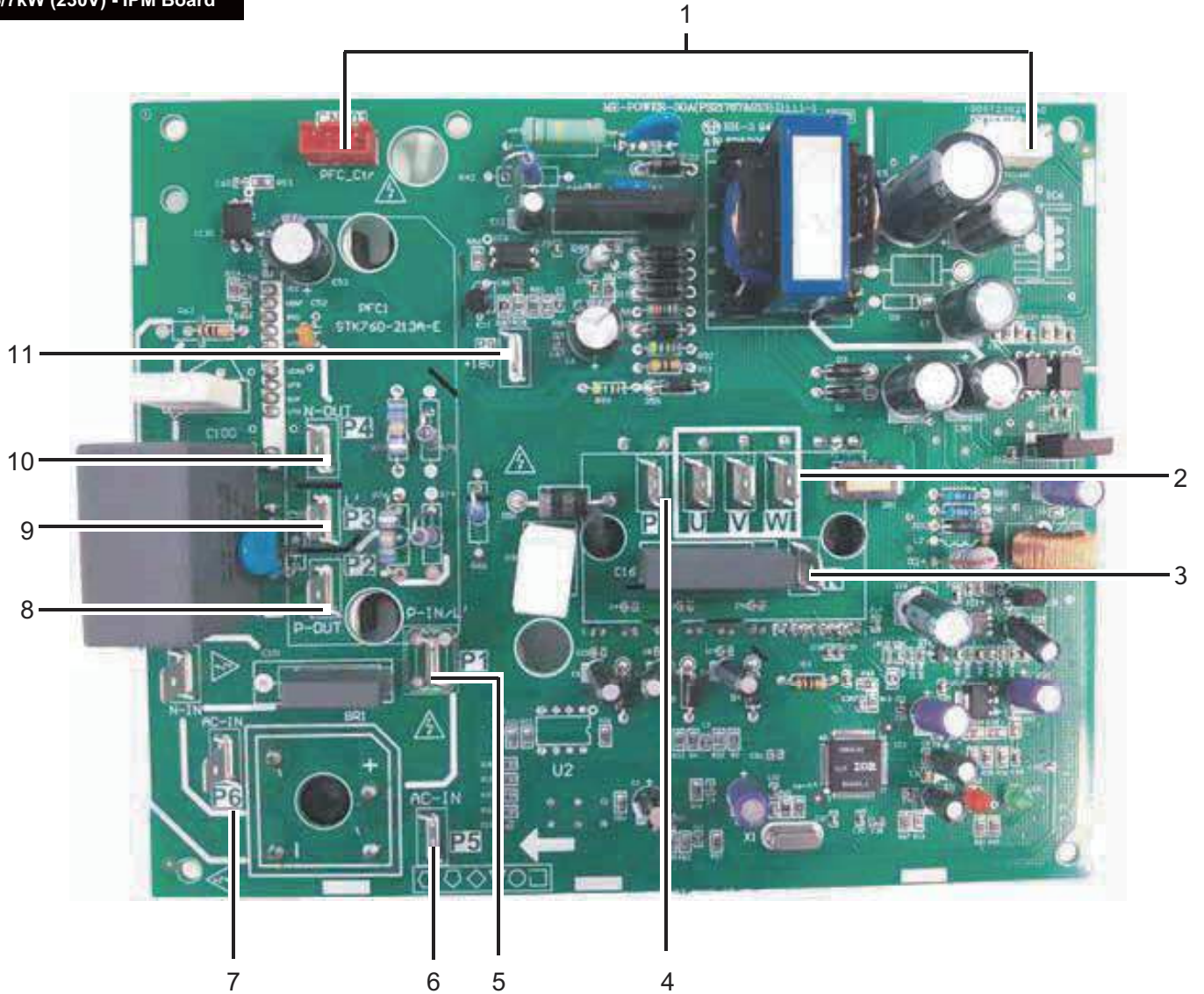

- 1 To main board (CN101,CN105)
- 2 Compressor connection port U V W (U,V,W)
- 3 Input port N for IPM module(N)
- 4 Input port P for IPM module(P)
- 5 Input port for PFC inductance P1(P1)
- 6 Input port for bridge Rectifiers(P5)
- 7 Input port for Bridge Rectifiers(P6)
- 8 Output port P of PFC(P2)
- 9 Input port for PFC inductance 3(P3)
- 10 Output port N of PFC(P4)
- 11 +18V(P9)



**5/7kW (230V) - Main Board**

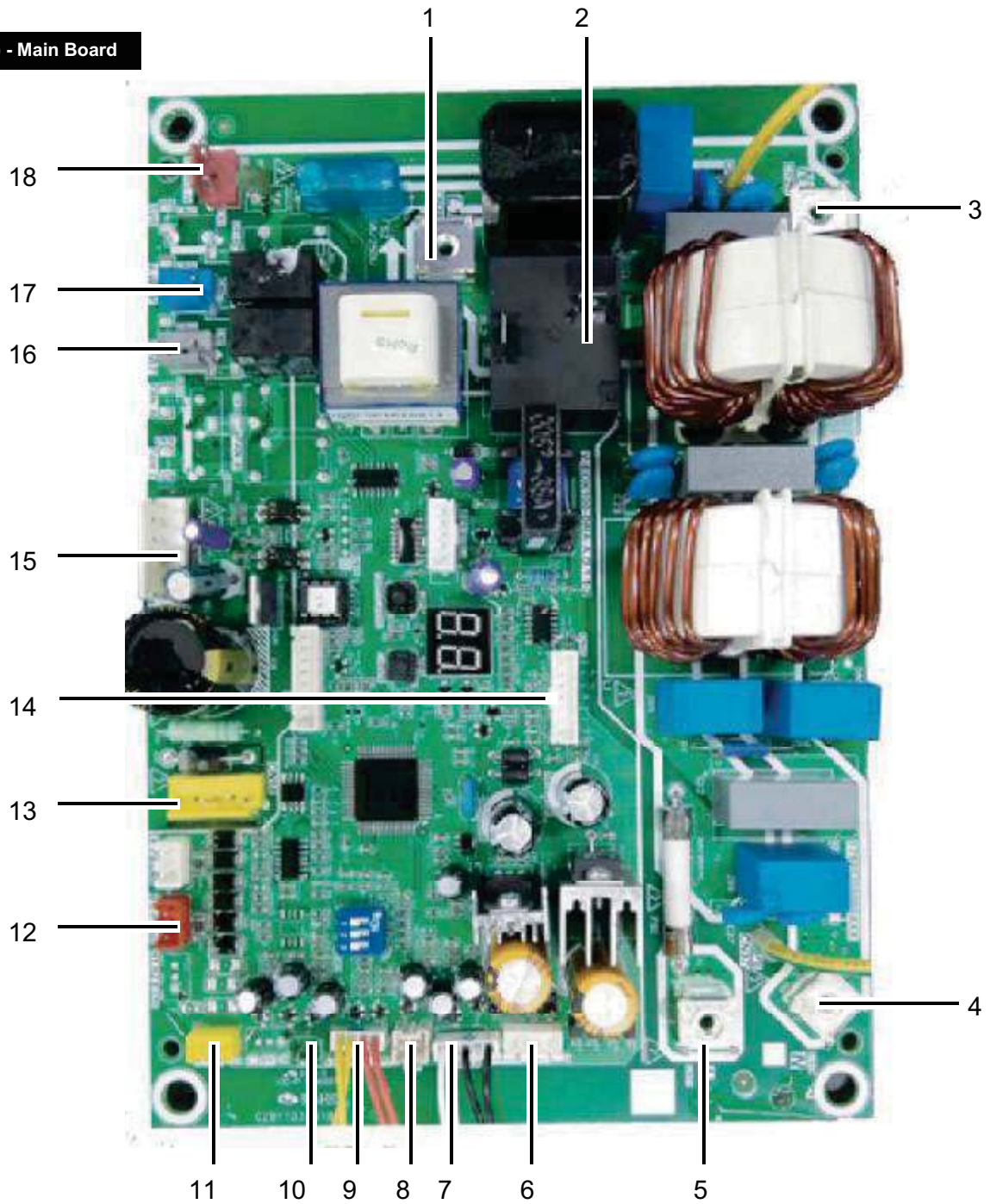

- |   |  |
|---|--|
| 1 Rectifier bridge input port L   | 10 Th temperature sensor port                    |
| 2 Hydraulic compartment input port2                                     | 11 Pressure sensor port                          |
| 3 Rectifier bridge input port N   | 12 Wire controller port                          |
| 4 Power supply N  | 13 P/N/+18V port                                 |
| 5 Power supply L  | 14 To IPDU/PFC                                   |
| 6 Transformer output port   | 15 DC fan port                                   |
| 7 BLACK: T3 temperature sensor port<br>WHITE:T4 temperature sensor port | 16 Compression electromechanical<br>heating belt |
| 8 TP temperature sensor port  | 17 4-way valve port                              |
| 9 YELLOW: High pressure switch<br>RED: Low pressure switch              | 18 Transformer input port                        |

**10 to 16kW (230V) - IPM Board**

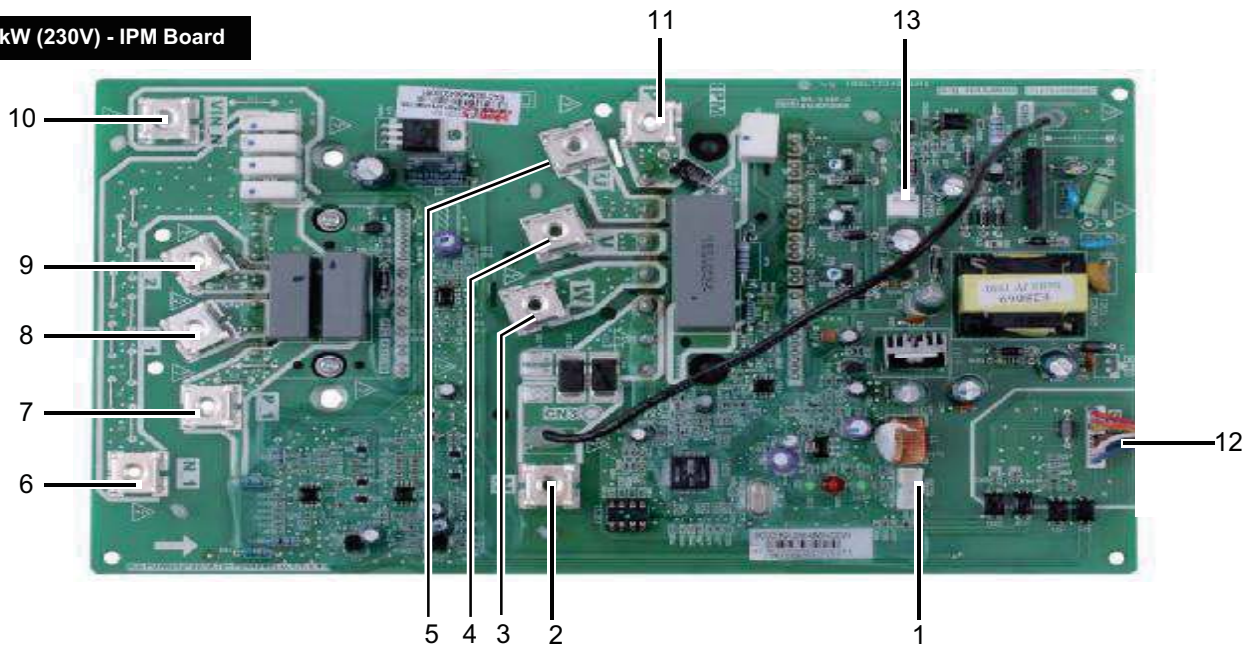

- |   |   |  |
|---|---|--|
| 1 Reserved(CN2)                             | 5 Power Supply Of U Phase For Compressor(U) | 10 Input Port N For Pfc Module(VIN-N)            |
| 2 Input Port N For Ipm Module(N)            | 6 Output Port N Of Pfc Module(N_1)          | 11 Input Port P Foripm Modele(P)                 |
| 3 Power Supply Of W Phase For Compressor(W) | 7 Output Port P Of Pfc Module(P_1)          | 12 Communicate Port Between Pcb A And Pcb B(CN1) |
| 4 Power Supply Of V Phase For Compressor(V) | 8 Input Port For Pfc Inductance L_1(L_1)    | 13 +15V(CN6)                                     |
|   | 9 Input Port For Pfc Inductance L_2(L_2)    |  |

**10 to 16kW (230V) - Main Board**

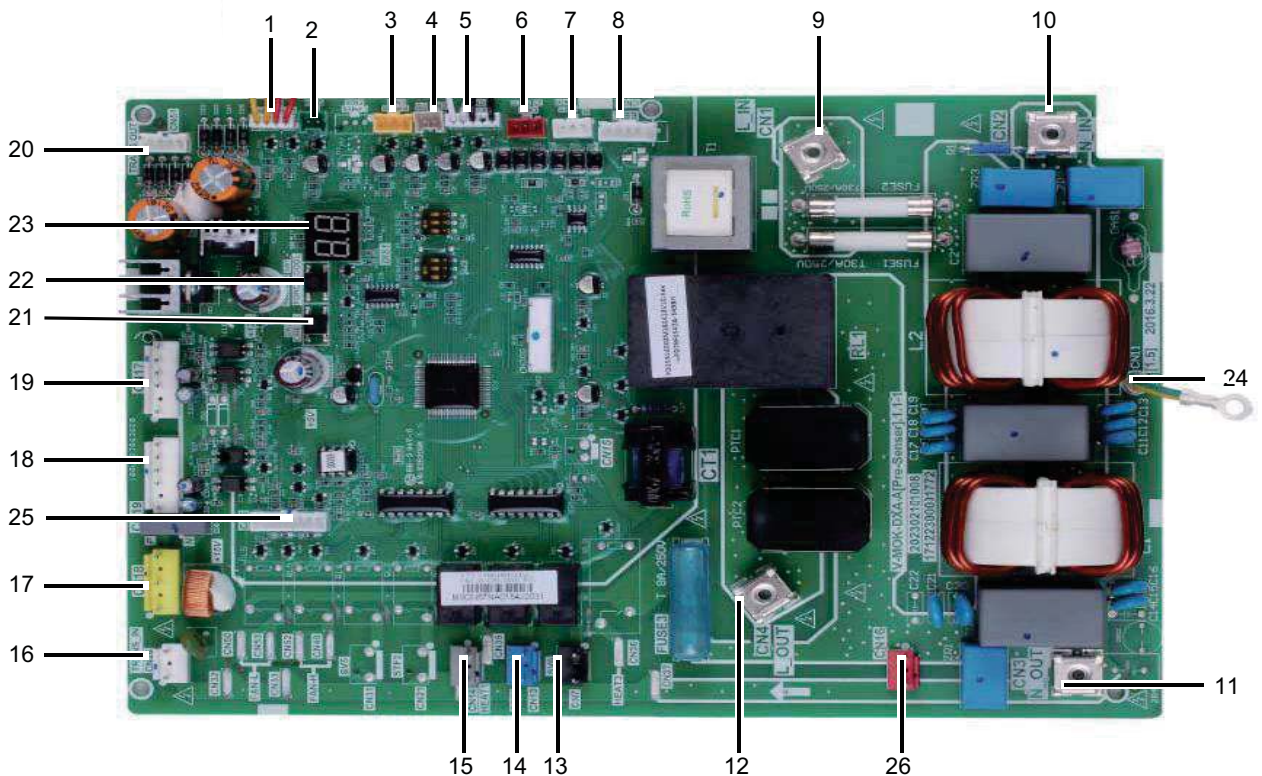

- |   |   |  |
|---|---|--|
| 1 Port For Pressure Switch(CN12)  | 7 Reserved(CN30)                            | 17 Power Supply Port For Fan(CN18)                     |
| 2 Port For Suction Temperature Sensor(CN24)                                 | 8 Port For Electrical Expansion Valve(CN22) | 18 Port For Down Fan(CN19)                             |
| 3 Port For Pressure Sensor(CN28)  | 9 Input Port For Live Wire(CN1)             | 19 Port For Up Fan(CN17)                               |
| 4 Port For Discharge Temperature Sensor(CN8)                                | 10 Input Port For Neutral Wire(CN2)         | 20 Output Port For Transformer(CN51)                   |
| 5 Port For Ambient Temperature And Condenser Outlet Temperature Sensor(CN9) | 11 Output Port For Neutral Wire(CN3)        | 21 Check Button(SW2)                                   |
| 6 Port For Communication Between Outdoor Unit And Bydro-box(CN10)           | 12 Ourput Port For Live Wire(CN4)           | 22 Refrigerant Recovery Button                         |
|   | 13 Reserved(CN7)                            | 23 Digital Displays(DIS1)                              |
|   | 14 Port For 4-way Valve(CN13)               | 24 Ground Wire(CN11)                                   |
|   | 15 Port For Eletric Heating Tape(CN14)      | 25 Comunication Port For PCBA(CN6)                     |
|   | 16 Input Port For Transformer(CN26)         | 26 Power supply port for hydro-box control board(CN16) |



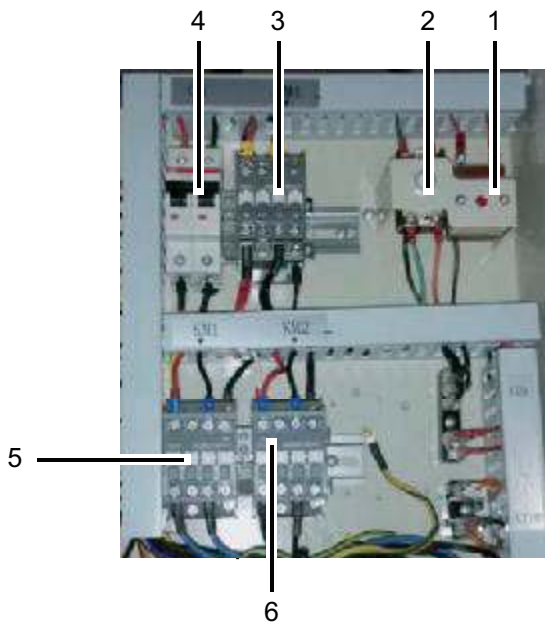

- 1 Auto thermal protector
- 2 Manu thermal protector
- 3 Backup heater contactor KM4
- 4 Backup heater circuit breaker CB
- 5 Backup heater contactor KM1
- 6 Backup heater contactor KM2

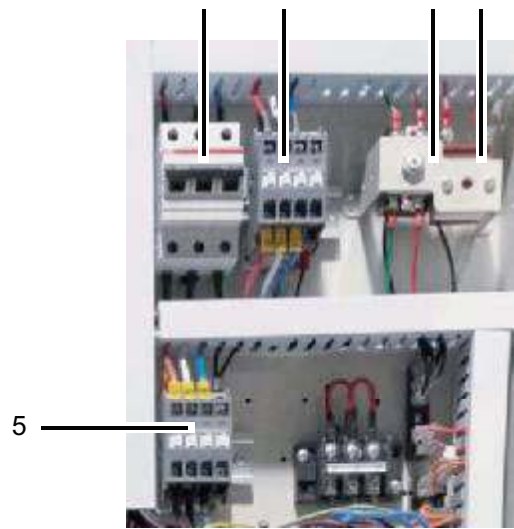

3-phase 12~16kw

- 1 Auto thermal protector
- 2 Manu thermal protector
- 3 Backup heater contactor KM4
- 4 Backup heater circuit breaker CB
- 5 Backup heater contactor KM1

**12 to 16kW (400V) - Filter Board**

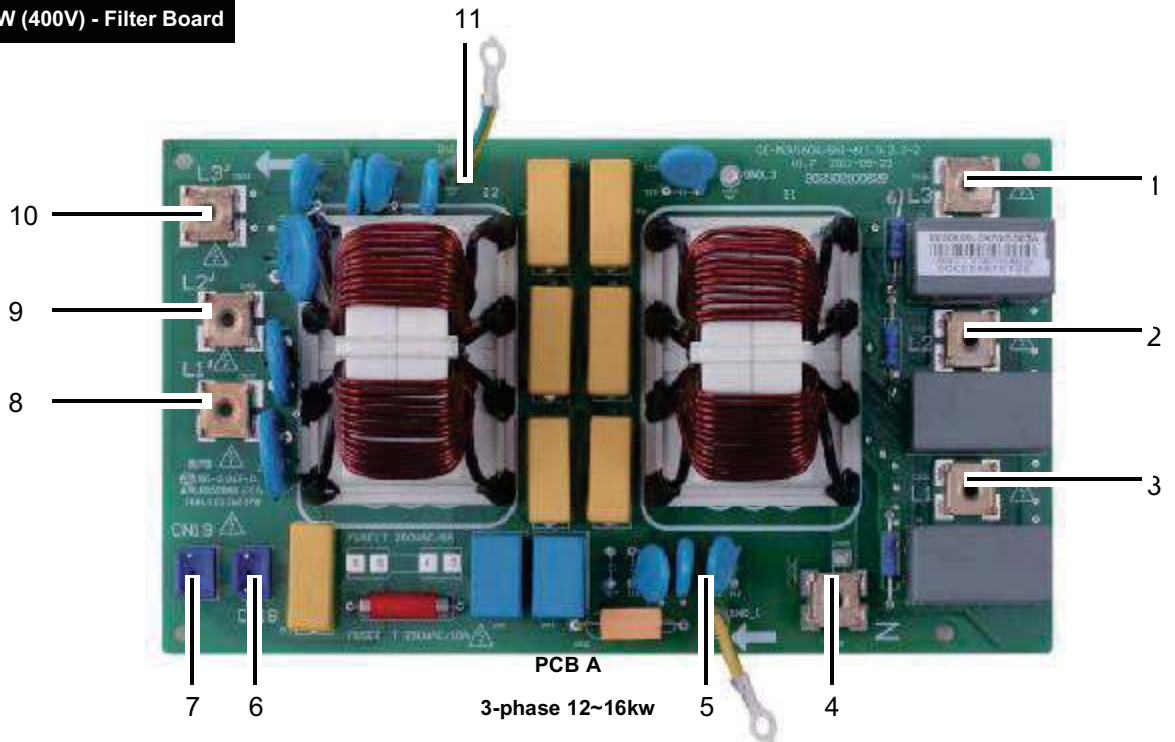

3-phase 12~16kw

- 1 Power supply L3(L3)
- 2 Power supply L2(L2)
- 3 Power supply L1(L1)
- 4 Power supply N(N)
- 5 Ground wire(GND\_1)
- 6 Power supply for load(CN18)
- 7 Power supply for main control board(CN19)
- 8 Power filtering L1(L1')
- 9 Power filtering L2(L2')
- 10 Power filtering L3(L3')
- 11 Ground wire(GND\_2)

**12 to 16kW (400V) - Main Board**

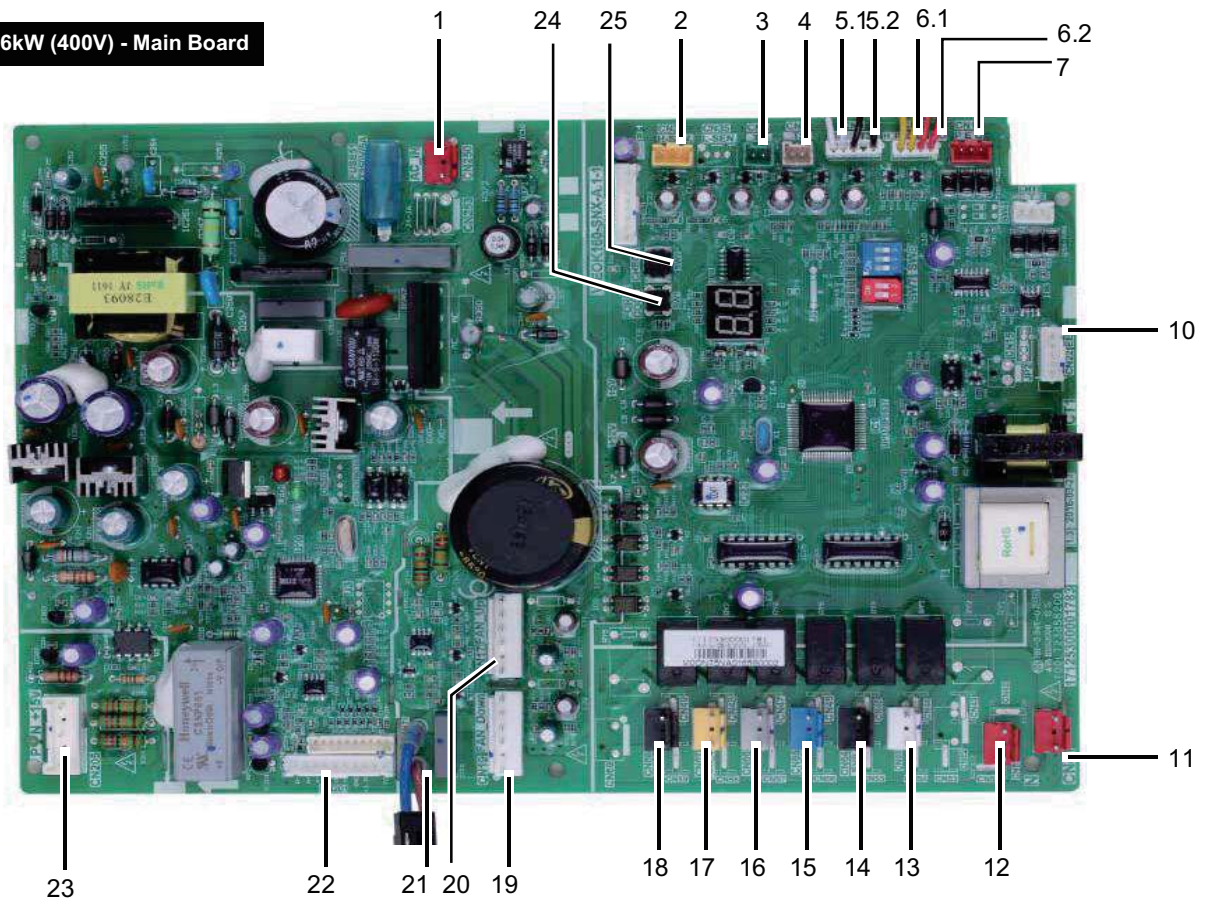

- |   |  |  |
|---|--|--|
| 1 Power supply for the main PCB(CN250)                | 10 Port for electrical expansion valve(CN22)     | 18 Reserved(CN68)                        |
| 2 Port for pressure sensor(CN36)                      | 11 Port for power supply(CN41)                   | 19 Port for down fan(CN19)               |
| 3 Port for suction temperature sensor(CN4)            | 12 Power supply for hydro-box control board(CN6) | 20 Port for up fan(CN17)                 |
| 4 Port for discharge temperature sensor(CN8)          | 13 PFC control port(CN63)                        | 21 Power supply port for module(CN70/71) |
| 5.1 Port for outdoor temperature sensor(CN9)          | 14 Reserved(CN64)                                | 22 Communication port for IPDU(CN201)    |
| 5.2 Port for condenser outlet temperature sensor(CN9) | 15 Port for 4-way valve(CN65)                    | 23 Port for voltage check(CN205)         |
| 6.1 Port for high pressure switch(CN6)                | 16 Port for electric heating tape(CN66)          | 24 Refrigerant recovery button(SW1)      |
| 6.2 Port for low pressure switch(CN6)                 | 17 PTC control(CN67)                             | 25 Check button(SW2)                     |

**12 to 16kW (400V) - IPM Board**

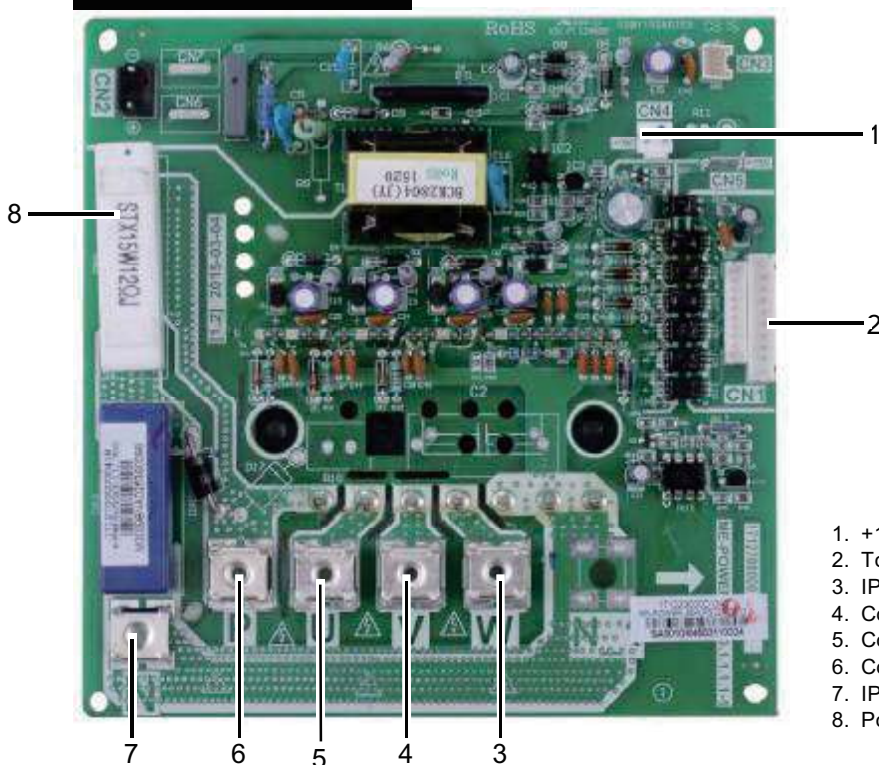

- |  |
|--|
| 1. +15V port(CN4)                        |
| 2. To MCU(CN1)                           |
| 3. IPM input N                           |
| 4. Compressor connection port W          |
| 5. Compressor connection port V          |
| 6. Compressor connection port U          |
| 7. IPM input P                           |
| 8. Power for switching power supply(CN2) |



**9.3 Water pipework**

All piping lengths and distances have been taken into consideration.

Requirements	Valve
The maximum allowed thermistor cable length is 20m. This is the maximum allowable distance between the domestic hot water tank and the unit (only for installations with a domestic hot water tank). The thermistor cable supplied with the domestic hot water tank is 10m in length. In order to optimize efficiency we recommend installing the 3-way valve and the domestic hot water tank as close as possible to the unit	Thermistor cable length minus 2m

- NOTE**
- If the installation is equipped with a domestic hot water tank (optional), please refer to the domestic hot water tank Installation & Owner's Manual.
  - If there is no glycol (anti-freeze) in the system there is a power supply or pump failure, drain the system (as shown in the figure below).

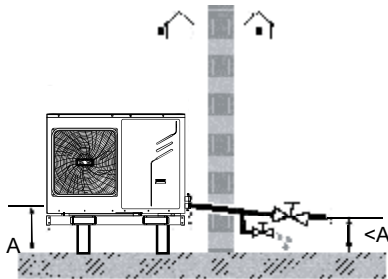

When water is not moving inside the system in cold weather, freezing is very likely and will damage the system.

**Checking the water circuit**

The units are equipped with a water inlet and outlet for connection to a water circuit. This circuit must be provided by a licensed technician and must comply with local laws and regulations.

The unit is only to be used in a closed water system. Application in an open water circuit can lead to excessive corrosion of the water piping.

**Example**

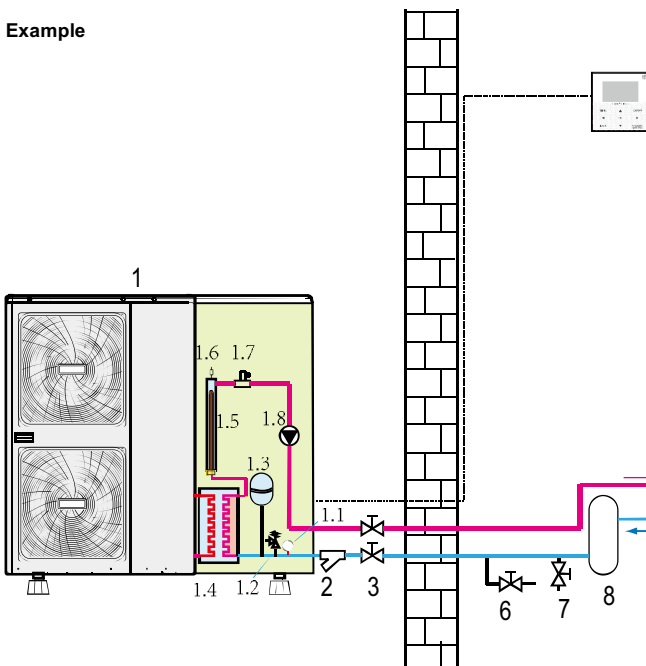

Before continuing installation of the unit, check the following:

- The maximum water pressure = 3 bar.
- The maximum water temperature is 70°C according to safety device setting.
- Always use materials that are compatible with the water used in the system and with the materials used in the unit.
- Ensure that components installed in the field piping can withstand the water pressure and temperature.
- Drain taps must be provided at all low points of the system to permit complete drainage of the circuit during maintenance.
- Air vents must be provided at all high points of the system. The vents should be located at points that are easily accessible for servicing. An automatic air purge is provided inside the unit. Check that this air purge valve is not tightened too much so that automatic release of air in the water circuit remains possible.

**Checking the water volume and expansion vessel pre-pressure**

The unit is equipped with a 5 L expansion vessel that has a default pre-pressure of 1.5 bar.

To assure proper operation of the unit, the pre-pressure of the expansion vessel might need to be adjusted and the minimum and maximum water volume must be checked.

1. Check that the total water volume in the installation, excluding the internal water volume of the unit, is at least 20L. Refer to 14 Technical specifications to find the total internal water volume of the unit.

- NOTE**
- In most applications this minimum water volume will be satisfactory.
  - In critical processes or in rooms with a high heat load though, extra water might be required.
  - When circulation in each space heating loop is controlled by remotely controlled valves, it is important that this minimum water volume is kept even if all the valves are closed.

- |                                       |   |
|---------------------------------------|---|
| 1 Outdoor Unit                        | 9 Balance Tank(Field Supply)                    |
| 1.1 Manometer                         | 9.1 Air Purge Valve                             |
| 1.2 Pressure Relief Valve             | 9.2 Drain Valve                                 |
| 1.3 Expansion Vessel                  | 10 Expansion Vessel (Field Supply)              |
| 1.4 Plate Heat Exchanger              | 11 P_o: Outside Circulation Pump (Field Supply) |
| 1.5 Backup Heater                     | 12 Collector(Field Supply)                      |
| 1.6 Air Purge Valve                   | 18 Bypass Valve(Field Supply)                   |
| 1.7 Flow Switch                       | FH1...N Floor Heating Loop                      |
| 1.8 P_i: Circulation Pump Inside Unit | M1...N Motorized Valve (Field Supply)           |
| 2 Y-shape Filter                      | T1...n Room Thermostat (Field Supply)           |
| 3 Stop Valve (Field Supply)           |   |
| 4 User Interface                      |   |
| 6 Drain Valve(Field Supply)           |   |
| 7 Fill Valve(Field Supply)            |   |
| 8 Buffer Tank(Field Supply)           |   |



- Using the table below, determine if the expansion vessel pre- pressure requires adjustment.
- Using the table and instructions below, determine if the total water volume in the installation is below the maximum allowed water volume.

Installation height difference <sup>(a)</sup>	Water volume ≤160 l	>160 l
≤7 m	No pre-pressure adjustment required.	Actions required: <ul style="list-style-type: none"> <li>pre-pressure must be decreased, calculate according to "Calculating the pre-pressure of the expansion vessel"</li> <li>check if the water volume is lower than maximum allowed water volume (use graph below)</li> </ul>
>7 m	Actions required: <ul style="list-style-type: none"> <li>Pre-pressure must be increased, calculate according to "Calculating the pre-pressure of the expansion vessel" below.</li> <li>Check if the water volume is lower than maximum allowed water volume (use graph below)</li> </ul>	Expansion vessel of the unit too small for the installation.

(a) Installation height difference: height difference (m) between the highest point of the water circuit and the unit. If the unit is located at the highest point of the installation, the installation height is considered to be 0 m..

**Calculating pre-pressure of the expansion vessel**

The pre-pressure (Pg) to be set depends on the maximum installation height difference (H) and is calculated as follows:  
 $Pg(\text{bar}) = (H(\text{m}) / 10 + 0.3) \text{ bar}$

**Checking the maximum allowed water volume**

To determine the maximum allowed water volume in the entire circuit, proceed as follows:

- Determine the calculated pre-pressure (Pg) for the corresponding maximum water volume using the graph below.
- Check that the total water volume in the entire water circuit is lower than this value.  
 If this is not the case, the expansion vessel inside the unit is too small for the installation.

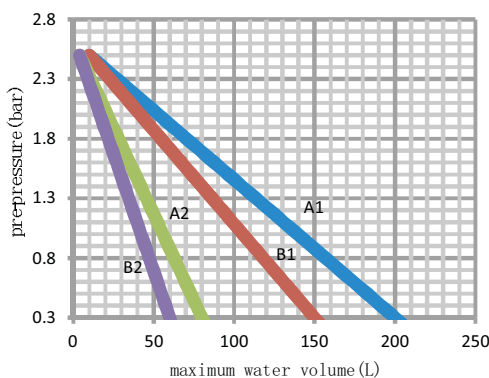

pre-pressure = pre-pressure  
 maximum water volume = maximum water volume

- A1 System without glycol for 1-phase 10~16 kw and 3-phase 12~16 kw unit
- A2 System without glycol for the 5/7 kw unit
- B1 System with 25% propylene glycol for 1-phase 10~16 kw and 3-phase 12~16 kw unit
- B2 System with 25% propylene glycol for the 5/7kw unit (Refer to "Caution: Use of glycol" on page 30.)

**Example 1**

The unit is installed 5 m below the highest point in the water circuit. The total water volume in the water circuit is 100 L. In this example, no action or adjustment is required.

**Example 2**

The unit is installed at the highest point in the water circuit. The total water volume in the water circuit is 180 L. Result:

- Since 180 L is more than 160 L, the pre-pressure must be decreased (see table above).
- The required pre-pressure is:  
 $Pg(\text{bar}) = (H(\text{m}) / 10 + 0.3) \text{ bar} = (0 / 10 + 0.3) \text{ bar} = 0.3 \text{ bar}$
- The corresponding maximum water volume can be read from the graph: approximately 210 L.
- Since the total water volume (180 L) is below the maximum water volume (210 L), the expansion vessel suffices for the installation.

**Setting the pre-pressure of the expansion vessel**

When it is required to change the default pre-pressure of the expansion vessel (1 bar), keep in mind the following guidelines:

- Use only dry nitrogen to set the expansion vessel pre-pressure.
- Inappropriate setting of the expansion vessel pre-pressure will lead to malfunctioning of the system. Pre-pressure should only be adjusted by a licensed installer..

**Connecting the water circuit**

Water connections must be made in accordance with the outlook diagram delivered with the unit, with respect to the water intake and water outlet.



Be careful not to deform the unit's piping by using excessive force when connecting the piping. Deforming the piping can cause the unit to malfunction.

If air, moisture or dust gets in the water circuit, problems may occur. Therefore, always take into account the following when connecting the water circuit:

- Use clean pipes only.
- Hold the pipe end downwards when removing burrs
- Cover the pipe end when inserting it through a wall so that no dust and dirt enter.
- Use a good thread sealant for sealing the connections. The sealing must be able to withstand the pressures and temperatures of the system.
- When using non-brass metallic piping, make sure to insulate both materials from each other to prevent galvanic corrosion.
- Because brass is a soft material, use appropriate tools for connecting the water circuit. Inappropriate tools will cause damage to the pipes.

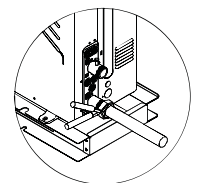

**NOTE**

The unit is only to be used in a closed water system. Application in an open water circuit can lead to excessive corrosion of the water piping:

- Never use Zn-coated parts in the water circuit. Excessive corrosion of these parts may occur as copper piping is used in the unit's internal water circuit.
- When using a 3-way valve in the water circuit. Preferably choose a ball type 3-way valve to guarantee full separation between the domestic hot water and floor heating water circuit.
- When using a 3-way valve or a 2-way valve in the water circuit. The recommended maximum changeover time of the valve should be less than 60 seconds.

**Protecting the water circuit against freezing**

Frost can cause damage to the hydraulic system. As this unit is installed outdoors and thus the hydraulic system is exposed to freezing temperatures, care must be taken to prevent freezing of the system.

All hydraulic parts are insulated to reduce heat loss. Insulation must be present on the field piping.

The unit is already equipped with several features to prevent freezing.

- The software contains special functions using the heat pump to protect the entire system against freezing. When the temperature of the water flow in the system drops to a certain value, the software will heat the water, either using the heat pump, the electric heating tap, or the backup heater. The freeze protection function will turn off only when the temperature increases to a certain value.

In case of a power failure, the features mentioned above cannot protect the unit from freezing. Since a power failure could happen when the unit is unattended, the supplier recommends adding glycol to the water system. Refer to "Caution: Use of glycol" on page 27. Depending on the expected lowest outdoor temperature, make sure the water system is filled with a concentration of glycol as mentioned in the table below.

When glycol is added to the system, the performance of the unit will be affected. The correction factor of the unit capacity, flow rate and pressure drop of the system is listed in the table below:

	Freezing point( )					
	0	-5	-10	-15	-20	-25
	Percentage of ethylene glycol in weight					
	0	12%	20%	28%	35%	40%
cPf	1	0.98	0.97	0.965	0.96	0.955
cQ	1	1.02	1.04	1.075	1.11	1.14
cdp	1	1.07	1.11	1.18	1.22	1.24

cPf: correction factor for unit heating capacity  
 cQ: correction factor for flow rate  
 CDP: correction factor for system pressure drop

If no glycol is added, the water must be drained out when there is a power failure.

Water may enter into the flow switch and cannot be drained out and may freeze when the temperature is low enough. The flow switch should be removed and dried, then can be reinstalled in the unit.

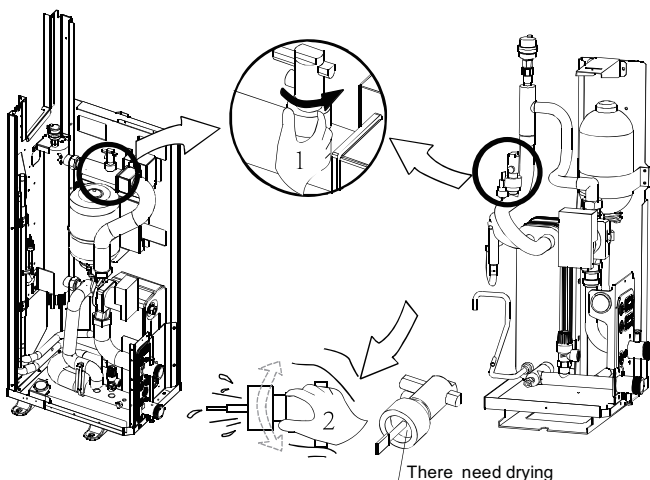

**NOTE**

- Counterclockwise rotation, remove the flow switch.
- Drying the flow switch completely.



**WARNING**

**(a) ETHYLENE GLYCOL IS TOXIC**

The concentrations mentioned in the table above will not prevent freezing, but will prevent the hydraulics from bursting.



**CAUTION**

**Use of glycol**

- Glycol use for installations with a domestic hot water tank:
  - Only propylene glycol having a toxicity rating or class of 1, as listed in "Clinical Toxicology of Commercial Products, 5th edition" may be used.
  - The maximum allowed water volume is then reduced according to the figure "Maximum allowed water volume" on page 25.
- If there is too much pressure when using glycol, connect the safety valve to a drain pan to recover the glycol.

**Corrosion in the system due to glycol**

Uninhibited glycol will turn acidic under the influence of oxygen. This process is accelerated by presence of copper and at higher temperatures. The acidic uninhibited glycol attacks metal surfaces and forms galvanic corrosion cells that cause severe damage to the system.

It is of extreme importance:

- That the water treatment is correctly executed by a qualified water specialist.
- That a glycol with corrosion inhibitors is selected to counteract acids formed by the oxidation of glycols.
- That in case of an installation with a domestic hot water tank, only the use of propylene glycol is allowed. In other installations the use of ethylene glycol is fine.
- That no automotive glycol is used because their corrosion inhibitors have a limited lifetime and contain silicates that can foul or plug the system;
- That galvanized piping is not used in glycol systems since it may lead to the precipitation of certain elements in the glycol's corrosion inhibitor;
- To ensure that the glycol is compatible with the materials used in the system.



**NOTE**

- Be aware of the hygroscopic property of glycol. It absorbs moisture from the environment.
- Leaving the cap off the glycol container causes the concentration of water to increase. The glycol concentration is then lower and the water could freeze.
- Preventive actions must be taken to ensure minimal exposure of the glycol to air.

Also refer to "10.3 Pre-operation checks/Checks before initial start-up"

## 9.4 Filling with water

1. Connect the water supply to the fill valve and open the valve.
2. Make sure the automatic air purge valve is open (at least 2 turns).
3. Fill with water until the manometer indicates a pressure of approximately 2.0 bar. Remove air in the circuit as much as possible using the air purge valves. Air present in the water circuit might cause malfunctioning of the backup heater.

Do not fasten the black plastic cover on the vent valve at the top side of the unit when the system is running. Open vent valve, turn anticlockwise 1 or 2 full turns to release air from the system.

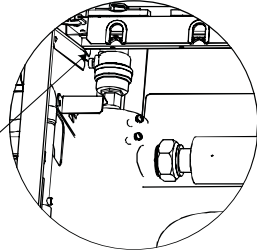

### NOTE

During filling, it might not be possible to remove all air in the system. Remaining air will be removed through the automatic air purge valves during the first operating hours of the system. Topping up the water afterwards might be required.

- The water pressure indicated on the manometer will vary depending on the water temperature (higher pressure at higher water temperature).  
However, at all times water pressure should remain above 0.3 bar to avoid air entering the circuit.
- The unit might drain-off too much water through the pressure relief valve.
- Water quality must be according to "Safe Drinking water Act"

## 9.5 Piping insulation

The complete water circuit including all piping, must be insulated to prevent condensation during cooling operation and reduction of the heating and cooling capacity as well as prevention of freezing of the outside water piping during winter. The thickness of the sealing materials must be at least 13 mm with  $\lambda = 0.039$  W/mK in order to prevent freezing on the outside water piping.

If the temperature is higher than 30°C and the humidity is higher than RH 80%, then the thickness of the sealing materials should be at least 20 mm in order to avoid condensation on the surface of the seal.

## 9.6 Field wiring



### WARNING

- A main switch or other means of disconnection, having a contact separation in all poles, must be incorporated in the fixed wiring in accordance with relevant local laws and regulations.
- Switch off the power supply before making any connections.
- Use only copper wires.
- Never squeeze bundled cables and make sure they do not come in contact with the piping and sharp edges. Make sure no external pressure is applied to the terminal connections.
- All field wiring and components must be installed by a licensed electrician and must comply with relevant local laws and regulations.
- The field wiring must be carried out in accordance with the wiring diagram supplied with the unit and the instructions given below.
- Be sure to use a dedicated power supply. Never use a power supply shared by another appliance.
- Be sure to establish a ground. Do not ground the unit to a utility pipe, surge protector, or telephone ground. Incomplete grounding may cause electrical shock.
- Be sure to install a ground fault circuit interrupter (30 mA). Failure to do so may cause electrical shock.
- Be sure to install the required fuses or circuit breakers.

### 9.6.1 Precautions on electrical wiring work

- Fix cables so that cables do not make contact with the pipes (especially on the high pressure side).
- Secure the electrical wiring with cable ties as shown in figure so that it does not come in contact with the piping, particularly on the high-pressure side.
- Make sure no external pressure is applied to the terminal connectors.
- When installing the ground fault circuit interrupter make sure that it is compatible with the inverter (resistant to high frequency electrical noise) to avoid unnecessary opening of the ground fault circuit interrupter.



### NOTE

The ground fault circuit interrupter must be a high-speed type breaker of 30 mA (<0.1 s).

- This unit is equipped with an inverter. Installing a phase advancing capacitor not only will reduce the power factor improvement effect, but also may cause abnormal heating of the capacitor due to high-frequency waves. Never install a phase advancing capacitor as it could lead to an accident.

### 9.6.2 Overview

The illustration below gives an overview of the required field wiring between several parts of the installation. Refer also to "8 Typical application examples".

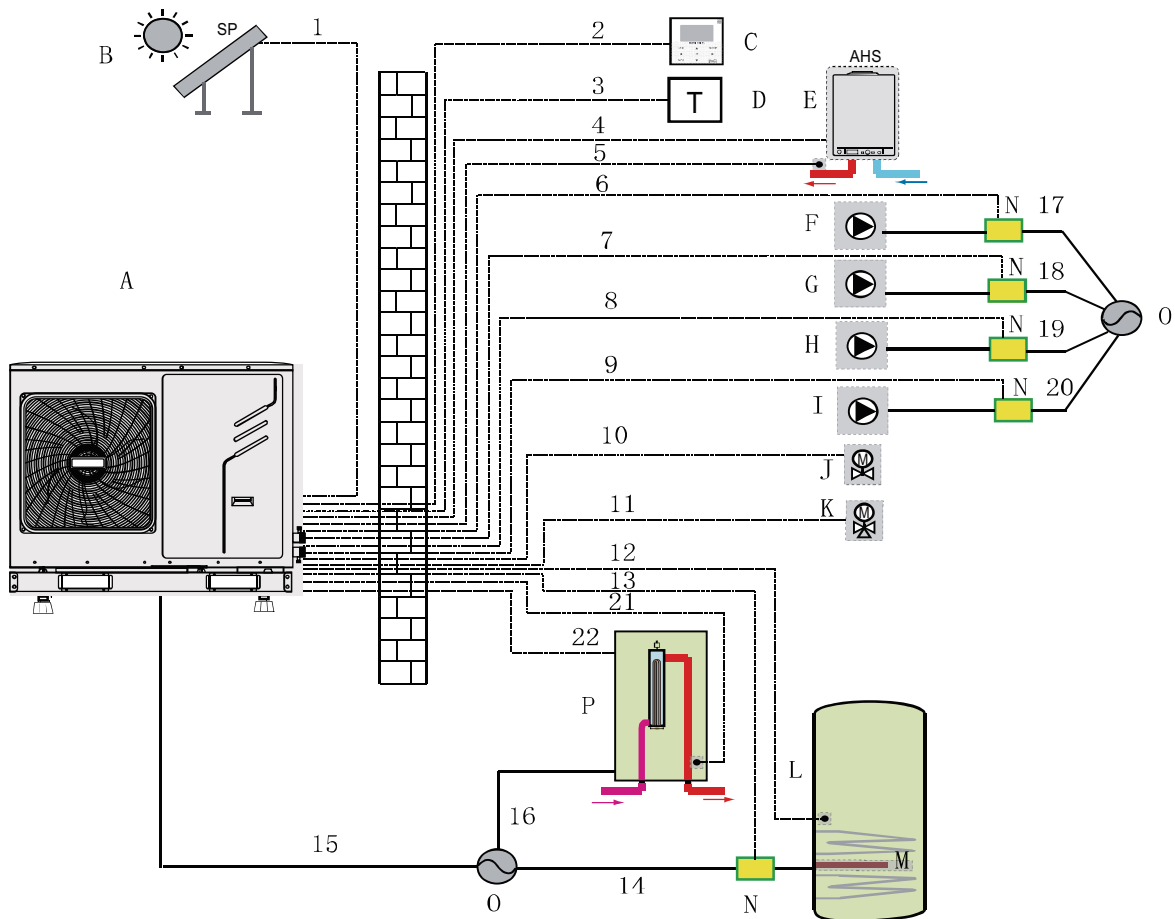
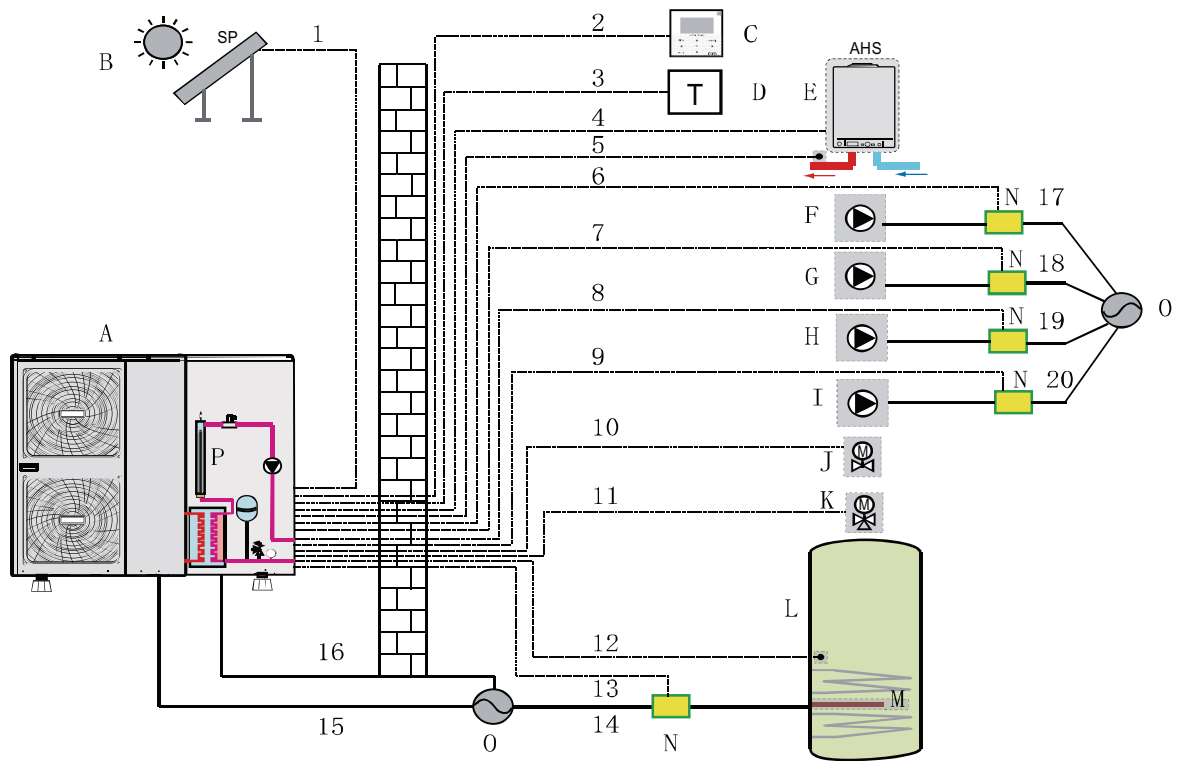

- |                                   |   |                           |
|-----------------------------------|---|---------------------------|
| A Outdoor unit                    | G P_c: Mixing pump (field supply)                             | L Domestic hot water tank |
| B Solar energy kit (field supply) | H P_o: Outside circulation pump (field supply)                | M Booster heater          |
| C User interface                  | I P_d: DHW pump (field supply)                                | N Contactor               |
| D Room thermostat (field supply)  | J SV2: 2-way valve (field supply)                             | O Power supply            |
| E Boiler (field supply)           | K SV1: 3-way valve for domestic hot water tank (field supply) | P Backup heater           |
| F P_s: Solar pump (field supply)  |   |                           |

Item	Description	AC/DC	Required number of conductors	Maximum running current
1	Solar energy kit signal cable	AC	2	200mA
2	User interface cable	AC	5	200mA
3	Room thermostat cable	AC	2 or 3	200mA(a)
4	Boiler control cable	/	2	200mA
5	Thermistor cable for T1B	DC	2	(b)
6	Solar pump control pump	/	2	200mA
7	Mixing pump control cable	/	2	200mA
8	Outside circulation pump control cable	AC	2	200mA(a)
9	DHW pump control cable	AC	2	200mA(a)
10	2-way valve control cable	AC	2	200mA(a)
11	3-way valve control cable	AC	2 or 3	200mA(a)
12	Thermistor cable	DC	2	(b)
13	Booster heater control cable	AC	2	200mA(a)
14	Power supply cable for booster heater	AC	2	200mA(a)
15	Power supply cable for unit	AC	2+GND (1-phase) 3+GND (3-phase)	31A (1-phase) 15A (3-phase)
16	Power supply cable for backup heater	AC	2+GND (1-phase) 3+GND (3-phase)	14A (1-phase) 6A (3-phase)
17	Power supply cable for solar pump	AC	2	200mA(a)
18	Power supply cable for mixing pump	AC	2	200mA(a)
19	Power supply cable for outside circulation pump	AC	2	200mA(a)
20	Power supply cable for DHW pump	AC	2	200mA(a)
21	Thermistor cable	AC	2	200mA(a)
22	Backup heater control cable	AC	2	200mA(a)

(a) Minimum cable section AWG18 (0.75 mm<sup>2</sup>)

(b) The thermistor cable are delivered with the unit

**NOTE:**Please use H07RN-F for the power wire, all the cable are connect to high voltage except for thermistor cable and cable for user interface.

Equipment must be grounded. All high-voltage external loads, if it is metal or a grounded port, must be grounded.

All external loads current is needed less than 1.5A, if the loads current is greater than 1.5A, Single external load current is needed less than 0.2A, if the single load current is greater than 0.2A, the load must be controlled through AC contactor.

"AHS1" "AHS2", "A1" "A2", "R1" "R1" and "DTF1" "DTF2" wiring terminal ports provide only the switch signal.

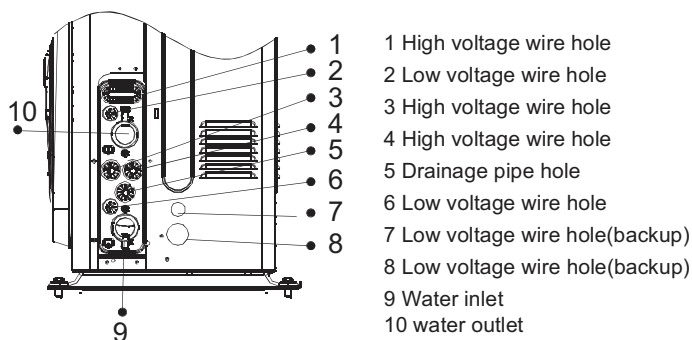

1-phase 10~16kW  
3-phase 12~16kW

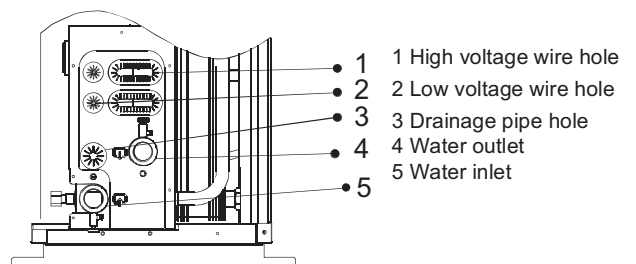

1-phase 5/7 kW

**Field wiring guidelines**

- Most field wiring on the unit is to be made on the terminal block inside the switch box. To gain access to the terminal block, remove the switch box service panel (door 2).

---

**WARNING**

Switch off all power including the unit power supply and backup heater and domestic hot water tank power supply (if applicable) before removing the switch box service panel.

---

- Fix all cables using cable ties.
- A dedicated power circuit is required for the backup heater.
- Installations equipped with a domestic hot water tank (optional) require a dedicated power circuit for the **booster heater**. Please refer to the domestic hot water tank Installation & Owner's Manual.  
*Secure the wiring in the order shown below.*
- Lay out the electrical wiring so that the front cover does not rise up when doing wiring work and attach the front cover securely (see figure).
- Follow the electric wiring diagram for electrical wiring works (the electric wiring diagrams are located on the rear side of door 1).
- Install the wires and fix the cover firmly so that the cover may be fit in properly.

**9.6.3 Precautions on wiring of power supply**

- Use a round crimp-style terminal for connection to the power supply terminal board. In case it cannot be used due to unavoidable reasons, be sure to observe the following instructions.
- Do not connect different gauge wires to the same power supply terminal. (Loose connections may cause overheating.)
  - When connecting wires of the same gauge, connect them according to the figure below.



- Use the correct screwdriver to tighten the terminal screws. Small screwdrivers may damage the screw head and prevent appropriate tightening.
- Over-tightening the terminal screws can damage the screws.
- Attach a ground fault circuit interrupter and fuse to the power supply line.
- In wiring, make certain that prescribed wires are used, carry out complete connections, and fix the wires so that outside force cannot affect the terminals.

**9.6.4 Specifications of standard wiring components**

**Door 1: compressor compartment and electrical parts: XT1**

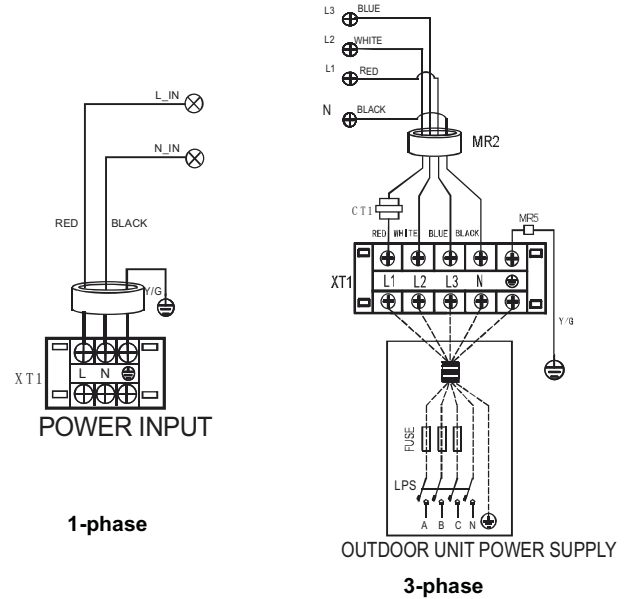

	1-phase 5/7 kW	1-phase 10~16kW	3-phase 12~16kW
Maximum overcurrent protector(MOP)	25	32	25
Wiring size	4 mm <sup>2</sup>	6 mm <sup>2</sup>	4 mm <sup>2</sup>

(a) Stated values are maximum values (see electrical data for exact values).

---

**NOTE**

The ground fault circuit interrupter must be a high-speed type breaker of 30 mA (<0.1 s).

---

**9.6.5 Connection of the backup heater power supply**

**Power circuit and cable requirements**

- Be sure to use a dedicated power circuit for the backup heater. Never use a power circuit shared by another appliance.
- Use the same dedicated power supply for the unit, backup heater and booster heater (domestic hot water tank).



This power circuit must be protected with the required safety devices according to local laws and regulations.  
 Select the power cable in accordance with relevant local laws and regulations. For the maximum running current of the backup heater, refer to the table below.

**Door 2:** electrical parts of the hydraulic compartment, backup heater: **XT5 (3-phase) / XT4 (1-phase)**

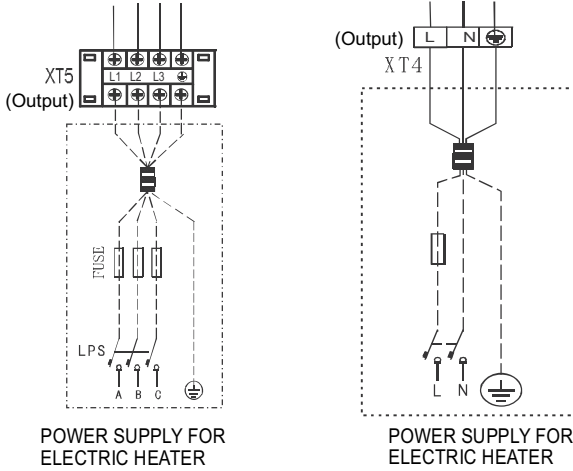

	Backup heater capacity	
	3kW 1-phase	4.5kW 3-phase
Backup heater nominal voltage	220-240VAC	380-415VAC
Minimum circuit amps (MCA)	14.3	14.3
Maximum overcurrent protector (MOP)	20	20



**NOTE**

The ground fault circuit interrupter must be a high-speed type breaker of 30 mA (<0.1 s).

**9.6.6 Connection for other components**

Electrical parts of the hydraulic compartment: The **XT7** contains terminals for solar energy, remote alarm, 2-way valve, 3-way valve, pump, booster heater and external heating source. The parts wiring is illustrated below:

**For solar energy kit**

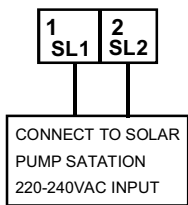

Voltage	220-240VAC
Maximum running current	0.2A
Wiring size	0.75mm <sup>2</sup>

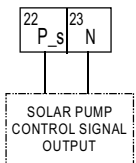

Voltage	220-240VAC
Maximum running current	0.2A
Wiring size	0.75mm <sup>2</sup>

**For remote alarm:**

**REMOTE ALARM**

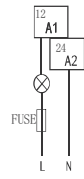

REMOTE ALARM

Voltage	Passive signal port
Maximum running current	0.5A
Wiring size	0.75mm <sup>2</sup>

**Procedure**

1. Connect the cable to the appropriate terminals as shown on the diagram.
2. Fix the cable with cable ties to the cable tie mountings to ensure stress relief.

**For 2-way valve SV2:**

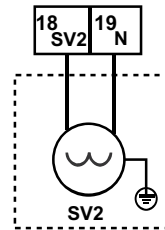

Voltage	220-240VAC
Maximum running current	0.2A
Wiring size	0.75mm <sup>2</sup>

**NOTE:** Only a normal closing valve is available for this unit

**Procedures**

1. Connect the valve cable to the appropriate terminals as shown in the picture
2. Fix the cable with cable ties to the cable tie mountings to ensure stress relief

**For 3-way valve SV1**

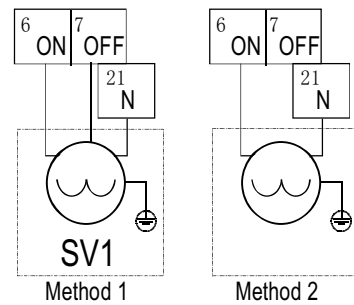

Voltage	220-240VAC
Maximum running current	0.2A
Wiring size	0.75mm <sup>2</sup>



**NOTE:** Wiring of the 3-way valve is different for NC (normal close) and NO (normal open). Before wiring, read the Installation & Owner's manual for the 3-way valve carefully and install the valve as should in the picture. Make sure to connect it to the correct terminal numbers.

**Procedure**

1. Connect the cable to the appropriate terminals as shown in the picture
2. Fix the cable with cable ties to the cable tie mountings to ensure stress relief.

**For remote shutdown:**

**SWITCH SIGNAL INPUT**

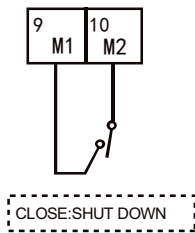

**For tank loop pump P\_d and mix pump P\_c:**

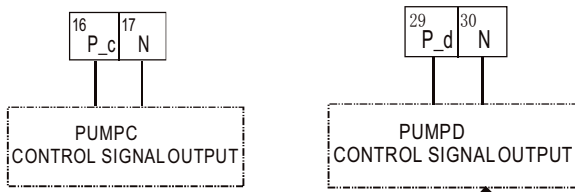

Voltage	220VAC-240VAC	<b>NOTE</b> For 5/7 kW unit, the terminal number is 37 and 38.
Maximum running current	0.2A	
Wiring size	0.75mm <sup>2</sup>	

**Procedure**

1. Connect the cable to the appropriate terminals as shown in the picture.
2. Fix the cable with cable ties to the cable tie mountings to ensure stress relief

**For room thermostat:**

**External ON/OFF thermostat**

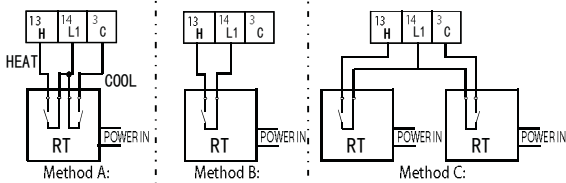

**External thermostat**

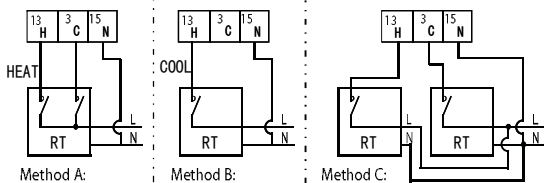

Voltage	220VAC-240VAC
Maximum running current	0.2A
Wiring size	0.75mm <sup>2</sup>

There are three methods for connecting the thermostat cable (as described in the picture above) and it depends on the application. If method "A" is selected, the space operation mode can be selected on the room thermostat. If method "B" is selected, the room thermostat is used as a switch. When the room temperature reaches the target temperature, the units will turn off, while the space operation mode can only be selected on the user interface.

If method "C" is selected, application 6 (refer to 8.6 Application 6) should be applied. Any room thermostat sent ON signal to the unit will the unit turn on. Both room thermostat sent OFF signals to the unit will the unit turn off. The operation mode can be set in the user interface.

When the room thermostat is installed the ON/OFF of the unit is decided by the temperature detected by the thermostat, the user interface can only set the target temperature.

**NOTE:**

1. The wiring of the thermostat should correspond to the settings of the user interface. Refer to 10.7 Field setting/Room Thermostat.
2. Power supply of machine and room thermostat must be connected to the same Neutral Line and (L2) Phase Line (for 3-phase unit only).

**Procedure**

1. Connect the cable to the appropriate terminals as shown on the picture
2. Fix the cable with cable ties to the cable tie mountings to ensure stress relief

**For booster heater:**

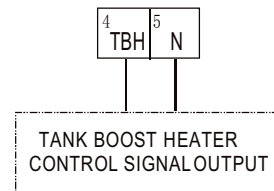

Voltage	220VAC-240VAC
Maximum running current	0.2A
Wiring size	0.75mm <sup>2</sup>

Connection of the booster heater cable depends on the application. Only when the domestic hot water tank is installed will this wiring be needed. The unit only sends a turn on/off signal to the booster heater. An additional circuit breaker is needed and a dedicated terminal is needed to supply power to the booster heater.

See also "8 Typical application examples" and "10.7 Field settings/DHW control" for more information.

**Procedure**

1. Connect the cable to the appropriate terminals as shown on the picture
2. Fix the cable with cable ties to the cable tie mountings to ensure strain relief

**For boiler and pipe pump P\_o:**

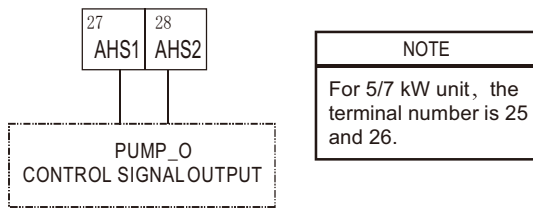

Voltage	220-240VAC
Maximum running current	0.2A
Wiring size	0.75mm <sup>2</sup>

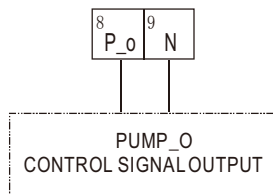

Voltage	220-240VAC
Maximum running current	100mA
Wiring size	0.75mm <sup>2</sup>

**Procedure**

1. Connect the cable to the appropriate terminals as shown on the picture
2. Fix the cable with cable ties to the cable tie mountings to ensure stress relief.

**For external backup heater box (5/7/9kW unit only):**

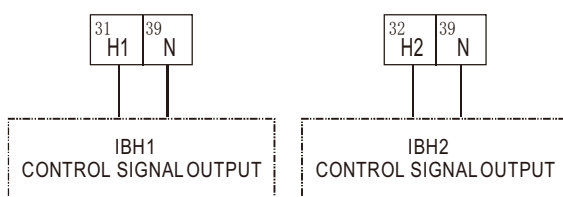

**For user interface:**

**COMMUNICATION**

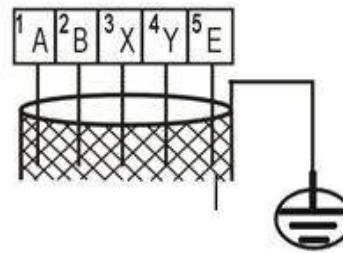
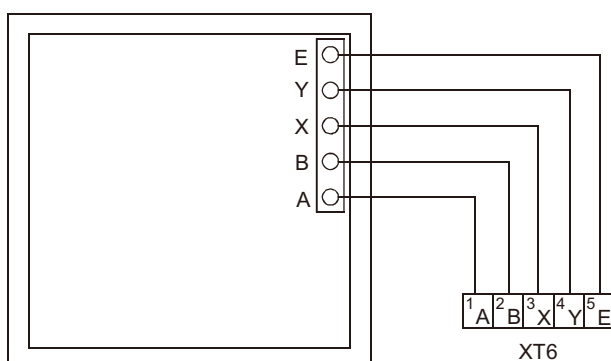

“PLEASE USE SHIELDED WIRE AND EARTH THE WIRE.”

Wire type	5 wire shielded cable
Wire section	AWG18-AWG16(0.75~1.25mm <sup>2</sup> )
Maximum wire length	50m

As described above, during wiring, port A in the unit terminal XT6 corresponds to port A in the user interface. Port B corresponds to port B. Port X corresponds to port X. Port Y corresponds to port Y, and port E corresponds to port E..

**Procedure**

1. Remove the rear part of the user interface.
2. Connect the cable to the appropriate terminals as shown in the picture
3. Reattach the rear part of the user interface

**10 START-UP AND CONFIGURATION**

The unit should be configured by the installer to match the installation environment (outdoor climate, installed options, etc.) and user expertise.



It is important that all information in this chapter is read sequentially by the installer and that the system is configured as applicable.

**10.1 Climate related curves**

The climate related curves can be selected in the user interface (refer to the operation manual, **6.2.2 Weather Temperature set**, if ECO mode is enabled, please refer to the operation manual **6.2.3 ECO Mode**).

Once the curve is selected, the target outlet water temperature is determined by the outdoor temperature. In each mode, you can select one curve from eight curves in the user interface. And it designed for three applications. Floor heating Low temperature / Floor heating High temperature and Radiator. For some new building with good insulation, you can adopt floor heating Low temperature curves. And set corresponding curves in controller. If your building insulation is not so well, you can choose floor heating high temperature curves. If you need relace a boiler for radiator, Please choose radiator curves.

The relationship between outdoor temperature(T4/°C) and target outlet water temperature(T1s/°C) is described in the table and picture in the next page.

The selection of the low/high temperature curve can be done in the user interface. Incool mode refer to 10.7 Field setting/COOL control/How to set the COOL mode. In heat mode refer to 10.7 Field setting/HEAT control/How to set the HEAT mode.

Temperature curves for heating mode:

T1s Curve number	Outdoor Temp. T4										
	-20	-15	-10	-5	0	5	10	15	20	25	35
LOW 1	30	30	30	28	27	25	23	22	20	20	20
LOW 2	34	34	34	32	29	27	25	22	20	20	20
LOW 3	38	38	38	35	32	29	26	23	20	20	20
LOW 4	41	41	41	38	34	31	27	24	20	20	20
LOW 5	45	45	45	41	37	33	28	24	20	20	20
LOW 6	49	46	44	42	39	37	35	32	30	30	30
LOW 7	51	49	46	43	41	38	35	33	30	30	30
LOW 8	54	51	48	45	42	39	36	33	30	30	30
HIGH 1	55	53	50	47	43	40	37	33	30	30	30
HIGH 2	55	55	52	48	45	41	37	34	30	30	30
HIGH 3	55	55	54	50	46	42	38	34	30	30	30
HIGH 4	46	46	46	43	39	36	32	29	25	25	25
HIGH 5	50	50	50	46	42	38	33	29	25	25	25
HIGH 6	53	53	53	48	44	39	34	30	25	25	25
HIGH 7	57	57	57	52	46	41	36	30	25	25	25
HIGH 8	60	60	60	54	48	42	37	31	25	25	25

Temperature curves for heating ECO mode:

T1s Curve number	Outdoor Temp. T4										
	-20	-15	-10	-5	0	5	10	15	20	25	35
ECO-LOW 1	25	25	25	23	22	20	20	20	20	20	20
ECO-LOW 2	29	29	29	26	24	22	20	20	20	20	20
ECO-LOW 3	32	32	32	29	26	24	21	20	20	20	20
ECO-LOW 4	36	36	36	32	29	25	22	20	20	20	20
ECO-LOW 5	39	39	39	35	31	27	23	20	20	20	20
ECO-LOW 6	45	42	39	37	34	32	30	30	30	30	30
ECO-LOW 7	48	44	41	38	36	33	30	30	30	30	30
ECO-LOW 8	50	46	43	40	37	34	31	30	30	30	30
ECO-HIGH 1	50	48	45	42	38	35	32	30	30	30	30
ECO-HIGH 2	50	50	47	43	40	36	32	30	30	30	30
ECO-HIGH 3	50	50	49	45	41	37	33	30	30	30	30
ECO-HIGH 4	41	41	41	38	34	31	27	25	25	25	25
ECO-HIGH 5	45	45	45	40	36	32	28	25	25	25	25
ECO-HIGH 6	48	48	48	43	39	34	29	25	25	25	25
ECO-HIGH 7	52	52	52	46	41	36	31	26	25	25	25
ECO-HIGH 8	55	55	55	49	43	37	32	27	25	25	25

Temperature curves for cooling mode:

T1s Curve number	Outdoor Temp. T4			
	-5 ~ 14	15 ~ 21	22 ~ 29	30 ~ 46
LOW 1	18	13	10	7
LOW 2	19	14	11	8
LOW 3	20	15	12	9
LOW 4	21	16	13	10
LOW 5	22	17	14	11
LOW 6	23	18	15	12
LOW 7	24	19	16	13
LOW 8	25	21	18	14
HIGH 1	20	18	18	18
HIGH 2	21	19	18	18
HIGH 3	22	20	18	18
HIGH 4	23	21	18	18
HIGH 5	24	22	20	18
HIGH 6	25	23	21	19
HIGH 7	25	24	22	20
HIGH 8	25	25	23	21

### 10.2 DIP switch settings overview

DIP switch 26 is located on the switch box PCB (see "9.2 main components/Switch box main components (door 2)") and allows configuration of additional heating source thermistor installation, the second inner backup heater installation, etc.



### WARNING

Switch off the power supply before opening the switch box service panel and making any changes to the DIP switch settings.

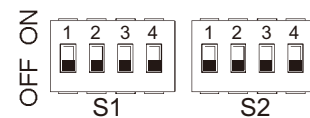

DIP switch	Description	ON	OFF
S1	1 Selection of refrigerant pipe length	Reserved	Reserved
	2 Backup heater outlet temperature thermistor installation	Installed	Installed
	3 The first inner backup heater installation	Not installed	Installed
	4 The second inner backup heater installation	Not installed	Installed
S2	1 Additional heating source outlet temperature thermistor installation	Installed	Not installed
	2 /	/	/
	3 /	/	/
	4 /	/	/

### 10.3 Initial start-up at low outdoor ambient temperatures

During initial start-up and when water temperature is low, it is important that the water is heated gradually. Failure to do so may result in concrete floors cracking due to rapid temperature change. Please contact the responsible cast concrete building contractor for further details.

To do so, the lowest water flow set temperature can be decreased to a value between 25°C and 35°C by adjusting the FOR SERVICEMAN. Refer to "FOR SERVICEMAN/special function/preheating for floor" on page 45.

**10.4 Pre-operation checks**

**Checks before initial start-up**

---

 **DANGER**

---

Switch off the power supply before making any connections.

---

After the installation of the unit, check the following before switching on the circuit breaker:

1. Field wiring  
Make sure that the field wiring between local supply panel and unit and valves (when applicable), unit and room thermostat (when applicable), unit and domestic hot water tank, and unit and backup heater box have been carried out according to the instructions described in the chapter "Field wiring", according to the wiring diagrams and according to local laws and regulations.
2. Fuses, circuit breakers, or protection devices  
Check that the fuses or the locally installed protection devices are of the size and type specified in the chapter "Technical specifications". Make sure that neither a fuse nor a protection device has been bypassed.
3. Backup heater circuit breaker  
Do not forget to turn on the backup heater circuit breaker in the switchbox (it depends on the backup heater type). Refer to the wiring diagram.
4. Booster heater circuit breaker  
Do not forget to turn on the booster heater circuit breaker (applies only to units with optional domestic hot water tank installed).
5. Ground wiring  
Make sure that the ground wires have been connected properly and that the ground terminals are tightened.
6. Internal wiring  
Visually check the switch box on loose connections or damaged electrical components.
7. Fixation  
Check that the unit is properly fixed, to avoid abnormal noises and vibrations when starting up the unit.
8. Damaged equipment  
Check the inside of the unit on damaged components or squeezed pipes.
9. Refrigerant leak  
Check the inside of the unit on refrigerant leakage. If there is a refrigerant leak, call your local dealer.
10. Power supply voltage  
Check the power supply voltage on the local supply panel. The voltage must correspond to the voltage on the identification label of the unit.
11. Air purge valve  
Make sure the air purge valve is open (at least 2 turns).
12. Shut-off valves  
Make sure that the shut-off valves are fully open

---

 Operating the system with closed valves will damage the circulated pump!

---

**10.5 Powering up the unit**

When power supply to the unit is turned on, "1%~99%" is displayed on the user interface during its initialisation. During this process the user interface cannot be operated.

**10.6 Setting the pump speed**

The pump speed can be selected by adjust the red nob on the pump, the place that notch point to indicate the speed of the pump.



The default setting is the highest speed (III). If the water flow in the system is too high the speed can be set to low speed (I).

The available external static pressure in function of the water flow is shown in the graph below.

Constant speed I II III

**Models 5 to 9kW**

**available external static pressure VS flowrate (5/7/9kW)**

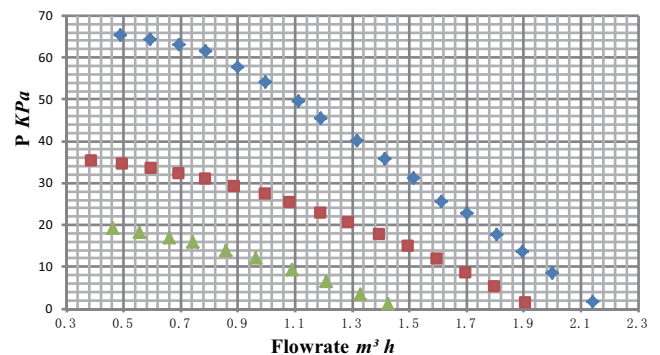

**Models 10 to 16kW**

**available external static pressure VS flowrate (1-phase 10-16kW + 3-phase 12~16kW)**

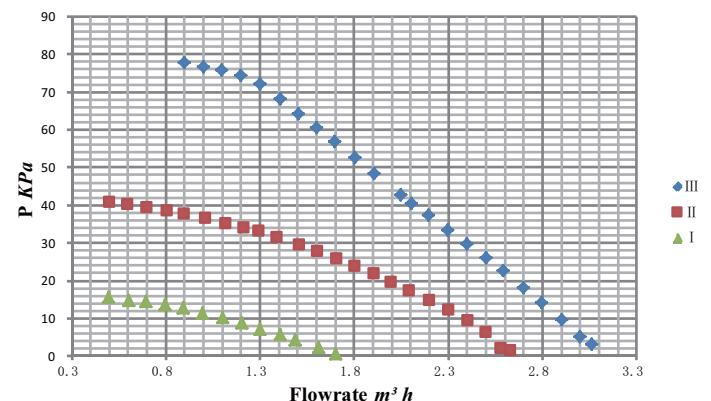

**Pump LED diagnosis and solutions**

The pump has an LED operating status display. This makes it easy for the technician to search for the cause of a fault in the heating system.

1. If the LED display lights up continuously green, it means the pump is running normally.
2. If the LED display is flashing green, it means the pump is running the venting function. The pump runs during the 10 minute venting function. After its cycle, the installer needs to adjust the targeted performance.
3. If the LED is flashing green/red, it means that the pump has stopped operating due to an external reason. The pump will restart by itself after the abnormal situation disappears. The probable reason causing the problem is pump undervoltage or overvoltage (U<160V or U>280V), and you should check the voltage supply. Another reason is module overheating, and you should check the water and ambient temperatures.
4. If the LED is flashing red, it means the pump has stopped operating, and a serious fault has happened (e.g. pump blocked). The pump cannot restart itself due to a permanent failure and the pump should be changed.
5. If the LED does not light up, it means no power supply to the pump, possibly the pump is not connected to power supply. Check the cable connection. If the pump is still running, it means the LED is damaged. Or the electronics are damaged and the pump should be changed.

**Failure diagnosis at the moment of first installation**

- If nothing is displayed on the user interface, it is necessary to check for any of the following abnormalities before diagnosing possible error codes.
  - Disconnection or wiring error (between power supply and unit and between unit and user interface).
  - The fuse on the PCB may have blown.
- If the user interface shows "E8" or "E0" as an error code, there is a possibility that there is air in the system, or the water level in the system is less than the required minimum.
- If the error code E2 is displayed on the user interface, check the wiring between the user interface and unit.

More error code and failure causes can be found in **13.3 Error codes**.

**10.7 Field settings**

The unit shall be configured by the installer to match the installation environment (outdoor climate, installed options, etc.) and user demand. A number of field settings are available. These settings are accessible and programmable through "FOR SERVICEMAN" in user interface.

**Procedure**

To change one or more field settings, proceed as follows.



Temperature values displayed on the digital controller (user interface) are in °C

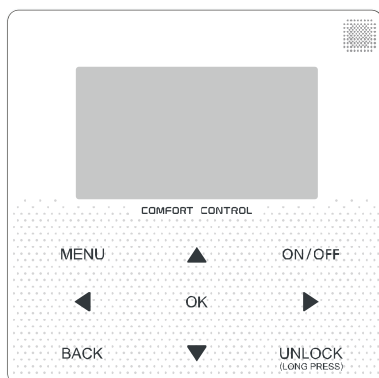

Keys	Function
<b>MENU</b>	• Go to the menu structure (on the home page)
◀ ▶ ▼ ▲	• Navigate the cursor on the display • Navigate in the menu structure • Adjust settings
<b>ON/OFF</b>	• Turn on/off the space heating/cooling operation mode or DHW mode • Turn on/or off functions in the menu structure
<b>BACK</b>	• Come back to the up level
<b>UNLOCK</b>	• Long press for unlock /lock the controller • Unlock /lock some functions such as "DHW temperature adjusting "
<b>OK</b>	• Go to the next step when programming a schedule in the menu structure; and confirm a selection to enter in the submenu of the menu structure.

**10.7.1 FOR SERVICEMAN**

"FOR SERVICEMAN" is designed for the installer to set the parameter.

1. Setting the composition of equipment.
2. Setting the parameter.

**How to go to FOR SERVICEMAN**

Go to MENU> FOR SERVICEMAN. Press OK

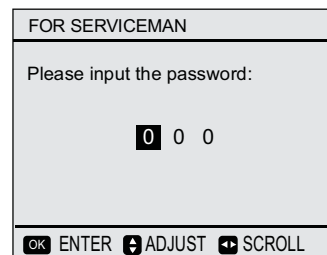

The password is 666. Use ◀ ▶ to navigate and use ▼ ▲ to adjust the numerical value. Press OK. The following page is displayed:

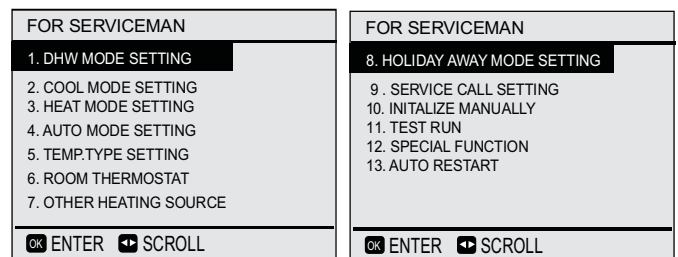

Use ▼ ▲ to scroll and use "ok" to enter submenu for setting the parameters.

**10.7.2 DHW control**

**About DHW mode**

DHW domestic hot water

DHW MODE SETTING typically consists of the following :

1. DHW MODE: enable or disable the DHW mode
  2. TANK HEATER: set whether the booster heater available or not
  3. DISINFECT: set the parameters for disinfection
  4. DHW PRIORITY: set the priority between domestic hot water heating and space operation
  5. DHW PUMP: set the parameters for DHW pump operation
- The above functions applies only to installations with a domestic hot water tank.

**How to set the DHW mode**

To determine whether the DHW mode is effective.

Go to MENU> FOR SERVICEMAN> DHW MODE SETTING .Press OK. The following page will appear.



1 DHW MODE SETTING	
1.1. DHW MODE	<input checked="" type="checkbox"/> YES <input type="checkbox"/> NON
1.2. TANK HEATER	<input checked="" type="checkbox"/> YES <input type="checkbox"/> NON
1.3. DISINFECT	<input checked="" type="checkbox"/> YES <input type="checkbox"/> NON
1.4. DHW PRIORITY	<input checked="" type="checkbox"/> YES <input type="checkbox"/> NON
1.5. DHW PUMP	<input type="checkbox"/> YES <input checked="" type="checkbox"/> NON
OK ENTER    ⬅️ SCROLL	

Use ◀ ▶ to scroll and OK for enter. When the cursor is on  press YES, Press OK to set the DHW MODE as effective. When the cursor is on  NON,press OK to set the DHW MODE as ineffective.

1. Go to MENU> FOR SERVICEMAN>DHW MODE SETTING>1.1 DHW MODE

1.1 DHW MODE	
dT5_ON	5°C
dT1S5	10°C
T4DHWMAX	43°C
T4DHWMIN	-10°C
t INTERVAL DHW	5 MIN
⬅️ ➡️ SCROLL	

Use ◀ ▶ and ▼ ▲ to scroll and adjust parameters. Use BACK to exit.

dT5\_ON is the temperature difference for starting the heat pump, the picture below illustrates the dT5\_ON function.

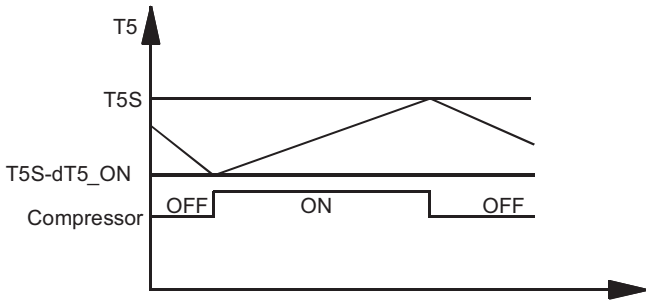

T5S is the target temperature for domestic hot water. T5 is the actual temperature of domestic hot water. When T5 drops to a certain temperature ( $T5 \leq T5S - dT5\_ON$ ) the heat pump will be available.

dT1S5 is the correct value for the target outlet water temperature ( $T1S = T5 + dT1S5$ ).

T4DHWMAX is the maximum ambient temperature that the heat pump can operate at for domestic water heating. The unit will not operate if the ambient temperature goes above it in DHW mode.

T4DHWMIN is the minimum ambient temperature that the heat pump can operate for domestic water heating. The heat pump will turn off if the ambient temperature drops below it in water heating mode. The relationship between operation of the unit and ambient temperature can be illustrated in the picture below:



T\_INTERVAL\_DHW is the start time interval of the compressor in DHW mode. When the compressor stops running, the next time the compressor turns on it should be T\_INTERVAL\_DHW plus one minute later at least.

Go to FOR SERVICEMAN>DHW MODE SETTING>1.2 TANK HEATER

1.2 TANK HEATER	
dT5_TBH_OFF	5°C
T4_TBH_ON	20°C
t_TBH_DELAY	90 MIN
⬅️ ➡️ SCROLL	

Use ◀ ▶ and ▼ ▲ to scroll and adjust parameters. Use BACK to exit.

dT5\_TBH\_OFF is the temperature difference between T5 and T5S that turns the booster heater off. The booster heater will turn off ( $T5 \geq T5S + dT\_TBH\_OFF$ ) when the heat pump malfunctions.

T4\_TBH\_ON is the temperature only when the ambient temperature is lower than its parameter and the booster heater will be available. t\_TBH\_DELAY is the time that the compressor has run before starting the booster heater (if  $T5 < \min(T5S, T5stop)$ ). The operation of the unit during DHW mode described in the picture below:

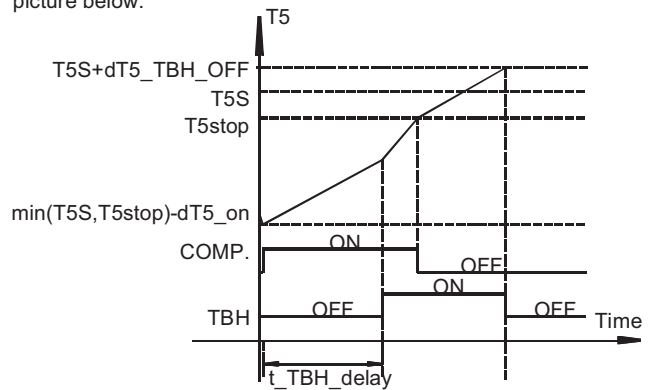

In the picture, T5stop is a parameter related to ambient temperature, which cannot be changed in the user interface. When  $T5 \geq T5stop$ , the heat pump will turn off.

Note: the booster heater and backup heater can't operate simultaneously, if the booster heater has been on, the backup heater will be off.

If the booster heater is unavailable (1.2 TANK HEATER NON is selected), the dT5\_ON cannot be adjusted and is fixed at 2.

3. Go to MENU> FOR SERVICEMAN>DHW MODE SETTING>1.3 DISINFECT

1.3 DISINFECT	
T5S_DI	5°C
t_DI_HIGHTEMP.	30 MIN
t_DI_MAX	120 MIN
⬅️ ➡️ SCROLL	

Use ◀ ▶ ▼ ▲ to scroll and adjust parameters. Use BACK to exit.

T5S\_DI is the target temperature of water in the domestic hot water tank in the DISINFECT function.

t\_DI\_HIGHTEMP is the time that the hot water will last.

t\_DI\_MAX is the time that disinfection will last. The change of domestic water temperature is described in the picture below:

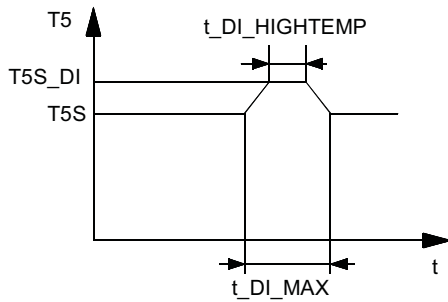

Be aware that the domestic hot water temperature at the hot water tap will be equal to the value selected in FOR SERVICEMAN "T5S\_DI" after a disinfection operation.



**WARNING**

If this high domestic hot water temperature can be a potential risk for human injuries, a mixing valve (field supply) should be installed at the hot water outlet connection of the domestic hot water tank. This mixing valve will ensure that the hot water temperature at the hot water tap never rises above a set maximum value. This maximum allowable hot water temperature shall be selected according to local laws and regulations.

4. Go to SERVICEMAN>DHW MODE SETTING>1.4DHW PRIORITY:

1.4 DHW PRIORITY	
t_DHWHP_MAX	180MIN
t_DHWHP RESTRICT	180MIN
SCROLL	

The function of the DHW PRIORITY is used to set the operation priority between domestic water heating and space (heating/cooling) operation. You can use ◀▶ and ▼▲ to scroll and adjust parameters. Using BACK to exit.

T\_DHWHP\_MAX is the maximum continuous working period of the heat pump in DHW PRIORITY mode.

T\_DHWHP\_RESTRICT is the operation time for the space heating/cooling operation.

If DHW PRIORITY is enabled, the operation of the unit can be described in the picture below

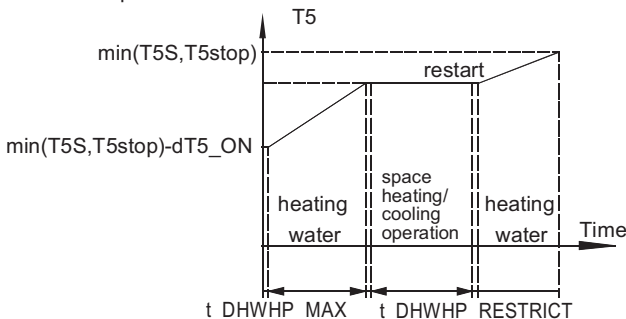

If NON is selected in the DHW PRIORITY mode, when it is available and the space heating/cooling is OFF, the heat pump will heat the water as required. If space heating/cooling is ON, the water will be heated as required when the booster heater is unavailable. Only when the space heating/cooling is OFF will the heat pump operate to heat domestic water.

1.5 DHW PUMP	
TIMER RUNNING	ON
DISINFECT	ON
PUMP RUNNING TIME	10MIN
ON/OFF ON/OFF SCROLL	

Go to FOR SERVICEMAN>DHW MODE SETTING>1.5DHW PUMP You can use ◀▶ and ▼▲ to scroll and adjust parameters. Use BACK to exit.

When the **TIMER RUNNING** is ON, the DHW pump will run as timed and keeps running for an certain time (as defined in **PUMP RUNNING TIME**).

When **DISINFECT** is ON, the DHW pump will operate when the unit is in disinfect mode and  $T5 \geq T5S\_DI - 2$ . Pump run time is  $t + 5\text{min}$ .

**10.7.3 COOL MODE SETTING**

**About COOL MODE SETTING**

COOL MODE SETTING typically consists of the following :

1. COOL MODE: Setting the COOL mode effective or non-effective
2. T1S RANGE: Selecting the range of target outlet water temperature
3. T4CMAX: Setting the maximum ambient operation temperature
4. T4CMIN: Setting the minimum ambient operating temperature
5. dT1SC: Setting the temperature difference for starting the heat pump
6. t\_INTERVAL\_C: Setting the compressor start time interval

**How to set the COOL mode**

To determine whether the COOL mode is effective, go to MENU> FOR SERVICEMAN> COOL MODE SETTING. Press OK. The following page will be displayed:

2 COOL MODE SETTING	
COOL MODE	<input checked="" type="checkbox"/> YES <input type="checkbox"/> NON
T1S RANGE	<input checked="" type="checkbox"/> LOW <input type="checkbox"/> HIGH
T4CMAX	43°C
T4CMIN	20°C
dT1SC	5°C
SCROLL 1/2	

2 COOL MODE SETTING	
dTSC	2°C
t_INTERVAL_C	5MIN
SCROLL 2/2	

When the cursor is on COOL MODE, Use ◀▶ to select YES or NON. Then press OK to enable or disable the cool mode. When the cursor is on T1S RANGE. Use ◀▶ to select the range of outlet water temperature. When LOW is selected, the minimum target temperature is 5°C. If the climate-related curve function (corresponds to "weather temperature set" in the user interface) is enabled, the curve selected is the low temperature curve. When HIGH is selected, the minimum target temperature is 18°C, if the climate-related curve function (corresponds to "weather temperature set" in the user interface) is enabled, the curve selected is the high temperature curve.

When the cursor is on T4CMAX、T4CMIN、dT1SC、dTSC or t\_INTERVAL\_C, Use ◀▶ and ▼▲ to scroll and adjust the parameter. T4CMAX is the maximum ambient temperature in COOL mode. The unit cannot work if the ambient temperature is higher. T4CMIN is the minimum ambient operating temperature in COOL mode. The unit will turn off if the ambient temperature drops below it. The relationship between the operation of the unit and ambient temperature is shown in the picture below:

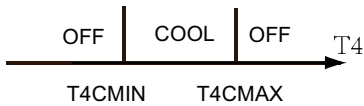

dT1SC is the temperature difference between T1 (actual outlet water temperature) and T1S (target outlet water temperature) for starting the unit in cool mode. Only when T1 is high enough will the unit turn on, and will turn off if T1 drops to a certain value. See the diagram below:

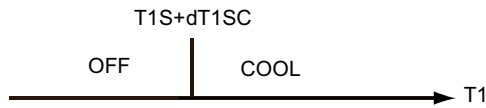

In the picture  $\Delta T$  is a parameter related to ambient temperature, it can't be changed in the user interface. dTSC is the temperature difference between Ta (actual room temperature) and TS (target room temperature). To start the unit when ROOM TEMP is enabled in TEMP.TYPE SETTING (refer to 10.7 Field setting/TEMP.TYPE SETTING). Only when the Ta is high is enough will the unit turn on, and the unit will turn off if the Ta drops to a certain value. Only when the room thermostat is available will this function be available. See picture below:

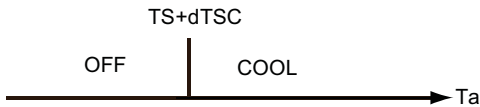

**10.7.4 HEAT MODE SETTING**

**About HEAT MODE SETTING**

HEAT MODE SETTING mode typically consists of the following:

1. HEAT MODE: Enable or disable the HEAT mode
2. T1S RANGE: Selecting the range of setting outlet water temperature
3. T4HMAX: Setting the maximum ambient operating temperature
4. T4HMIN: Setting the minimum operating ambient operating temperature
5. dT1SH: Setting the temperature difference for starting the unit
6. t\_INTERVAL\_H: Setting the compressor start time interval

**How to set the Heat mode**

To determine whether the HEAT mode is effective, go to MENU> FOR SERVICEMAN> HEAT MODE SETTING. Press OK. The following page be displayed:

<b>5 HEAT MODE SETTING</b>	
HEAT MODE	<input checked="" type="checkbox"/> YES <input type="checkbox"/> NON
T1S RANGE	<input checked="" type="checkbox"/> LOW <input type="checkbox"/> HIGH
T4HMAX	25°C
T4HMIN	-15°C
dT1SH	5°C
◀ ▶ SCROLL	

When the cursor is on HEAT MODE, Use ◀▶ to scroll to YES or NON and press OK to enable or disable the heat mode. When the cursor is on the T1S RANGE, use ◀▶ to scroll to YES or NON and press OK to select the range of outlet water temperature. When LOW is selected, the maximum target temperature is 55°C. If the climate-related curve function (corresponds to "weather temperature set" in the user interface) is enabled, the curve selected is the low temperature curve. When HIGH is selected, the maximum target temperature is 60°C. If the climate-related curve function (corresponds to "weather temperature set" in the user interface) is enabled, the curve selected is the high temperature curve.

When the cursor is on T4HMAX、T4HMIN、dT1SH、dTSH or t\_INTERVAL\_H, Use ◀▶ and ▼▲ to scroll and adjust the parameter.

T4HMAX is the maximum ambient operating temperature for heat mode. The unit will not work if the ambient temperature is higher.

T4HMIN is the minimum ambient operating temperature for heat mode. The unit will turn off if the ambient temperature is lower. The relationship between the operation of the unit and ambient temperature can be seen in the picture below:



dT1SH is the temperature difference between T1 and T1S for starting the unit in heat mode. When the target outlet water temperature T1S<47, the unit will turn on or off as described below ( $\Delta T$  is a parameter related to T1S and cannot be changed on the user interface):



When the target outlet water temperature T1S≥47, the unit will on or off as described below

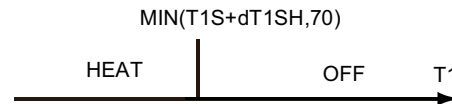

dTSH is the temperature difference between Ta (Ta is the room temperature) and TS for starting the unit when ROOM TEMP is enabled in TEMP.TYPE SETTING (refer to 10.7 Field setting/TEMP.TYPE SETTING). Only when Ta drops to a certain value will the unit turn on, and the unit will turn off if the Ta high enough. See diagram below. (only when room thermostat is available will this function be available).

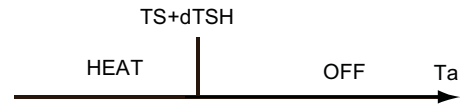

t\_INTERVAL\_H is the compressor start time interval in heat mode. When the compressor stops running, the next time that the compressor turns on should be "t\_INTERVAL\_H" and one minute later at least.

**10.7.5 AUTO MODE SETTING**

**About AUTO SETTING**

Controlling AUTO mode typically consists of the following

1. T4AUTOCMIN setting the minimum operating ambient temperature for cooling
2. T4AUTOHMAX: setting the maximum operating ambient temperature for heating

**How to set the AUTO mode**

To determine whether the AUTO mode is effective, go to MENU> FOR SERVICEMAN> AUTO MODE SETTING. Press OK. The following page is displayed.

<b>4 AUTO MODE SETTING</b>	
T4AUTOCMIN	25°C
T4AUTOHMAX	17°C
◀ ▶ SCROLL	

Use ◀ ▶ and ▼ ▲ to scroll and adjust the parameter.

T4AUTOCMIN is the minimum operating ambient temperature for cooling in auto mode. The unit will turn off if the ambient temperature is lower when in space cooling operation.

T4AUTOHMAX is the maximum operating ambient temperature for heating in auto mode. The unit will turn off if the ambient temperature is higher when in space heating operation.

The relationship between heat pump operation and ambient temperature is described in the picture below

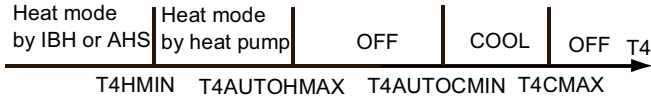

In the picture, AHS is an additional heating source. IBH is a backup heater in the unit.

10.7.6 TEMP. TYPE SETTING

About TEMP. TYPE SETTING

The TEMP. TYPE SETTING is used for selecting whether the water flow temperature or room temperature to control the heat pump is ON/OFF.

When ROOM TEMP. is enabled, the target outlet water temperature will be calculated from climate-related curves.

How to enter the TEMP. TYPE SETTING

To enter the TEMP. TYPE SETTING, go to MENU> FOR SERVICEMAN> TEMP. TYPE SETTING. Press OK. The following page is displayed:

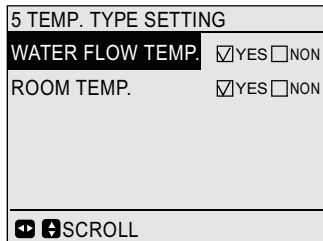

If you set WATER FLOW TEMP. to YES, and set ROOM TEMP. to NON, the water flow temperature will be displayed on the home page, and the water flow temperature will work as the target temperature.

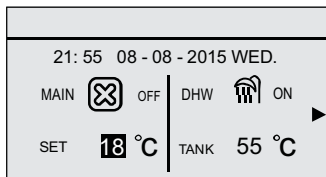

If you set WATER FLOW TEMP. to YES, and set ROOM TEMP. to YES, then the water temperature will be displayed on the home page. Both water temperature and room temperature will be detected and when either the water temperature or the room temperature reaches the target temperature it will the unit turn off.

In this state, the first target outlet water temperature can be set in the main page, the second one can be calculated from the climate-related curves. In heat mode, the higher one will be the real target outlet temperature, while in cool mode, the lower one will be selected.

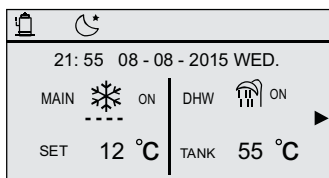

If ▶ is pressed, the main page will display the room temperature:

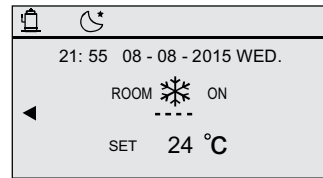

If you set WATER FLOW TEMP. to NON, and set ROOM TEMP. to YES, then the room temperature will be displayed on the home page, and the room temperature will work as the target temperature. The target outlet water temperature can be calculated from the climate related curves.

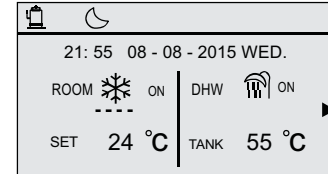

10.7.7 ROOM THERMOSTAT

About ROOM THERMOSTAT

The ROOM THERMOSTAT is used to set whether the room thermostat is available.

How to set the ROOM THERMOSTAT

To set the ROOM THERMOSTAT, go to MENU> FOR SERVICEMAN> ROOM THERMOSTAT. Press OK. The following page is displayed:

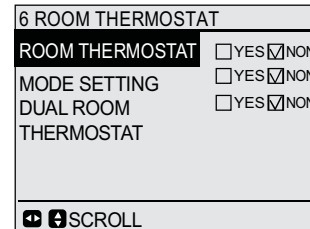

If the room thermostat is available, select YES and press OK. In MODE SETTING, if YES is selected, the mode setting and the on/off function cannot be performed from the user interface. The timer function is unavailable; the running mode, and the on/off function is decided by the room thermostat. The temperature setting can be done by the user interface. If NON is selected, the user interface can be used to set operation mode and target temperature, while the on/off function is determined by room thermostat; the timer function is unavailable. In DUAL ROOM THERMOSTAT, if YES is selected, the ROOM THERMOSTAT, MODE SETTING will turn to NON automatically, and the WATER FLOW TEMP. and ROOM TEMP. is forcibly set to YES. The timer function in the user interface is unavailable. The setting of operation mode and target temperature can be done on the user interface.

The "DUAL ROOM THERMOSTAT" function can be used only when application 6 (refer to 8.6 Application 6) is applied. If zone A requires heating/cooling (ON signal from room thermostat 5A), the unit will turn on. The operation mode and target temperature of outlet water should be set in the user interface. If zone B requires heating/cooling (ON signal from room thermostat 5B), the unit will turn on. The operation mode can be set in the user interface, the target temperature of outlet water will be decided by ambient temperature (target outlet water temperature is calculated from climate-related curves, if no curves are selected, the default curve will be curve 4). If no heating/cooling is required for both zone A and zone B (OFF signal from thermostat 5A and 5 heat by heat pump only B), the unit will turn off.

NOTE The setting in the user interface should correspond to the wiring of thermostat. If YES is selected in ROOM THERMOSTAT and the MODE SETTING is NON, the wiring of thermostat should follow method A. If the MODE SETTING is YES, then the wiring should follow method B if "DUAL ROOM THERMOSTAT" is selected, the wiring of room thermostat should follow "method C" . (refer to "9.6.6 Connection for other components/For room thermostat")

10.7.8 OTHER HEATING SOURCE

About OTHER HEATING SOURCE

The OTHER HEATING SOURCE is used to set whether the backup heater, and additional heating sources like a boiler or solar energy kit is available.

**How to set the OTHER HEATING SOURCE**

To set the OTHER HEATING SOURCE, go to MENU> FOR SERVICEMAN> OTHER HEATING SOURCE, Press OK. The following page will appear:

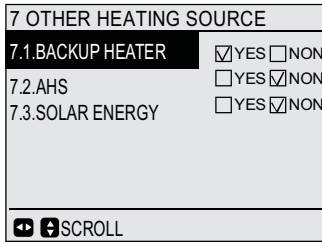

If backup heater is available, please select YES at BACKUP HEATER, then you press OK, the following page will appear:

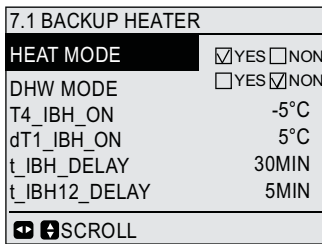

When the cursor is on HEAT MODE or DHW MODE, Using ◀ ▶ to select YES or NON, if YES is selected, the backup heater will be available in corresponding mode, otherwise it will be unavailable.

When the cursor is on T4\_IBH\_ON dT1\_IBH\_ON t\_IBH\_DELAY or t\_IBH12\_DELAY, Using ◀ ▶ ▼ ▲ to scroll and adjust the parameter.

T4\_IBH\_ON is the ambient temperature for starting backup heater, the ambient temperature above which the backup heater will be unavailable, the relationship between operation of the backup heater and the ambient temperature can be described in the picture below.

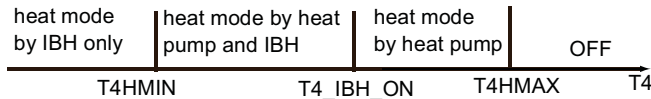

dT1\_IBH\_ON is the temperature difference between T1S and T1 for starting the backup heater. only when  $T1 < T1S - dT1\_IBH\_ON$  can the backup heater turn on. When the second backup heater is installed, if the temperature difference between T1S and T1 large than  $dT1\_IBH\_ON + 2$ , the second backup heater will turn on. the relationship between operation of the backup heater and the temperature difference can be described in the picture below.

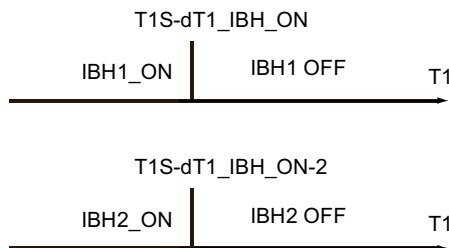

t\_IBH\_DELAY is the time that the compressor has run before the first backup heater turn on(if  $T1 < T1S$ ).

t\_IBH12\_DELAY is the time that the first backup heater has run before the second backup heater turn on.

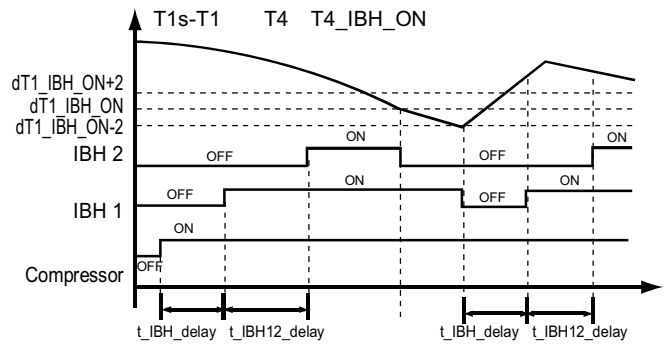

If additional heating source is available, please select YES at the corresponding position, then you press OK, the following page will appear:

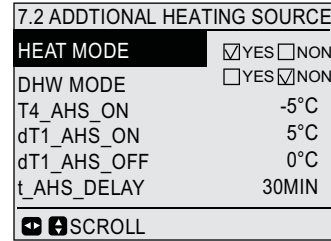

When the cursor is on HEAT MODE or DHW MODE, Using ◀ ▶ to select YES or NON, if YES is selected, the additional heating source will be available in corresponding mode, otherwise it will be unavailable.

**NOTE:**if YES selected in DHW MODE the installation of additional heating source should follow "8.5 Application 5/Application b"

When the cursor is on T4\_AHS\_ON dT1\_AHS\_ON dT1\_AHS\_OFF or t\_AHS\_DELAY, Using ◀ ▶ ▼ ▲ to scroll and adjust the parameter.

T4\_AHS\_ON is the ambient temperature for starting the additional heating source, when the ambient temperature above which the additional heating source will be unavailable. The relationship between the operation of additional heating source and ambient temperature can be described in the picture below:

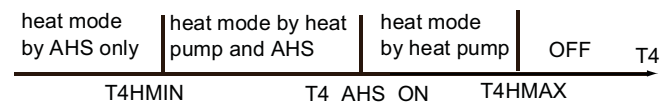

dT1\_AHS\_ON is the temperature difference between T1S and T1 for turning the additional heating source on(only when  $T1 < T1S - dT1\_AHS\_ON$ )

dT1\_AHS\_OFF is the temperature difference between T1S and T1 for turning the additional heating source off (when  $T1 \geq T1S + dT1\_AHS\_OFF$  the additional heating source will turn off)

t\_AHS\_DELAY is the time that the compressor has heat by heat pump only run before starting the additional heating source, it should short than the additional heating source's start time interval.

The operation of the heat pump and the additional heating source described in the picture below:

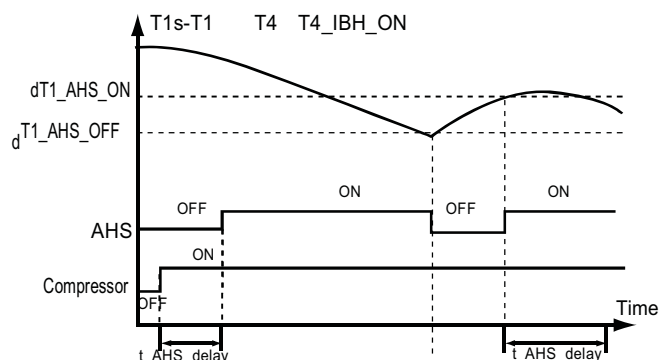



**10.7.9 HOLIDAY AWAY SETTING**

**About HOLIDAY AWAY SETTING**

The HOLIDAY AWAY SETTING is used to set the outlet water temperature when you are in holiday for prevention of freezing.

**How to enter the HOLIDAY AWAY SETTING**

To enter the HOLIDAY AWAY SETTING, go to MENU> FOR SERVICEMAN> HOLIDAY AWAY SETTING. Press OK. The following page will appear:

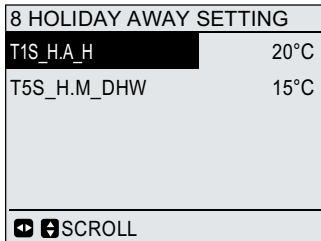

When the cursor is on T1S\_H.A.\_H or T5S\_H.M.\_DHW, Using ◀ ▶ ▼ ▲ to scroll and adjust the parameter, T1S\_H.A.\_H is the target outlet water temperature for space heating when in holiday away mode. T1S\_H.M.\_DHW is the target outlet water temperature for water heating when in holiday away mode.

**10.7.10 SERVICE CALL**

**About SERVICE CALL**

The installers can set the phone number of the local dealer in SERVICE CALL. If unit can't work, you can call this number for help.

**How to set the SERVICE CALL**

To set the SERVICE CALL, go to MENU> FOR SERVICEMAN> SERVICE CALL. Press OK. The following page will appear:

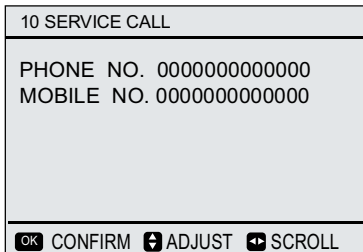

Using ▼ ▲ to scroll and set the phone number, the maximum length of the phone number is 13, if the length of phone number short than 12, please input ■, as described in the picture below:

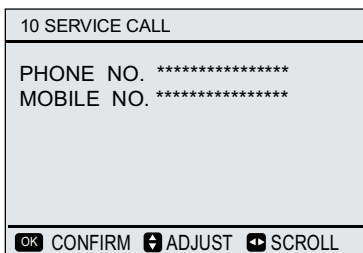

The number displayed on the user interface is the phone number of your local dealer.

**10.7.11 RESTORE FACTORY SETTINGS**

**About RESTORE FACTORY SETTINGS**

The RESTORE FACTORY SETTING is used to restore all the parameters set in the user interface to the factory setting.

**How to set the RESTORE FACTORY SETTINGS**

To restore factory settings, go to MENU> FOR SERVICEMAN> RESTORE FACTORY SETTINGS. Press OK. The following page will appear:

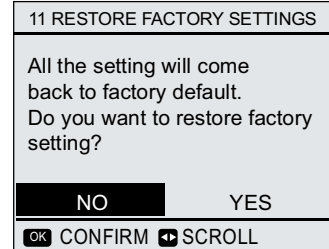

Using ◀ ▶ to scroll the cursor to YES and press OK, the following page will disappear:

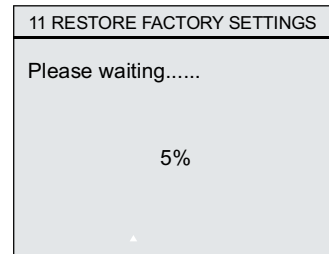

After a few seconds, all the parameters set in the user interface will restore to factory settings

**10.7.12 TEST RUN**

**About TEST RUN**

The TEST RUN is used to check correct operation of the values, air purge, circulted pump running,cooling, heating and domestic water heating

**How to enter the TEST RUN**

To enter the test run, go to MENU> FOR SERVICEMAN> TEST RUN. Press OK. The following page will appear:

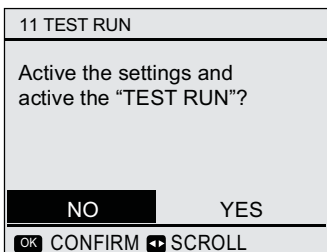

If YES is selected, the following page will appear:

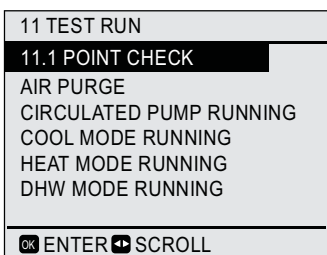

Using ▼ ▲ to scroll to the mode you want to run and press OK, then the unit will run as you selected.

If 12.1 POINT CHECK is selected,the following page will disappear

11.1 POINT CHECK	
3-WAY VALVE	OFF
2-WAY VALVE	OFF
PUMP1	OFF
PUMPO	OFF
PUMPO	OFF
PUMPSOLAR	OFF

SCROLL ON/OFF ON/OFF

11.1 POINT CHECK	
PUMPDHW	OFF
BACKUP HEATER1	OFF
BACKUP HEATER2	OFF
TANK HEATER	OFF

SCROLL ON/OFF ON/OFF

Using ▼ ▲ to scroll to the components you want to check and press ON/OFF, for example, when 3-WAY VALVE is selected and ON/OFF pressed, if the 3-way value is open/close, then the operation of 3-way value is normal, so does other components.

If you select AIR PURGE and OK is pressed, the page will displayed as following:

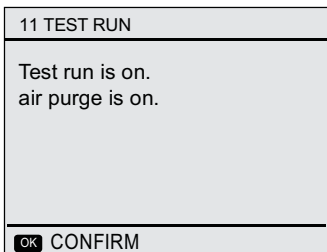

When in air purge mode, the 3-way value will open, the 2-way value will close, 60s later the pump in the unit(PUMPI) will operate for 10min, during which the flow switch will not work. after the pump stoped, the 3-way value will close and the 2-way value will open, 60s later both the PUMPI and PUMPO will operate until the next command received.

When the CIRCULATED PUMP RUNNING is selected, the page will displayed as following:

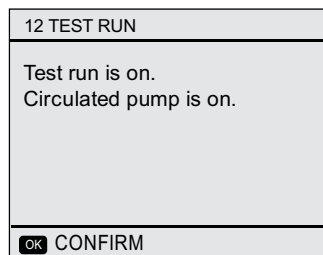

When circulated pump running is turned on, all the running components will stop, 60min later,the 3-way value will open, the 2-way value will close, 60s later PUMPI will operate , 30s later, if the flow switch checked normal flow,the PUMPI will operate for 3min, after the pump stoped, the 3-way value will close and the 2-way value will open, 60s later the both PUMPI and PUMPO will operate, 2min later, the flow switch will check the water flow , if the flow switch close for 15s, the PUMPI and PUMPO will operate until the next command received.

When the COOL MODE RUNNING is selected, the page will displayed as following:

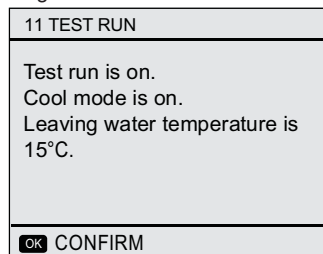

During COOL MODE test running, the default target outlet water temperature is 7°C, the unit will operate until the water temperature drop to a certain value or the next command received.

When the HEAT MODE RUNNING is selected, the page will displayed as following:

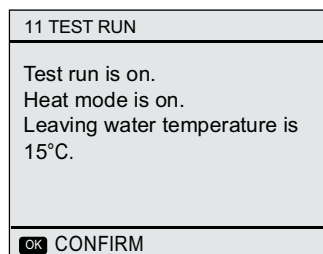

During HEAT MODE test running, the default target outlet water temperature is 35°C, the first backup heater will turn on after the compressor runned for 10min, 60s later the second backup heater will turn on. After the two backup heater runned for 3min, both backup heater will turn off,the heat pump will operate until the water temperature increase to a certain value or the next command received.

When the DHW MODE RUNNING is selected, the page will displayed as following:

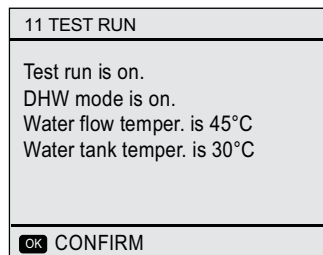

During DHW MODE test running, the default target temperature of the domestic water is 55°C, the booster heater will turn on after the compressor runned for 10min, the booster heater will turn off 3min later, the heat pump will operate until the water temperature increase to a certain value or the next command received.

During test run, all the buttons except OK is invalid. If you want to turn off the test run, please press OK, for example, when the unit is in air purge mode, after you press OK, the page will displayed as following:

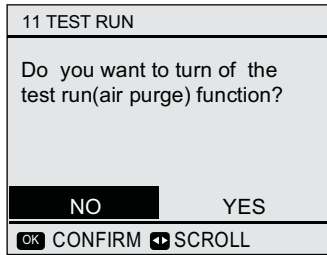

Using ◀ ▶ to scroll the cursor to YES and press OK, the test run will turn off.

The number displayed on the page is the time that the air purge has running. During air purge, all the buttons except OK is invalid. If you want to turn off the air purge, please press OK, then the following page will appear:

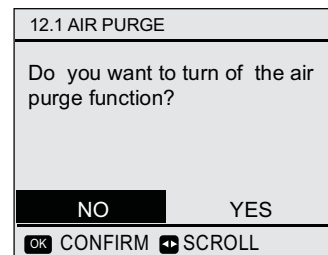

Use ◀ ▶ to scroll and use OK to confirm.

If PREHEATING FOR FLOOR is selected, after press OK, the page will displayed as following:

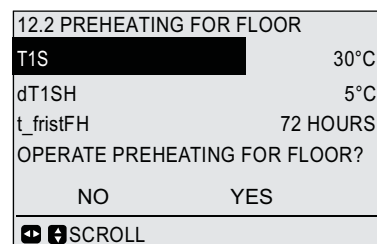

**10.7.13 SPECIAL FUNCTION**

**About SPECIAL FUNCTION**

The SPECIAL FUNCTION contains AIR PURGE, PREHEATING FOR FLOOR, FLOOR DRYING UP. It's used in some special conditions, for example: the initial start of the unit, initial running of floor heating.

**How to enter the SPECIAL FUNCTION**

Go to MENU> FOR SERVICEMAN> SPECIAL FUNCTION.

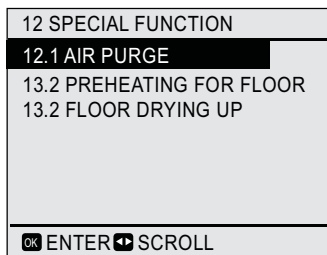

Use ▼ ▲ to scroll and use OK to enter. During first operation of the unit, air may remained in the system which can case malfunction during operation, so it is necessary to run air purge function to release the air (make sure the air purge value opened).

Go to FOR SERVICEMAN > 12 SPECIAL FUNCTION>12.1AIR PURGE

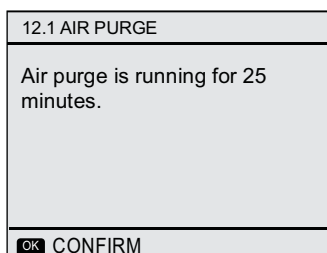

During air purge, the 3-way value will open, the 2-way value will close, 60seconds later the pump in the unit (PUMPI) will operate for 10min, during which the flow switch will not work. after the pump stoped, the 3-way value will close and the 2-way value will open, 60s later the both the PUMPI and PUMPO will operate until the stopping command recived.

When the cursor is on T1S, dT1SH or t\_fristFH, Using ◀, ▶, ▼, ▲ to scroll and adjust the parameter. T1S is the target outlet water temperature in preheating for floor mode, the T1S set here should equal to the target outlet water temperature set in the main page. dT1SH is the temperature difference for stopping the unit. (When  $T1 \geq T1S + dT1S$  the heat pump will turn off) t\_fristFH is the time last for preheating floor. The operation of the unit during preheating for floor described in the picture below:

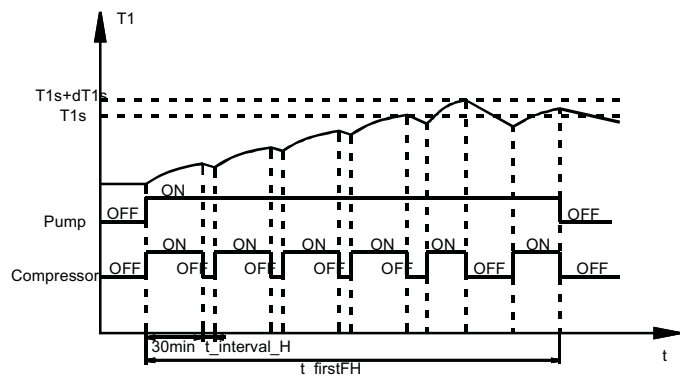

When the cursor is on OPERATE PREHEATING FOR FLOOR, Using ◀ ▶ to scroll to YES and press OK, the page will be displayed as following:

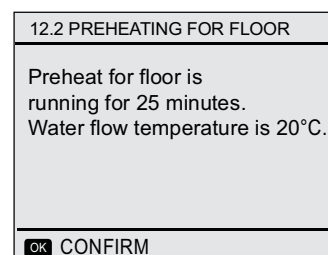

During preheating for floor, all the buttons except OK is invalid. If you want to turn off the preheating for floor, please press OK, then the page will displayed as following:

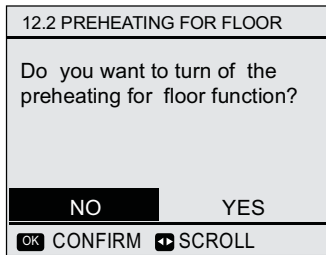

Using ◀ ▶ to scroll the cursor to YES and press OK, the preheating for floor will turn off.

Before floor heating, if large amount of water remain in the floor, the floor may be deformed or even rupture during floor heating operation, in order to protect the floor, floor drying is necessary, during which the temperature of the floor should be increased gradually. If FLOOR DRYING UP is selected, after press OK ,the page will displayed as following:

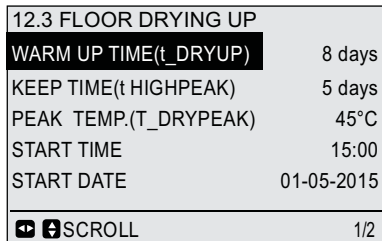

When the cursor is on **WARM UP TIME(t\_DRYUP)**, **KEEP TIME (t\_HIGHPEAK)**, **TEMP. DOWN TIME(t\_DRYD)**, **PEAK TEMP. (T\_DRYPEAK)**, **START TIME** or **START DATA**, Using ◀ ▶ ▼ ▲ to scroll and adjust the parameter.  
 t\_DRYUP is the day for warming up;  
 t\_HIGHPEAK is the day that high temperature last;  
 t\_DRYD is the day for dropping temperature  
 T\_DRYPEAK is the target peak temperature of water flow during floor drying up.

The target outlet water temperature during floor drying up described in the picture below:

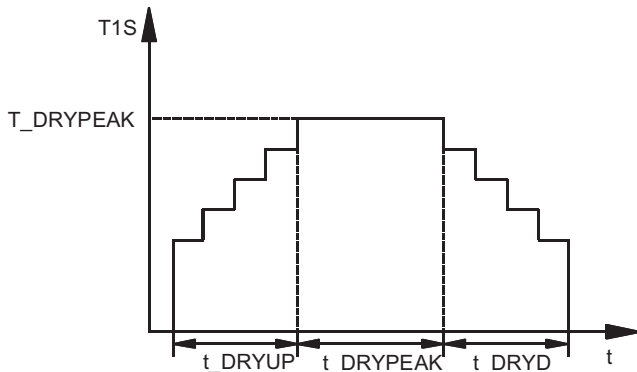

When the cursor is on OPERATE FLOOR DRYING UP?, Using ◀ ▶ to scroll to YES and press OK, the page will be displayed as following:

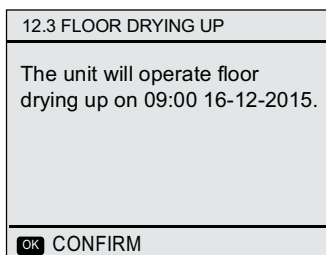

During floor drying up, all the buttons except OK is invalid. When the heat pump malfunction, the floor drying mode will turn off when the backup heater and additional heating source is unavailable. If you want to turn off the floor drying up, please press OK, then the page will displayed as following:

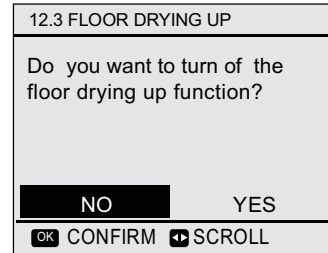

Using ◀ ▶ to scroll the cursor to YES and press OK, the floor drying up will turn off.

**10.7.14 AUTO RESTART**

**About AUTO RESTART**

The AUTO RESTART function is used to select whether the unit reapplies the user interface settings at the time of the power supply returns after power supply failure.

**How to set the AUTO RESTART**

Go to MENU> FOR SERVICEMAN> AUTO RESTART.

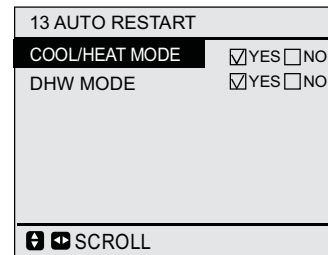

Use ▼ ▲ ◀ ▶ to scroll and use OK to select YES or NON to enable or disable the auto restart function. If the auto restart function is enabled, when power returns after a power supply failure, the AUTO RESTART function reapplies the user interface settings at the time of the power supply failure. If this function is disabled, when power returns after a power supply failure, the unit won't auto restart.

**10.7.15 Nouns illustration**

The nouns related to this unit illustrated in the table bellow

Parameter	Illustration
T1	Outlet water temperature of backup heater
T1B	Outlet water temperature of additional heating source
T1S	Target outlet water temperature
T2	Temperature of refrigerant at outlet /inlet of plate heat exchanger when in heat mode/cool mode
T2B	Temperature of refrigerant at inlet /outlet of plate heat exchanger when in heat mode/cool mode
T3	Temperature of tube at outlet/inlet of condenser when in cool/heat mode
T4	Ambient temperature
T5	Temperature of domestic hot water
Th	Suction temperature
Tp	Discharge temperature
Tw_in	Inlet water temperature of plate heat exchanger
Tw_out	Outlet water temperature of plate heat exchanger
AHS	Additional heating source
IBH1	Thefirst backup heater
IBH 2	The second backup heater
TBH	Backup heater in the domestic hot water tank
Pe	Evaporate/condense pressure in cool/heat mode

## 11 TEST RUN AND FINAL CHECK

The installer is obliged to verify correct operation of unit after installation.

### 11.1 Final check

Before switching on the unit, read following recommendations:

- When the complete installation and all necessary settings have been carried out, close all front panels of the unit and refit the unit cover.
- The service panel of the switch box may only be opened by a licensed electrician for maintenance purposes.



### NOTE

That during the first running period of the unit, required power input may be higher than stated on the nameplate of the unit. This phenomenon originates from the compressor that needs elapse of a 50 hours run in period before reaching smooth operation and stable power consumption.

### 11.2 Test run operation (manual)

If required, the installer can perform a manual test run operation at any time to check correct operation of air purge, heating, cooling and domestic water heating, refer to **10.7 Field settings/test run**.

## 12 MAINTENANCE AND SERVICE

In order to ensure optimal availability of the unit, a number of checks and inspections on the unit and the field wiring have to be carried out at regular intervals.

This maintenance needs to be carried out by your local technician. In order to ensure optimal availability of the unit, a number of checks and inspections on the unit and the field wiring have to be carried out at regular intervals.

This maintenance has to be carried out by your local Midea technician.



### DANGER

#### ELECTRIC SHOCK

- Before carrying out any maintenance or repair activity, always switch off the circuit breaker on the supply panel, remove the fuses (or switch off the circuit breakers) or open protection devices of the unit.
- Make sure that before starting any maintenance or repair activity that the power supply to the outdoor unit is switched off.
- Do not touch live parts for 10 minutes after the power supply is turned off because of high voltage risk.
- The heater for the compressor may operate even in stop mode.
- Please note that some sections of the electric component box are hot.
- Make sure you do not touch a conductive section.
- Do not rinse the unit. This may cause electric shocks or fire.
- When service panels are removed, live parts can be easily touched by accident.  
Never leave the unit unattended during installation or servicing when service panel is removed.

The described checks must be executed at least once a year by qualified personnel.

1. Water pressure
    - Check if the water pressure is above 1 bar. If necessary add water.
  2. Water filter
    - Clean the water filter.
  3. Water pressure relief valve
    - Check for correct operation of the pressure relief valve by turning the black knob on the valve counter-clockwise:
      - If you do not hear a clacking sound, contact your local dealer.
      - In case the water keeps running out of the unit, close both the water inlet and outlet shut-off valves first and then contact your local dealer.
  4. Pressure relief valve hose
    - Check that the pressure relief valve hose is positioned appropriately to drain the water.
  5. Backup heater vessel insulation cover
    - Check that the backup heater insulation cover is fastened tightly around the backup heater vessel.
  6. Domestic hot water tank pressure relief valve (field supply)
    - Applies only to installations with a domestic hot water tank. Check for correct operation of the pressure relief valve on the domestic hot water tank.
  7. Domestic hot water tank booster heater
    - Applies only to installations with a domestic hot water tank. It is advisable to remove lime buildup on the booster heater to extend its life span, especially in regions with hard water. To do so, drain the domestic hot water tank, remove the booster heater from the domestic hot water tank and immerse in a bucket (or similar) with lime-removing product for 24 hours.
  8. Unit switch box
    - Carry out a thorough visual inspection of the switch box and look for obvious defects such as loose connections or defective wiring.
    - Check for correct operation of contactors with an ohm meter. All contacts of these contactors must be in open position.
  9. Use of glycol
    - (Refer to 9.3 Water pipework Caution: "Use of glycol" ) Document the glycol concentration and the pH-value in the system at least once a year.
      - A pH-value below 8.0 indicates that a significant portion of the inhibitor has been depleted and that more inhibitor needs to be added.
      - When the pH-value is below 7.0 then oxidation of the glycol occurred, the system should be drained and flushed thoroughly before severe damage occurs.
- Make sure that the disposal of the glycol solution is done in accordance with relevant local laws and regulations.

## 13 TROUBLE SHOOTING

This section provides useful information for diagnosing and correcting certain troubles which may occur in the unit. This troubleshooting and related corrective actions may only be carried out by your local technician.

### 13.1 General guidelines

Before starting the troubleshooting procedure, carry out a thorough visual inspection of the unit and look for obvious defects such as loose connections or defective wiring.





**WARNING**

When carrying out an inspection on the switch box of the unit, always make sure that the main switch of the unit is switched off.

When a safety device was activated, stop the unit and find out why the safety device was activated before resetting it. Under no circumstances can safety devices be bridged or changed to a value other than the factory setting. If the cause of the problem cannot be found, call your local dealer.

If the pressure relief valve is not working correctly and is to be replaced, always reconnect the flexible hose attached to the pressure relief valve to avoid water dripping out of the unit!



**NOTE**

For problems related to the optional solar kit for domestic water heating, refer to the troubleshooting in the Installation & Owner's manual for that kit.

**13.2 General symptoms**

**Symptom 1: The unit is turned on but the unit is not heating or cooling as expected**

POSSIBLE CAUSES	CORRECTIVE ACTION
The temperature setting is not correct.	Check the controller set point.T4HMAX, T4HMIN in heat mode.T4CMAX,T4CMIN in cool mode.T4DHWMAX,T4DHWMIN in DHW mode.
The water flow is too low.	<ul style="list-style-type: none"> <li>• Check that all shut off valves of the water circuit are completely open.</li> <li>• Check if the water filter needs cleaning.</li> <li>• Make sure there is no air in the system (purge air).</li> <li>• Check on the manometer that there is sufficient water pressure. The water pressure must be &gt;1 bar (water is cold).</li> <li>• Make sure that the expansion vessel is not broken.</li> <li>• Check that the resistance in the water circuit is not too high for the pump</li> </ul>
The water volume in the installation is too low.	Make sure that the water volume in the installation is above the minimum required value (refer to "9.3 water pipework/Checking the water volume and expansion vessel pre-pressure").

**Symptom 2: The unit is turned on but the compressor is not starting (space heating or domestic water heating)**

POSSIBLE CAUSES	CORRECTIVE ACTION
The unit must start up out of its operation range (the water temperature is too low).	<p>In case of low water temperature, the system utilizes the backup heater to reach the minimum water temperature first (12°C).</p> <ul style="list-style-type: none"> <li>• Check that the backup heater power supply is correct.</li> <li>• Check that the backup heater thermal fuse is closed.</li> <li>• Check that the backup heater thermal protector is not activated.</li> <li>• Check that the backup heater contactors are not broken.</li> </ul>

**Symptom 3: Pump is making noise (cavitation)**

POSSIBLE CAUSES	CORRECTIVE ACTION
There is air in the system.	Purge air.
Water pressure at pump inlet is too low.	<ul style="list-style-type: none"> <li>• Check on the manometer that there is sufficient water pressure. The water pressure must be &gt; 1 bar (water is cold).</li> <li>• Check that the manometer is not broken.</li> <li>• Check that the expansion vessel is not broken.</li> <li>• Check that the setting of the pre- pressure of the expansion vessel is correct (refer to "9.3 water pipework/Checking the water volume and expansion vessel pre-pressure").</li> </ul>

**Symptom 4: The water pressure relief valve opens**

POSSIBLE CAUSES	CORRECTIVE ACTION
The expansion vessel is broken.	Replace the expansion vessel.
The filling water pressure in the installation is higher than 0.3MPa.	Make sure that the filling water pressure in the installation is about 0.15~0.20MPa (refer to "9.3 water pipework/Checking the water volume and expansion vessel pre-pressure").

**Symptom 5: The water pressure relief valve leaks**

POSSIBLE CAUSES	CORRECTIVE ACTION
Dirt is blocking the water pressure relief valve outlet.	<p>Check for correct operation of the pressure relief valve by turning the red knob on the valve counter clockwise:</p> <ul style="list-style-type: none"> <li>• If you do not hear a clacking sound, contact your local dealer.</li> <li>• In case the water keeps running out of the unit, close both the water inlet and outlet shut-off valves first and then contact your local dealer.</li> </ul>

**Symptom 6: Space heating capacity shortage at low outdoor temperatures**

POSSIBLE CAUSES	CORRECTIVE ACTION
Backup heater operation is not activated.	<p>Check that the "OTHER HEATING SOURCE/ BACKUP HEATER" is enabled, see "10.7 Field settings"</p> <p>Check whether or not the thermal protector of the backup heater has been activated (refer to 9.2.3 Switch box main components (door 2), "Backup heater thermal protector" for location of the reset button).</p> <p>Check if booster heater is running, the backup heater and booster heater can't operate simultaneously.</p>
Too much heat pump capacity is used for heating domestic hot water (applies only to installations with a domestic hot water tank).	<p>Check that the 't_DHWHP_MAX' and 't_DHWHP_RESTRICT' are configured appropriately:</p> <ul style="list-style-type: none"> <li>• Make sure that the 'DHW PRIORITY' in the user interface is disabled.</li> <li>• Enable the "T4_TBH_ON" in the user interface/FOR SERVICEMAN to activate the booster heater for domestic water heating</li> </ul>

### 14 PARAMETERS CHECK IN THE UNIT

To check the parameters of hydraulic box, open door 2 and you'll see the PCB like following, the digital display will show the temperature of outlet water in normal condition ('0' will display if the unit is off or error code will display if error occurs). Long press the check button and the digital display will show the operating mode. Then press the check button in sequence. The digital display will show the value, the implication of the value illustrated in the diagram below:

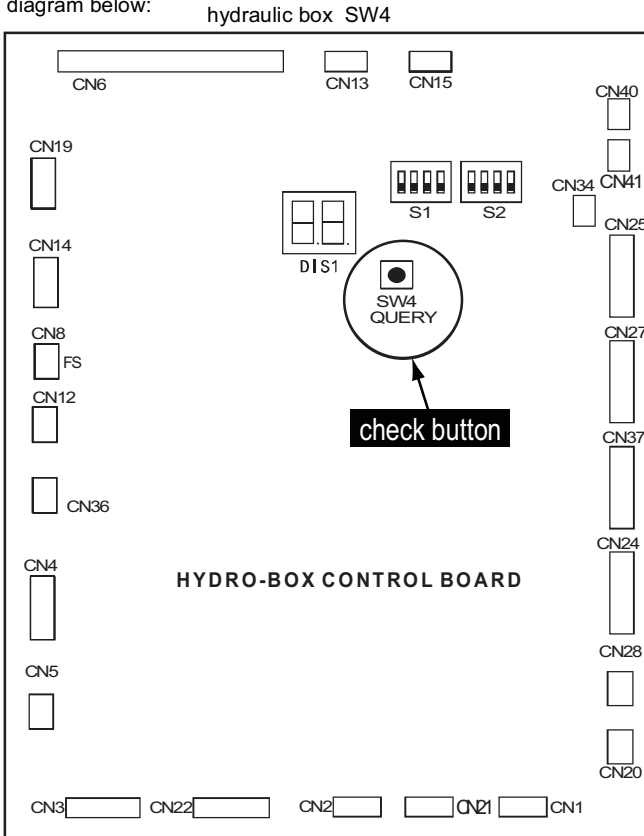

Number	Implication
0	Temperature of outlet water when unit is on, when the unit is off, '0' will display
1	Operation mode(0—OFF 2—COOL 3—HEAT 5—Water heating)
2	Capacity requirement before correction
3	Capacity requirement after correction
4	Outlet water temperature of backup heater
5	Outlet water temperature of additional heating source
6	Target outlet water temperature calculated from climate-related curves
7	Room temperature
8	Temperature of domestic hot water
9	Temperature of refrigerant at outlet /inlet of plate heat exchanger when in heat mode/cool mode
10	Temperature of refrigerant at inlet /outlet of plate heat exchanger when in heat mode/cool mode
11	Temperature of water at outlet of plate heat exchanger
12	Temperature of water at inlet of plate heat exchanger
13	Ambient temperature
14	Current of backup heater 1
15	Current of backup heater 2
16	Error/protection code for the last time, '—' will display if no error/protection occur
17	Error/protection code for the second last time, '—' will display if no error/protection occur
18	Error/protection code for the third last time, '—' will display if no error/protection occur
19	Version of software (hydraulic module)

To check the parameters on the refrigerant side, open door 1 and you'll see the PCB like the following (different for 1-phase and 3-phase unit): the digital display will show the present compressor frequency ('0' will display if the unit is off or error code will display if error occurs). Long press the check button and the digital display will show the operating mode, and then press the check button in sequence. The digital display will show the value, the implication of the value is shown in the diagram below:

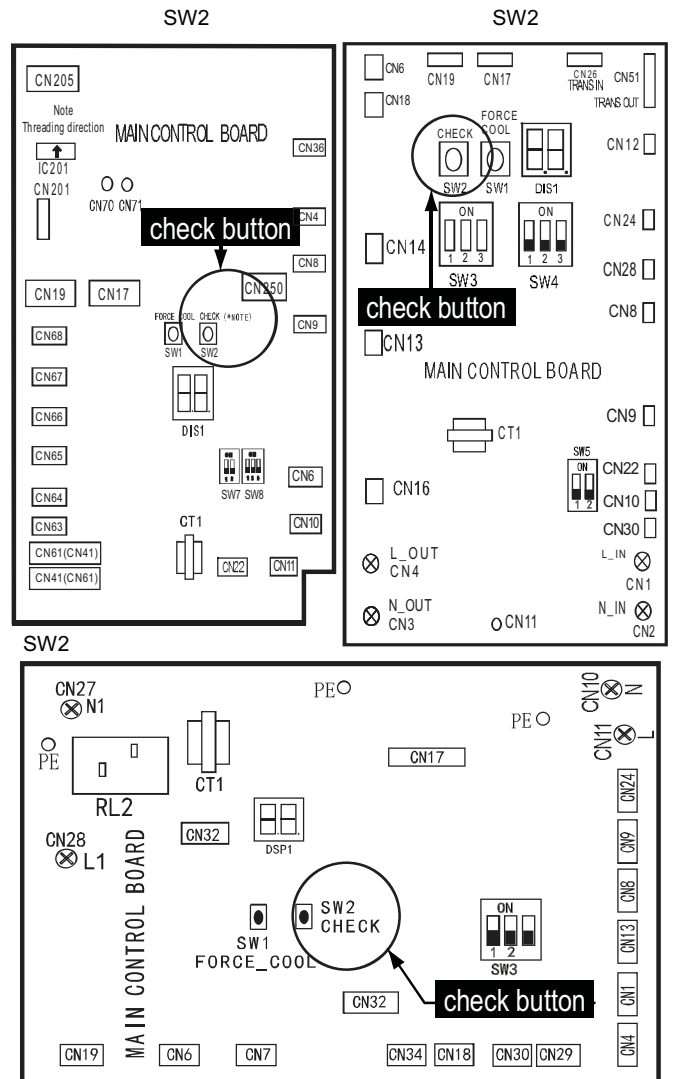

Number	Implication
0	Frequency of compressor at present
1	Operation mode (0—Standby 2—COOL 3—HEAT 5—refrigerant recovery)
2	Fan speed
3	Frequency from hydraulic module
4	Frequency after restriction by the outdoor unit
5	Temperature of tube at outlet/inlet of condenser when in cool/heat mode
6	Ambient temperature
7	Discharge temperature
8	Suction temperature (when the temperature lower than -9 °C. Will stand for negative sign)
9	The opening of EEV (the value display multiply 8 will be the actual opening)
10	Actual current
11	Actual voltage
12	Pressure of refrigerant (evaporate/condense pressure when in cool /heat mode )
13	Version of software (outdoor unit)
14	Error/protection code for the last time, 'nn' will display if no error/protection occurs
15	—

**14.4 Error codes**

When a safety device is activated, an error code will be displayed on the user interface.

A list of all errors and corrective actions can be found in the table below.

Reset the safety by turning the unit OFF and back ON.

In case this procedure for resetting the safety is not successful, contact your local dealer.

Error code	Malfunction or protection	Failure cause and Corrective action
E0	Flow switch error (E8 displayed 3 times)	1.The wire circuit is short connected or open. Reconnect the wire correctly. 2.Water flow rate is too low. 3. Water flow switch is failed, switch is open or close continuously, change the water flow switch.
E1	Phase sequence fault(only for three-phase unit)	1.Check the power supply cables should be connected stable, to avoid phase loss. 2.Check the power supply cables sequence, change any two cables sequence of the three power supply cables.
E2	Communication error between wired controller and unit	1.wire doesn't connect between wired controller and unit. connect the wire. 2.Communication wire sequence is not right. Reconnect the wire in the right sequence. 3. Whether there is a high magnetic field or high power interfere, such as lifts, large power transformers, etc..  To add a barrier to protect the unit or to move the unit to the other place.
E3	The backup heater exchanger outlet water temperature sensor T1 error.	1. The T1 sensor connector is loosen. Reconnect it. 2.The T1 sensor connector is wet or there is water in. remove the water, make the connector dry. Add waterproof adhesive. 3.The T1 sensor failure, change a new sensor.

Error code	Malfunction or protection	Failure cause and Corrective action
E4	The domestic hot water temperature sensor T5 error.	1.The T5 sensor connector is loosen Reconnect it. 2.The T5 sensor connector is wet or there is water in. remove the water, make the connector dry. Add waterproof adhesive 3.The T5 sensor failure, change a new sensor.
E5	The condenser outlet refrigerant temperature sensor (T3)error.	1. The T3 sensor connector is loosen Reconnect it. 2.The T3 sensor connector is wet or there is water in. remove the water, make the connector dry. Add waterproof adhesive 3. The T3 sensor failure, change a new sensor.
E6	The ambient temperature sensor (T4) error.	1. The T4 sensor connector is loosen Reconnect it. 2.The T4 sensor connector is wet or there is water in. remove the water, make the connector dry. Add waterproof adhesive 3. The T4 sensor failure, change a new sensor.
E8	Water flow failure	Check that all shut off valves of the water circuit are completely open. 1 Check if the water filter needs cleaning. 2 Refer to "9.4 Charging water" 3 Make sure there is no air in the system (purge air). 4 Check on the manometer that there is sufficient water pressure. The water pressure must be >1 bar. 5 Check that the pump speed setting is on he highest speed. 6 Make sure that the expansion vessel is not broken. 7 Check that the resistance in the water circuit is not too high for the pump (refer to "Setting the pump speed" ). 8 If this error occurs at defrost operation (during space heating or domestic water heating), make sure that the backup heater power supply is wired correctly and that fuses are not blown. 9 Check that the pump fuse and PCB fuse are not blown.

Error code	Malfunction or protection	Failure cause and Corrective action
E9	Suction pipe sensor Th error	1. The Th sensor connector is loosen Re connect it. 2.The Th sensor connector is wet or there is water in. remove the water, make the connector dry. Add waterproof adhesive 3. The Th sensor failure, change a new sensor.
H0	Communication error between outdoor Unit and indoor unit	1.wire doesn't connect between indoor unit and outdoor unit. connect the wire. 2.Communication wire sequence is not right. Reconnect the wire in the right sequence. 3. Whether there is a high magnetic field or high power interfere, such as lifts, large power transformers etc To add a barrier to protect the unit or to move the unit to the other place.
H1	Communication error between outdoor unit and IR341	1. Whether there is power connected to the PCB and driven board. Check the PCB indicator light is on or off. If Light is off, reconnect the power supply wire. 2.if light is on, check the wire connection between the main PCB and driven PCB, if the wire loosen or broken, reconnect the wire or change a new wire. 3. Replace a new main PCB and driven board in turn.
H2	The plate heat exchanger refrigerant inlet(liquid pipe) temperature sensor(T2) error.	1.The T2 sensor connector is loosen Re connect it. 2.The T2 sensor connector is wet or there is water in. remove the water, make the connector dry. Add waterproof adhesive 3. The T2 sensor failure, change a new sensor.
H3	The plate heat exchanger refrigerant outlet(gas pipe) temperature sensor (T2B ) error.	1. The T2B sensor connector is loosen Re connect it. 2.The T2B sensor connector is wet or there is water in. remove the water, make the connector dry. Add waterproof adhesive 3. The T2B sensor failure, change a new sensor.
H4	Three times P6 protect	Same to P6

Error code	Malfunction or protection	Failure cause and Corrective action
H5	The indoor temperature sensor(Ta) error	1. The Ta sensor is in the interface; 2. The Ta sensor failure change a new sensor or change a new interface.
H6	The DC fan failure	1. Strong wind or typhoon below toward to the fan, to make the fan running in the opposite direction. Change the unit direction or make shelter to avoid typhoon below to the fan. 2.fan motor is broken, change a new fan motor.
H7	Main circuit voltage failure	1. Whether the power supply input is in the available range. 2. Power off and power on for several times rapidly in short time. Remain the unit power off for more than 3 minutes than power on. 3. the circuit defect part of Main control board is defective. Replace a new Main PCB.
H8	Pressure sensor failure	1. Pressure sensor connector is loosen, reconnect it. 2. Pressure sensor failure. change a new sensor.
H9	The system outlet water temperature sensor T1B failure.	1. The T1B sensor connector is loosen. Reconnect it. 2.The T1B sensor connector is wet or there is water in. remove the water, make the connector dry. add waterproof adhesive 3. The T1B sensor failure, change a new sensor.
HA	The plate heat exchanger water outlet temperature sensor (Twout) error.	1. The Twout sensor connector is loosen. Reconnect it. 2.The Twout sensor connector is wet or there is water in. remove the water, make the connector dry. add waterproof adhesive 3. The Twout sensor failure, change a new sensor.
HE	The condenser refrigerant outlet temperature is too high in heating mode for more than 10 minutes.	The outside ambient temperature is too high(higher than 30 , the unit still operate heat mode. close the heat mode when the ambient temperature is higher than 30

Error code	Malfunction or protection	Failure cause and Corrective action
HF	The outdoor unit EEPROM failure	1. The EEPROM parameter is error, rewrite the EEPROM data. 2. EEPROM chip part is broken, change a new EEPROM chip part. 3. Main PCB is broken, change a new PCB.
HH	H6 displayed 10 times in 2 hours	Refer to H6
P0	Low pressure protection	1. System is lack of refrigerant volume. Charge the refrigerant in right volume. 2. When at heating mode or heat water mode, Heat exchanger is dirty or something is block on the surface. Clean the heat exchanger or remove the obstruction. 3. The water flow is low in cooling mode. 4. Electrical expansion valve locked or wiring connector is loosen. Tap-tap the valve body and plug in/ plug off the connector for several times to make sure the valve is working correctly. And install the wiring in the right location
P1	High pressure protection	Heating mode DHW mode: 1. The water flow is low; water temp is high, whether there is air in the water system. Release the air. 2. Water pressure is lower than 0.1Mpa, charge the water to let the pressure in the range of 0.15~0.2Mpa. 3. Over charge the refrigerant volume. Recharge the refrigerant in right volume. 4. Electrical expansion valve locked or winding connector is loosen. Tap-tap the valve body and plug in/ plug off the connector for several times to make sure the valve is working correctly. And install the winding in the right location DHW mode: Water tank heat exchanger is smaller than the required 1.7m <sup>2</sup> (10-16kW unit) or 1.4m <sup>2</sup> (5-7kW unit) Cooling mode: 1. Heat exchanger cover is not removed. Remove it. 2. Heat exchanger is dirty or something is block on the surface. Clean the heat exchanger or remove the obstruction.

Error code	Malfunction or protection	Failure cause and Corrective action
P3	Compressor overcurrent protection.	1. The same reason to P1. 2. Power supply voltage of the unit is low, increase the power voltage to the required range.
P4	High discharge temperature protection.	1. The same reason to P1. 2. System is lack of refrigerant volume. Charge the refrigerant in right volume. 3. Two temp sensor is loosen Reconnect it.. 4. T1 temp sensor is loosen Reconnect it. 5. T5 temp sensor is loosen Reconnect it.
P5	High Temperature difference protection between water inlet and water outlet of the plate heat exchanger.	1. Check that all shut off valves of the water circuit are completely open • Check if the water filter needs cleaning. • Refer to "9.4 Charging water" • Make sure there is no air in the system (purge air).  • Check on the manometer that there is sufficient water pressure. The water pressure must be >1 bar (water is cold). • Check that the pump speed setting is on the highest speed. • Make sure that the expansion vessel is not broken. • Check that the resistance in the water circuit is not too high for the pump (refer to "10.6 Setting the pump speed").
P6	Module protection	1. Power supply voltage of the unit is low, increase the power voltage to the required range. 2. The space between the units is too narrow for heat exchange. Increase the space between the units. 3. Heat exchanger is dirty or something is block on the surface. Clean the heat exchanger or remove the obstruction. 4. Fan is not running. Fan motor or fan is broken, Change a new fan or fan motor.



Error code	Malfunction or protection	Failure cause and Corrective action
P6	Module protection	<p>5. Over charge the refrigerant volume. Recharge the refrigerant in right volume.</p> <p>6. Water flow rate is low, there is air in system, or pump head is not enough. Release the air and reselect the pump.</p> <p>7. Water outlet temp sensor is loosen or broken, reconnect it or change a new one.</p> <p>8. Water tank heat exchanger is smaller than the required 1.7m<sup>2</sup>.(10-16kW unit)or 1.4m<sup>2</sup>(5-7kW unit)</p> <p>9. Module wires or screws are loosen. Reconnect wires and screws. The Thermal Conductive Adhesive is dry or drop. Add some thermal conductive adhesive.</p> <p>10. The wire connection is loosen or drop. Reconnect the wire.</p> <p>11. Drive board is defective, replace a new one.</p> <p>12. if already confirm the control system has no problem, then compressor is defective, replace a new compressor.</p>
Pb	Anti-freeze mode protection.	Unit will return to the normal operation automatically.
Pd	High temperature protection of refrigerant outlet temp of condenser.	<p>1. Heat exchanger cover is not removed. Remove it.</p> <p>2. Heat exchanger is dirty or something is block on the surface. Clean the heat exchanger or remove the obstruction.</p> <p>3. There is no enough space around the unit for heat exchanging.</p> <p>4. fan motor is broken, replace a new one.</p>
PP	Water inlet temperature is higher than water outlet in heating mode	<p>1. The water inlet/outlet sensor wire connector is loosen Reconnect it.</p> <p>2. The water inlet/outlet Tw_in /Tw_out sensor is broken, Change a new sensor.</p> <p>3. Four-way valve is blocked. Restart the unit again to let the valve change the direction. Four-way valve is broken, change a new valve.</p>

H0	communication between outdoor unit and hydraulic box failure	Check the cable connection between outdoor unit and hydraulic box
HP	Low pressure protection (P<0.6) happened 3 times in an hour.	Contact your local dealer.

## 15 TECHNICAL SPECIFICATIONS

### 15.1 General

	1-phase	3-phase	1-phase
	10\12\14\16	12\14\16	5/7
Nominal capacity	Refer to the Technical Data		
Dimensions H x W x D	1414×1404×405mm	1414×1404×405mm	945×1210×402mm
Weight			
Net weight	162kg	177kg	99kg
Gross weight	183kg	198kg	117kg
Connections			
water inlet/outlet	G5/4"BSP	G5/4"BSP	G1"BSP
Water drain	hose nipple		
Expansion vessel			
volume	5L	5L	2L
Maximum working pressure (MWP)	8 bar	8 bar	8 bar
Pump			
Type	water cooled	water cooled	water cooled
No. of speed	3	3	3
Internal water volume	5.5L	5.5L	2.0L
Pressure relief valve water circuit	3 bar	3 bar	3 bar
Operation range - water side			
heating	+12~+60°C	+12~+60°C	+12~+60°C
cooling	+5~+25°C	+5~+25°C	+5~+25°C
Operation range - air side			
• heating	-20~+35°C	-20~+35°C	-20~+35°C
• cooling	-5~+46°C	-5~+46°C	-5~+46°C
• domestic hot water by heat pump	-20~43°C	-20~43°C	-20~43°C

### 15.2 Electrical specifications

	1-phase 5\7\10\12\14\16	3-phase 12\14\16
<b>Standard unit (power supply via unit)</b>		
• power supply	220-240V~ 50Hz	380-415V 3N~ 50Hz
• nominal running current		
<b>Standard unit (power supply via unit)</b>		
• power supply	See "9.6.5 Connection of the backup heater power supply".	
• nominal running current	See "9.6.5 Connection of the backup heater power supply".	

ANNEX 1: WIRING DIAGRAM
1 phase (5 to 7kW)

MAIN BOARD 1 table with columns: Sequence, Content, S1, S2, S3, S4, S5, S6, S7, S8, S9, S10, S11, S12, S13, S14, S15

MAIN BOARD 2 table with columns: Sequence, Content, S1, S2, S3, S4, S5, S6, S7, S8, S9, S10, S11, S12, S13, S14, S15

PROPERTY VALUES table with columns: Property, Value

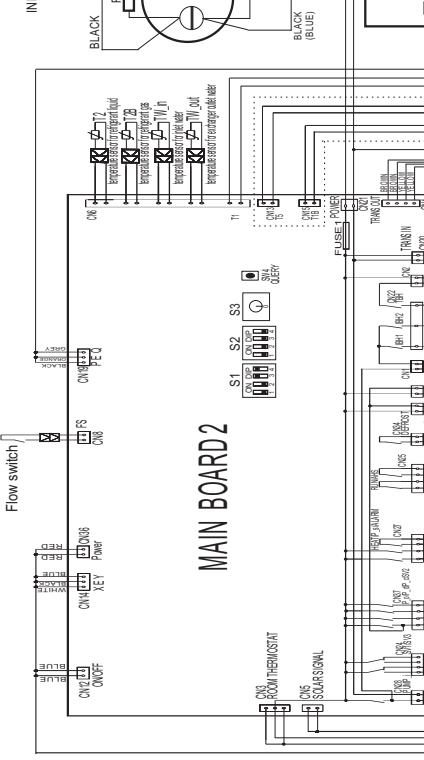
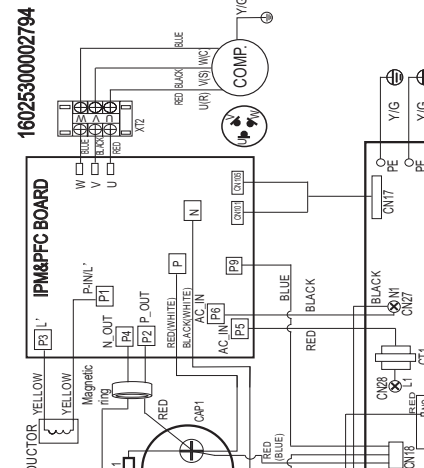

PROPERTY VALUES table with columns: Property, Value

PROPERTY VALUES table with columns: Property, Value

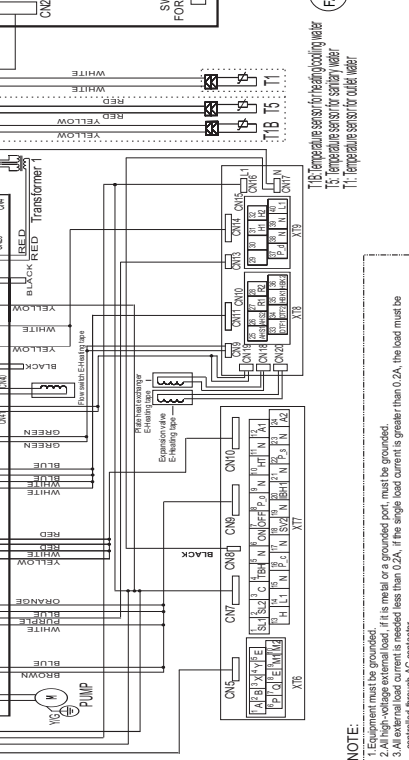
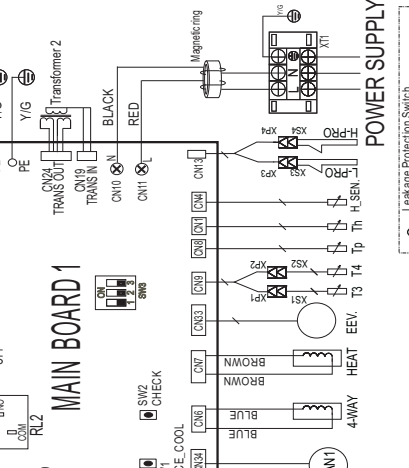

Display table with columns: Display, Description

Display table with columns: Display, Description

Display table with columns: Display, Description

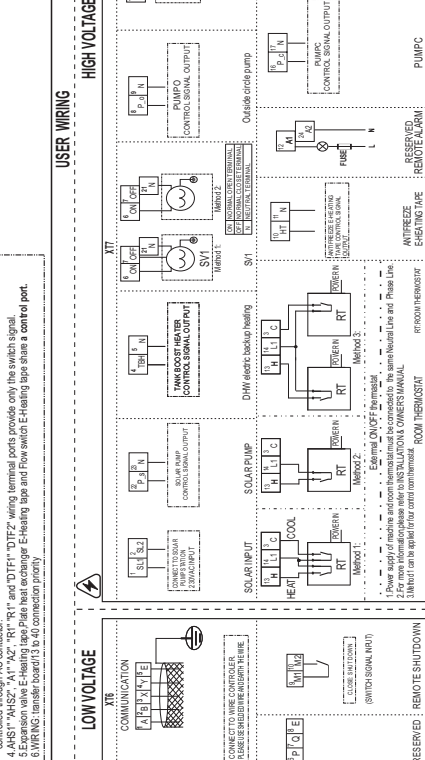

NOTE: 1. Equipment must be grounded. 2. All high-voltage external load, if it is metal or a grounded port, must be grounded. 3. An external load current is needed less than 0.2A, if the single load current is greater than 0.2A, the load must be grounded. 4. MS1, MS2, MS3, MS4, MS5, MS6, MS7, MS8, MS9, MS10, MS11, MS12, MS13, MS14, MS15, MS16, MS17, MS18, MS19, MS20, MS21, MS22, MS23, MS24, MS25, MS26, MS27, MS28, MS29, MS30, MS31, MS32, MS33, MS34, MS35, MS36, MS37, MS38, MS39, MS40, MS41, MS42, MS43, MS44, MS45, MS46, MS47, MS48, MS49, MS50, MS51, MS52, MS53, MS54, MS55, MS56, MS57, MS58, MS59, MS60, MS61, MS62, MS63, MS64, MS65, MS66, MS67, MS68, MS69, MS70, MS71, MS72, MS73, MS74, MS75, MS76, MS77, MS78, MS79, MS80, MS81, MS82, MS83, MS84, MS85, MS86, MS87, MS88, MS89, MS90, MS91, MS92, MS93, MS94, MS95, MS96, MS97, MS98, MS99, MS100, MS101, MS102, MS103, MS104, MS105, MS106, MS107, MS108, MS109, MS110, MS111, MS112, MS113, MS114, MS115, MS116, MS117, MS118, MS119, MS120, MS121, MS122, MS123, MS124, MS125, MS126, MS127, MS128, MS129, MS130, MS131, MS132, MS133, MS134, MS135, MS136, MS137, MS138, MS139, MS140, MS141, MS142, MS143, MS144, MS145, MS146, MS147, MS148, MS149, MS150, MS151, MS152, MS153, MS154, MS155, MS156, MS157, MS158, MS159, MS160, MS161, MS162, MS163, MS164, MS165, MS166, MS167, MS168, MS169, MS170, MS171, MS172, MS173, MS174, MS175, MS176, MS177, MS178, MS179, MS180, MS181, MS182, MS183, MS184, MS185, MS186, MS187, MS188, MS189, MS190, MS191, MS192, MS193, MS194, MS195, MS196, MS197, MS198, MS199, MS200, MS201, MS202, MS203, MS204, MS205, MS206, MS207, MS208, MS209, MS210, MS211, MS212, MS213, MS214, MS215, MS216, MS217, MS218, MS219, MS220, MS221, MS222, MS223, MS224, MS225, MS226, MS227, MS228, MS229, MS230, MS231, MS232, MS233, MS234, MS235, MS236, MS237, MS238, MS239, MS240, MS241, MS242, MS243, MS244, MS245, MS246, MS247, MS248, MS249, MS250, MS251, MS252, MS253, MS254, MS255, MS256, MS257, MS258, MS259, MS260, MS261, MS262, MS263, MS264, MS265, MS266, MS267, MS268, MS269, MS270, MS271, MS272, MS273, MS274, MS275, MS276, MS277, MS278, MS279, MS280, MS281, MS282, MS283, MS284, MS285, MS286, MS287, MS288, MS289, MS290, MS291, MS292, MS293, MS294, MS295, MS296, MS297, MS298, MS299, MS300, MS301, MS302, MS303, MS304, MS305, MS306, MS307, MS308, MS309, MS310, MS311, MS312, MS313, MS314, MS315, MS316, MS317, MS318, MS319, MS320, MS321, MS322, MS323, MS324, MS325, MS326, MS327, MS328, MS329, MS330, MS331, MS332, MS333, MS334, MS335, MS336, MS337, MS338, MS339, MS340, MS341, MS342, MS343, MS344, MS345, MS346, MS347, MS348, MS349, MS350, MS351, MS352, MS353, MS354, MS355, MS356, MS357, MS358, MS359, MS360, MS361, MS362, MS363, MS364, MS365, MS366, MS367, MS368, MS369, MS370, MS371, MS372, MS373, MS374, MS375, MS376, MS377, MS378, MS379, MS380, MS381, MS382, MS383, MS384, MS385, MS386, MS387, MS388, MS389, MS390, MS391, MS392, MS393, MS394, MS395, MS396, MS397, MS398, MS399, MS400, MS401, MS402, MS403, MS404, MS405, MS406, MS407, MS408, MS409, MS410, MS411, MS412, MS413, MS414, MS415, MS416, MS417, MS418, MS419, MS420, MS421, MS422, MS423, MS424, MS425, MS426, MS427, MS428, MS429, MS430, MS431, MS432, MS433, MS434, MS435, MS436, MS437, MS438, MS439, MS440, MS441, MS442, MS443, MS444, MS445, MS446, MS447, MS448, MS449, MS450, MS451, MS452, MS453, MS454, MS455, MS456, MS457, MS458, MS459, MS460, MS461, MS462, MS463, MS464, MS465, MS466, MS467, MS468, MS469, MS470, MS471, MS472, MS473, MS474, MS475, MS476, MS477, MS478, MS479, MS480, MS481, MS482, MS483, MS484, MS485, MS486, MS487, MS488, MS489, MS490, MS491, MS492, MS493, MS494, MS495, MS496, MS497, MS498, MS499, MS500, MS501, MS502, MS503, MS504, MS505, MS506, MS507, MS508, MS509, MS510, MS511, MS512, MS513, MS514, MS515, MS516, MS517, MS518, MS519, MS520, MS521, MS522, MS523, MS524, MS525, MS526, MS527, MS528, MS529, MS530, MS531, MS532, MS533, MS534, MS535, MS536, MS537, MS538, MS539, MS540, MS541, MS542, MS543, MS544, MS545, MS546, MS547, MS548, MS549, MS550, MS551, MS552, MS553, MS554, MS555, MS556, MS557, MS558, MS559, MS560, MS561, MS562, MS563, MS564, MS565, MS566, MS567, MS568, MS569, MS570, MS571, MS572, MS573, MS574, MS575, MS576, MS577, MS578, MS579, MS580, MS581, MS582, MS583, MS584, MS585, MS586, MS587, MS588, MS589, MS590, MS591, MS592, MS593, MS594, MS595, MS596, MS597, MS598, MS599, MS600, MS601, MS602, MS603, MS604, MS605, MS606, MS607, MS608, MS609, MS610, MS611, MS612, MS613, MS614, MS615, MS616, MS617, MS618, MS619, MS620, MS621, MS622, MS623, MS624, MS625, MS626, MS627, MS628, MS629, MS630, MS631, MS632, MS633, MS634, MS635, MS636, MS637, MS638, MS639, MS640, MS641, MS642, MS643, MS644, MS645, MS646, MS647, MS648, MS649, MS650, MS651, MS652, MS653, MS654, MS655, MS656, MS657, MS658, MS659, MS660, MS661, MS662, MS663, MS664, MS665, MS666, MS667, MS668, MS669, MS670, MS671, MS672, MS673, MS674, MS675, MS676, MS677, MS678, MS679, MS680, MS681, MS682, MS683, MS684, MS685, MS686, MS687, MS688, MS689, MS690, MS691, MS692, MS693, MS694, MS695, MS696, MS697, MS698, MS699, MS700, MS701, MS702, MS703, MS704, MS705, MS706, MS707, MS708, MS709, MS710, MS711, MS712, MS713, MS714, MS715, MS716, MS717, MS718, MS719, MS720, MS721, MS722, MS723, MS724, MS725, MS726, MS727, MS728, MS729, MS730, MS731, MS732, MS733, MS734, MS735, MS736, MS737, MS738, MS739, MS740, MS741, MS742, MS743, MS744, MS745, MS746, MS747, MS748, MS749, MS750, MS751, MS752, MS753, MS754, MS755, MS756, MS757, MS758, MS759, MS760, MS761, MS762, MS763, MS764, MS765, MS766, MS767, MS768, MS769, MS770, MS771, MS772, MS773, MS774, MS775, MS776, MS777, MS778, MS779, MS780, MS781, MS782, MS783, MS784, MS785, MS786, MS787, MS788, MS789, MS790, MS791, MS792, MS793, MS794, MS795, MS796, MS797, MS798, MS799, MS800, MS801, MS802, MS803, MS804, MS805, MS806, MS807, MS808, MS809, MS810, MS811, MS812, MS813, MS814, MS815, MS816, MS817, MS818, MS819, MS820, MS821, MS822, MS823, MS824, MS825, MS826, MS827, MS828, MS829, MS830, MS831, MS832, MS833, MS834, MS835, MS836, MS837, MS838, MS839, MS840, MS841, MS842, MS843, MS844, MS845, MS846, MS847, MS848, MS849, MS850, MS851, MS852, MS853, MS854, MS855, MS856, MS857, MS858, MS859, MS860, MS861, MS862, MS863, MS864, MS865, MS866, MS867, MS868, MS869, MS870, MS871, MS872, MS873, MS874, MS875, MS876, MS877, MS878, MS879, MS880, MS881, MS882, MS883, MS884, MS885, MS886, MS887, MS888, MS889, MS890, MS891, MS892, MS893, MS894, MS895, MS896, MS897, MS898, MS899, MS900, MS901, MS902, MS903, MS904, MS905, MS906, MS907, MS908, MS909, MS910, MS911, MS912, MS913, MS914, MS915, MS916, MS917, MS918, MS919, MS920, MS921, MS922, MS923, MS924, MS925, MS926, MS927, MS928, MS929, MS930, MS931, MS932, MS933, MS934, MS935, MS936, MS937, MS938, MS939, MS940, MS941, MS942, MS943, MS944, MS945, MS946, MS947, MS948, MS949, MS950, MS951, MS952, MS953, MS954, MS955, MS956, MS957, MS958, MS959, MS960, MS961, MS962, MS963, MS964, MS965, MS966, MS967, MS968, MS969, MS970, MS971, MS972, MS973, MS974, MS975, MS976, MS977, MS978, MS979, MS980, MS981, MS982, MS983, MS984, MS985, MS986, MS987, MS988, MS989, MS990, MS991, MS992, MS993, MS994, MS995, MS996, MS997, MS998, MS999, MS1000.

1 phases (10 to 16kW)

CODE	PART NAME
T2	Temperature sensor for refrigerant liquid
T7B	Temperature sensor for refrigerant gas
T.W.in	Temp. sensor for inlet water
T.W.out	Temp. sensor for outlet water
T1	Temp. sensor for condenser water
T2	Temp. sensor for evaporator water
T3	Temp. sensor for heating cooling water
T4	Temp. sensor for cooling water
T5	Temp. sensor for heating water
T6	Temp. sensor for cooling water
T7	Temp. sensor for heating water
T8	Temp. sensor for cooling water
KT1	Pressure sensor
KT2	Pressure sensor
KT3	Pressure sensor
KT4	Pressure sensor
KT5	Pressure sensor
KT6	Pressure sensor
KT7	Pressure sensor
KT8	Pressure sensor
KT9	Pressure sensor
KT10	Pressure sensor
KT11	Pressure sensor
KT12	Pressure sensor
KT13	Pressure sensor
KT14	Pressure sensor
KT15	Pressure sensor
KT16	Pressure sensor
KT17	Pressure sensor
KT18	Pressure sensor
KT19	Pressure sensor
KT20	Pressure sensor
KT21	Pressure sensor
KT22	Pressure sensor
KT23	Pressure sensor
KT24	Pressure sensor
KT25	Pressure sensor
KT26	Pressure sensor
KT27	Pressure sensor
KT28	Pressure sensor
KT29	Pressure sensor
KT30	Pressure sensor
KT31	Pressure sensor
KT32	Pressure sensor
KT33	Pressure sensor
KT34	Pressure sensor
KT35	Pressure sensor
KT36	Pressure sensor
KT37	Pressure sensor
KT38	Pressure sensor
KT39	Pressure sensor
KT40	Pressure sensor
KT41	Pressure sensor
KT42	Pressure sensor
KT43	Pressure sensor
KT44	Pressure sensor
KT45	Pressure sensor
KT46	Pressure sensor
KT47	Pressure sensor
KT48	Pressure sensor
KT49	Pressure sensor
KT50	Pressure sensor
KT51	Pressure sensor
KT52	Pressure sensor
KT53	Pressure sensor
KT54	Pressure sensor
KT55	Pressure sensor
KT56	Pressure sensor
KT57	Pressure sensor
KT58	Pressure sensor
KT59	Pressure sensor
KT60	Pressure sensor
KT61	Pressure sensor
KT62	Pressure sensor
KT63	Pressure sensor
KT64	Pressure sensor
KT65	Pressure sensor
KT66	Pressure sensor
KT67	Pressure sensor
KT68	Pressure sensor
KT69	Pressure sensor
KT70	Pressure sensor
KT71	Pressure sensor
KT72	Pressure sensor
KT73	Pressure sensor
KT74	Pressure sensor
KT75	Pressure sensor
KT76	Pressure sensor
KT77	Pressure sensor
KT78	Pressure sensor
KT79	Pressure sensor
KT80	Pressure sensor
KT81	Pressure sensor
KT82	Pressure sensor
KT83	Pressure sensor
KT84	Pressure sensor
KT85	Pressure sensor
KT86	Pressure sensor
KT87	Pressure sensor
KT88	Pressure sensor
KT89	Pressure sensor
KT90	Pressure sensor
KT91	Pressure sensor
KT92	Pressure sensor
KT93	Pressure sensor
KT94	Pressure sensor
KT95	Pressure sensor
KT96	Pressure sensor
KT97	Pressure sensor
KT98	Pressure sensor
KT99	Pressure sensor
KT100	Pressure sensor

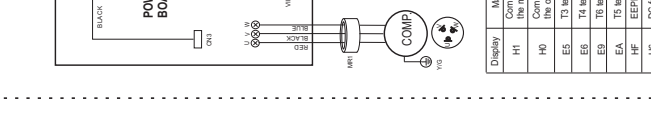
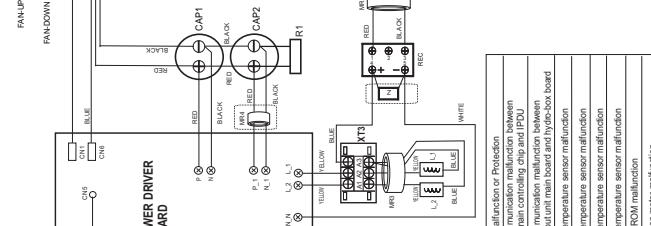
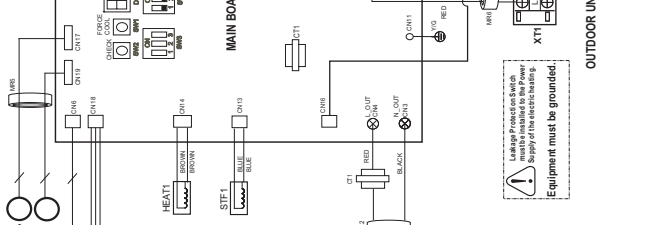
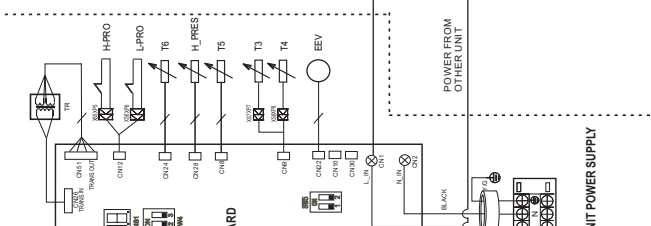
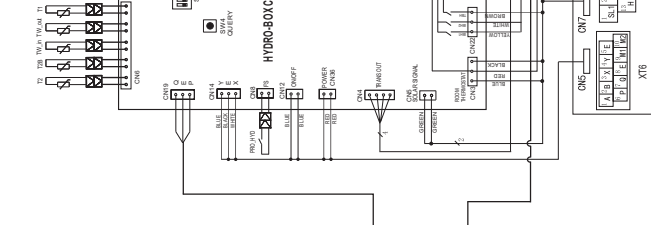
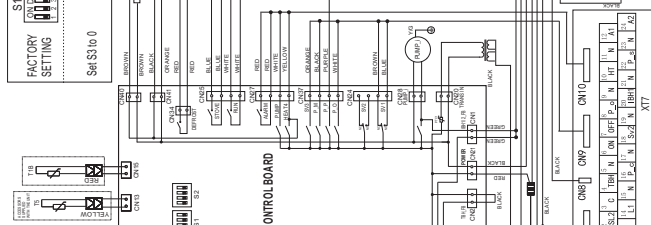
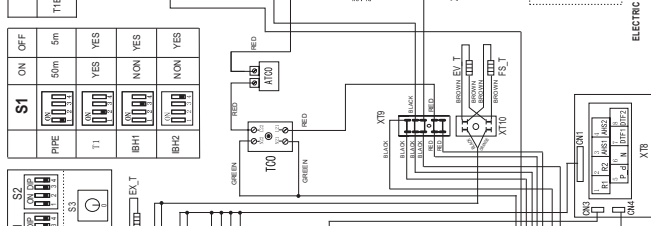
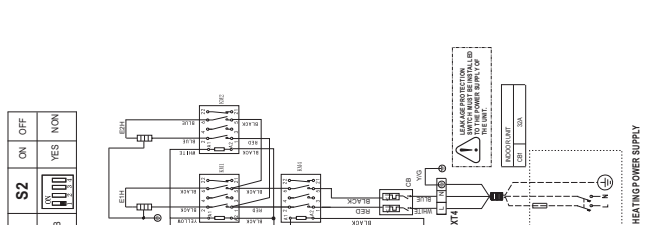

Sequence	Content
0	Normal display OFF (ON/T1) (Show 'Heat' on T1 valve and 'Cooling' on T1 valve or T11 fault)
1	Mode (00Z/00Z) (Heat/Cooling valve)
2	Capacity Requirements
3	Capacity Requirements (Cont)
4	T1
5	T1B
6	T1S
7	T1
8	T1S
9	T2
10	T2B
11	T1.W.in
12	T1.W.out
13	T4
14	Current I(BH)
15	Current I(BH)
16	Last fault
17	Last second failure
18	Last third failure
19	Software version
20	---

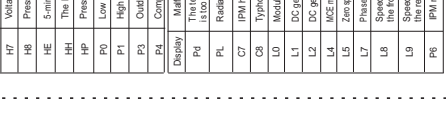
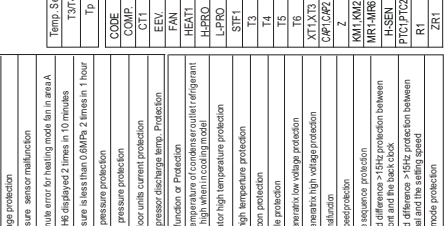
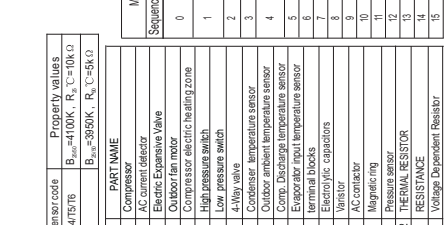
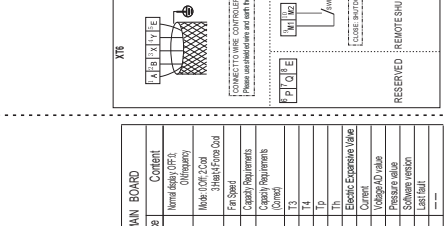
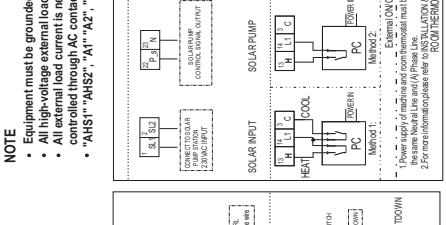
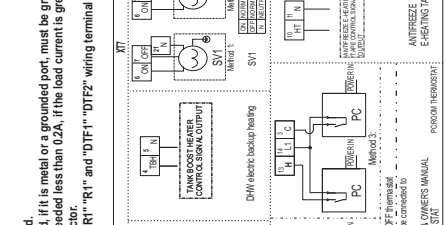
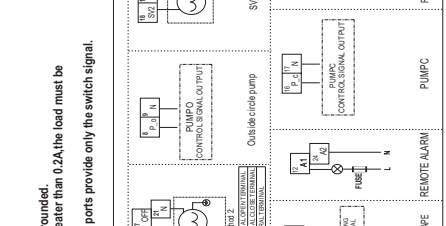
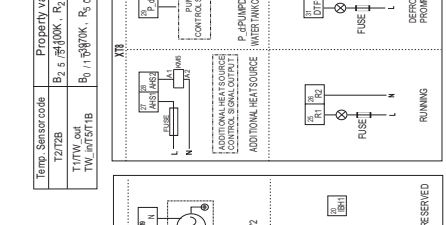

Temp. Sensor code	Property values
T2/T7B	B <sub>2</sub> = 5100K, R <sub>2</sub> = 10K, C <sub>2</sub> = 10K
T1	B <sub>1</sub> = 10000K, R <sub>1</sub> = 17.5K, C <sub>1</sub> = 17.5K
T1.W.in/T1B	B <sub>1</sub> = 10000K, R <sub>1</sub> = 17.5K, C <sub>1</sub> = 17.5K

NOTE

- Equipment must be grounded.
- All high-voltage external load, fit it metal or a grounded port, must be grounded.
- All external load current is needed less than 0.2A, if the load current is greater than 0.2A, the load must be grounded.
- AH1S1 "AH1S2", A1 "A2", R1 "R1" and "DTF1" "DTF2" wiring terminal ports provide only the switch signal.

1 phases (10 to 16kW)

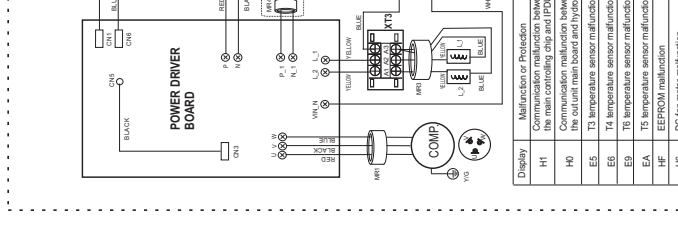

Sequence	Content
0	Temperature (°F)
1	Temperature (°C)
2	Mode (00Z/00Z) (Heat/Cooling valve)
3	Capacity Requirements
4	Capacity Requirements (Cont)
5	T1
6	T1B
7	T1S
8	T1
9	T2
10	T2B
11	T1.W.in
12	T1.W.out
13	T4
14	Current I(BH)
15	Current I(BH)
16	Last fault
17	Last second failure
18	Last third failure
19	Software version
20	---

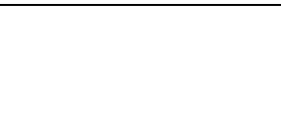

3 phases (12 to 16kW)

**HYDRO-BOX CONTROL BOARD**

Sequence	Part Name	Content
0	Normal display OFF/ON(T1)	Show 'Noct' when T1 is not set or T1 is set
1	Temp. sensor for refrigerant liquid (T2)	Temp. sensor for refrigerant liquid (T2)
2	Temp. sensor for condenser (T3)	Temp. sensor for condenser (T3)
3	Temp. sensor for evaporator (T4)	Temp. sensor for evaporator (T4)
4	Temp. sensor for hot water (T5)	Temp. sensor for hot water (T5)
5	Temp. sensor for cold water (T6)	Temp. sensor for cold water (T6)
6	Temp. sensor for hot water (T7)	Temp. sensor for hot water (T7)
7	Temp. sensor for cold water (T8)	Temp. sensor for cold water (T8)
8	Temp. sensor for hot water (T9)	Temp. sensor for hot water (T9)
9	Temp. sensor for cold water (T10)	Temp. sensor for cold water (T10)
10	Temp. sensor for hot water (T11)	Temp. sensor for hot water (T11)
11	Temp. sensor for cold water (T12)	Temp. sensor for cold water (T12)
12	Temp. sensor for hot water (T13)	Temp. sensor for hot water (T13)
13	Temp. sensor for cold water (T14)	Temp. sensor for cold water (T14)
14	Temp. sensor for hot water (T15)	Temp. sensor for hot water (T15)
15	Temp. sensor for cold water (T16)	Temp. sensor for cold water (T16)
16	Temp. sensor for hot water (T17)	Temp. sensor for hot water (T17)
17	Temp. sensor for cold water (T18)	Temp. sensor for cold water (T18)
18	Temp. sensor for hot water (T19)	Temp. sensor for hot water (T19)
19	Temp. sensor for cold water (T20)	Temp. sensor for cold water (T20)
20	Temp. sensor for hot water (T21)	Temp. sensor for hot water (T21)

**MAIN CONTROL BOARD**

Sequence	Content
0	Normal display OFF/ON frequency
1	Main L/OV (Cold)
2	Fan Speed
3	Capacity Requirements
4	Capacity Requirements
5	Capacity Requirements
6	Capacity Requirements
7	Capacity Requirements
8	Capacity Requirements
9	Capacity Requirements
10	Capacity Requirements
11	Capacity Requirements
12	Capacity Requirements
13	Capacity Requirements
14	Capacity Requirements
15	Capacity Requirements

**HYDRO-BOX CONTROL BOARD**

**MAIN CONTROL BOARD**

**OUTDOOR UNIT POWER SUPPLY**

Display	Malfunction or Protection
Pd	Outdoor unit exchanger temperatures (T3) too high protect
PL	Transducer module radiator temperature
P3	Compressor current protect
P4	Compressor discharge temp. Too high protect
P6	Transducer module (PM) protect
P9	DC fan motor protect
C7	Transducer module (PM) temperature too high protect
L0	Module protection
L1	DC generate low voltage protection
L2	DC generate high voltage protection
L4	ME malfunctions
L5	Zone superheating
L7	Speed of fan too high
L8	Speed of fan too low
L9	Speed reference > 16Hz protection between the real and the setting speed

**NOTE**

- Equipment must be grounded.
- All high-voltage external load, if it is metal or a grounded part, must be grounded.
- External load current is needed less than 0.5A, if the load current is greater than 0.5A, the load must be grounded.
- External load current is needed less than 0.5A, if the load current is greater than 0.5A, the load must be grounded.
- PHS1, PHS2, A, AZ, RT, RT and DT1, DT2, DT3, DT4, DT5, DT6, DT7, DT8, DT9, DT10, DT11, DT12, DT13, DT14, DT15, DT16, DT17, DT18, DT19, DT20, DT21, DT22, DT23, DT24, DT25, DT26, DT27, DT28, DT29, DT30, DT31, DT32, DT33, DT34, DT35, DT36, DT37, DT38, DT39, DT40, DT41, DT42, DT43, DT44, DT45, DT46, DT47, DT48, DT49, DT50, DT51, DT52, DT53, DT54, DT55, DT56, DT57, DT58, DT59, DT60, DT61, DT62, DT63, DT64, DT65, DT66, DT67, DT68, DT69, DT70, DT71, DT72, DT73, DT74, DT75, DT76, DT77, DT78, DT79, DT80, DT81, DT82, DT83, DT84, DT85, DT86, DT87, DT88, DT89, DT90, DT91, DT92, DT93, DT94, DT95, DT96, DT97, DT98, DT99, DT100.

**ANNEX 2: TABLE FOR SERVICEMAN**

N°	Code	Description	Value	Default value	Range	Step	Unit
<b>1. DHW MODE SETTING</b>							
1.1	DHW MODE	The selection of whether DHW mode is available		YES	YES/NON	-	-
1.1.1	dT5_ON	Temperature difference between T5 (actual temp. of DHW) and T5S (target temp. of DHW) for turn the unit ON ( $T5 \leq T5S - dT5\_ON$ )		5	2 ~ 10	1	°C
1.1.2	dT1S5	The correct value for T1S (target outlet water temp.) ( $T1S = T5 + dT1S5$ )		10	5 ~ 20	1	°C
1.1.3	T4DHWMAX	The maximum operating ambient temp.		43	35 ~ 43	1	°C
1.1.4	T4DHWMIN	The minimum operating ambient temp.		-10	-20 ~ 5	1	°C
1.1.5	t_INTERVAL DHW	The compressor start time interval		5	5 ~ 30	1	min
1.2	TANK HEATER	The selection of whether TANK HEATER is available		YES	YES/NON	-	-
1.2.1	dT5_TBH_OFF	Temp. difference between T5 and T5S that turn the tank heater OFF ( $T5 \geq T5S + dT5\_TBH\_OFF$ )		5	2 ~ 10	1	°C
1.2.2	T4_TBH_ON	The temp. only when the ambient temperature lower than it the tank heater will operate		5	-5 ~ 20	1	°C
1.2.3	t_TBH_DELAY	The time that the compressor has run before starting the tank heater		90	60 ~ 240	5	min
1.3	DISINFECT	The selection of whether DISINFECT mode is available		YES	YES/NON	-	-
1.3.1	T5S_DI	The setting temp. of water in the domestic water tank		65	60 ~ 70	1	°C
1.3.2	t_DI_HIGHTEMP.	The time high temp. of water to be lasted		15	5 ~ 45	5	min
1.3.3	t_DI_MAX	The time that desinfection to be lasted		210	90 ~ 300	5	min
1.4	DHW PRIORITY	The selection of whether DHW priority is available		YES	YES/NON	-	-
1.4.1	t_DHWHP_MAX	The maximum operation time of heat pump		180	60 ~ 600	5	min
1.4.2	t_DHWHP_RESTRICT	The operation time for space heating/cooling operation		180	60 ~ 600	5	min
1.5	DHW PUMP	The selection for whether the DHW pump is installed or not		NON	YES/NON	-	-
1.5.1	TIMER RUNNING	The selection for whether the DHW pump will run as timed		YES	YES/NON	-	-
1.5.2	DISINFECT	The selection for whether the DHW pump will run as disinfect mode is on		YES	YES/NON	-	-
1.5.3	PUMP RUNNING TIME	The pump running time		5	5 ~ 120	1	min
<b>2. COOL MODE SETTING</b>							
2.1	COOL MODE	The selection of whether space cool mode is available		YES	YES/NON	-	-
2.2	T1S RANGE	The range of target outlet water temp.		LOW	LOW/HIGH	-	-
2.3	T4CMAX	The maximum operating ambient temp.		43	35 ~ 46	1	°C
2.4	T4CMIN	The minimum operating ambient temp.		10	-5 ~ 25	1	°C
2.5	dT1SC	The temp. difference between T1 (actual outlet water temp.) and T1S (target outlet water temp.) for starting the unit ( $T1 \geq T1S + dT1SC$ )		5	2 ~ 10	1	°C
2.6	dTSC	The temp. difference between Ta (actual room temp.) and TS (target room temp.) for starting the unit when room thermostat is installed ( $T1 \geq T1S + dTSC$ )		2	1 ~ 10	1	°C
2.7	t_INTERVAL_C	The compressor start time interval		5	5 ~ 30	1	min
<b>3. HEAT MODE SETTING</b>							
3.1	HEAT MODE	The selection of whether space heat mode is available		YES	YES/NON	-	-
3.2	T1S RANGE	The range of target outlet water temp.		LOW	LOW/HIGH	-	-
3.3	T4HMAX	The maximum operating ambient temp.		25	10 ~ 30	1	°C
3.4	T4HMIN	The minimum operating ambient temp.		-15	-5 ~ 20	1	°C
3.5	dT1SH	The temp. difference between T1 (actual outlet water temp.) and T1S (target outlet water temp.) for starting the unit ( $T1 \leq T1S - dT1SH$ )		5	2 ~ 10	1	°C
3.6	dTSH	The temp. difference between Ta (actual room temp.) and TS (target room temp.) for starting the unit when room thermostat is installed ( $Ta \leq TS - dTSH$ )		2	1 ~ 10	1	°C
3.7	t_INTERVAL_h	The compressor start time interval		5	5 ~ 60	1	min



N°	Code	Description	Value	Default value	Range	Step	Unit
<b>4. AUTO MODE SETTING</b>							
4.1	T4AUTOCLMIN	The minimum operation ambient temperature for cooling		25	20 ~ 29	1	°C
4.2	T4AUTOHMAX	The maximum operation ambient temperature for heating		17	10 ~ 17	1	°C
<b>5. TEMP. TYPE SETTING</b>							
5.1	WATER FLOW TEMP.	The selection of whether the water temp. will be displayed on the home page		YES	YES/NON	-	-
5.2	ROOM TEMP.	The selection of whether the room temp. will be displayed on the home page		NON	YES/NON	-	-
<b>6. ROOM THERMOSTAT</b>							
6.1	ROOM THERMOSTAT	The selection of whether the room thermostat is available		NON	YES/NON	-	-
6.2	MODE SETTING	The selection for whether the mode setting is available by thermostat		NON	YES/NON	-	-
6.3	DUAL ROOM THERMOSTAT	The selection for whether the dual room thermostat is available		NON	YES/NON	-	-
<b>7. OTHER HEATING SOURCE</b>							
7.1	BACKUP HEATER	The selection for whether the inner hydrobox heater is available		YES	YES/NON	-	-
7.1.1	HEAT MODE	The selection for whether the backup heater will be used in space heating mode		YES	YES/NON	-	-
7.1.2	DHW MODE	The selection for whether the backup heater will be used in DHW mode		NON	YES/NON	-	-
7.1.3	T4_IBH_ON	The ambient temp. for starting the backup heater		-5	-15 ~ 10	1	°C
7.1.4	dT1_IBH_ON	The temp. difference between T1S (target outlet water temp.) and T1 (actual outlet water temp.) for starting the backup heater ( $T1 \leq T1S - dT1\_IBH\_ON$ )		5	2 ~ 10	1	°C
7.1.5	t_IBH_DELAY	The time that the compressor has run before the first backup heater turn ON		30	15 ~ 120	5	min
7.1.6	t_IBH12_DELAY	The time that the compressor has run before the second backup heater turn ON		5	5 ~ 30	5	min
7.2	AHS	The selection for whether the additional heating source is available		NON	YES/NON	-	-
7.2.1	HEAT MODE	The selection for whether the additional heating source will be used in space heating mode		YES	YES/NON	-	-
7.2.2	DHW MODE	The selection for whether the additional heating source will be used in DHW mode		NON	YES/NON	-	-
7.2.3	T4_AHS_ON	The ambient temp. for starting the AHS		-5	-15 ~ 10	1	°C
7.2.4	dT1_AHS_ON	The temp. difference between T1S (target outlet water temp.) and T1 (actual outlet water temp.) for turning the AHS ON ( $T1 \leq T1S - dT1\_AHS\_ON$ )		5	2 ~ 10	1	°C
7.2.5	dT1_AHS_OFF	The temp. difference between T1S (target outlet water temp.) and T1 (actual outlet water temp.) for turning the AHS OFF ( $T1 \geq T1S + dT1\_AHS\_OFF$ )		0	-5 ~ 0	1	°C
7.2.6	t_AHS_DELAY	The time that the compressor has run before starting the AHS		30	15 ~ 120	5	min
7.3	SOLAR ENERGY	The selection for whether the solar energy kit is available		NON	YES/NON	-	-
<b>8. HOLIDAY AWAY MODE SETTING</b>							
8.1	T1S_H.A_H	The target outlet water temp. for space heating		25	20 ~ 25	1	°C
8.2	T5S_H.M_DHW	The target outlet water temp. for DHW		25	15 ~ 25	1	°C

N°	Code	Description	Value	Default value	Range	Step	Unit
<b>9. SERVICE CALL SETTING</b>							
9.1	PHONE NO.	Phone number for service call		-	-	-	-
9.2	MOBILE NO.	Mobile number for service call		-	-	-	-
<b>10. RESTORE SETTINGS</b>							
10.1	RESTORE FACTORE SETTINGS	Restore factory settings		NON	YES/NON	-	-
<b>11. TEST RUN</b>							
11.1	POINT CHECK	Check function		-	-	-	-
11.2	AIR PURGE	Test the air purge function		-	-	-	-
11.3	CIRCULATED PUMP RUNNING	Test the circulated pump		-	-	-	-
11.4	COOL MODE RUNNING	Test the cool mode		-	-	-	-
11.5	HEAT MODE RUNNING	Test the heat mode		-	-	-	-
11.6	DHW MODE RUNNING	Test the DHW mode		-	-	-	-
<b>12. SPECIAL FUNCTION</b>							
12.1	AIR PURGE	Purge the air within the water circuit		-	-	-	-
12.2	PREHEATING FOR FLOOR	Preheating the floor		-	-	-	-
12.2.1	FLOW SET TEMPERATURE (T1S)	The target temp. of outlet water during preheating for floor		30	25 ~ 35	1	°C
12.2.2	RETURN TEMPERATURE (dT1SH)	The temp. difference between T1 (actual outlet water temp.) and T1S (target outlet water temp.) for turn the unit OFF ( $T1 \geq T1S + dT1SH$ )		5	2 ~ 10	1	°C
12.2.3	PREHEATING TIME (t_fristFH)	The time last for preheating for floor		72	48 ~ 96	1	h
12.2.4	OPERATE PREHEATING FOR FLOOR	The selection of start preheating for floor		NON	YES/NON	-	-
12.3	FLOOR DRYING UP	Drying up the floor		-	-	-	-
12.3.1	WARM UP TIME (t_DRYUP)	The day for warming up		8	4 ~ 15	1	day
12.3.2	KEEP TIME (t_HIGHPEAK)	The day for high temp. last		5	3 ~ 7	1	day
12.3.3	TEMP. DOWN TIME (t_DRY D)	The day for dropping temp.		5	4 ~ 15	1	day
12.3.4	PEAK TEMP. (t_DRYPEAK)	The target peak temp. of outlet water during floor drying up		45	30 ~ 55	1	day
12.3.5	START TIME	The time of floor drying up start		-	-	-	-
12.3.6	START DATE	The date of floor drying up start		-	-	-	-
12.3.7	OPERATE FLOOR DRYING UP	The selection of start drying up floor		NON	YES/NON	-	-
<b>13. AUTO RESTART</b>							
13.1	COOL/HEAT MODE	The selection of enable or disable auto restart function during cool/heat mode		YES	YES/NON	-	-
13.2	DHW MODE	The selection of enable or disable auto restart function during DHW mode		YES	YES/NON	-	-

MUNDO  CLIMA<sup>®</sup>  
*Aerotherm*



[www.mundoclima.com](http://www.mundoclima.com)

**ASK FOR MORE INFORMATION**

Phone: (+34) 93 446 27 81

eMail: [info@mundoclima.com](mailto:info@mundoclima.com)

**TECHNICAL ASSISTANCE**

Phone: (+34) 93 652 53 57