

DESHUMIDIFIER MH-N

User and installation manual

MH-60-N

MH-80-N

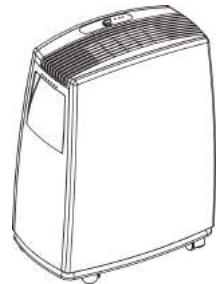

SAFETY INFORMATION

1. Please read the operating instructions carefully before using your dehumidifier for the first time and keep them in a safe place.
2. Never immerse the appliance in water or other liquids.
3. Never operate the appliance if a cable or connector has been damaged, after appliance malfunction or if the appliance was dropped or otherwise damaged.
4. Electric appliance may only be repaired by qualified personal, improper repair work can be a source of considerable danger for the users.
5. Children are not aware of the hazards of electric appliance. Therefore, never allow children to manipulate electric appliance unless properly supervised.
6. Disconnect the appliance from mains power whenever it is not in use, before relocating it, and before cleaning,
7. Operate the appliance only at the voltage specified on the type plate.
8. Use the appliance only in the household, and only for the purpose it was designed for.
9. Do not place heavy objects on the appliance.
10. To prevent spillage, empty the water tank before relocating the appliance.
11. Do not tip the appliance to any side as escaping water could damage the appliance.
12. This appliance is not intended for use by persons (including children) with reduced physical, sensory or mental capabilities, or lack of experience and knowledge, unless they have been given supervision or instruction concerning use of the appliance by a person responsible for their safety. Children should be supervised to ensure that they do not play with the appliance.
13. When the supply cord is damaged, it must be replaced by the manufacturer, its service agent or similarly qualified persons in order to avoid a hazard.
14. The devices should be installed at minimum distant of 50CM from the wall or other obstacle.
15. Unplug the appliance before cleaning.

OPERATING INSTRUCTIONS

1. Control panel
2. Air outlet
3. Handle
4. Front panel

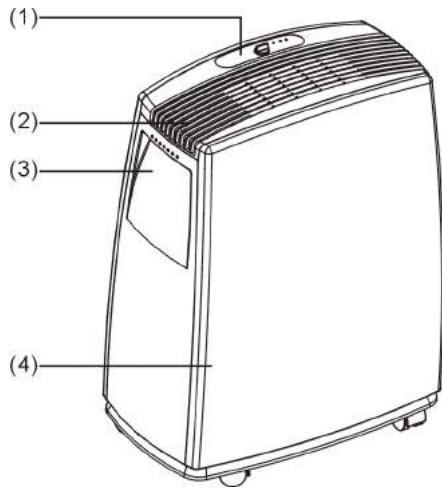

5. Back panel
6. Water out hole
7. Water tank

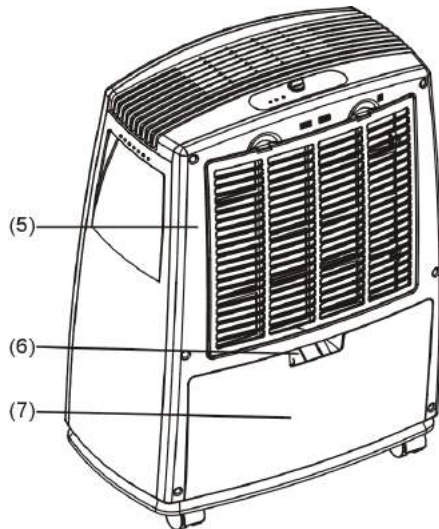

CONTROL PLATE DESCRIPTION

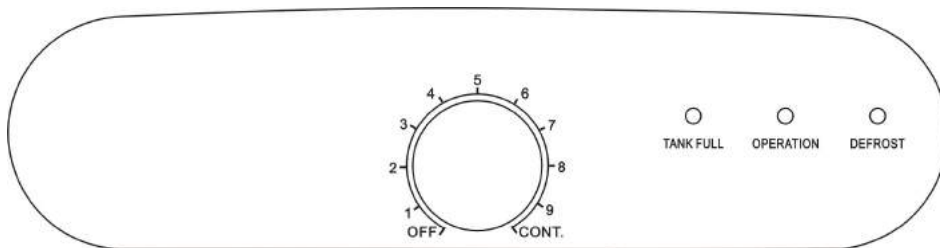

OPERATION INSTRUCTION

Starting the unit

1. Firstly, turn the humidity control switch to the “OFF” position.
2. Plug in the dehumidifier.
3. Turn on the humidity control switch(to right side) and turn the same switch to the reading of the desired humidity(60% in general as shown on position”4”).

Turning off the unit

1. Turn the humidity control switch to the left side to the “OFF” position and the power supply is cut off and the unit stops in operation.
2. If the dehumidifier is not in use for a long time, please disconnect the power cord plug from the outlet.

PRECAUTIONS

1. The dehumidifier shall not operate if the humidity setting is higher than the ambient humidity.
2. Drain the water in the water storage tank when the water in the tank is full and the water level indicator light illuminates. And then install the empty water tank back to its position, so the unit can continue its operation.
3. When the unit stops, you have to wait for 3 minutes before you can restart the unit to protect the compressor from damage.
4. The humidify and its related position number on the humidity control switch:

CONTROL SWITCH POSITION NO.	APPROXIMATE HUMIDITY SETTING
8	20%
7	30%
6	40%
4	60%
2	80%

5. The operational temperature range for this unit is 5-32°C.
6. If the dehumidifier does not start (the operational light does not illuminate) or the dehumidifier makes intermediate stop on unknown reasons, please check the plug and power supply for poor connection. If the plug and power supply are in normal condition, wait for 10 minutes and restart the unit (because take about 10 minutes to reposition). If the unit still does not starts in 10 minutes, please contact your local distributor service station for repair.
7. When the dehumidifier is in operation, the running compressor will produce heat and make the room temperature higher. This is normal condition.
- 8 . defrost light on is to indicate the operation of defrost is start. During this operation mode, compressor will be switched off and air motor will be turned on.

DRAINAGE INSTRUCTION

The extracted water can be collected by water tank, or drained continuously with a PVC hose (not available):

USE OF WATER TANK:

When the water full indicator illuminates, the tank is full, and the compressor and the fan will stop operation, please empty the water tank:

1. Remove the water tank as Fig 01. and empty it.
2. Insert gently the water tank into the unit reach to its original position.

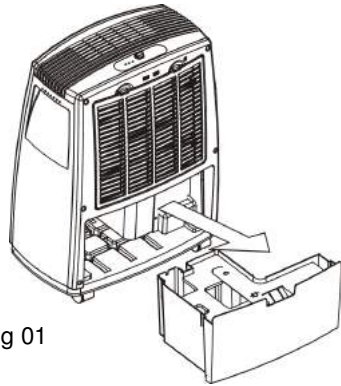

Fig 01

CONTINUOUS DRAINAGE

1. When you want to use this function, please Pull out the water tank, and plug the discharge water pipe in “Water out hole” (See Fig.02). replace the water tank into the unit, then you can operate the unit.

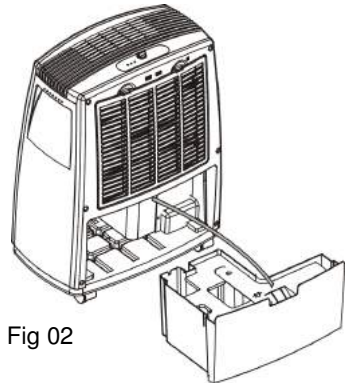
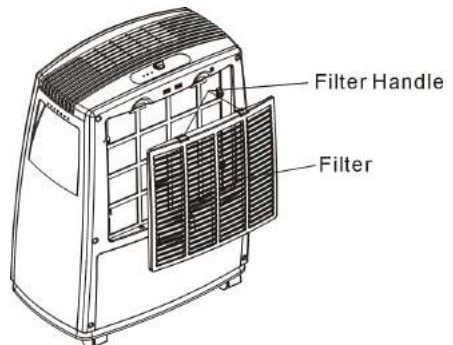

Fig 02

Filter Removal

- The filter can be removed from its slot by gripping the filter handle and sliding it out from the back of the appliance.
- Every 2 weeks, remove the filter and clean it with warm water, below 40 °C. Allow it to dry naturally and then replace.



Maintenance Instruction

1. The unit is not allow to be located on the floor of soft and uneven surface when the unit is in operation to avoid occurrence of vibration and noise.
2. Never insert any slim rod and hard object into the unit body to avoid occurrence of hazard or unit failure.
3. During power off or when not in use for a long time, please pull out the power cord from the outlet.

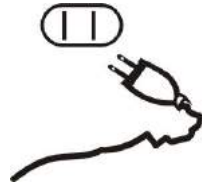
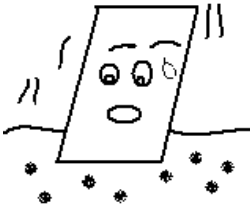

4. For a better dehumidifying effect, the areas in front and rear of the unit should be clear and free from obstacles, which will block the air flow for the unit.
5. Clean the filtering net once every two weeks (never use alcohol, gasoline, on or hot water with a temperature of 40 degrees C.

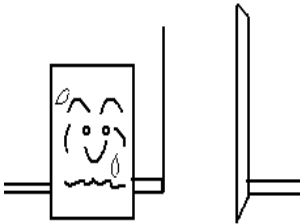

SPECIFICATIONS

MODEL	MH-60-N	MH-80-N
SPECIFICATION		
POWER SOURCE	220-240V~50Hz	
RATED POWER INPUT(EN60335)	1150W	1350W
RUNNING CURRENT	5.1A	6.2A
NET WEIGHT	22,5Kg	23Kg
MOISTURE REMOVAL (30°C RH 80%)	60 L/day	80 L/day
DIMENSION (W x D x H)	481 x 286 x 628mm	
TEMP. RANGE FOR USE	5°C-32 °C	
WATER TANK CAPACITY	7.2L	

(CE) N 842/2006:

R410A is a kind of fluorinated greenhouse gases covered by the Kyoto Protocol.

Its total global warming potential (GWP) is 2088



This marking indicates that this product should not be disposed of with other household wastes throughout the EU. To prevent possible harm to the environment or human health from uncontrolled waste disposal, recycle responsibly to promote the sustainable reuse of material resources. To return your used device, please use the return and collection systems or contact the retailer where the product was purchased. They can take this product for environmental safe recycling.

MUNDO  CLIMA®



www.mundoclima.com

ASK FOR MORE INFORMATION

Phone: (+34) 93 446 27 81

eMail: info@mundoclima.com

TECHNICAL ASSISTANCE

Phone: (+34) 93 652 53 57