

MINI CHILLER INVERTER H6

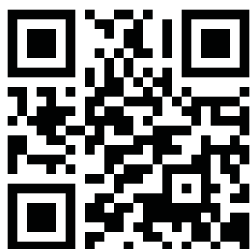











































Installation & Owner's manual
and information requirements

MUENR-H6

(5, 7 kW)



INDEX

  	<u>General warnings</u>	<u>2</u>	 	<u>Refrigerant circuit</u>	<u>17</u>
  	<u>Fundamental safety rules</u>	<u>2</u>		<u>Checking and starting up the unit</u>	<u>18</u>
	<u>Description of standard unit</u>	<u>3</u>	  	<u>Activating and deactivating the unit</u>	<u>18</u>
	<u>Dimensioned drawings</u>	<u>4</u>		<u>Shutting down for long periods</u>	<u>23</u>
	<u>Installation</u>	<u>4</u>		<u>Routine maintenance</u>	<u>23</u>
 	<u>Hydraulic connections</u>	<u>6</u>		<u>Extraordinary maintenance</u>	<u>23</u>
 	<u>Electrical connections</u>	<u>9</u>	 	<u>Operating characteristics</u>	<u>24</u>
 	<u>Operation limits</u>	<u>13</u>		<u>Disposal</u>	<u>25</u>
 	<u>Protection the water circuit against freezing</u>	<u>14</u>	 	<u>Troubleshooting</u>	<u>25</u>
 	<u>Hydraulic data</u>	<u>15</u>	 	<u>Specifications</u>	<u>27</u>
 	<u>Filling with water</u>	<u>17</u>	  	<u>Important information for the used refrigerant</u>	<u>28</u>
 	<u>Failure diagnosis at the moment of first installation</u>	<u>17</u>	  	<u>Information requirements</u>	<u>29</u>

The following symbols are used in this publication and inside the unit:



User



Important



Danger moving blades



Installer



Prohibition



Danger high temperatures



Assistance



Danger voltage

 These units have been designed to chill and/or heat water and must be used in applications compatible with their performance characteristics; these appliances are designed for residential or similar applications.

Incorrect installation, regulation and maintenance or improper use absolve the manufacturer from all liability, whether contractual or otherwise, for damage to people, animals or things. Only those applications specifically indicated in this list are permitted. Read this manual carefully. All work must be carried out by qualified personnel in conformity with legislation in force in the country concerned.

The guarantee is invalidated if the above instructions are not respected and if the unit is started up for the first time without the presence of personnel authorised by the Company (where specified in the

supply contract) who should draw up a "start-up" report.

The documentation supplied with the unit must be consigned to the owner who should keep it carefully for future consultation in the event of maintenance of service.

All repair or maintenance work must be carried out by the Company's Technical Service or qualified personnel following the instructions in this manual. The air-conditioner must under no circumstances be modified or tampered with as this may create situations of risk. Failure to observe this condition absolves the manufacturer of all liability for resulting damage.

FUNDAMENTAL SAFETY RULES

When operating equipment involving the use of electricity and water, a number of fundamental safety rules must be observed, namely:

 This appliance is not intended for use by persons (including children) with reduced physical, sensory or mental capabilities, or lack of experience and knowledge, unless they have been given supervision or instruction concerning use of the appliance by a person responsible for their safety.

Do not touch the unit with bare feet or with wet or damp parts of the body

Do not carry out cleaning operations without first disconnecting the system from the electricity supply.

Do not modify safety or regulation devices without authorisation and instructions from the manufacturer.

Do not pull, detach or twist the electrical cables coming from the unit, even when disconnected from the mains electricity supply.

Do not open doors or panels providing access to the internal parts of the unit without first ensuring that the mains switch is in the off position.

Do not introduce pointed objects through the air intake and outlet grills.

Do not dispose of, abandon or leave within reach of children packaging materials (cardboard, staples, plastic bags, etc.) as they may represent a hazard.

 The chiller appliances are supplied without the main switch. The power supply to the unit must be disconnected using a suitable main switch that must be supplied and installed by the installer.

 Respect safety distances between the unit and other equipment or structures. Guarantee adequate space for access to the unit for maintenance and/or service operations;
Power supply: the cross section of the electrical cables must be adequate for the power of the unit and the power supply voltage must correspond with the value indicated on the respective units. All units must be earthed in conformity with legislation in force in the country concerned.

 Hydraulic connections should be carried out as indicated in the instructions to guarantee correct operation of the unit. Empty the water circuit or add glycol if the unit is not used during the winter. Handle the unit with the utmost care to avoid damage.

These air cooled reverse-cycle chillers with axial-flow fans operate with refrigerant fluid and are suitable for outdoor installation.

They are factory tested and on site installation is limited to water and electrical connections.

STRUCTURE

Panels and base are made from galvanised steel plate painted with epoxy powder to ensure total resistance to atmospheric agents. Condensate collection pan as standard.

COMPRESSORS

Hermetic DC inverter compressor with crankcase heater and thermal cut-out .

EVAPORATOR

AISI 316 stainless steel plate type evaporator complete with electric heater and water flow switch. Casing lined with anti-condensate closed cell neoprene cladding.

PUMPS

The units feature a pump with the moving parts in contact with the water made from corrosion resistant materials, extra wear ring on the impeller, built-in capacitor for high starting torque and automatic venting of impeller chamber.

PUMP ASSEMBLY

Pump assembly with expansion tank, safety valve, auto-water replenishing assembly, pressure gauge and pump.

CONDENSING COILS

Made from copper tubes and high surface area aluminium fins. Condensing coil protection grills as standard.

FANS

Axial-flow fans. DC motor with built-in thermal cut-out. Housed in aerodynamic tubes with accident prevention grill.

Device for operation with low outside air temperatures: continuous fan rotation speed control via condensing temperatures transducer.

POWER AND CONTROL ELECTRICAL PANEL

Power and control electrical panel constructed in accordance with IEC 204-1/EN60335-2-40.

OPTIONAL ACCESSORIES AND FUNCTIONS

- Remote shutdown (ON/OFF)
- Remote cooling/heating
- Additional pump
- Remote alarm
- Wire controller (CL92340)

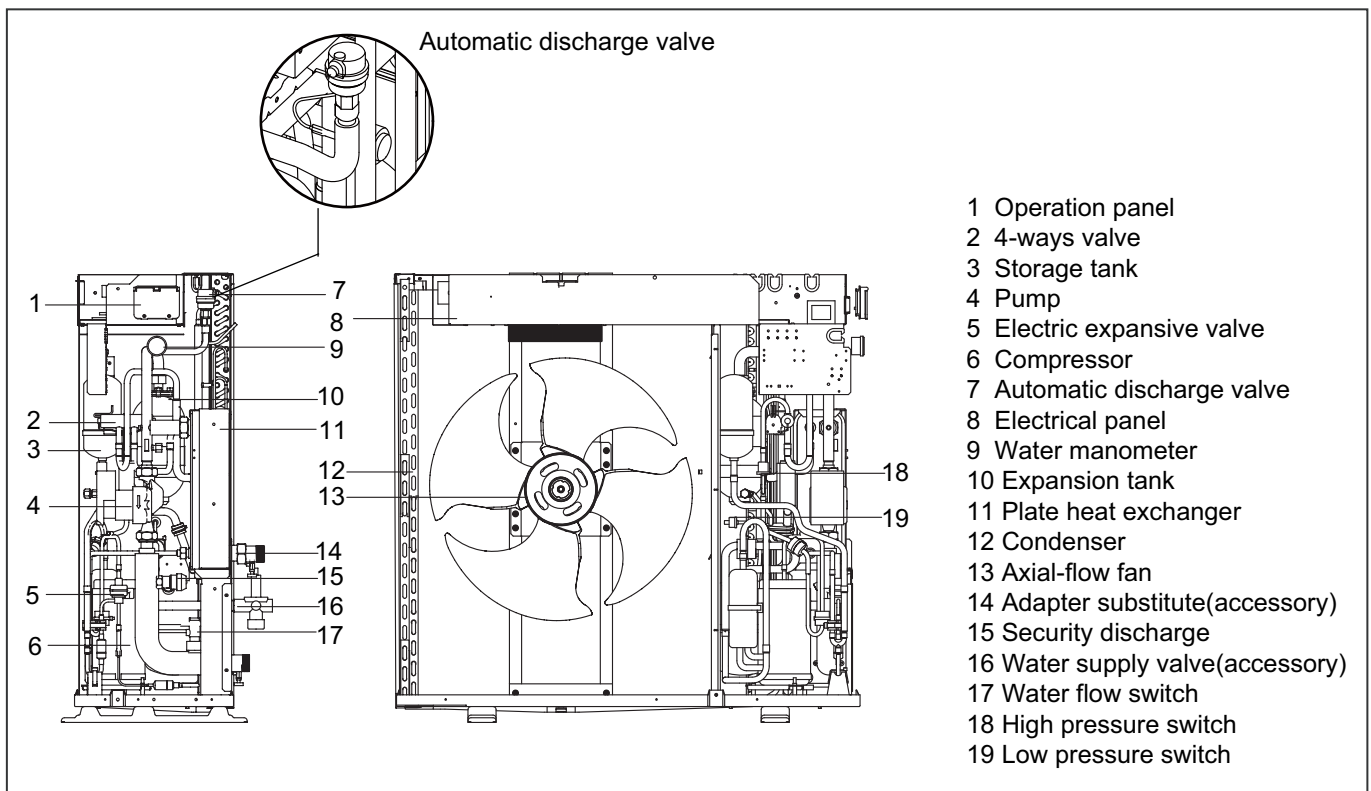

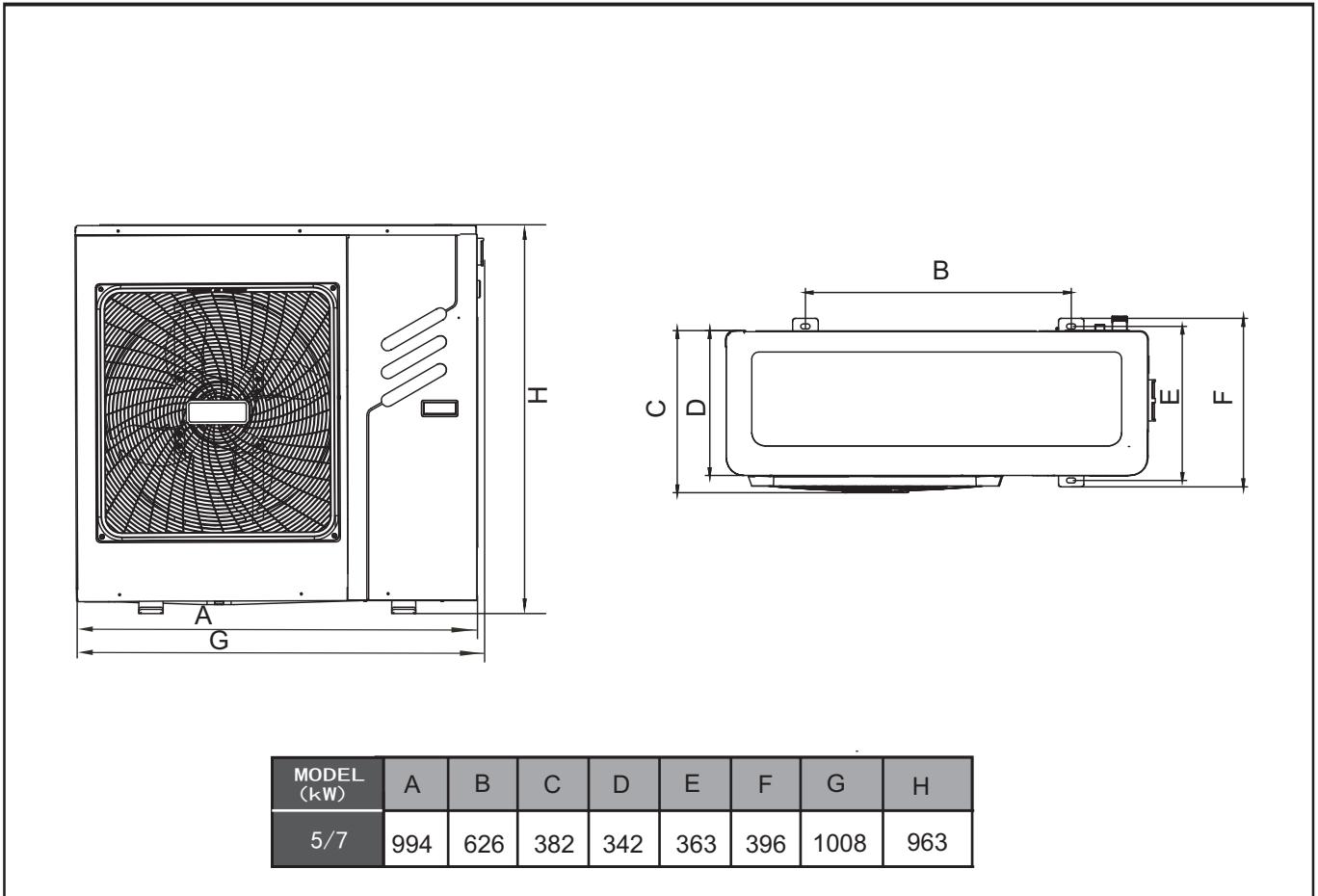

INSTALLATION

CHOICE OF INSTALLATION SITE

Before installing the unit, agree with the customer the site where it will be installed, taking the following points into consideration:

- check that the fixing points are adequate to support the weight of the unit;
- payscrupulous respect to safety distances between the unit and other equipment or structures to ensure that air entering the unit and discharged by the fans is free to circulate.

POSITIONING

Before handling the unit, check the capacity of the lifting equipment used, respecting the instructions on the packaging.

To move the unit in the horizontal, make appropriate use of a lift truck or similar, bearing in mind the weight distribution of the unit. To lift the unit, insert tubes long enough to allow positioning of the lifting slings and safety pins in the feet on the unit.

To avoid the slings damaging the unit, place protection between the slings and the unit. Position the unit in the site indicated by the customer. Place either a layer of rubber (min. thickness 10 mm) or vibration damper feet (optional) between the base and support surface. Fix the unit, making sure it is level and that there is easy access to hydraulic and electrical components. If the site of installation is exposed to strong winds, fix the unit adequately to the support surface using tie rods if necessary. If a heat pump unit is being installed, make sure the condensate is drained using the drain hose supplied as standard. Prevent leaves, branches or snow from accumulating around the unit. These could reduce the efficiency of the unit.

INSTALLATION SPACE

- Since the gravity center of the unit is not at its physical center, so please be careful when lifting it with a sling.
- Never hold the inlet of the outdoor unit to prevent it from deforming.
- Do not touch the fan with hands or other objects.
- Do not lean it more than 45°, and do not lay it sidelong.
- Make concrete foundation according to the specifications of the outdoor units.
- Fasten the feet of this unit with bolts firmly to prevent it from collapsing in case of earthquake or strong wind.

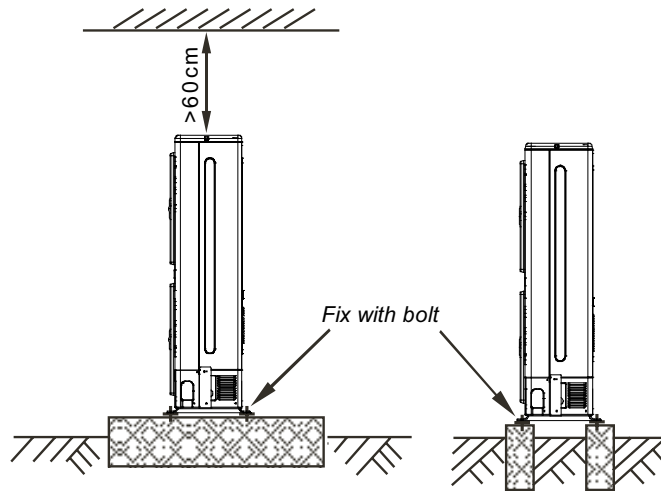

Single unit installation

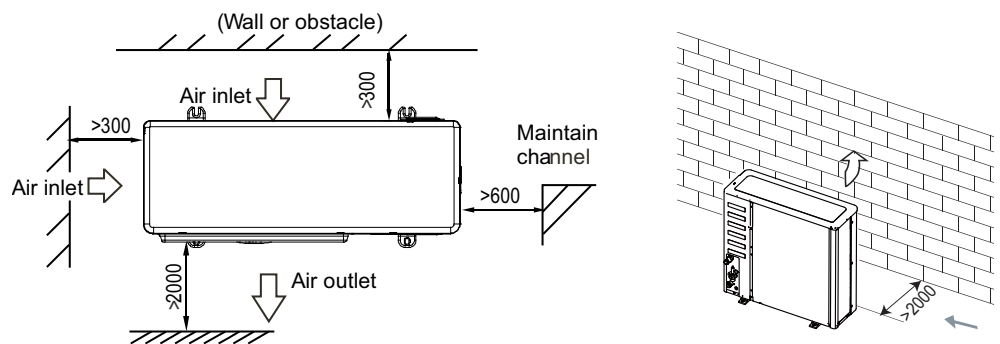

Parallel connect two units or above

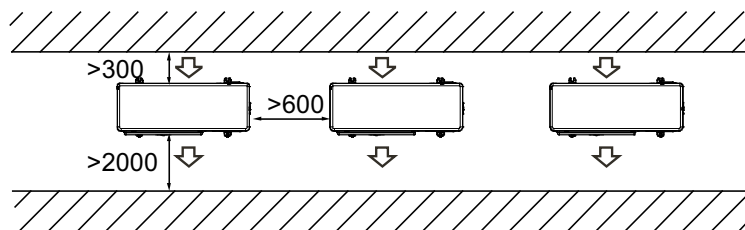

Parallel connect the front with rear sides

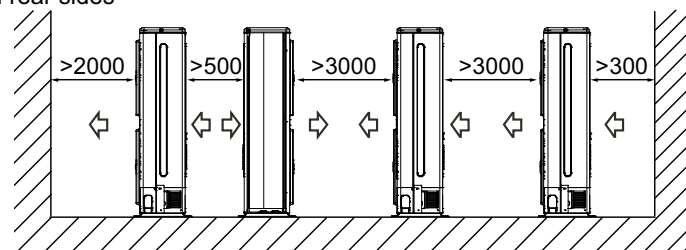

All the pictures in this manual are for explanation purpose only. They may be slightly different from the air conditioner you purchased (depend on model).The actual shape shall prevail.

The choice and installation of components is the responsibility of the installer who should follow good working practice and current legislation. Before connecting the pipes, make sure they do not contain stones, sand, rust, dross or other foreign bodies which might damage the unit. Construction of a bypass is recommended to enable the pipes to be washed through without having to disconnect the unit (see drain valves). The connection piping should be supported in such a way as to avoid it weighing on the unit. It is recommended that the following devices are installed in the water circuit of the evaporator. A hydraulic safety valve shall be mounted in water system, which should open constantly.

1. Two pressure gauges with a suitable scale (inlet and outlet).
2. Two vibration damper joints (inlet and outlet).
3. Two gate valves (normal in inlet and calibrating in outlet).
4. A flow switch (inlet) or a differential pressure switch (inlet-outlet).
5. Two thermometers (inlet and outlet).
6. An inlet filter as close as possible to the evaporator and positioned to allow easy access for routine maintenance.
7. An energy-saving water tank.
8. Additional pump.
9. The connecting line of flow switch, which mounted outside the unit, should be connected in series with the pressure-difference switch, which mounted inside the unit.

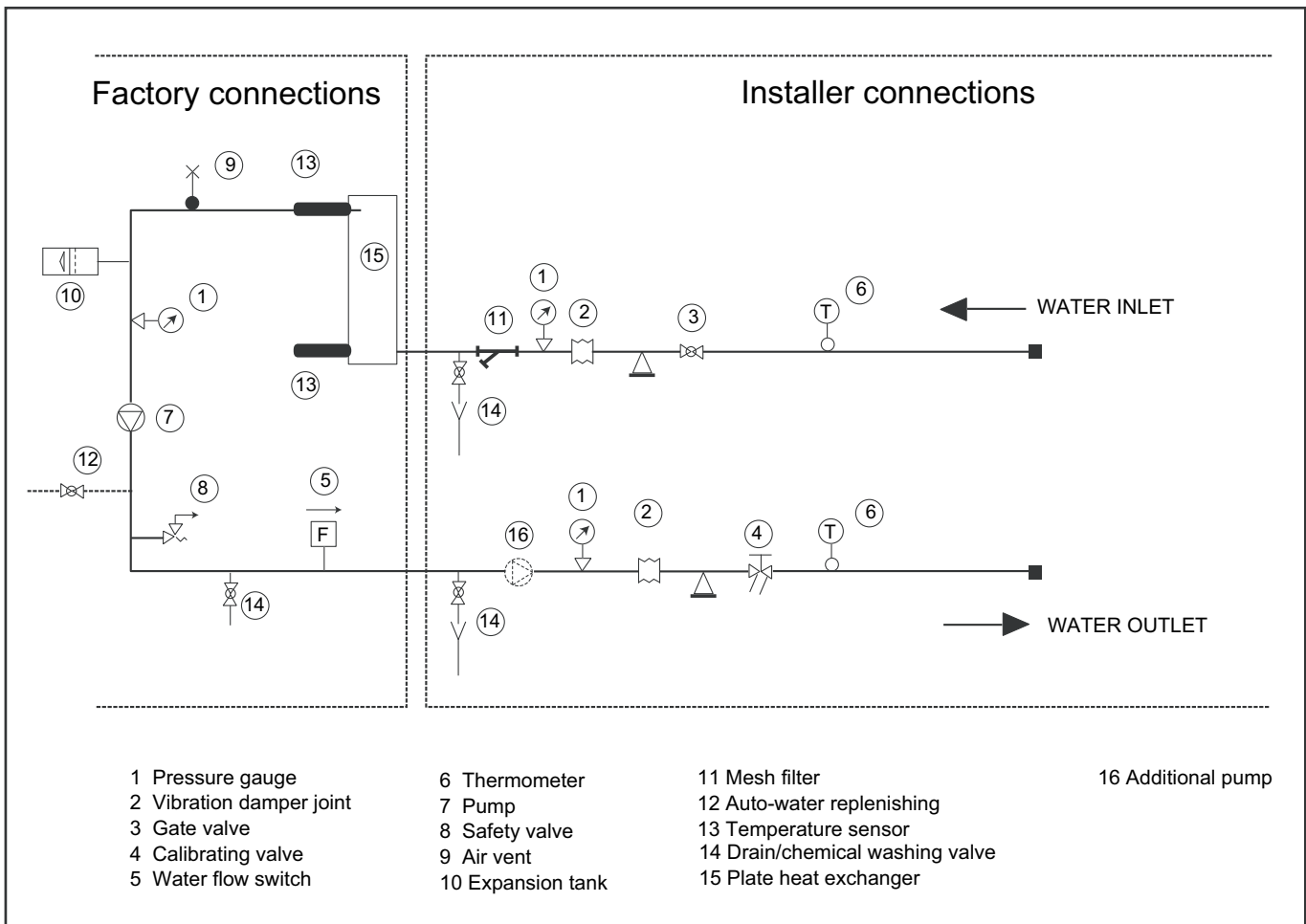

If the installation requires a useful head higher than that obtained by installing a pump assembly and storage tank, it is recommended that an additional pump is installed on the unit. Provided the additional pump installed inside of unit (only model 12/14/16KW can be installed inside of unit), the pump must be connected close to plate heat exchanger. Provided the pump installed outside of unit, the pump shall be connected at water pipe's outlet. The pump can be easily installed on the unit by removing the pump connection pipe (see page 3). Connect to terminal PL, PN on the electrical panel.

⚠ The chillers must be provided with a filling/top-up system connected to the return line and a drain cock in the lowest part of the installation. Installations containing anti-freeze or covered by specific legislation must be fitted with hydraulic disconnectors.

⚠ The manufacturer is not liable for obstruction, breakage or noise resulting from the failure to install filters or vibration dampers. Particular types of water used for filling or topping up must be treated with appropriate treatment systems. For reference values, see the table.

EMPTYING THE INSTALLATION

- Before emptying, place the mains switch in the "off" position
- Make sure the installation fill/top-up water cock is closed
- Open the drain cock outside the unit and all the installation and terminal air vent valves.

SIZE AND POSITION OF CONNECTIONS

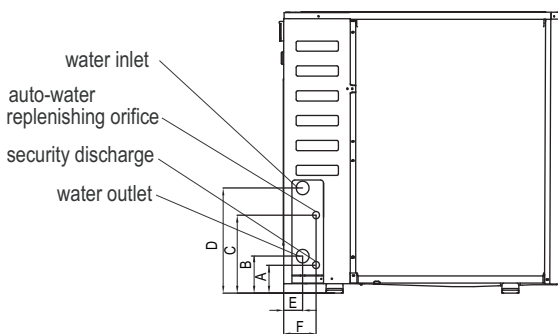

A (mm)	95	95
B (mm)	126	126
C (mm)	250	250
D (mm)	360	360
E (mm)	68	68
F (mm)	114	114
Water inlet/outlet (Ø)	R1	R1
Auto-water replenishing (Ø)	G1/2	G1/2
Security discharge (Ø)	G1/2	G1/2

FILLING THE INSTALLATION

- Before filling, check that the installation drain cock is closed.
- Open all installation and terminal air vents.
- Open the gate valves.
- Begin filling, slowly opening the water filling cock outside the unit.
- When water begins to leak out of the terminal air vent valves, close them and continue filling until the pressure gauge indicates a pressure of 1.5 bars.

⚠ The installation must be filled to a pressure of between 1 and 2 bars. It is recommended that this operation be repeated after the unit has been operating for a number of hours. The pressure of the installation should be checked regularly and if it drops below 1 bar, the water content should be topped-up. Check the hydraulic tightness of joints.

⚠ An all-pole disconnection device which has at least 3mm separation distance in all pole and a residual current device (RCD) with the rating of above 10mA shall be incorporated in the fixed wiring according to the national rule the appliance shall be installed in accordance with national wiring regulations.

⚠ If the fluid in the circuit contains anti-freeze, it should not be allowed to drain freely as it is pollutant. It should be collected for possible reuse. When draining after heat pump operation, take care as the water may be hot (up to 50°).

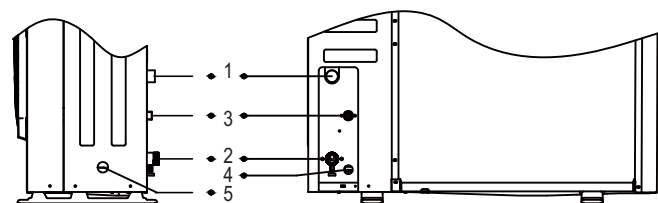

- | | |
|---|---------------------------------|
| 1 | Water inlet (1") |
| 2 | Water outlet (1") |
| 3 | Auto-water replenishing orifice |
| 4 | Water outlet of safety Valve |
| 5 | Wire hole |

DESIGN OF THE STORE TANK IN THE SYSTEM

- kW is the unit for cooling capacity, L is the unit for (G) minimum water flow volume in the formula.
Comfortable type air conditioner
G= cooling capacity×2.6L
Process type cooling
G= cooling capacity×7.4L

- In certain occasion (especially in manufacture cooling process), for conforming the system water content requirement, it's necessary to mount a tank equipping with a cut-off baffle at the system to avoid water short-circuit, Please see the following schemes:

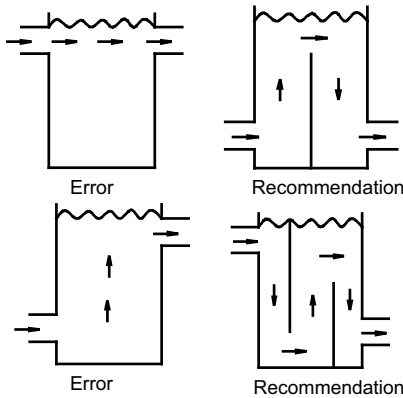

CHILLER WATER FLOW

Minimum chilled water flow

The minimum chilled water flow is shown in the below table. If the system flow is less than the minimum unit flow rate the evaporator flow can be recalculated, as shown in the diagram.

For minimum chilled water flow rate

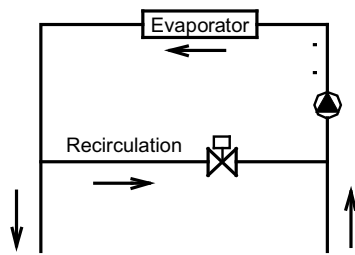

Maximum chilled water flow

The maximum chilled water flow is limited by the permitted pressure drop in the evaporator. It is provided in the below table.

If the system flow is more than the maximum unit flow rate, bypass the evaporator as shown in the diagram to obtain a lower evaporator flow rate.

For maximum chilled water flow rate

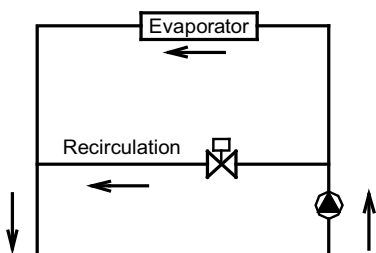

Minimum and maximum water flow rates

Item	Water flow rate(m ³ /h)	
	Minimum	Maximum
5kW	0,77	0,95
7kW	1,08	1,54

WATER QUALITY CONTROL

When industrial water is used as chilled water, little furring may occur; however, well water or river water, used as chilled water, may cause much sediment, such as furring, sand, and so on. Therefore, well water or river must be filtered and softening water equipment before flowing into chilled water system. If sand and clay settle in the evaporator, circulation of chilled water may be blocked, and thus leading to freezing accidents; if hardness of chilled water is too high, furring may occur easily, and the devices may be corroded. Therefore, the quality of chilled water should be analyzed before being used, such as PH value, conductivity, concentration of chloride ion, concentration of sulfide ion, and so on.

PH	6 - 8
Total hardness	less than 50 ppm
Electrical conductivity	less than 200 mV/cm (25C)
Sulfide ion	none
Chlorine ion	less than 50 ppm
Ammonia ion	none
Sulfate ion	less than 50 ppm
Silicon	less than 30 ppm
Total iron	less than 0.3 ppm
Sodium ion	No requirement
Calcium ion	less than 50 ppm

FILLING THE INSTALLATION

- Before filling, check that the installation drain cock is closed.
- Open all installation and terminal air vents.
- Open the gate valves.
- Begin filling, slowly opening the water filling cock outside the unit.
- When water begins to leak out of the terminal air vent valves, close pressure gauge indicates a pressure of 1.5 bars.

EMPTYING THE INSTALLATION

- Before emptying, place the mains switch in the “off” position.
- Make sure the installation fill/top-up water cock is closed.
- Open the drain cock outside the unit and all the installation and terminal air vent valves.

The unitary minichillers leave the factory already wired, and require the installation of an omnipolar thermal overload switch, a lockable mains disconnecting switch for the connection to the mains power supply, and the connection of the flow switch to the corresponding terminals. All the above operations must be carried out by qualified personnel in compliance with the legislation in force.

For all electrical work, refer to the electrical wiring diagrams in this manual. You are also recommended to check:

-that the characteristics of the mains electricity supply are adequate for the absorptions indicated in the electrical characteristics table below, also bearing in mind the possible use of other equipment at the same time.

 Power to the unit must be turned on only after installation work (hydraulic and electrical) has been completed.

All electrical connections must be carried out by qualified personnel in accordance with legislation in force in the country concerned.

Respect instructions for connecting phase, neutral and earth conductors. The power line should be fitted upstream with a suitable device to protect against short-circuits and leakage to earth, isolating the installation from other equipment.

ELECTRICAL PANEL

The electrical panel is located inside the unit at the top of the technical compartment where the various components of the refrigerant circuit are also to be found.

To access the electrical panel, remove the front panel of the unit by undoing the screws.

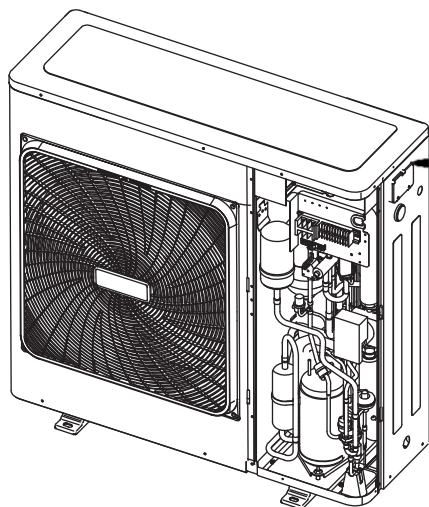

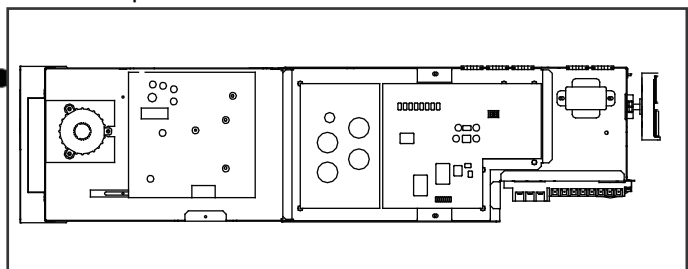

Electrical panel



 Voltage must be within a tolerance of $\pm 10\%$ of the rated power supply voltage for the unit (for three phase units, the unbalance between the phases must not exceed 3%). If these parameters are not respected, contact the electricity supply company. For electrical connections, use double insulation cable in conformity with current legislation in the country concerned

An omnipolar thermal overload switch and a lockable mains disconnecting switch, in compliance with the CEI-EN standards (contact opening of at least 3mm), with adequate switching and residual current protection capacity based on the electrical data table shown below, must be installed as near as possible to the appliance

 The devices on the unit must be lockable. An efficient earth connection is obligatory. Failure to earth the appliance absolves the manufacturer of all liability for damage. In the case of three phase units, ensure the phases are connected correctly.

 Do not use water pipes to earth the unit.



ELECTRICAL POWER CONNECTIONS

The Specification of Power

MODEL		MUENR-05-H6	MUENR-07-H6
POWER	PHASE	1-PHASE	1-PHASE
	FREQUENCY AND VOLT	220-240V~, 50Hz	220-240V~, 50Hz
CIRCUIT BREAKER/FUSE (A)		30/25	30/25
POWER WIRING(mm ²)		3x4	3x4
GROUND WIRING(mm ²)		4	4

⚠ The power cord type designation is H07RN-F.

The means for disconnection from a power supply shall be incorporated in the fixed wiring and have an air gap contact separation of at least 3mm in each active(phase) conductors.

For the functional connection of the unit,bring the power supply cable to the electrical panel inside the unit and connect it to terminals L-N and  respecting the (L) phase, (N) neutral and  earth in the case of single phase units (220-240V~50Hz),or L1-L2-L3 phases,N neutral and PE earth in three phase units (380-415V 3N~ 50Hz).

Dealer provides power cord.

Customer connection terminal

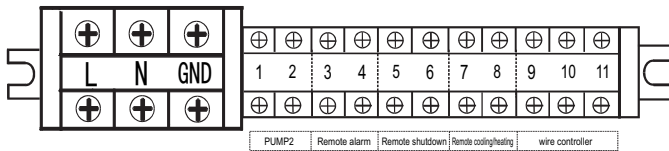

Electrical power connections

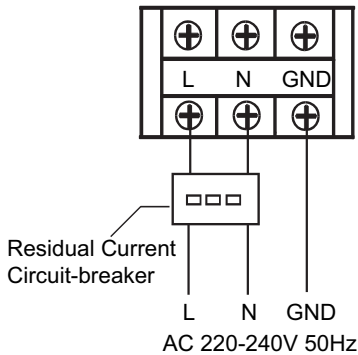

NOTE:

The outdoor units must be installed with an Residual Current Circuit-breaker near the power supply and must be effectively earthed.

Auxiliary function connections

■ Additional pump

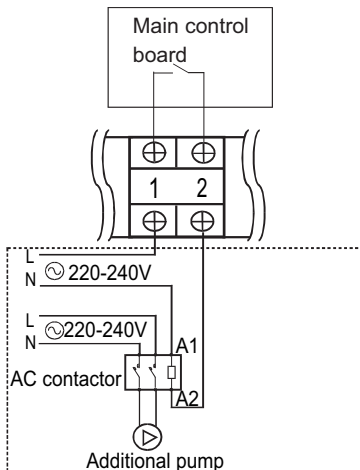

“PUMP2” terminal only provides passive switching signal. Additional water pump must be controlled by the AC contactor.

■ Remote shutdown (ON/OFF)

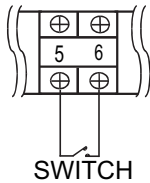

If switch is closed, the unit will be stopped forcibly.
Under this circumstance, anti-frozen protection and other protection functions are still effective.
If switch breaks, unit can run normally according settings.

■ Remote cooling/heating

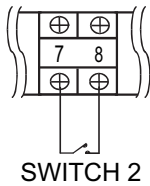

If switch2 is closed, the unit will shift to heating mode forcibly;
If switch2 breaks, the unit will shift to cooling mode forcibly.

! Remote shutdown and Remote cooling/heating is optional function.
Choose this function by DIP switch SW4_1 on PCB board. Factory default has no remote cooling/heating.

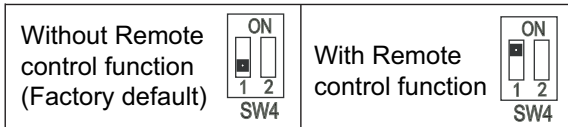

When the remote control and wire controller used at the same time, the unit will carry out the last command of arbitrary terminal.
Remote shutdown has the highest priority. In the status of remote shutdown, other controllers can't start the unit.

■ Wire controller KJR-120F1/BMK-E (optional CL92340)

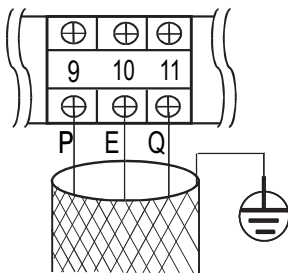

The wire controller is optional.
Please use 3-core shielded wire to connect the wire controller and the shielding layer must be grounded.
When connecting wire controller, host unit control panel is mainly used for display which can carry out parameter inquiry such as inquiry and checking, and can't be used to set mode and temperature.

■ Remote alarm

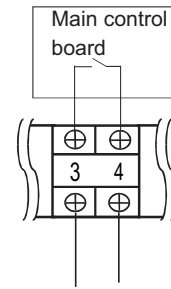

“Remote alarm” terminal only provides passive switching signal.
Current passing through the terminal interface should less than 1.5A,
otherwise please use AC contactor to control load indirectly.

WIRING DIAGRAM

MUENR-05/07-H6

202090490086

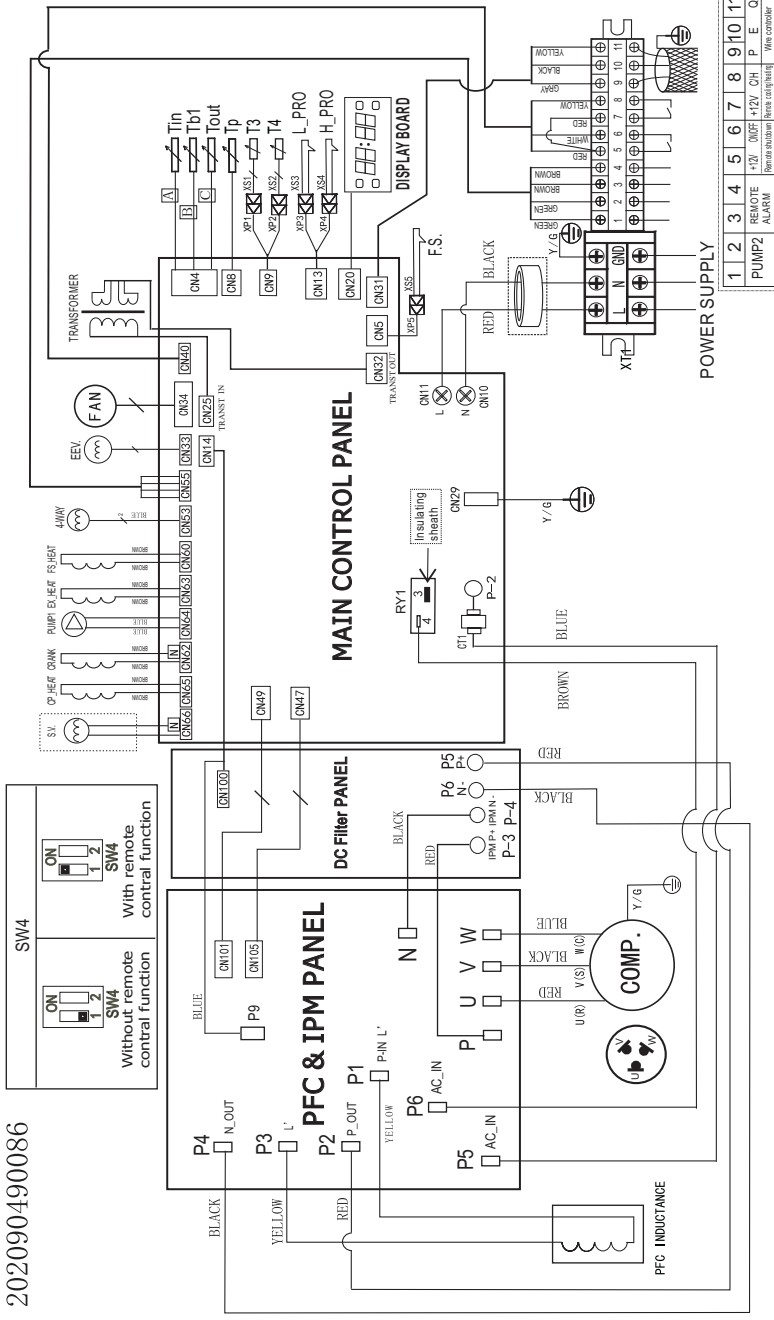

CODE	PART NAME
COMP.	Compressor
CT1	AC current detector
EEV	Electric Expansive Valve
FAN	Outdoor fan motor
CRANK	Compressor electric heating zone
CP_HEAT	Plate Heat Exchanger electric heating zone
FS_HEAT	Flow switch electric heating zone
EX_HEAT	Exhaust valve electric heating zone
H-PRO	High pressure switch
L-PRO	Low pressure switch
4-WAY	4-Way valve
T3	Condenser temperature sensor
T4	Outdoor ambient temperature sensor
TP	Comp. Discharge temperature sensor
Tb1	Plate heat exchanger anti-freezing temperature sensor
Tin	Inlet water temperature sensor of heat exchanger
Tout	Outlet water temperature sensor of heat exchanger
XT1	14-Way terminal
F.S.	Flow switch

NOTE • The wire controller is optional. Please use 3-core shielded wire to connect the wire controller and the shielding layer must be grounded.

- "PUMP2" and "REMOTE ALARM" wiring terminal ports provide only the switch signal. The load should be controlled through the AC contactor.

Checking No.	Meanings
11	Tout temp. Value
12	Tb1 temp. Value
13	Tb2 temp. Value (Reserved)
14	T6 temp. Value (Reserved)
15	Outdoor units current
16	Power supply voltage AD value
17	EXV opening
18	Error 1
19	Error 2
20	Error 3
Temp. Sensor code	
Tin/Tout/Tb1/Tb2/T4	Property values
TP	B ₂₅₅₀ =4100K, R ₂₅ °C=10kΩ B ₂₅₅₀ =3950K, R ₉₀ °C=5kΩ

Checking No.	Meanings
0	The normal display
1	Frequency
2	Running mode 0-Shutdown, 1-The pump model, 2-Cooling, 3-Heating, 4-Forced cooling.
3	Fan speed 0-Shutdown, 1~7-Fan speed
4	Total capacity requirements
5	The revised capacity requirements
6	Cooling/heating temp. set
7	T3 temp. Value
8	T4 temp. Value
9	TP temp. Value
10	Tin temp. Value

Display	Malfunction or Protection
GL	High inlet and outlet water temp. difference protection in cooling mode
CP	Plate Heat Exchanger anti-freezing protection
PL	Radiator high temperature protection
P1	High pressure protection
P2	Low pressure protection
P3	Outdoor units current protection
P4	Compressor discharge temp. Protection
P5	Condenser high temperature protection
P6	IPM mode protection
Pb	Outdoor units anti-freezing protection
PH	High temperature protection in heating mode
HH	Tin temperature sensor malfunction
dF	Defrosting
d8	Remote control

Display	Malfunction or Protection
E4	T3&T4 temperature sensor malfunction
E5	Voltage protection
E6	DC fan motor malfunction
E9	EEPROM malfunction
EA	5-minute error for heating mode fan in area A
Eb	Two times of E6 protection in 10 minutes
EC	Tout temperature sensor malfunction
C0	Tb1 temperature sensor malfunction
C1	Tb2 temperature sensor malfunction
C8	Flow switch malfunction
CH	Low water temperature protection in cooling mode
P8	Typhoon protection
H0	Communication malfunction between the main controlling chip and IPDU

Air conditioner operating conditions

For proper performance, run the air conditioner under the following temperature conditions

Cooling operation	Outdoor temperature: -5°C~46°C
	Water outlet temperature: 4°C~20°C
Heating operation	Outdoor temperature: -15°C~27°C
	Water outlet temperature: 30°C~54°C

If air conditioner is used beyond the above conditions, safely protection features may come into operation

Note: When the outdoor temperature is too low, the unit in standby mode will activate frost protection, forced to run pumps or forced heating operation to protect the unit water system.

If air conditioner is used beyond the above conditions, safely protection features may come into operation

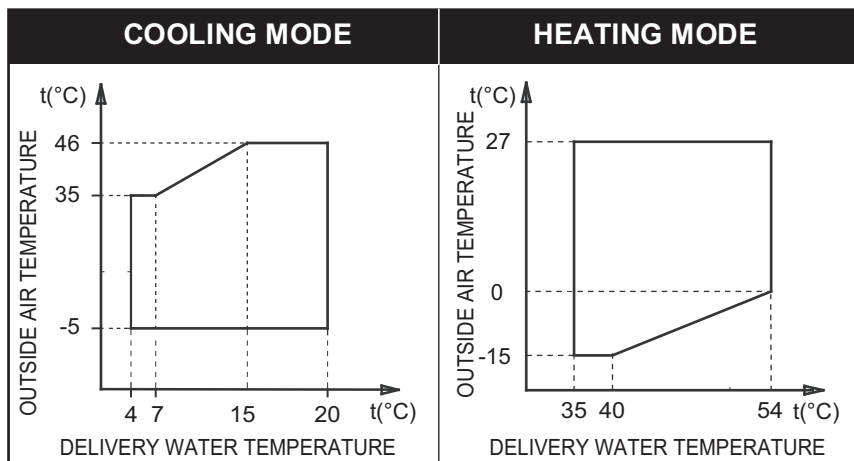

Thermal head min.- max.	4-6
Water circuit pressure (bars)	1-3
Max.storage temperature	55

Water and glycol solutions used as a thermal vector in the place of water reduce the performance of the unit. Multiply the performance figures by the values given in the following table.

ETHYLENE GLYCOL

Quality of glycol/%	Modification coefficient				Freezing point/°C
	Cooling capacity modification	Power modification	Water resistance	Water flow modification	
0	1.000	1.000	1.000	1.000	0.000
10	0.984	0.998	1.118	1.019	-4.000
20	0.973	0.995	1.268	1.051	-9.000
30	0.965	0.992	1.482	1.092	-16.000
40	0.960	0.989	1.791	1.145	-23.000
50	0.950	0.983	2.100	1.200	-37.000

PROPYLENE GLYCOL

Quality of glycol/%	Modification coefficient				Freezing point/°C
	Cooling capacity modification	Power modification	Water resistance	Water flow modification	
0	1.000	1.000	1.000	1.000	0.000
10	0.976	0.996	1.071	1.000	-3.000
20	0.961	0.992	1.189	1.016	-7.000
30	0.948	0.988	1.380	1.034	-13.000
40	0.938	0.984	1.728	1.078	-22.000
50	0.925	0.975	2.150	1.125	-35.000

If no glycol is added, the water must be drained out when there is a power failure.

Fouling factors (m ² °C/W)	Evaporator		
	f1	fk1	fx1
4.4 x 10 ⁻⁵	-	-	-
0.86 x 10 ⁻⁴	0.96	0.99	0.99
1.72 x 10 ⁻⁴	0.93	0.98	0.98

- f1 capacity correction factor
- fk1 compressor power input correction factor
- fx1 total power input correction factor



During winter leaving the unit unused, please drain water out completely from unit if no antifreeze were charged into pipeline, or keep power on (at standby or off status) and ensure that water is contained inside of unit.

When ambient temperature lower 5 running cooling mode must be charged antifreeze. Refer to upper parameters for the charged volume.

FOULING FACTORS

The performance data given refer to conditions with clean evaporator plates (fouling factor=1). For different fouling factors, multiply the figures in the performance tables by the coefficient given in the following table.

If the total water volume in the system is less than the value in the table above, the additional water tank is necessary in order to avoid the compressor On and Off frequently.

The minimum size of the water tank is calculated as:
 Size of additional water tank(L) = Minimum water volume(L) - Actual water volume(L)

USEFUL PUMP HEAD CURVES (10 to 16 kW)

Constant speed I,II,III

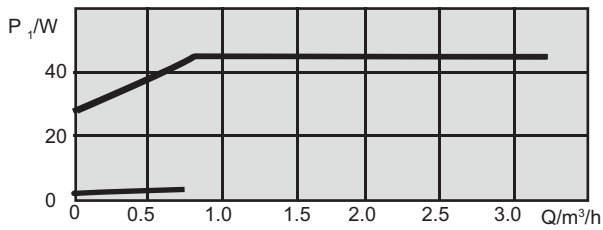
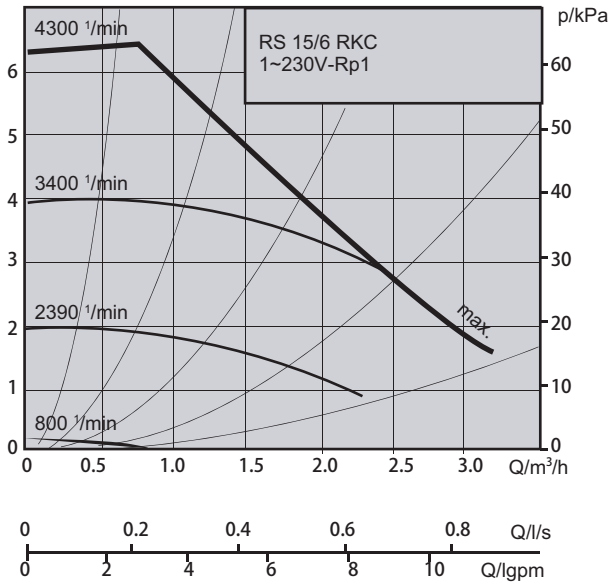

(*) To obtain the useful head of the installation, subtract the pressure drop of the plate heat exchanger.



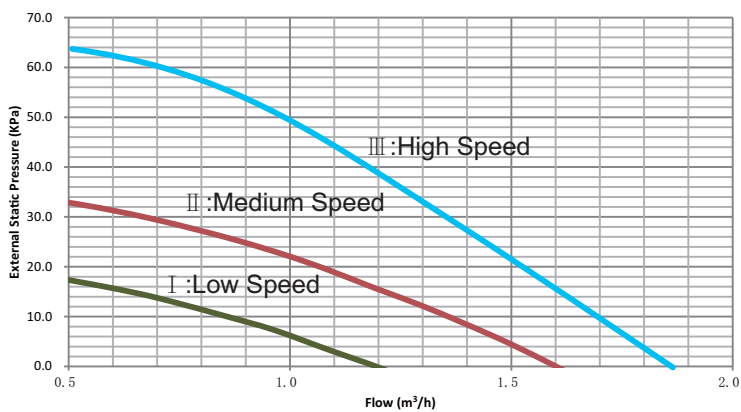

HEAT EXCHANGER PRESSURE DROP (WATER SIDE)

MUENR-05/07-H6



PUMP LED DIAGNOSIS AND SOLUTIONS

The pump has an LED operating status display. This makes it easy for the technician to search for the cause of a fault in the heating system.

LED COLOUR	MEANING	DIAGNOSTIC	CAUSE	REMEDY
Continuos green 	Normal Runing	Pump runs as expected	Normal operation	
Quick green blinks 	Venting routine running	Pump runs during 10 min in venting function. Afterwards the installer has to adjust the targeted performance		
Red/green blinking 	Abnormal situation (pump functional but stopped)	Pump will restart by itself after the abnormal situation disappeared	1. Undervoltage or Overvoltage: $U < 160V$ or $U > 280V$ 2. Module overheating: T° inside motor too high	1. Check voltage: $160V < U < 280V$ 2. Check water and ambient T°
Red blinking 	Stopped (e.g. pump blocked)	Reset the pump. Check the LED signal	Pump can not restart itself due to a permanent failure	Change pump
No LED	No power supply	No voltage on electronics	1. Pump is not connected to power supply. 2. LED is damaged. 3. Electronics are damaged	1. Check cable connection. 2. Check if pump is running 3. Change pump

1. Connect the water supply to the fill valve and open the valve.
2. Make sure the automatic air purge valve is open (at least 2 turns).
3. Fill with water until the manometer indicates a pressure of approximately 2.0 bar. Remove air in the circuit as much as possible using the air purge valves. Air present in the water circuit might cause malfunctioning of the backup heater.

Do not fasten plastic cover on the air purge valve at the top side of the unit when the system is running. Open air purge valve, turn anticlockwise at least 2 full turns to release air from the system.

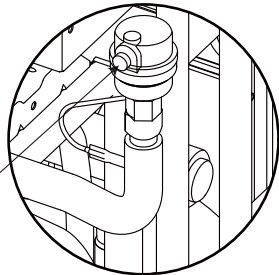

NOTE

During filling, it might not be possible to remove all air in the system. Remaining air will be removed through the automatic air purge valves during the first operating hours of the system. Topping up the water afterwards might be required.

- The water pressure indicated on the manometer will vary depending on the water temperature (higher pressure at higher water temperature). However, at all times water pressure should remain above 0.3 bar to avoid air entering the circuit.
- The unit might drain-off too much water through the pressure relief valve.
- Water quality must be according to "Safe Drinking water Act"

FAILURE DIAGNOSIS AT THE MOMENT OF FIRST INSTALLATION

- If nothing is displayed on the user interface, it is necessary to check for any of the following abnormalities before diagnosing possible error codes.
 - Disconnection or wiring error (between power supply and unit and between unit and user interface).
 - The fuse on the PCB may have blown.
- If the user interface shows "E8" as an error code, there is a possibility that there is air in the system, or the water level in the system is less than the required minimum.
- If the error code E2 is displayed on the user interface, check the wiring between the user interface and unit.

REFRIGERANT CIRCUIT

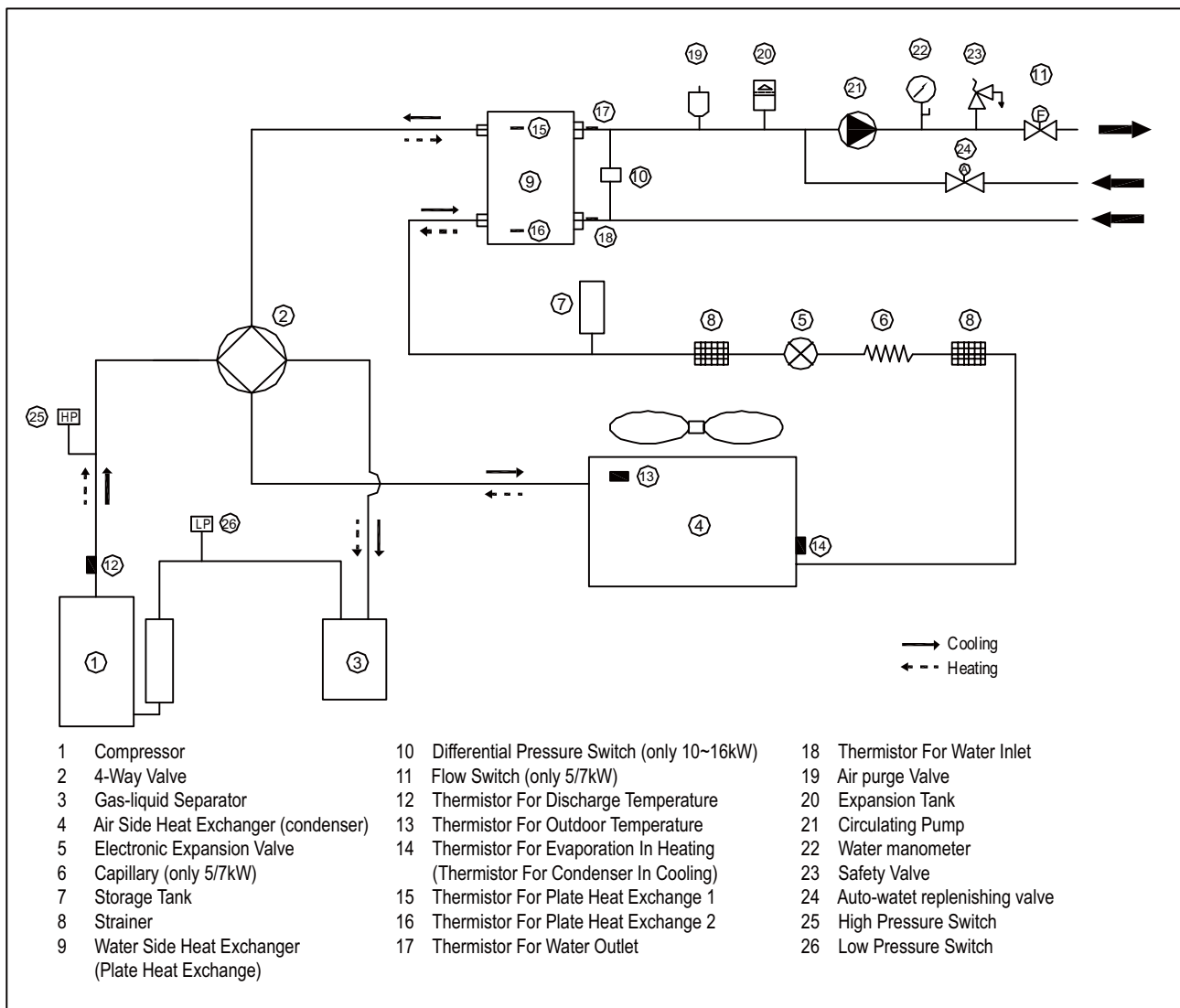

PREPARING FOR FIRST START UP

Restarting after shutting down for long periods

The chiller must be started up for the first time by the Technical Service. Before starting up the chillers, make sure that:

- All safety conditions have been respected
 - The chiller is adequately fixed to the surface it rests on
 - Functional distances have been respected;
 - Hydraulic connections have been carried out as indicated in the instruction manual
 - The water circuit is filled and vented. When draining after heat pump operation, take care as the water may be hot;
 - The water circuit valves are open
 - Electrical connections have been carried out correctly
 - Voltage is within a tolerance of 10% of the rated voltage for the unit
 - The unit is correctly earthed
 - All electrical and hydraulic connections are tight and have been completed correctly.
- Use grommet A for the electrical power cable and grommet B for the other external wires.

To complete the electrical connections:

- Remove the inspection panel by unscrewing the five screws

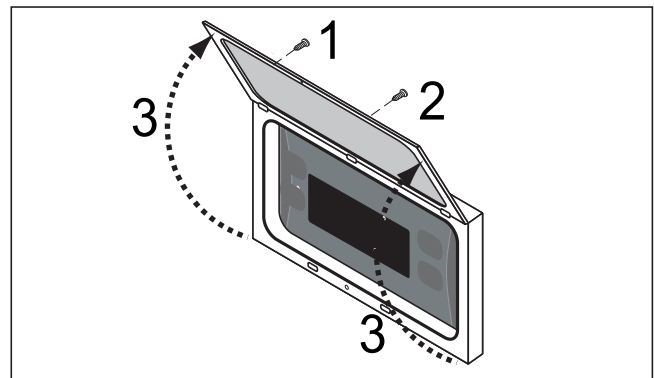
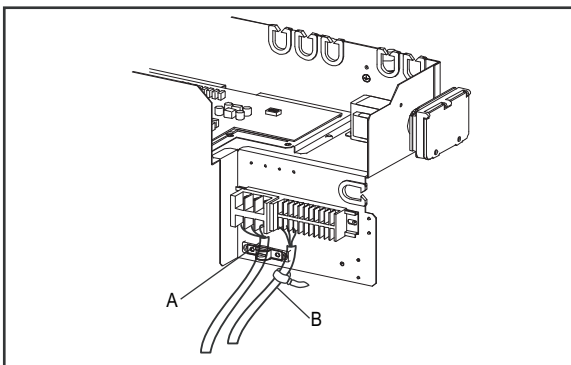
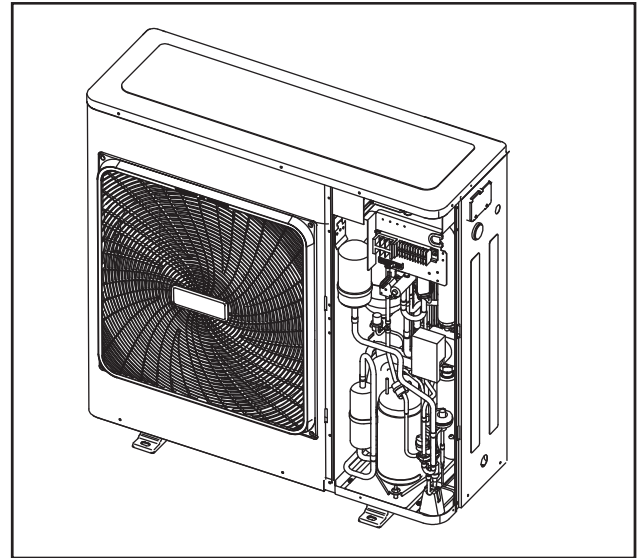

To access the control panel, open the door:

- remove the screw 1 and screw 2;
- lift the door 3.









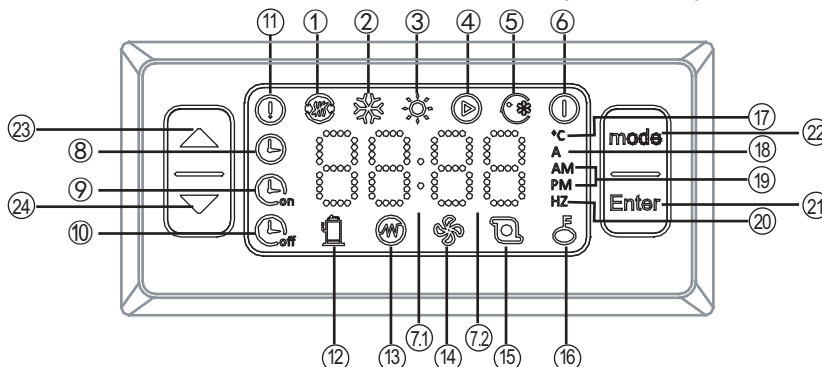









ACTIVATING AND DEACTIVATING THE UNIT



U I A

I. Icon Description

The front panel of the device functions as the user interface and is used to perform all operations relating to the device.



NO.	Icon	Description
①		Outside heat source running icon (Reserved)
②		Cooling mode icon This icon will be constantly light when customers choose cooling mode.
③		Heating mode icon This icon will be constantly light when customers choose heating mode.
④		Water pump mode icon This icon will be constantly light when customers choose water pump mode.
⑤		Force cooling icon This icon will be constantly light when customers choose force cooling mode.
⑥		Power off icon This icon will be constantly light when customers choose Power off mode.
⑦	88:88	Clock icon, the middle ":" flicker once every 1s. It will display time when customers set the timer.
⑦	88	The last 2 digits of the nixie tube "88" icon. If "88" is constantly light, it will display the current inlet water temperature. Its unit is °C . When customers do water temperature set, icon will display the set water temperature. When checking, "88" will display the result of checking. When water heating is broken down or in protection, "88" display the error code and protection code.
⑧		Clock icon It will display when finish setting the clock and be extinguished when the clock setting work is done.
⑨		Timing on function icon  will flicker when setting timing on. The icon will be constantly light when finish setting.
⑩		Timing off function icon  will flicker when setting timing off. The icon will be constantly light when finish setting.
⑪		Breakdown light icon When the unit is broken down or under protection, this icon will flicker and will be extinguished when malfunction and protection are eliminated.
⑫		Compressor booting indicator icon When booting the compressor, this icon will be constantly light. It will be extinguished when the compressor is shut down
⑬		E-heater booting indicator icon (Reserved) When booting the external E-heater, this icon will be constantly light. It will be extinguished when the external E-heater is shut down.
⑭		Fan booting indicator icon When booting the fan, this icon will be constantly light. It will be extinguished when the fan is shut down.
⑮		Water pump booting indicator icon When booting the water pump, this icon will be constantly light. It will be extinguished when the water pump is shut down.
⑯		Auto-lock (unlock) function icon If don't operate the controller in 60s, the keyboard will lock automatically. Press "mode" and "Enter" simultaneously for 3s to unlock.
⑰		Temperature unit icon When the control panel displays temperature, this icon will be constantly light.
⑱		Current unit icon When the control panel displays current, this icon will be constantly light.
⑲	AM PM	Time format icon The unit is 12-hour format. "AM" will be constantly light when it is forenoon. "PM" will be constantly light when it is afternoon
⑳	HZ	Frequency unit icon It will be constantly light when the control panel displays frequency of the compressor.
㉑	Enter	ON/OFF and OK button 1.Long press "Enter" for 3S will power on or off the controller. 2.Press "Enter" to confirm the former operation when finishing the setting work.
㉒	mode	Mode choice function/Function choice/Back function button 1.Mode choice function. Choose operation mode. 2.Function choice. Long press it for 3s to enter function setting in the main interface.(Clock setting, Timing on and timing off setting) 3.Back to the previous menu. Long press it for 3s to back to previous menu in the function setting interface. Top menu is the main interface.

NO.	Icon	Description
②③		Up 1.(Value increase) 2.Forward to the previous interface.
②④		Down 1.(Value decrease) 2.Backward to the next interface.

II.Control panel operation description



1) ON/OFF

Operation mode one:

Power off: Long press “**Enter**” for 3s in the main interface. The panel displays “OFF” and other icons will be extinguished. The unit stops.



Power on: When the display panel shows “OFF”, long press “**Enter**” for 3s and wait for the unit to enter standby mode. Then power on the unit according to Operation mode two.

Operation mode 2:



Power off: Press “**mode**” in the main interface to enter mode choice function and the icon which indicate the current mode will flicker. Press “**mode**” circularly to choose power off mode, “” will flicker at this moment. Press “**Enter**” button to confirm the power off mode. By this time, “” will be constantly light and the unit stops.

Power on: In the power off mode, press “**mode**” to enter mode choice function. Press “**mode**” circularly to choose one kind of “power on” mode, the mode icon will flicker at the moment. Press “**Enter**” to confirm the power on mode. The unit will run as the chosen mode when the mode icon will be constantly light.

2) Mode choice and temperature settings





Press “**mode**” in the main interface to enter mode choice function. The “Mode” icon will flicker. Click “**mode**” circularly to choose a mode. The circulating order is “Cooling mode”→“Heating mode”→“Water pump mode”→“Power off mode”→“Cooling mode”. The chosen mode will flicker. Press “” or “” to increase/decrease the temperature in the chosen mode.

Press “**Enter**” to confirm power off mode and the set temperature. Mode icon will be constantly light and the unit will run as the chosen mode.

Press “” or “” in the main interface to increase/decrease the temperature in the chosen mode.



3) Clock setting

Long press “**mode**” for 3s to enter function interface.

“” clock icon will flicker. Press “**Enter**” to enter clock setting function. “” icon will be constantly light and the first 2 digits on nixie tube will flicker. Press “” or “” to set minute. Press “**Enter**” when finish setting and “” will be extinguished.

4) Timing setting



1. Timing on setting





① Long press “**mode**” for 3s to enter function interface. “” clock icon will flicker. Press “**mode**” again to enter timing on function. “” will flicker and press

“**Enter**” to enter timing on setting.



② At this moment, last 2 digits of the nixie tube display “01” which means the first group setting begins. Press “**Enter**” to the next step.

③ By this time, mode icon will flicker and press “**mode**” to choose timing on mode. Press “**Enter**” to confirm your choice and go to the next step.

④ By this time, the last 2 digits of the nixie tube will flicker and press “” or “” to adjust temperature and set the temperature of the inlet water. Press “**Enter**” to confirm and move to the next step.

⑤ By this time, the first 2 digits of the nixie tube will flicker and press “” or “” to adjust time of timing on. Press “**mode**” to confirm and switch to minute setting automatically. The last 2 digits of the nixie tube will flicker and press “” or “” to adjust minute setting of timing on.(minimal unit of minute adjustment: 15 minutes) .

⑥ Press “**Enter**” to confirm. The first group setting is finished and “” will be constantly light.



When processing the second timing setting, repeat the 1-2 operation above. When the nixie tube displays “01” and flicker, press “” or “” to choose the timing on group. When the nixie tube displays “02” which means setting timing on function of the second group. Refers the timing on setting operation of group 1 to set that of group 2.



- Long press “**mode**” for 3s to return to the previous interface to reset the parameter during setting clock timing.



2.Timing off setting

① Long press “**mode**” for 3s in the main interface to enter function interface. Press “**mode**” circularly to enter timing off function. “” will flicker and press “**Enter**” to enter timing off setting.

② At this moment, the last 2 digits of the nixie tube display “01” which means the first group setting begins. Press “**Enter**” to the next step.

③ By this time, the first 2 digits of the nixie tube will flicker and press “” or “” to adjust time of timing off.



Press “**mode**” to confirm and switch to minute setting automatically. The last 2 digits of the nixie tube will flicker and press “” or “” to adjust minute setting of timing off. Press “**Enter**” to confirm. The first group setting is finished and “” will be constantly light.



④ When processing timing setting of group 2, repeat the 1-2 operation above. When the nixie tube displays “01” and flicker, press “” or “” to choose the timing off group. When the nixie tube displays “02” which means setting timing off function of the second group.

Refers the timing off setting operation of group 1 to set that of group 2.

3.Cancel all timing on/off settings

Long press “mode” for 3s to enter function interface.

“” clock icon will flicker and press “mode” to choose the timing function. “” and “” flicker simultaneously means choosing to cancel all timing functions.

Press “Enter” to cancel timing settings. “” and “” both will be extinguished.

III.Functions of combination key



1.Force cooling



Press “” and “mode” simultaneously for 3s in the main interface to enter into force cooling mode. The force cooling mode icon will be constantly light.

Press “” button and “mode” button simultaneously for 3s to quit force cooling mode. The unit will enter power off mode automatically when quitting force cooling mode.

2.Parameter query function

①To enter parameter query function

Press “” and “” simultaneously for 3s to enter into the interface of parameter query function. At this moment, first 2 digits of the nixie tube  will display sequence number and the last 2 digits is specific parameters.

Press “” or “” to query the relative parameters. See query orders in Table 1-1.

②Quit parameter query function

If there's no operation in 20s when enter the parameter query, it will quit automatically and return to the main interface.



Press “” and “” simultaneously to quit parameter query manually.

Table.1-1 Query orders

No.	Content	Remark
1	Frequency	Display operating frequency when the unit is in cooling mode and heating mode.
2	Mode	0-Power off, 1-water pump, 2-cooling, 3-heating, 4-force cooling, 5-force heating
3	Wind speed level	0-Power off (1-7)
4	Total capacity requirements	Capacity before revised (Force cooling displays 5)
5	Capacity requirements after revised	Capacity after revised (Force cooling displays 5)
6	Temp. set	Cooling/heating temp. set
7	T3	Condenser temperature sensor
8	T4	Outdoor ambient temperature sensor
9	Tp	Comp. Discharge temperature sensor
10	Tin	Inlet water temperature sensor of plate heat exchanger
11	Tout	Outlet water temperature sensor of plate heat exchanger
12	Tb1	Plate heat exchanger anti-freezing temperature sensor 1
13	Tb2	Plate heat exchanger anti-freezing temperature sensor 2
14	T6	Radiator surface temperature(reserved)
15	Unit operation current	Unit operation current
16	Power supply voltage AD value	Power supply voltage AD value
17	Opening of EXV	Step number *8
18	Model	(Operation panel has no such function)
19	Version number	(Operation panel has no such function)
20	Err1	
21	Err2	(PCB has no such function)
22	Err3	(PCB has no such function)

3.Auto-lock (unlock) function

If don't operate the controller in 60s, the keyboard will lock automatically. Press “mode” and “Enter” simultaneously for 3s to unlock.

4.Factory Reset:

In main interface, long press “ENTER” for 3s, the unit will close and recovers to factory default mode. Display panel will display“OFF”

5. Error code and protection code shooting table:

E9	EEPROM malfunction
CP	Anti-idling protection of water pump
CL	Low temperature protection in heating mode
H0	Communication malfunction between the main controlling chip and IPDU
E4	T3&T4 temperature sensor malfunction
E5	Voltage protection
E6	DC fan motor malfunction
EA	Evaporator high temperature protection in heating mode
Eb	Two times of E6 protection in 10 minutes(Recover when powering off)
C0	Tin temperature sensor malfunction
C1	Tout temperature sensor malfunction
F7	Tb1 temperature sensor malfunction
F8	Tb2 temperature sensor malfunction
PL	Radiator high temperature protection
P1	High pressure protection
P2	Low pressure protection
P3	Outdoor units current protection
P4	Compressor discharge temperature protection
P5	Condenser high temperature protection
P6	IPM mode protection
P8	Typhoon protection
Pb	Outdoor units anti-freezing protection
C8	Flow switch malfunction
CH	High temperature protection in heating mode
dF	Defrosting
d0	Oil return of compressor
d8	Remote contact ON/OFF is active

Wired controller error code list KJR-120F1/BMK-E (CL92340):

EE	EEPROM error code(Wire controller)	C0	Tin temperature sensor malfunction
E9	EEPROM malfunction	C1	Tout temperature sensor malfunction
EA	5-minute error for heating mode fan in area A	C8	Flow switch malfunction
Eb	Two times of E6 protection in 10 minutes	CH	High temperature protection in heating mode
E4	T3&T4 temperature sensor malfunction	CL	Low temperature protection in heating mode
E5	Voltage protection	CP	Anti-idling protection of water pump
E6	DC fan motor malfunction	F7	Tb1 temperature sensor malfunction
H0	Communication malfunction between the main controlling chip and IPDU	F8	Tb2 temperature sensor malfunction
P1	High pressure protection	Pb	Outdoor units anti-freezing protection
P2	Low pressure protection	PL	Radiator high temperature protection
P3	Outdoor units current protection	PH	Water inlet and outlet temp. difference too large protection
P4	Compressor discharge temp. Protection	E2	Communication error between the wired controller and the chiller unit.
P5	Condenser high temperature protection		
P6	IPM mode protection		
P8	Typhoon protection		

If it is previewed not to use the machine for long periods
After deactivating the chiller:

- Make sure the model is in the Power off model "⏻",
or alternatively disconnect the unit from the power supply.
- Make sure the remote control switch is closed (if present) .
- Close the water valves.



If there is a possibility that the outside temperature may drop below zero, there is the risk of freezing. The water circuit **MUST BE EMPTIED AND SHUT OFF POWER** (when draining after heat pump operation take care as the water may be hot) or antifreeze must be added in the proportion recommended by the manufacturer.

Never perform any cleaning operations before having disconnected the unit from the mains power supply.

If the supply cord is damaged, it must be replaced by the manufacturer or its service agent or a similarly qualified person in order to avoid a hazard.

Regular maintenance is fundamental to maintain the efficiency of the unit both in terms of operation and energy consumption. The Technical Assistance Service maintenance plan must be observed, with an annual service which includes the following operations and checks:

- Filling of the water circuit
- Presence of air bubbles in the water circuit
- Efficiency of safety devices
- Power supply voltage

- Power input
- Tightness of electrical and hydraulic connections
- Condition of the compressor contactor
- Efficiency of the plate heat exchanger heater
- Checking of operating pressure, superheating and subcooling
- Efficiency of compressor heater
- Cleaning of finned coil (*)
- Cleaning of fan grills
- Cleaning of condensate drain pan (if installed).

(*) for "Heat pump" appliances, the checks are to be performed quarterly.

For units installed near the sea, the intervals between maintenance should be halved.

Never perform any cleaning operations before having disconnected the unit from the mains power supply.

CHEMICAL WASHING

You are recommended to chemically wash the plate heat exchanger after every 3 years of operation.

Draining of the circuit, causing the unit to function poorly. In this case, the leaks of refrigerant must be identified and repaired and the refrigerant circuit refilled. Proceed as follows:

- Empty and dry the entire refrigerant circuit using a vacuum pump connected to the low and high pressure tap until the vacuum reads about 10 Pa. Wait a couple of minutes and check that this value does not rise to more than 200 Pa.
- Connect the refrigerant gas cylinder or a filling cylinder to the low pressure line pressure gauge connection.
- Fill with the quantity of refrigerant gas indicated on the rating plate of the unit.
- Always check the superheating and subcooling values. In the nominal operating conditions for the appliance, these should be between 5 and 10°C and between 4 and 8°C respectively.
- After a couple of hours of operation, check that the liquid indicator indicates circuit dry (dry-green)

REFRIGERANT GAS CONTENT

The chillers are filled R410A refrigerant gas and tested in the factory. In normal conditions, there should be no need for the Technical Assistance Service to intervene to check the refrigerant gas. However, over time, small leaks may



In the event of partial leaks, the circuit must be completely emptied before being refilled.

The R410a refrigerant must only be filled in the liquid state.

Operating conditions other than nominal conditions may produce considerably different values.

Seal testing or identification of leaks must only be carried out using R410a refrigerant gas, checking with a suitable leak detector.



The refrigerant circuit must not be filled with a refrigerant other than that indicated on page 14.

The use of a different refrigerant may cause serious damage to the compressor.

Oxygen, acetylene or other inflammable or poisonous gases must never be used in the refrigerant circuit as they may cause explosion or poisoning.

Oils other than those indicated on pages 14 must not be used. The use of different oils may cause serious damage to the compressor.

1. Set temperature in cooling

Range:10~20℃ (default: 12℃)

If the set temperature is between 10~13℃, the compressor start and shut down according to the difference between the inlet temperature and the set temperature as follows:

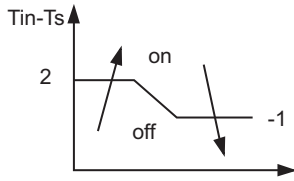

If the set temperature is between 14~20℃, the compressor start and shut down according to the difference between the inlet temperature and the set temperature as follows:

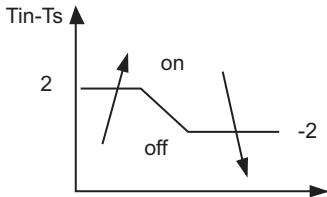

2. Set temperature in heating

Range:35~50℃ (default: 40℃)

If the set temperature is between 35~44℃, the compressor start and shut down according to the difference between the inlet temperature and the set temperature as follows:

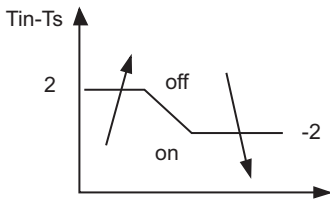

If the set temperature is between 45~50℃, the compressor start and shut down according to the difference between the inlet temperature and the set temperature as follows:

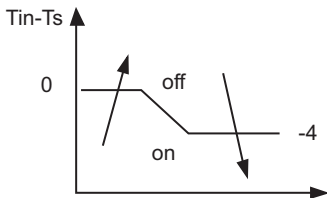

NOTE

The set temperature refers to the set return water temperature or inlet temperature;
In the event of a temporary power failure, when power returns, the mode set previously will be retained in the memory.

3. Compressor start up delay

In order to prevent the compressor frequent start and stop, the compressor must ensure that each start since the last stop since the minimum time of 300 seconds.

4. The pump control and the flow switch control

The electronic board includes two pumps control output. The pump 1 running 3 seconds, the pump 2 starts running. The pump 1 starts when the assembly is powered up and at least 285 seconds before the compressor starts up and stops 120 seconds after the assembly shuts down.

After the first 120 seconds of pump1 operation when the water flow meets the operating requirements, the water flow alarm functions are activated (differential pressure switch or flow switch). If the differential pressure switch (or flow switch) detects a continuous closure for 15 seconds, the unit can run normally, otherwise, it will shut down and display C8 fault.

In the unit operation process, if the continuous 10 seconds to detect the differential pressure switch (or flow switch) is opened, the unit will stop running and display C8 fault.

5. Fan speed control

For correct operation of the unit with different ambient temperatures, the microprocessor controls the fan speed based on the ambient temperature and the condensing or evaporation temperature as well as compressor frequency, thus enabling heat exchange to be increased and/or decreased, maintaining the condensing or evaporation temperature practically constant.

6. Frost prevention protection

To prevent the water freezing and damaging the plate heat exchanger, the microprocessor will perform antifreeze protection program if the heat exchanger temperature or the water temperature below a certain temperature.

a. In the cooling mode or water pump mode: if the heat exchanger temperature or the outlet temperature sensor is less than 3℃, the compressor will shut down and the controller display Pb code, the water pump will continue to run until the heat exchanger temperature or the outlet temperature sensor is above 8℃ and the unit will resume normal operation.

b. In the heating mode or standby mode: if the heat exchanger temperature or the inlet temperature sensor is less than 8℃, the controller display Pb code, the water pump will continue to run until the heat exchanger temperature or the inlet temperature sensor is above 15℃. If the heat exchanger temperature or the inlet temperature sensor continues to fall below 5℃, the unit will be forced heating operation, the compressor and the water pump will be running until the heat exchanger temperature or the inlet temperature sensor is above 15℃.

c. If the ambient temperature is less than 8℃ and the heat exchanger temperature or the inlet temperature sensor is less than 2℃, the electric exchanger temperature heating will turn on until the heat exchanger temperature or the inlet temperature sensor is above 7℃.

If the unit is likely to operate below 0℃, it is advisable to add antifreeze to the water system to prevent the unit from freezing the system in the event of a power cut off or failure.

7. Fin heat exchanger high temperature protection

When the fin heat exchanger temperature over than 62℃, system will shut down, but not returns to normal operation until the temperature decreased less than 52℃.

8. Comp. discharge temperature protection

If the compressor discharge temperature is more than 115℃, the compressor will be stop running until the temperature is lower than 83℃. The compressor starts with a 5 minute delay protection.



CAUTION

If there is a possibility that the outside temperature may drop below zero, there is the risk of freezing.
The water circuit **MUST BE EMPTIED AND SHUT OFF POWER** (when draining after heat pump operation take care as the water may be hot) or antifreeze must be added in the proportion recommended by the manufacturer.

Do not dispose this product as unsorted municipal waste. Collection of such waste separately for special treatment is necessary

Do not dispose of electrical appliances as unsorted municipal waste, use separate collection facilities.

Contact you local government for information regarding the collection systems available.

If electrical appliances are disposed of in landfills or dumps, hazardous substances can leak into the groundwater and get into the food chain, damaging your health and well-being.



FAULT	CAUSE	REMEDY
The chiller does not start up	No voltage	- Check presence of voltage - Check safety systems upstream of the appliance
	Mains switch in OFF position Remote switch (if present) in OFF position Control panel set to OFF Main unit switch in OFF position Compressor thermal solenoid switch OFF	Switch ON
	Supply voltage too low	Check power line
	Contactor coil faulty Electronic board faulty Start-up capacitor faulty (if present) Compressor faulty	Replace the component
Insufficient output	Insufficient refrigerant Sizing of unit Operation outside recommended limits	Check
Compressor noisy	Liquid returning to compressor Inadequate fixing	Check
	Reversed phase (three phase units only)	Reverse one phase
Noise and vibrations	Contact between metal bodies	Check
	Weak foundations	Repair
	Loose screws	Tighten screws
The compressor stops due to the activation of the protection devices	Excessive delivery pressure Low suction pressure Low voltage Electrical connections not sufficiently tight Operation outside permitted limits	Check
	Faulty operation of pressure switches	Thermal cut-out tripped
	Replace the component	Check supply voltage Check electrical insulation of windings

FAULT	CAUSE	REMEDY
High discharge pressure (greater than 36 bars)	High external water temperature High water inlet temperature	Check
	Insufficient air flow Insufficient water flow	Check fan operation Check pump operation
	Faulty fan regulation	Check
	Air in water circuit	Ventair
	Excessive refrigerant charge	Check
Low discharge pressure (less than 25 bars)	Low outside air temperature Low water inlet temperature	Check
	Moisture in the refrigerant circuit (liquid indicator - moisture yellow)	Faulty fan control
	Faulty fan control	Check
	Air in water circuit	Vent air
	Insufficient gas content	Check
High suction pressure (greater than 10 bars)	High outside air temperature High inflow water temperature	Check
Low suction pressure (less than 5.0 bars)	Low utility water inlet temperature Low external water inlet temperature Clogged water filter Blocked plate heat exchanger	Check

Model			5	7	10	12	12	14	16
Power supply		V-Ph-Hz	220-240, 1, 50	220-240, 1, 50	220-240, 1, 50	220-240, 1, 50	380-415, 3, 50	380-415, 3, 50	380-415, 3, 50
Cooling	Capacity	kW	5.0(1.9~5.8)	7.0(2.1~7.8)	10.0(2.9~10.5)	11.2(3.1~12.0)	11.2(3.1~12.0)	12.5(3.3~14.0)	14.5(3.5~15.5)
	rated Input	W	1550	2250	2950	3500	3380	3900	4700
	rated current	A	6.8	9.9	13.0	15.4	5.5	6.4	7.7
	EER	W/W	3.23	3.11	3.39	3.20	3.31	3.20	3.10
Heating	Capacity	kW	6.2(2.1~7.0)	8.0(2.3~9.0)	11.0(3.2~12.0)	12.3(3.3~13.2)	12.3(3.3~13.2)	13.8(3.5~15.4)	16.0(3.7~17.0)
	rated Input	W	1900	2500	3140	3780	3720	4250	4850
	rated current	A	8.3	11.0	13.8	16.6	6.1	7.0	8.0
	COP	W/W	3.26	3.20	3.50	3.25	3.31	3.25	3.30
Max. input consumption		W	2800	3000	4800	5200	5200	5600	5900
Max. input current		A	14.6	15.6	25.0	26.0	8.9	9.6	10.1
Refrigerant type /Quantity	Type		R410A	R410A	R410A	R410A	R410A	R410A	R410A
	Charged volume	g	2500	2500	2800	2800	2800	2900	3200
Dimension (W×H×D)		mm	1008×963×396			970×1327×400			
Packing (W×H×D)		mm	1120×1100×435			1082×1456×435			
Net/ Gross weight		kg	81/91			110/121		111/122	
Ambient temp.		°C	Cooling: -5°C~46°C; Heating: -15~27°C						
Water inlet setting temp. range (default)		°C	Cooling: 10~20°C(12°C); Heating mode: 35~50°C(40°C)						

This product has the fluorinated gas, it is forbidden to release to air.
 Refrigerant type: R410A; Volume of GWP: 2088;
 GWP=Global Warming Potential

Model	Factory charge	
	Refrigerant/kg	tonnes CO ₂ equivalent
5kW	2.50	5.22
7kW	2.50	5.22
10kW	2.80	5.85
12kW	2.80	5.85
14kW	2.90	6.06
16kW	3.20	6.68

Attention:

Frequency of Refrigerant Leak Checks

- 1) For equipment that contains fluorinated greenhouse gases in quantities of 5 tonnes of CO₂ equivalent or more, but of less than 50 tonnes of CO₂ equipment, at least every 12 months, or where a leakage detection system is installed, at least every 24 months.
- 2) For equipment that contains fluorinated greenhouse gases in quantities of 50 tonnes of CO₂ equivalent or more, but of less than 500 tonnes of CO₂ equipment, at least every six months, or where a leakage detection system is installed, at least every 12 months.
- 3) For equipment that contains fluorinated greenhouse gases in quantities of 500 tonnes of CO₂ equivalent or more, at least every three months, or where a leakage detection system is installed, at least every six months.
- 4) This air-conditioning unit is a hermetically sealed equipment that contains fluorinated greenhouse gases.
- 5) Only certificated person is allowed to do installation, operation and maintenance.

Cooling - Information requirements for comfort chillers

Information requirements for comfort chillers								
Model(s): MUENR-05-H6								
Outdoor side heat exchanger of air conditioner: Air								
Indoor side heat exchanger of air conditioner: Water								
Type: compressor driven vapour compression								
If applicable: driver of compressor: electric motor								
Item	Symbol	Value	Unit		Item	Symbol	Value	Unit
Rated cooling capacity	Prated,c	5,10	kW		Seasonal space cooling energy efficiency	$\eta_{s,c}$	246,0	%
Declared cooling capacity for part load at given outdoor temperatures Tj					Declared energy efficiency ratio or gas utilisation efficiency/auxiliary energy factor for part load at given outdoor temperatures Tj			
Tj = +35°C	Pdc	5,10	kW		Tj = +35°C	EERd	5,13	—
Tj = +30°C	Pdc	3,70	kW		Tj = +30°C	EERd	6,52	—
Tj = +25°C	Pdc	2,20	kW		Tj = +25°C	EERd	7,43	—
Tj = +20°C	Pdc	1,10	kW		Tj = +20°C	EERd	5,48	—
Degradation co-efficient for chillers (*)								
	Cdc	0,9	—					
Power consumption in modes other than 'active mode'								
Off mode	P _{OFF}	0,010	kW		Crankcase heater mode	PCK	0,000	kW
Thermostat-off mode	P _{TO}	0,001	kW		Standby mode	PSB	0,011	kW
Other items								
Capacity control	variable				For air-to-water comfort chillers: air flow rate, outdoor measured	—	3200	m ³ /h
Sound power level outdoor	L _{WA}	—/63	dB		For water/brine-to- water chillers: Rated brine or water flow rate, outdoor side heat exchanger	—	—	m ³ /h
Emissions of nitrogen oxides (if applicable)	NO _x (**)	—	mg/kWh fuel input GCV					
GWP of the refrigerant	—	2088	kg CO ₂ eq (100 years)					
Contact details	SALVADOR ESCODA SA PROVENZA 392 P2 08025 BARCELONA (SPAIN) +34 93 446 27 80							
(*) If Cdc is not determined by measurement then the default degradation coefficient of heat pumps shall be 0,9								
(**) From 26 September 2018								

Information requirements for comfort chillers

Model(s): MUENR-07-H6								
Outdoor side heat exchanger of air conditioner: Air								
Indoor side heat exchanger of air conditioner: Water								
Type: compressor driven vapour compression								
If applicable: driver of compressor: electric motor								
Item	Symbol	Value	Unit		Item	Symbol	Value	Unit
Rated cooling capacity	Prated,c	7,30	kW		Seasonal space cooling energy efficiency	$\eta_{s,c}$	262,0	%
Declared cooling capacity for part load at given outdoor temperatures Tj					Declared energy efficiency ratio or gas utilisation efficiency/auxiliary energy factor for part load at given outdoor temperatures Tj			
Tj = +35°C	Pdc	7,30	kW		Tj = +35°C	EERd	4,41	—
Tj = +30°C	Pdc	5,30	kW		Tj = +30°C	EERd	6,30	—
Tj = +25°C	Pdc	3,40	kW		Tj = +25°C	EERd	8,07	—
Tj = +20°C	Pdc	1,30	kW		Tj = +20°C	EERd	6,23	—
Degradation co-efficient for chillers (*)	Cdc	0,9	—					
Power consumption in modes other than 'active mode'								
Off mode	P _{OFF}	0,010	kW		Crankcase heater mode	PCK	0,000	kW
Thermostat-off mode	P _{TO}	0,001	kW		Standby mode	PSB	0,011	kW
Other items								
Capacity control	variable				For air-to-water comfort chillers: air flow rate, outdoor measured	—	3750	m ³ /h
Sound power level outdoor	L _{WA}	—/66	dB		For water/brine-to- water chillers: Rated brine or water flow rate, outdoor side heat exchanger	—	—	m ³ /h
Emissions of nitrogen oxides (if applicable)	NO _x (**)	—	mg/kWh fuel input GCV					
GWP of the refrigerant	—	2088	kg CO2 eq (100 years)					
Contact details	SALVADOR ESCODA SA PROVENZA 392 P2 08025 BARCELONA (SPAIN) +34 93 446 27 80							
(*) If Cdc is not determined by measurement then the default degradation coefficient of heat pumps shall be 0,9								
(**) From 26 September 2018								

Heating - Information requirements for heat pump space heaters and heat pump combination heaters

Information requirements for heat pump space heaters and heat pump combination heaters							
Model(s): MUENR-05-H6							
Air-to-water heat pump: Yes							
Water-to-water heat pump: No							
Brine-to-water heat pump: No							
Low-temperature heat pump: Yes							
Equipped with a supplementary heater: No							
Heat pump combination heater: No							
For low-temperature heat pumps, parameters shall be declared for low-temperature application. Otherwise, parameters shall be declared for medium-temperature application.							
Parameters shall be declared for average climate conditions.							
Item	Symbol	Value	Unit	Item	Symbol	Value	Unit
Rated heat output (*)	Prated	6	kW	Seasonal space heating energy efficiency	η_s	139	%
Declared capacity for heating for part load at outdoor temperature T_j				Declared coefficient of performance or primary energy ratio for part load at outdoor temperature T_j			
$T_j = -7\text{ °C}$	Pdh	5,5	kW	$T_j = -7\text{ °C}$	COPd	2,50	–
$T_j = +2\text{ °C}$	Pdh	3,6	kW	$T_j = +2\text{ °C}$	COPd	3,88	–
$T_j = +7\text{ °C}$	Pdh	2,2	kW	$T_j = +7\text{ °C}$	COPd	4,56	–
$T_j = +12\text{ °C}$	Pdh	1,1	kW	$T_j = +12\text{ °C}$	COPd	4,15	–
$T_j =$ bivalent temperature	Pdh	5,5	kW	$T_j =$ bivalent temperature	COPd	2,50	–
$T_j =$ operation limit temperature	Pdh	5,1	kW	$T_j =$ operation limit temperature	COPd	2,45	–
For air-to-water heat pumps: $T_j = -15\text{ °C}$	Pdh	x,xx	kW	For air-to-water heat pumps: $T_j = -15\text{ °C}$	COPd	x,xx	–
Bivalent temperature	Tbiv	-7	°C	For air-to-water HP : Operation limit temperature (maximum -7°C)	Tol	-10	°C
Cycling interval capacity for heating	Pcyh	x,xx	kW	Cycling interval efficiency	COPcyc	x,xx	–
Degradation coefficient (**)	Cdh	0,90	–	Heating water operating limit temperature	WTOL	x,xx	°C
Power consumption in modes other than active mode				Supplementary heater			
Off mode	P _{OFF}	0,011	kW	Rated heat output (**)	P _{sup}	x,xx	kW
Thermostat-off mode	P _{TO}	0,011	kW	Type of energy input	–		
Standby mode	P _{SB}	0,005	kW				
Crankcase heater mode	P _{CK}	0,032	kW				
Other items							
Capacity control	fixed/variable	variable	Outdoor heat exchanger				
Sound power level, indoors	L _{WA}	x	db(A)	For air-to-water HP: Rated air flow rate, outdoors	Q _{airsource}	3200	m ³ /h
Sound power level, outdoors	L _{WA}	63	db(A)	For water-to-water HP: Rated water flow rate	Q _{watersource}	x	m ³ /h
Annual energy consumption	QHE	3600	kWh	For brine-to-water HP: Rated brine flow rate	Q _{brinesource}	x	m ³ /h
For heat pump combination heater:							
Declared load profile	–			Water heating energy efficiency	η_{wh}	x	%
Daily electricity consumption	Q _{elec}	x	kWh	Daily fuel consumption	Q _{fuel}	x	kWh
Annual electricity consumption	AEC	x	kWh	Annual fuel consumption	AFC	x	GJ
Contact details	SALVADOR ESCODA SA PROVENZA 392 P2 08025 BARCELONA (SPAIN) +34 93 446 27 80						
(*) For heat pump space heaters and heat pump combination heaters, the rated heat output Prated is equal to the design load for heating Pdesignh, and the rated heat output of a supplementary heater Psup is equal to the supplementary capacity for heating sup(Tj).							
(**) If Cdh is not determined by measurement then the default degradation coefficient is Cdh = 0,9.							

Information requirements for heat pump space heaters and heat pump combination heaters							
Model(s): MUENR-07-H6							
Air-to-water heat pump: Yes							
Water-to-water heat pump: No							
Brine-to-water heat pump: No							
Low-temperature heat pump: Yes							
Equipped with a supplementary heater: No							
Heat pump combination heater: No							
For low-temperature heat pumps, parameters shall be declared for low-temperature application. Otherwise, parameters shall be declared for medium-temperature application.							
Parameters shall be declared for average climate conditions.							
Item	Symbol	Value	Unit	Item	Symbol	Value	Unit
Rated heat output (*)	Prated	8	kW	Seasonal space heating energy efficiency	η_s	135	%
Declared capacity for heating for part load at outdoor temperature Tj				Declared coefficient of performance or primary energy ratio for part load at outdoor temperature Tj			
Tj = - 7 °C	Pdh	5,7	kW	Tj = - 7 °C	COPd	2,30	-
Tj = + 2 °C	Pdh	4,4	kW	Tj = + 2 °C	COPd	3,48	-
Tj = + 7 °C	Pdh	2,9	kW	Tj = + 7 °C	COPd	5,60	-
Tj = + 12 °C	Pdh	1,3	kW	Tj = + 12 °C	COPd	4,30	-
Tj = bivalent temperature	Pdh	6,3	kW	Tj = bivalent temperature	COPd	2,54	-
Tj = operation limit temperature	Pdh	5,5	kW	Tj = operation limit temperature	COPd	2,30	-
For air-to-water heat pumps:Tj = - 15 °C	Pdh	x,xx	kW	For air-to-water heat pumps:Tj = - 15 °C	COPd	x,xx	-
Bivalent temperature	Tbiv	-4	°C	For air-to-water HP : Operation limit temperature (maximum -7°C)	ToI	-10	°C
Cycling interval capacity for heating	Pcyh	x,xx	kW	Cycling interval efficiency	COPcyc	x,xx	-
Degradation coefficient (**)	Cdh	0,90	-	Heating water operating limit temperature	WTOL	x,xx	°C
Power consumption in modes other than active mode				Supplementary heater			
Off mode	P _{OFF}	0,011	kW	Rated heat output (**)	P _{sup}	x,xx	kW
Thermostat-off mode	P _{TO}	0,011	kW	Type of energy input	-		
Standby mode	P _{SB}	0,005	kW				
Crankcase heater mode	P _{CK}	0,032	kW				
Other items							
Capacity control	fixed/variable	variable	Outdoor heat exchanger				
Sound power level, indoors	L _{WA}	x	db(A)	For air-to-water HP: Rated air flow rate, outdoors	Q _{airsource}	3750	m ³ /h
Sound power level, outdoors	L _{WA}	66	db(A)	For water-to-water HP: Rated water flow rate	Q _{watersource}	x	m ³ /h
Annual energy consumption	QHE	4750	kWh	For brine-to-water HP: Rated brine flow rate	Q _{brinesource}	x	m ³ /h
For heat pump combination heater:							
Declared load profile	-			Water heating energy efficiency	η_{wh}	x	%
Daily electricity consumption	Q _{elec}	x	kWh	Daily fuel consumption	Q _{fuel}	x	kWh
Annual electricity consumption	AEC	x	kWh	Annual fuel consumption	AFC	x	GJ
Contact details	SALVADOR ESCODA SA PROVENZA 392 P2 08025 BARCELONA (SPAIN) +34 93 446 27 80						
(*) For heat pump space heaters and heat pump combination heaters, the rated heat output Prated is equal to the design load for heating Pdesignh, and the rated heat output of asupplementary heater Psup is equal to the supplementary capacity for heating sup(Tj).							
(**) If Cdh is not determined by measurement then the default degradation coefficient is Cdh = 0,9.							

MUNDO  CLIMA®



www.mundoclima.com

ASK FOR MORE INFORMATION

Phone: (+34) 93 446 27 80

eMail: info@mundoclima.com

TECHNICAL ASSISTANCE

Phone: (+34) 93 652 53 57