

High Pressure Duct

Installation manual



CONTENTS	PAGE
INSTALLATION PRECAUTION.....	1
INSTALLATION PLACE.....	1
ACCESSORIES.....	2
INDOOR UNIT INSTALLATION	2
INSTALLATION SPACE.....	4
REFRIGERANT PIPE.....	4
DUCT DESIGN.....	4
INSTALL THE CONNECTING PIPE.....	6
REFRIGERANT PIPE CONNECTION.....	6
CONNECT THE DRAIN PIPE.....	8
WIRING.....	8
CONTROL.....	9
TROUBLE SHOOTING.....	11
INSTALL ELECTRIC THROTTLE PART.....	11
INSTALL BRANCH PIPE.....	11
TEST OPERATION.....	12
FRESH AIR HARDING UNIT CONFIGURATION INSTRUCTIONS.....	12

- If the supply cord is damaged, it must be replaced by the manufacturer or its service agent or a similarly qualified person in order to avoid a hazard.
- An all-pole disconnection switch having a contact separation of at least 3mm in all poles should be connected in fixed wiring.
- The appliance shall be installed in accordance with national wiring regulations.
- The temperature of refrigerant circuit will be high, please keep the interconnection cable away from the copper tube.
- An all-pole disconnection device which has at least 3mm separation distance in all pole and a residual current device(RCD)with the rating of above 10mA shall be incorporated in the fixed wiring according to the national rule.

The power cord type designation is H05RN-R/H07RN-F or above.

2. INSTALLATION PLACE

- Indoor Unit
 - Enough room for installation and maintenance.
 - The ceiling is horizontal and it can afford the weight of the indoor unit.
 - The air inlet and outlet are not impeded and does not affected by outdoor air too much.
 - The air flow can reach every part of the room.
 - The connecting pipe and drainpipe can be easily extracted out.
 - There is no direct radiation from heat source.
- Outdoor Unit
 - Enough room for installation and maintenance.
 - The air inlet and outlet are not impeded and does not affected by outdoor air too much.
 - Dry and well ventilated place.
 - The supporter is flat and horizontal and can afford the weigh of outdoor unit, without noise and vibration.
 - The noise and the outlet air will not influence your neighbor.
 - No combustible gas.
 - Place convenient for piping and wiring.
 - Please keep away from the following places, or malfunction may be caused.(if unavoidable, please consult the professionals):
 - There is mineral oil like the oil of cutting machine.
 - There is much salty air. (Near the coast)
 - There is caustic gas such as sulfuric gas. (Near the hot spring.)
 - Factory where the voltage fluctuate greatly.
 - In the car or in the cabin.
 - In the kitchen or a place full of oil steam.
 - There is strong electromagnetic wave.
 - There is combustible gas or materials.

1. INSTALLATION PRECAUTION

- To install properly, please read this manual at first.
- The air conditioner must be installed by qualified persons.
- When installing the indoor unit or its tubing, please follow this manual as strictly as possible.
- When all the installation work is finished, please turn on the power only after a thorough check.
- No further announcement if there is any change of this manual caused by product improvement.



NOTE

The installer should illustrate to users how to correctly use and maintain the air-conditioner, as well as remind users to carefully read and keep both Installation Manual and Owner's Manual well.



CAUTION

- DISPOSAL: Do not dispose this product as unsorted municipal waste. Collection of such waste separately for special treatment is necessary.



- This appliance is not intended for use by persons (including children) with reduced physical, sensory or mental capabilities, or lack of experience and knowledge, unless they have been given supervision or instruction concerning use of the appliance by a person responsible for their safety. Children should be supervised to ensure that they do not play with the appliance.
- Disconnect the power supply before cleaning and maintenance.
- The appliance must be installed 2,3m above floor.
- The appliance shall not be installed in the laundry.









- There is much evaporating acid or alkaline gas.
- Other special areas.
- Notes Before Installation
- Select the correct carry-in path.
- Move this unit as originally packaged as possible.
- If the air conditioner is installed on a metal part of the building, it must be electrically insulated according to the relevant standards to electrical appliances.
- Avoid installing it in a narrow space which has a high requirement to noise.

NOTE





- Remark per EMC Directive 89/336/EEC
- For to prevent flicker impressions during the start of the compressor(technical process),following installation conditions apply.
- The power connection for the air conditioner has to be done at the main power distribution. The distribution has to be of a low impedance, normally the required impedance reaches at a 32A fusing point.
- No other equipment has to be connected with this power line.
- For detailed installation acceptance, please refer to your contract with the power supplier if restrictions do apply for products like washing machines, air conditioners or electrical ovens.
- For power details of the air conditioner, refer to the rating plate of the product.
- For any question contact your local dealer.

3. ACCESSORIES

Table.3-1

Name of Accessories	Q'ty	Outline	Usage
Installation manual	1	(This manual)	_____
Wire controller	1		Wire control the air-conditioner
Pipe insulation material	4		Heat insulation
Clasp	1		Chucking the joint which connect the drain hose and the outlet of indoor unit
Water connecting pipe	1		To connect drain pipe
Network matching wire	1		The indoor unit which at the terminal of communication system should connect a impedance between port P and port Q
Branch header package	2		To connect the AB system
EXV connecting pipe ass'y	2		To connect the throttle components.
Copper nut	2		Use for pipe connection of engineering installation

The following are selectable accessories

Remote controller & Its Frame	
1. Remote controller.....	1
	
2. Remote controller holder.....	1
	
3. Mounting screw (ST2.9x10-C-H).....	2
	
4. Alkaline dry battery(AM4).....	2
	

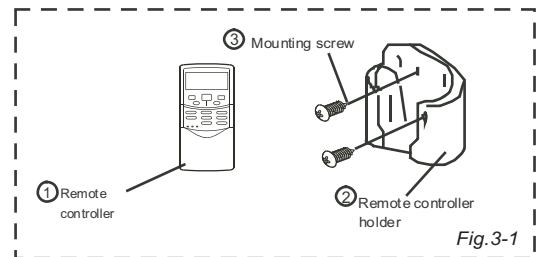

- Cautions on remote controller installation
- Never throw or beat the controller.
- Before installation, operate the remote controller to determine its location in a reception range.
- Keep the remote controller at least 1m apart from the nearest TV set or stereo equipment. (It is necessary to prevent image disturbances or noise interferences.)
- Do not install the remote controller in a place exposed to direct sunlight or close to a heatingsource, such as a stove. Note that the positive and negative poles are in right positions when loading batteries.

4. INDOOR UNIT INSTALLATION

Installing Φ10 Hanging Screw Bolts (4 Bolts)

- Please refer to the following figure for the distance measurement between the screw bolts.
- Please install with screw bolts.
- The handling to the ceiling varies from the constructions, consult the construction personnels for the specific procedures.
- The size of the ceiling to be handled. Do keep the ceiling flat. Consolidate the roof beam for possible vibration.
- Cut off the roof beam.
- Strengthen the place cut off, and consolidate the roof beam.
- Carry out the pipe and line operation in the ceiling after finishing the installation of the main body. While choosing where to start the operation, determine the direction of the pipes to be drawn out. Especially in case there is a ceiling, position the refrigerant pipes, drain pipes, indoor & outdoor lines to the connection places before hanging up the machine.
- The installation of hanging screw bolts.

Wooden construction

Put the square timber transversely over the roof beam, then install the hanging screw bolts. (Refer to Fig.4-1)

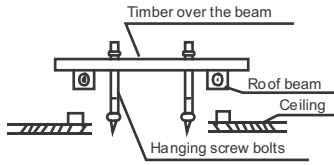

Fig.4-1

New concrete bricks

Inlaying or embedding the screw bolts (Refer to Fig.4-2)

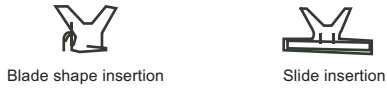

Fig.4-2

For original concrete bricks

Use embedding screw bolt, crock and stick harness (refer to Fig.4-3)

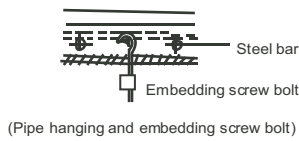

Fig.4-3

Steel roof beam structure

Install and use directly the supporting angle steel. (refer to Fig.4-4)

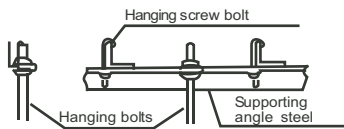

Fig.4-4

- Overhanging the indoor unit
- Overhang the indoor unit onto the hanging screw bolts with block.
- Position the indoor unit in a flat level by using the level indicator, unless it may cause leakage.

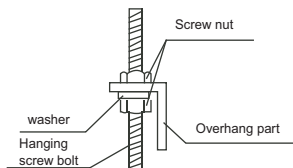

Fig.4-5

■ Install the main body

- Installing the canvas air passage
- Pipe Connection
The static pressure outside the unit is 200Pa, the length of the air pipe attached is determined by this parameter.
- The positioning of ceiling hole and indoor unit and hanging screw bolts

- ① Routine method of installation: the size of installation for indoor unit following Fig.4-6
- ② Please install with Φ10 hanging screw bolts.
- ③ Carry out the pipe and line operation in the ceiling after finishing the installation of the main body. While choosing where to start the operation, determine the direction of the position the refrigerant pipes, drain pipes, indoor & outdoor lines and line-controlled lines to the connection places before.

■ The positioning of ceiling hole and indoor unit and hanging screw bolts

routine method of installation: the size of installation for indoor unit following the Fig.4-6 and Fig.4-9

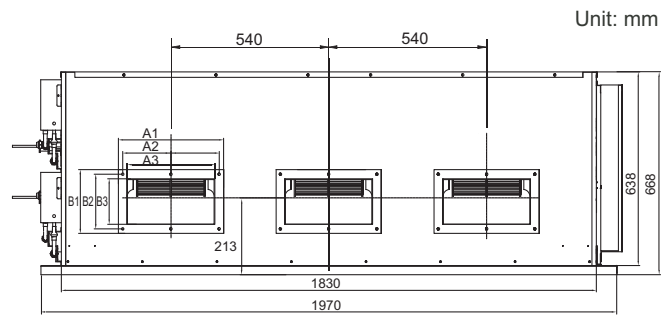

Unit: mm

Front view (Air supply outlet)

	40kW, 50Hz	45kW, 50Hz	56kW, 50Hz
A1	360		394
A2	330		364
A3	300		334
B1	210		247
B2	180		217
B3	150		187

Fig.4-6

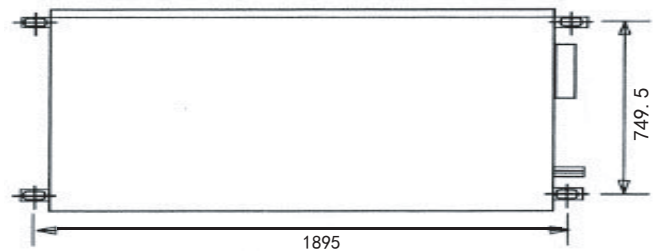

Fig.4-7

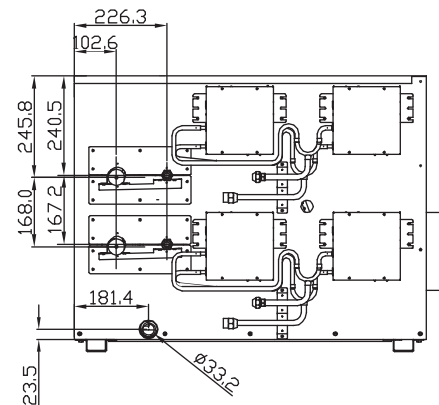
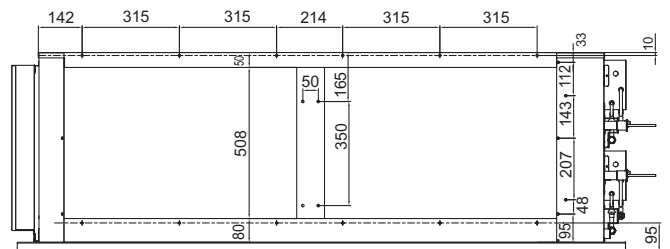

Fig.4-8



Rear view (Air return vent)

Fig.4-9



CAUTION

Please shut down the unit and cut off power cable before maintain the motor.



NOTE

- During teardown and installation, the scroll was allowed direct support by hand
- Fan subassembly is more weightiness, please take careful during teardown and installation, and keep from hurt by fan subassembly.

5. INSTALLATION SPACE

Confirm that there is enough room for installation and maintenance.

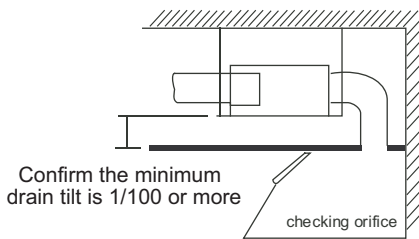
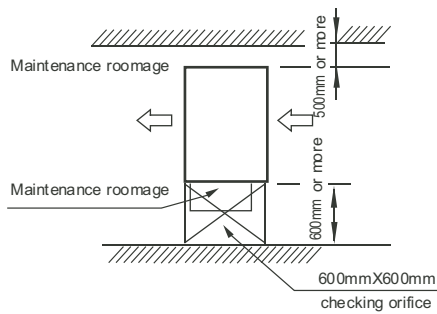

6. REFRIGERANT PIPE

- Cover the pipe before connecting to keep rubbish, dust or other impurities out.
- Pipeline to connect the reference air conditioner outdoor unit requirements.

7. DUCT DESIGN

- Cover the pipe before connecting to keep rubbish, dust or other impurities out.
- Key points of duct connection

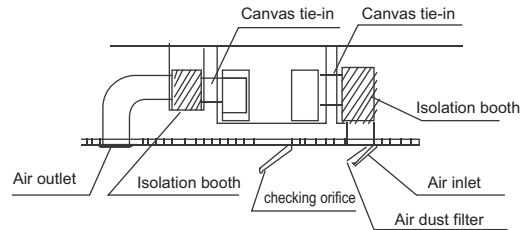

NOTE

Other assemblies should be prepared on spot except air conditioner main body.

- High Static Pressure Type

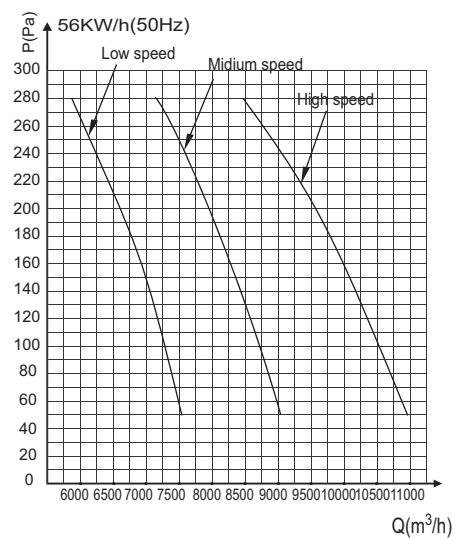
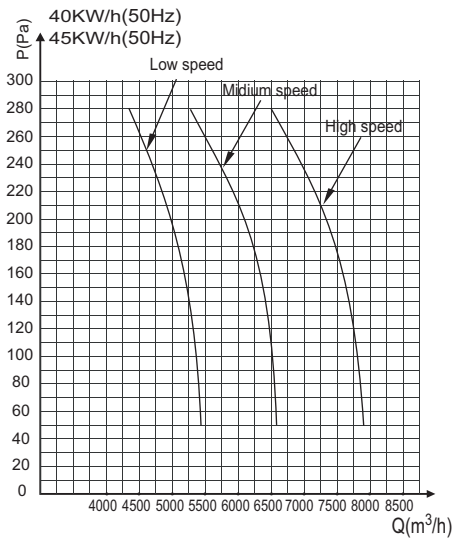

■ Panel installation

- Unload inner frame.
Slide the knob, release the buckle from the outside frame hole, then unload the inner frame.

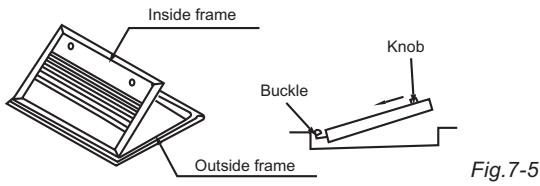

- Hang the outside frame on the main body with face down. (4 places at 4 corners).
Hang the belt on the hook of the main body.

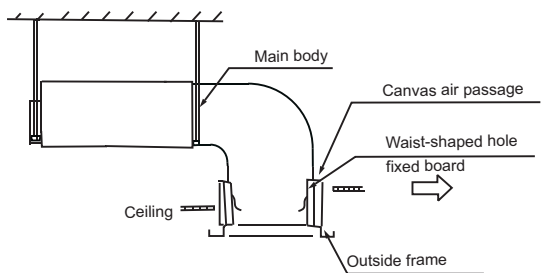

Fig. 7-6

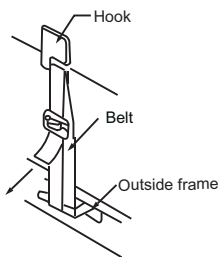

Fig. 7-7



NOTE

The signal wire of the remote control receiver must be drawn out through the canvas air passage.

- Fix the outside frame and the canvas air passage with screws.
Screw must be fixed on from the bottom to the top.

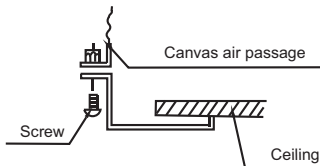

- Hang up the outside frame until it sticks to the ceiling tightly.

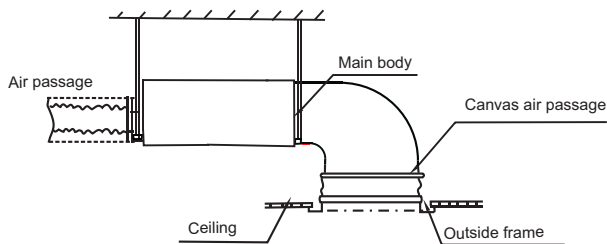

Fig. 7-9

- Fix the main body and the outside frame with the fix board of waist-shape hole (in two places).
 - ① Hang one side of the fix board of the waist-shaped hole on the hook of the main body.
 - ② Tighten the other side of the board with screw to the outside frame.
 - ③ Cut off the surplus part of the board with pliers.
 - ④ Bend the top of the broken end.



NOTE

When hanging up the outside frame with the fix board of waist-shaped hole and the belt, stick the outside frame tightly to the ceiling and fix it.

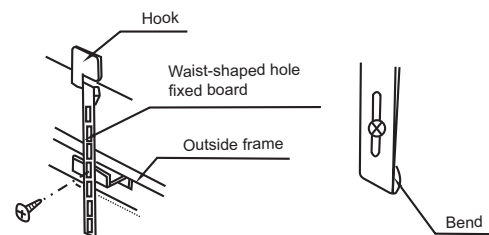

Fig. 7-10

- Install the inner frame on the outside frame (the inverse sequence of unloading the inner frame).

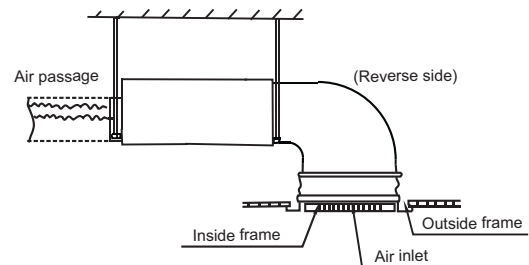

Fig. 7-11



NOTE

Connect the remote control receiver with the indoor unit signal wires and fix it.

- Install remote controller.

8. INSTALL THE CONNECTING PIPE

■ Check whether the height drop between the indoor unit and outdoor unit, the length of refrigerant pipe, and the number of the bends meet the following requirements:

- The max height drop and The length of refrigerant pipe depending on the outdoor unit. (If the height drop is more than 10m, you had better put the outdoor unit over above the indoor unit.)
- The number bends fewer than 15.
- Do not let air, dust, or other impurities fall in the pipe system during the time of installation.
- The connecting pipe should not be installed until the indoor and outdoor units have been fixed already.
- Keep the connecting pipe dry, and do not let moisture in during installation.

■ The Procedure of Connecting Pipes

Measure the necessary length of the connecting pipe, and make it by the following way.

- Connect the indoor unit at first, then the outdoor unit.
- ① Bend the tubing in proper way. Don,t harm them.
- ② Daub the surfaces of the flare pipe and the joint nuts with frozen oil, and wrench it for 3~4 rounds with hands before fasten the flare nuts. (Refer to Fig.8-1)
- ③ Be sure to use two wrenches simultaneously when you connect or disconnect the pipes.
- The stop valve of the outdoor unit should be closed absolutely (as original state). Every time you connect it, first loosen the nuts at the part of stop valve, then connect the flare pipe immediately (in 5 minutes). If the nuts have been loosened for a long time, dusts and other impurities may enter the pipe system and may cause malfunction later. So please expel the air out of the pipe with refrigerant before connection.
- Expel the air (refer to the "Expel The Air") after connecting the refrigerant pipe with the indoor unit and the outdoor unit. Then fasten the nuts at the repair-points.

■ Notices For Benable pipe.

- The bending angle should not exceed 90°C
- Bending position is preferably in the bendable pipe. The larger the better it is .
- Do not bend the pipe more than three times.
- Bend the connecting pipe of small wall thickness.
- Cut out a desired concave at the bending part of the insulating pipe.
- Then expose the pipe(cover it with tapes after bending).
- To prevent collapsing of deforming, please bend the pipe at its biggest radius.
- Use bender to get a small radius pipes.
- Use the market brass pipe.
Be sure to use the same insulating materials when you buy the brass pipe. (More than 9mm thick)

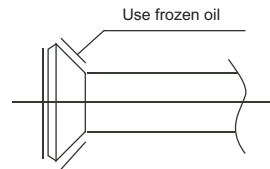

Fig.8-1

Bend the pipe with thumb



Fig.8-2

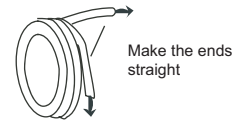

Fig.8-3

■ Locate The Pipe

- Drill a hole in the wall (suitable just for the size of the wall conduit, 90mm in general), then set on the fittings such as the wall conduit and its cover.
- Bind the connecting pipe and the cables together tightly with binding tapes. Do not let air in, which will cause water leakage by condensation.
- Pass the bound connecting pipe through the wall conduit from outside. Be careful of the pipe all ocation to do no damage to the tubing.
- Connect the pipes.
- Then, open the stem of stop valves of the outdoor unit to make the refrigerant pipe connecting the indoor unit with the outdoor unit fluently flow.
- Be sure of no leakage by checking it with leak detector or soap water.
- Cover the joint of the connecting pipe to the indoor unit with the sound proof/insulating sheath (fittings), and bind it well with the tapes to prevent leakage.

9. REFRIGERANT PIPE CONNECTION

9.1 Expel The Air

- Flaring
- Cut a pipe with a pipe cutter.
- Insert a flare nut into a pipe and flare the pipe.

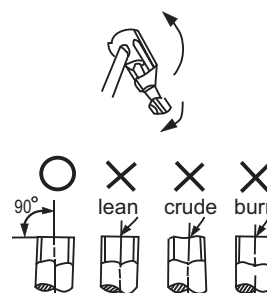
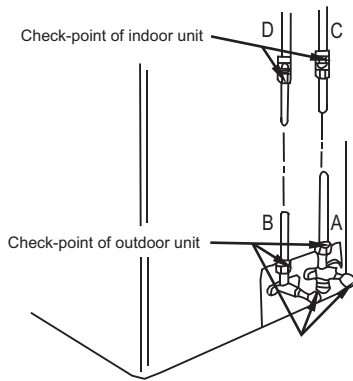

Fig.9-1

9.2 Check The Leakage

- Check all the joints with the leak detector or soap water. (See Fig.9-6 as a reference illustration)



A. Lo-stop valve B. Hi-stop valve
C,D. Joints of the connecting pipe to the indoor unit.

Fig.9-2

9.3 Insulation

- Be sure to with insulating materials cover all the exposed parts of the flare pipe joints and refrigerant pipe on the liquid-side and the gas-side. Ensure that there is no gap between them.
- Incomplete insulation may cause water condensation.

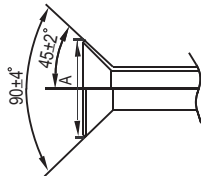

Fig.9-3

Table.9-1

Outside diameter	A(mm)	
	Max	Min
Φ6.4mm	8.7	8.3
Φ9.5mm	12.4	12.0
Φ12.7mm	15.8	15.4
Φ15.9mm	19.0	18.6
Φ19.1mm	23.3	22.9

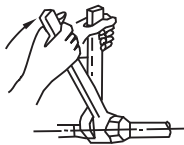

Fig.9-4

Table.9-2

Tubing size	Torque
Φ6.4mm	14.4~17.2N.m
Φ9.5mm	32.7~39.9N.m
Φ12.7mm	49.5~60.3N.m
Φ15.9mm	61.8~75.4N.m
Φ19.1mm	92.7~118.6N.m

- Fasten the nut
 - Put the connecting tubing at the proper position, wrench the nuts with hands then fasten it with a wrench. (Refer to Fig.9-4)
 - Too large torque will harm the bellmouthing and too small will cause leakage. Please determine the torque according to Table.9-2.

- The necessary filling amount of refrigerant
 - Refrigerant volume to be added is calculated according to outdoor unit installation manual .Be sure to add refrigerant measuring by a scale. L: The length of the pipe
 - Please record the quantity added and store it carefully for future maintenance.
- Expel the air with a vacuum pump (Refer to Fig.9-4) (Please refer to its manual for the way of using manifold valve)
 - Loosen and remove the maintenance nuts of stop valves A and B, and connect the charge hose of the manifold valve with the maintenance terminator of stop valve A. (Be sure that stop valves A and B are both closed)
 - Connect the joint of the charge hose with the vacuum pump.
 - Open the Lo-lever of the manifold valve completely.
 - Turn on the vacuum pump. At the beginning of pumping, loosen the maintenance terminator nut of stop valve B a little to check whether the air comes in (the sound of the pump changes, and the indicator of compound meter turns below zero). Then fasten the nut.
 - When the pumping has finished, close the Lo-lever of the manifold valve completely and turn off the vacuum pump.
 - When you have pumped for over 15 minutes, please confirm that the indicator of multimeter is on $-1.0 \times 10^5 \text{Pa}$ (-76cmHg)
 - Loosen and remove the quadrangle cover of stop valves A and B to open stop valve A and B completely, then fasten them.
 - Disassemble the charge hose from the repair-mouth of stop valve A, and fasten the nut.

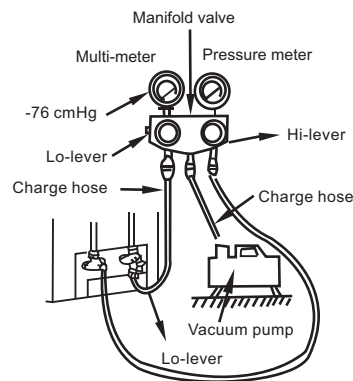

Fig.9-5

- All the stop valves should be opened before test operation. Each air conditioner has two stop valves of different sizes on the side of the outdoor unit which operate as Lo-stop value, respectively. (Refer to Fig.9-6)

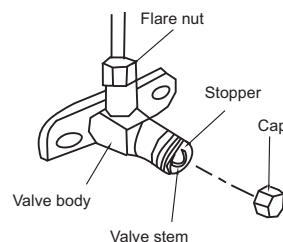

Fig.9-6

10. CONNECT THE DRAIN PIPE

- Install indoor unit drain pipe

For 400 to 560 indoor unit, please use water connecting pipe and Adhesive tape for seal when connecting drain pipes.



CAUTION

- The drain pipe of indoor unit must be heat insulated, or it will condense dew, as well as the connections of the indoor unit.
- Hard PVC binder must be used for pipe connection, and make sure there is no leakage.
- With the connection part to the indoor unit, please be noted not to impose pressure on the side of indoor unit pipes.
- When the declivity of the drain pipe downwards is over 1/100, there should not be any winding.
- The total length of the drain pipe when pulled out transversely shall not exceed 20m, when the pipe is over long, a prop stand must be installed to prevent winding.
- The height difference between drain pipe end to ground or drain channel should be more than 50mm, and the drain pipe cannot put in water. If the drain water was discharged to ditch directly, the drain pipe must be upward bent into a U type water seal to avoid odor into the interior through the drain pipe.
- If the negative pressure of drain pan outlet is high, there must be a water elbow in drain pipe to avoid poor drain or blow water for negative pressure. Please install the water elbow as figure 4.4 shown, each unit should install a water elbow. There should be a plug in water elbow for convenient cleaning.
- Refer to the figures on the right for the installation of the pipes.

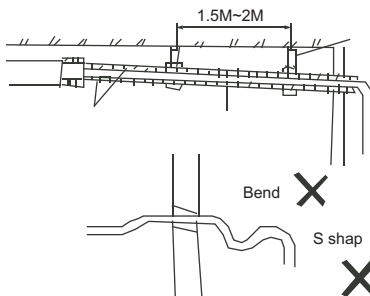

Fig.10-1

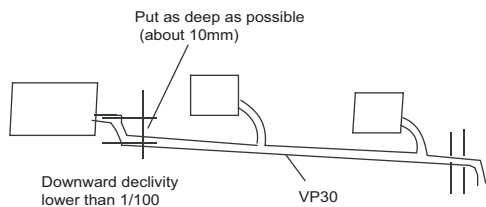

Fig.10-2

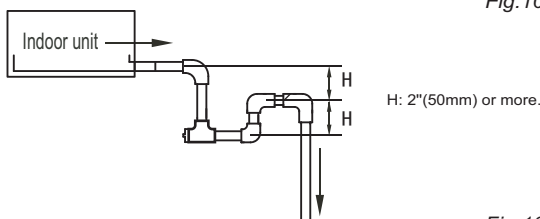

Fig.10-3

Caution: While connecting the drain pipe, please use the drain pipe connect to the secondary water holder simultaneously, for avoiding there are little condensate water deposit in the unit when the machine is running under the high humidity working condition.

11. WIRING

- Attaching wiring
- The air conditioner should use separate power supply with rated voltage.
- The external power supply to the air conditioner should have ground wiring, which is linked to the ground wiring of the indoor and outdoor unit.
- The wiring work should be done by qualified persons according to circuit drawing.
- A leakage protector should be installed according to the National Standard concerning electrical appliance.
- Be sure to locate the power wiring and the signal wiring well to avoid cross-disturbance and their contact with connecting pipe or stop valve body.
- The wiring attached to this air conditioner is 10m long. Be sure to prolong it with wiring of the same type and proper length if necessary. Generally, do not twist two wiring together unless the joint is soldered well and covered with insulator tape.
- Do not turn on the power until you have checked carefully after wiring.

■ The Specification of Power

Table.11-1

Capacity(KW)		40~56kW(50Hz)
Power	Phase	1-Phase
	Frequency and volt	220-240V~ 50Hz
Circuit breaker/fuse (A)		20/15
Indoor unit power wiring (mm ²)		2.5(<20 m)-4.0(<50 m)
Indoor/outdoor connecting wiring(mm ²)	Ground wiring	2.5
	Weak electric signal	0.75(<1200 m)



CAUTION

A disconnection device having an air gap contact separation in all active conductors should be incorporated in the fixed wiring according to the National Wiring Regulation.

■ Communication Wiring Chart

Communication wiring will be different according to the horsepower of air-conditioners. The wiring of 450 to 560 indoor unit, please refer to Fig.11-1.

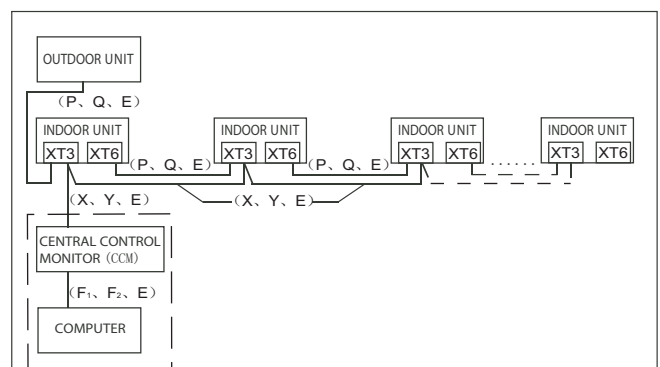

Fig.11-1



CAUTION

The reserved function is indicated in broken line table, users can select it when necessary.

■ Terminal board diagram

Please refer to the indoor unit wiring diagram for the detailed wiring. In accord with the communication wiring, terminal board wiring is different according to the horsepower of air-conditioners. The wiring of 450T1 to 560T1 indoor unit, please refer to Fig.11-2.



NOTE

The air-conditioners can connect with Central Control Monitor (CCM). Before operation, please wiring correctly and set system address and network address of indoor units.

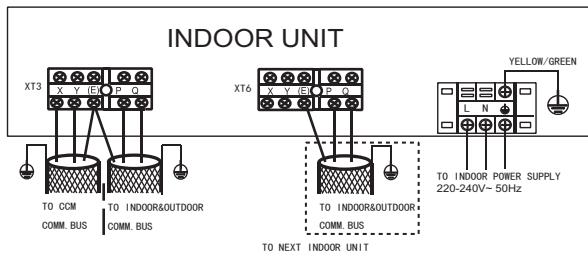

Please use 3-core shielding wire, and ground the shielding layer.

Fig. 11-2

12. CONTROL

■ Capacity set

Base on different purposes to set the switch codes on the main boards of indoor unit, Once finish the setting, please cut off the main power, and then switch on the power again. Otherwise, setting functions could not work.

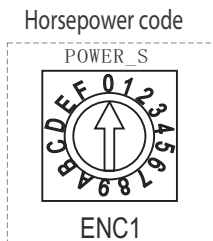

Fig. 12-1

ENC1 is used for setting the refrigeration capacity(refer to Table.12-1 for different indoor unit) of the indoor unit.

Table.12-1







ENC1	Toggle switch	For set horsepower	
Note: The horsepower has been set before leaving the factory, anyone can't modify it except the maintenance person.	Code	Capacity(Horsepower)	
	0	2200W(0.8HP)	
	1	2800W(1.0HP)	
	2	3600W(1.2HP)	
	3	4500W(1.5HP)	
	4	5600W(2.0HP)	
	5	7100W(2.5HP)	
	6	8000W(3.0HP)	
	7	9000W(3.2HP)	
	8		10000W(4.0HP)
			11200W(4.0HP)
9		12500W(5.0HP)	
		14000W(5.0HP)	
A		16000W(6.0HP)	

■ Network Address Setting



- When V4+, D4+ or V5X outdoor unit set the code to be found address automatically, the new D4+ indoor unit do not need to set the indoor unit address, at this time the outdoor unit will distribute different addresses for indoor units automatically.
- When outdoor unit set the code to be found address non-automatically, all the indoor units must set the system addresses by remote controller first (For the setting system address of indoor unit which has two or more main boards, it has to separate use the display board connected with ten-core connecting wire to set the address for each mainboard).
- When all indoor units are D4+ series indoor unit, the central controlling of indoor unit can be finished in the outdoor unit, and not need to make central control in the indoor unit, the detail please refers to the V4+, D4+, VR4+ or V5X outdoor unit instruction manual;

■ Mainboard codes indication label









SW1 Definition

ON 	<ul style="list-style-type: none"> ● 1 means factory test mode ● 0 means auto addressing mode (default setting)
ON 	<ul style="list-style-type: none"> ● 1 means DC fan is chosen ● 0 means AC fan is chosen
ON 	<ul style="list-style-type: none"> ● 00 means DC fanstatic pressure is 0 (reserved)
ON 	<ul style="list-style-type: none"> ● 01 means DC fanstatic pressure is 1 (reserved)
ON 	<ul style="list-style-type: none"> ● 10 means DC fanstatic pressure is 2 (reserved)
ON 	<ul style="list-style-type: none"> ● 11 means DC fanstatic pressure is 3 (reserved)





J1, J2 Definition

	<ul style="list-style-type: none"> ● without jumper "J1" for auto restart function
	<ul style="list-style-type: none"> ● with jumper "J1" for non-auto restart function
	<ul style="list-style-type: none"> ● reserved



SW2 Definition

ON 	<ul style="list-style-type: none"> ● 00 means shutting down the unit to "stop cold air" at 15°C
ON 	<ul style="list-style-type: none"> ● 01 means shutting down the unit to "stop cold air" at 20°C
ON 	<ul style="list-style-type: none"> ● 10 means shutting down the unit to "stop cold air" at 24°C
ON 	<ul style="list-style-type: none"> ● 11 means shutting down the unit to "stop cold air" at 26°C
ON 	<ul style="list-style-type: none"> ● 00 means the time of stopping TERMAL fan is 4 mintue
ON 	<ul style="list-style-type: none"> ● 01 means the time of stopping TERMAL fan is 8 mintue
ON 	<ul style="list-style-type: none"> ● 10 means the time of stopping TERMAL fan is 12 mintue
ON 	<ul style="list-style-type: none"> ● 11 means the time of stopping TERMAL fan is 16 mintue



SW5 Definition

ON 	<ul style="list-style-type: none"> ● 00 means temp. compensation value is 6°C under heat mode
ON 	<ul style="list-style-type: none"> ● 01 means temp. compensation value is 2°C under heat mode
ON 	<ul style="list-style-type: none"> ● 10 means temp. compensation value is 4°C under heat mode
ON 	<ul style="list-style-type: none"> ● 11 means temp. compensation value is 8°C under heat mode



SW6 Definition

ON 	<ul style="list-style-type: none"> ● 1 means old display panel ● 0 means new display panel
ON 	<ul style="list-style-type: none"> ● 1 means auto air blow under auto mode ● 0 means auto air blow under non-auto mode
ON 	<ul style="list-style-type: none"> ● reserved

SW7 Definition

ON 	<ul style="list-style-type: none"> ● standard configuration
ON 	<ul style="list-style-type: none"> ● last unit of the network

0/1 Definition

ON 	<ul style="list-style-type: none"> ● means 0
ON 	<ul style="list-style-type: none"> ● means 1



CAUTION

- Please adjust the code ENC1 to the suitable position (both system A and B should be adjusted for 450 and 560 indoor unit).
- For 450 unit, two mainboards in the electric control should set the code ENC1 to 8;
- For 560 unit, two mainboards in the electric control should set the code to 9.
- For the same indoor unit, every mainboard must be different indoor unit addresses and network addresses.
- When using central controller to control the indoor unit, please pay attention to the address setting, as the 450 and 560 units have two or more mainboards. We suggest setting the neighbor address for the mainboards in the same indoor unit. When using a central controller for controlling, mainboards in the same unit must be opened and closed at the same time, for avoiding the unexpected incident.

13. TROUBLE SHOOTING

Table.13-1

NO.	Type	Contents	LED Lamp flash	Remarks
1	Malfunction	The evaporator sensor check point is abnormal or room temp. sensor is abnormal.	Run lamp flashes at 2.5Hz.	After the malfunctions disappear, it restores automatically.
2	Malfunction	Indoor/outdoor unit communication is abnormal.	The timer lamp flashes at 2.5Hz.	After the malfunctions disappear, it restores automatically.
3	Malfunction	Condenser sensor check point is abnormal or outdoor temp. sensor is abnormal	All the indoor alarm lamps flash at 0.5Hz.	After the malfunctions disappear, it restores automatically.
4	Malfunction	Water level switch is abnormal	Alarm lamp flashes at 2.5Hz.	If the malfunctions can't be solved in three min. all the indoor alarm lamps flash at 0.5Hz. Turn off the power to restore.
5	Alarm	Mode conflict	Defrost lamp flashes at 2.5Hz.	When the indoor unit turns to heating mode or is turned off, the alarm will disappear.
6	Malfunction	EPPROM error	Defrost lamp flashes at 0.5Hz.	After the malfunctions disappear, it restores automatically.
7	Alarm	The indoor unit without an address when it is first time electrified	Timer lamp and run lamp flash at 2.5Hz together.	After the malfunctions disappear, it restores automatically.

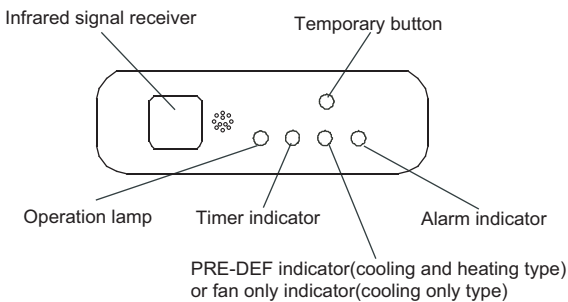

Fig. 13-1

14. INSTALL ELECTRIC THROTTLE PART

- Please refer to the Fig. 4-8 figures to install.

15. INSTALL BRANCH PIPE

For 40KW~56KW models.

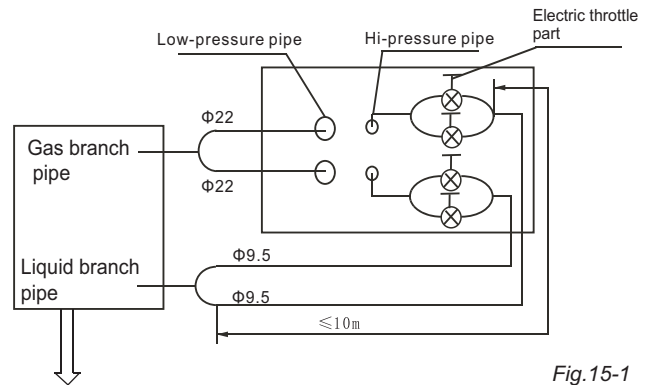

Fig.15-1

The piping diameter please refer to the manual of the outdoor unit you choose.

- Branch Part should be installed in horizontal mode or vertical mode.

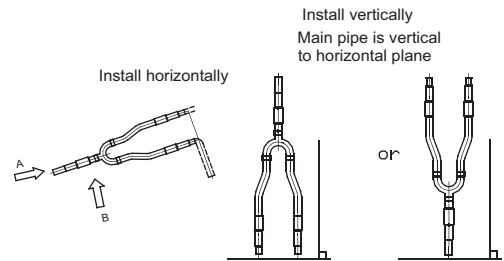

Fig.15-2

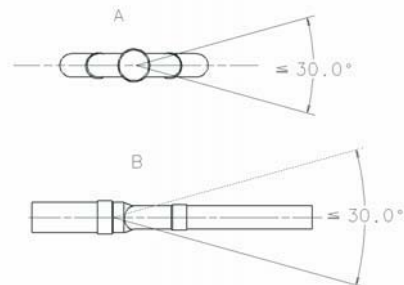

Fig.15-3

16. TEST OPERATION

- The test operation must be carried out after the entire installation has been completed.
- Please confirm the following points before the test operation:
 - The indoor unit and outdoor unit are installed properly.
 - Tubing and wiring are correctly completed.
 - The refrigerant pipe system is leakage-checked.
 - The drainage is unimpeded.
 - The heating insulation works well.
 - The ground wiring is connected correctly.
 - The length of the tubing and the added stop capacity of the refrigerant have been recorded.
 - The power voltage fits the rated voltage of the air conditioner.
 - There is no obstacle at the outlet and inlet of the outdoor and indoor and indoor units
 - The gas-side and liquid-side stop valve are both opened.
 - The air conditioner is pre-heated by turning on the power.
- According to the user's requirement, install the remote controller frame where the remote controller's signal can reach the indoor unit smoothly.
- Test operation

Set the air conditioner under the mode of "COOLING" with the remote controller, and check the following points per the "Owner's Manual" If there is any malfunction, please resolve it through chapter "Troubles And Causes" in the "Owner's Manual".

 - The indoor unit
 - Whether the switch on the remote controller works well.
 - Whether the buttons on the remote controller works well.
 - Whether the air flow louver moves normally.
 - Whether the room temperature is adjusted well.
 - Whether the indicator lights normally.
 - Whether the temporary buttons works well.
 - Whether the drainage is normal.
 - Whether there is vibration or abnormal noise during operation.
 - Whether the air conditioner heats well in the case of the HEATING/COOLING type.
 - The outdoor unit
 - Whether there is vibration or abnormal noise during operation.
 - Whether the generated wind, noise, or condensed water by the air conditioner have influenced your neighborhood.
 - Whether any of the refrigerant is leaked.



CAUTION

Protection function will delay the startup of compressor for 3 minutes in case the unit is turned on immediately after power on or restarted after shutdown.

17. FRESH AIR HARDING UNIT CONFIGURATION INSTRUCTIONS

- For the fresh air machine, a system can be configured for single machine, and not with a fresh air inside the machine to mix and match, otherwise it will cause serious attenuation ability.
- Each model is configured as follows:
 - A 450 matching a 16 HP multiple outer machine;
 - A 560 matching a 20 HP multiple outer machine;



MUNDO  CLIMA[®]



www.mundoclima.com

ASK FOR MORE INFORMATION

Phone: (+34) 93 446 27 81

eMail: info@mundoclima.com

TECHNICAL ASSISTANCE

Phone: (+34) 93 652 53 57