

OUTDOOR UNIT

Installation and
owner's manual

MAXI MVD V5X



CONTENTS

Installation manual	3
Owner's manual	28

INSTALLATION MANUAL

CONTENTS	PAGE
PRECAUTIONS.....	3
CONSTRUCTION CHECKPOINTS.....	4
ACCESSORIES.....	5
OUTDOOR UNIT INSTALLATION.....	6
REFRIGERANT PIPE.....	14
ELECTRIC WIRING.....	21
TRIAL RUN.....	26

1. PRECAUTIONS

Precautions before reading the Installation manual.

- This Installation manual is for the outdoor unit.
- Refer to the indoor unit Installation manual for indoor parts installation.
- Please read the power source unit Installation manual to install the power source unit.
- Please refer to the refrigerant distributor Installation manual to install the refrigerant distributor.

The safety precautions listed here are divided into two categories. In either case, important safety information is listed which must be read carefully.



WARNING

Failure to observe a warning may result in death. The appliance shall be installed in accordance with national wiring regulations.



CAUTION

Failure to observe a caution may result in injury or damage to the equipment.

After completing the installation, make sure that the unit operates properly during the start-up operation. Please instruct the customer on how to operate the unit and keep it trained. Also, inform customers that they should store this Installation manual along with the owner's manual for future reference.



WARNING

- **Be sure only trained and qualified service personnel to install, repair or service the equipment.**
Improper installation, repair, and maintenance may result in electric shocks, short-circuit, leaks, fire or other damage to the equipment.

- **Install according to this installation instructions strictly.**
If installation is defective, it will cause water leakage, electrical shock fire.
- **When installing the unit in a small room, take measures against to keep refrigerant concentration from exceeding allowable safety limits in the event of refrigerant leakage.**
Contact the place of purchase for more information. Excessive refrigerant in a closed ambient can lead to oxygen deficiency.
- **Use the attached accessories parts and specified parts for installation.**
Otherwise, it will cause the set to fall, water leakage, electrical shock fire.
- **Install at a strong and firm location which is able to withstand the set's weight.**
If the strength is not enough or installation is not properly done, the set will drop to cause injury.
- **The appliance shall be installed in accordance with national wiring regulations**
- **The appliance shall not be installed in the laundry.**
- **Before obtaining access to terminals, all supply circuits must be disconnected.**
- **The appliance must be positioned so that the plug is accessible.**
- **The enclosure of the appliance shall be marked by word, or by symbols, with the direction of the fluid flow.**
- **For electrical work, follow the local national wiring standard, regulation and this installation instructions. An independent circuit and single outlet must be used.**
If electrical circuit capacity is not enough or defect in electrical work, it will cause electrical shock fire.
- **Use the specified cable and connect tightly and clamp the cable so that no external force will be acted on the terminal.**
If connection or fixing is not perfect, it will cause heat-up or fire at the connection.
- **Wiring routing must be properly arranged so that control board cover is fixed properly.**
If control board cover is not fixed perfectly, it will cause heat-up at connection point of terminal, fire or electrical shock.
- **If the supply cord is damaged, it must be replaced by the manufacture or its service agent or similarly qualified person in order to avoid a hazard.**
- **An all-pole disconnection device which has at least 3mm separation distance in all pole and a residual current device(RCD)with the rating of above 10mA shall be incorporated in the fixed wiring according to the national rule**
- **When carrying out piping connection, take care not to let air substances go into refrigeration cycle.**
Otherwise, it will cause lower capacity, abnormal high pressure in the refrigeration cycle, explosion and injury.

- **Do not modify the length of the power supply cord or use of extension cord, and do not share the single outlet with other electrical appliances.**
Otherwise, it will cause fire or electrical shock.
- **Carry out the specified installation work after taking into account strong winds, typhoons or earthquakes.**
Improper installation work may result in the equipment falling and causing accidents.
- **The temperature of refrigerant circuit will be high, please keep the interconnection cable away from the copper tube.**
- **The power cord type designation is H07RN-F.**
Equipment complying with IEC 61000-3-12.
- **If the refrigerant leaks during installation, ventilate the area immediately.**
Toxic gas may be produced if the refrigerant comes into the place contacting with fire.
- **After completing the installation work, check that the refrigerant does not leak.**
Toxic gas may be produced if the refrigerant leaks into the room and comes into contact with a source of fire, such as a fan heater, stove or cooker.

- **The appliance is not intended for use by young children or infirm persons without supervision.**
- **Young children should be supervised to ensure that they do not play with the appliance.**
- **Don't install the air conditioner in the following locations:**
 - There is petrolatum existing.
 - There is salty air surrounding (near the coast).
(Except for the models with corrosion-resistant function)
 - There is caustic gas (the sulfide, for example) existing in the air (near a hot spring).
 - The Volt vibrates violently (in the factories).
In buses or cabinets.
In kitchen where it is full of oil gas.
 - There is strong electromagnetic wave existing.
 - There are inflammable materials or gas.
 - There is acid or alkaline liquid evaporating.
 - Other special conditions.
- **The insulation of the metal parts of the building and the air conditioner should comply with the regulation of National Electric Standard.**



CAUTION

- **The cooling&heating indoor unit is applicable for the cooling&heating and the cooling only outdoor unit;the heating capacity of the indoor unit will be effective only when the indoor unit connect to the cooling&heating outdoor unit.**
- **This A/C is a kind of amenity unit. Don't install it at the place where for storing machine, precise instrument, food, plant, animal, artwork or any other special used occasion.**
- **Ground the air conditioner.**
Do not connect the ground wire to gas or water pipes, lightning rod or a telephone ground wire. Incomplete grounding may result in electric shocks.
- **Be sure to install an earth leakage breaker.**
Failure to install an earth leakage breaker may result in electric shocks.
- **Connect the outdoor unit wires , then connect the indoor unit wires.**
You are not allowed to connect the air conditioner with the power source until wiring and piping the air conditioner is done.
- **While following the instructions in this Installation manual, install drain piping in order to ensure proper drainage and insulate piping in order to prevent condensation.**
Improper drain piping may result in water leakage and property damage.
- **Install the indoor and outdoor units, power supply wiring and connecting wires at least 1 meter away from televisions or radios in order to prevent image interference or noise.**
Depending on the radio waves, a distance of 1 meter may not be sufficient enough to eliminate the noise.







2. CONSTRUCTION CHECKPOINTS

- Acceptance and Unpacking
 - After the machine arrives, check whether it is damaged during the shipment. If the surface or inner side of the machine is damaged, submit a written report to the shipping company.
 - Check whether the model, specification and quantity of the equipment conform to the contract.
 - After removing the outer package, please keep the operation instructions well and count the accessories.
- Refrigerant pipe
 - Check the model and name to avoid mistaken installation.
 - An additionally purchased refrigerant distributor (manifold adapter and manifold pipe) must be used for installing the refrigerant pipes.
 - The refrigerant pipes must have the specified diameter. Nitrogen of a certain pressure must be filled into the refrigerant pipe before welding.
 - The refrigerant pipe must undergo heat insulation treatment.
 - After the refrigerant pipe is installed completely, the indoor unit cannot be powered on before performing the airtight test and creating a vacuum. The gas-side and liquid-side pipes must undergo the airtight test and vacuum extraction.
 - Airtight test
The refrigerant pipe must undergo the airtight test [with 3.9 MPa(40kgf/cm²) nitrogen].

- Creating a vacuum
 - Be sure to use the vacuum pump to create a vacuum of the connective pipe at the gas side and liquid side concurrently.
- Refrigerant replenishment
 - If the length is greater than the reference pipe, the refrigerant replenishment quantity for each system should be calculated through the formula obtained according to the actual length of pipe.
 - Record the refrigerant replenishment quantity, actual length of pipe and the height difference of the indoor & outdoor unit onto the operation confirmation table of the outdoor unit in advance for future reference.
- Electric wiring
 - Select the power supply capacity and wire size according to the design manual. The power cable of the air conditioner is generally thicker than the power cable of the motor.
 - In order to prevent misoperation of the air conditioner, do not interleave or entwine the power cable with the connection wires (low-voltage wires) of the indoor/outdoor unit.
 - Power on the indoor unit after performing the airtight test and making a vacuum.
 - For details of setting the address of the outdoor unit, see Outdoor unit address bits.
- Trial run
 - Before operation, remove the six pieces of PE foaming which are used at the rear of the unit for protecting the condenser. Be careful not to damage the fin. Otherwise, the heat exchange performance may be affected.
 - Perform the trial run only after the outdoor unit has been powered on for over 24 hours.

3. ACCESSORIES

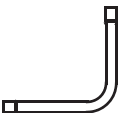
Table.3-1

Name	All of units	Outline	Function
Outdoor unit installation and owner's manual	1		Be sure to deliver it to the customer
Screw bag (accessory)	1		For maintenance
Slot type screwdriver of dialing	1		For dialing of individual indoor unit
90° mouting elbow	1		For connecting pipes
Seal plug	8		For pipe cleaning
Connective pipe accessory	3		For connecting pipes
Matched resistance (network matched wire group)	2		Enhance stability of communication
Cable clip kit	1(Optional)		For grooving the power wire

4. OUTDOOR UNIT INSTALLATION

4.1 Outdoor unit combination

Table.4-1

(HP) Outdoor unit capacity Combination way (HP)	8	10	12	14	16	18	20	22	Max Qty.of indoor unit	Max recommended Qty. of indoor unit
8	●								13	7
10		●							16	9
12			●						20	11
14				●					23	13
16					●				26	15
18						●			29	16
20							●		33	18
22								●	36	20
24			●●						39	22
26		●			●				43	24
28		●				●			46	26
30		●					●		50	27
32		●						●	53	29
34			●					●	56	31
36						●●			59	32
38					●			●	63	35
40						●		●	64	36
42							●	●	64	38
44								●●	64	38
46			●●					●	64	38
48		●			●			●	64	38
50		●				●		●	64	38
52		●					●	●	64	38
54		●						●●	64	38
56			●					●●	64	40
58						●●		●	64	40
60					●			●●	64	40
62						●		●●	64	40
64							●	●●	64	40
66								●●●	64	40
68			●●					●●	64	44
70		●			●			●●	64	44
72		●				●		●●	64	44
74		●					●	●●	64	44
76		●						●●●	64	44
78			●					●●●	64	48
80						●●		●●	64	48
82					●			●●●	64	48
84						●		●●●	64	48
86							●	●●●	64	48
88								●●●●	64	48



CAUTION

- When all of the indoor units operate simultaneously in the system, the total capacity of the indoor units should less than or equal to the combined capacity of outdoor units. Otherwise overload operating will occur when working in a bad working condition or narrow space.
- When all of the indoor units don't operate simultaneously in the system, it is allowed for maximum total capacity of the indoor units is 130% of the combined capacity of outdoor units.
- If the system is used in cold environment (ambient temperature is under -10°C) or in high heat overloading condition, the total capacity of the indoor units should less than the combined capacity of outdoor units.

4.2 Dimension of outdoor unit

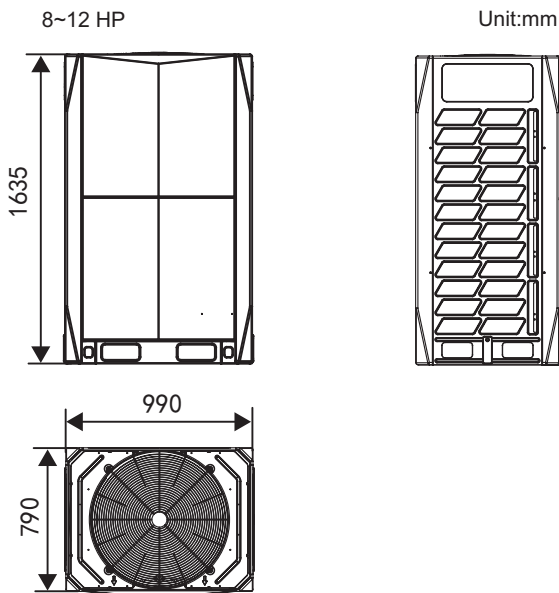

Fig.4-1

The figure shown above is for reference only, the specific panel shall prevail.

14~22 HP

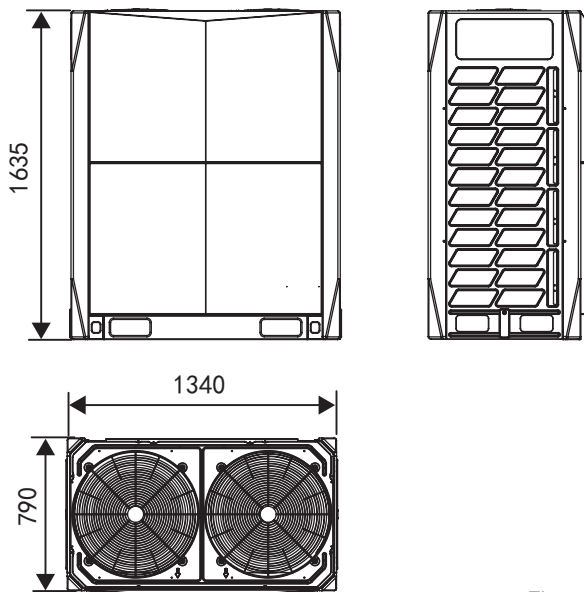

Fig.4-2

The figure shown above is for reference only, the specific panel shall prevail.

4.3 Selecting installation position

- Ensure that the outdoor unit is installed in a dry, well-ventilated place.
- Ensure that the noise and exhaust ventilation of the outdoor unit do not affect the neighbors of the property owner or the surrounding ventilation.
- Ensure that the outdoor unit is installed in a well-ventilated place that is possibly closest to the indoor unit.
- Ensure that the outdoor unit is installed in a cool place without direct sunshine exposure or direct radiation of high-temp heat source.
- Do not install the outdoor unit in a dirty or severely polluted place, so as to avoid blockage of the heat exchanger in the outdoor unit.
- Do not install the outdoor unit in a place with oil pollution or full of harmful gases such as sulfurous gas.
- Do not install the outdoor unit in a place surrounded by salty air. (Except for the models with corrosion-resistant function.)

4.4 Base for outdoor unit

- A solid, correct base can:
 - Avoid the outdoor unit from sinking.
 - Avoid the abnormal noise generated due to base.
- Base types
 - Steel structure base
 - Concrete base (see the figure below for the general making method)

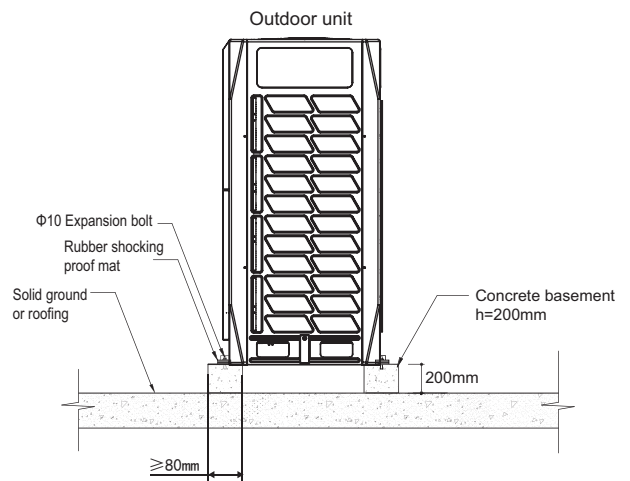

Fig.4-3



CAUTION

- The key points to make basement:
 - The master unit's basement must be made on the solid concrete ground . Refer to the structure diagram to make concrete basement in detail, or make after field measurements.
 - In order to ensure every point can contact equality, the basement should be on completely level.

- If the basement is placed on the roofing, the detritus layer isn't needed, but the concrete surface must be flat. The standard concrete mixture ratio is cement 1/ sand 2/ carpolite 4, and add $\Phi 10$ strenthen reinforcing steel bar, the surface of the cement and sand plasm must be flat, border of the the basement must be chamfer angle.
- Before construct the unit base, please ensure the base is directly supporting the rear and front folding edges of the bottom panel vertically, for the reason of these edges are the actual supported sites to the unit.
- In order to drain off the seeper around the equipment, a discharge ditch must be setup around the basement.
- Please check the affordability of the roofing to ensure the load capacity.
- When piping from the bottom of the unit, the base height should no less than 200mm.

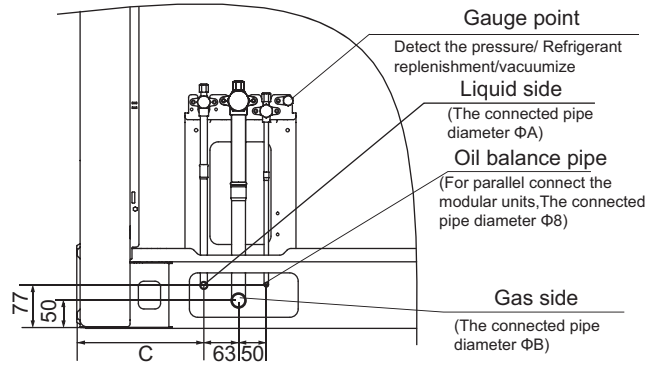

Fig.4-5.1 R amplification

■ Position illustration of screw bolt (Unit: mm)

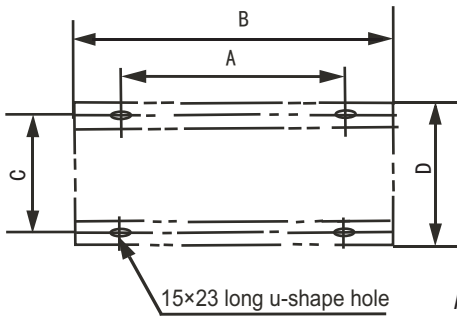

Fig.4-4

Table.4-2 Unit: mm

HP SIZE	8, 10, 12	14, 16, 18, 20, 22
A	740	1090
B	990	1340
C	723	723
D	790	790

Table.4-3 Unit: mm

HP SIZE	8, 10	12	14, 16	18, 20, 22
A	12,7 (1/2")	15,9 (5/8")	15,9 (5/8")	19,1 (3/4")
B	25,4 (1")	28,6 (1 1/8")	31,8 (1 1/4")	31,8 (1 1/4")
C	229	229	244	244

4.5 Outdoor units' placement sequence & master and slave units' settings

A system, which provide with more than two outdoor units, will be set as the followings method: The outdoor units in this system should place sequentially from the large to the small capacity; the largest capacity outdoor unit must be mounted at the first branch joint site; and set the largest capacity outdoor unit address as the master Unit, while the other setting as the Slave Unit. Take 48HP (composed by 10HP, 16HP and 22HP) as an example:

- 1) Place the 22HP at a side of the first branch joint site.
- 2) Place the unit from the large capacity to the small (See the detail placement illustration)
- 3) Set 22HP as the main unit, while the 16HP and the 10HP as the aux. unit.

■ Centering position illustration of each connective pipe (Unit: mm)

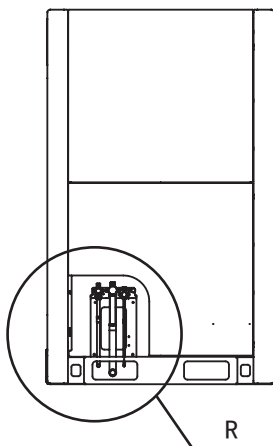

Fig.4-5

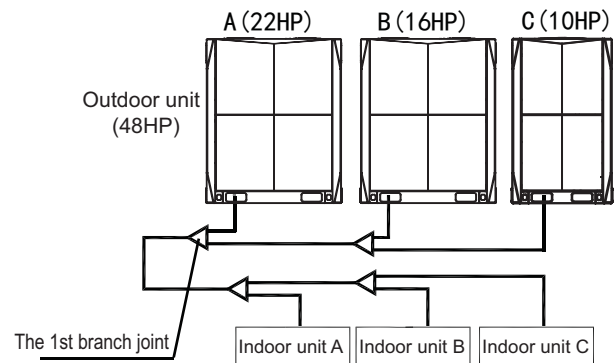
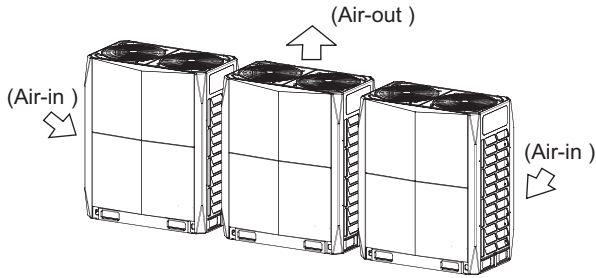

Fig.4-6

4.6 Installation space for outdoor unit

- Ensure enough space for maintenance. The modules in the same system must be on the same height. (Fig.4-7)
- When installing the unit, leave a space for maintenance shown in Fig.4-8. Install the power supply at the side of the outdoor unit. For installation procedure, see the power supply device Installation manual.
- In case any obstacles exist above the outdoor unit, refer to Fig.4-13.



Installation and maintenance surface Fig.4-7

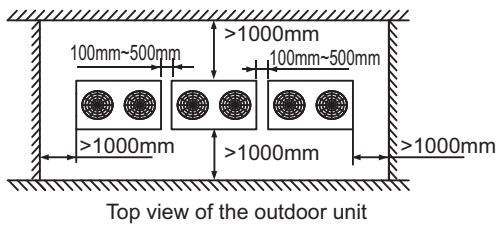

Fig.4-8

4.7 Layout

- When the outdoor unit is higher than the surrounding obstacle

- One row

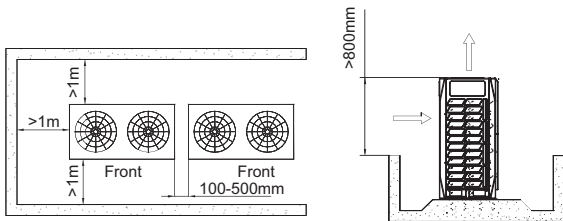

Fig.4-9

- Two rows

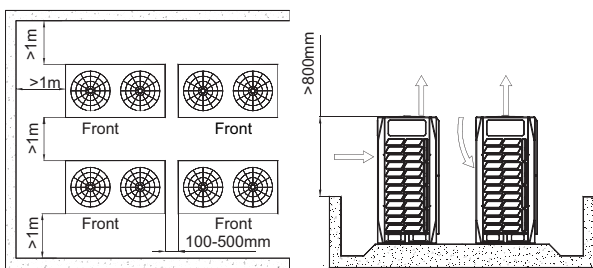

Fig.4-10

- More than two rows

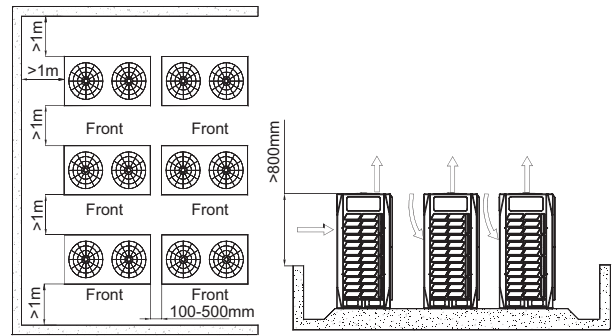

Fig.4-11

- When the outdoor unit is lower than the surrounding obstacle, refer to the layout used when the outdoor unit is higher than the surrounding obstacle. However, to avoid cross connection of the outdoor hot air from affecting the heat exchange effect, please add an air director onto the exhaust hood of the outdoor unit to facilitate heat dissipation. See the figure below. The height of the air director is HD (namely H-h). Please make the air director on site.

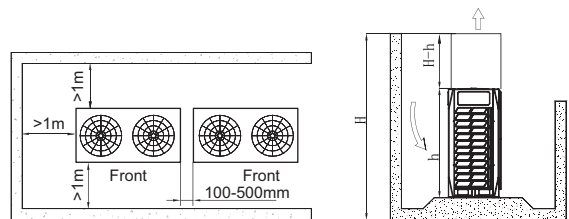
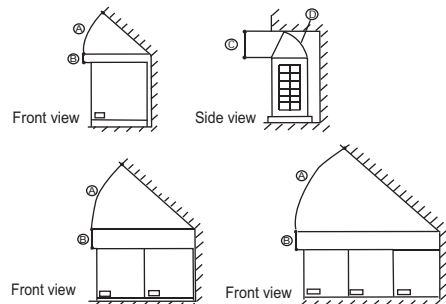

Fig.4-12

- If miscellaneous articles are piled around the outdoor unit, such articles must be 800mm below the top of the outdoor unit. Otherwise, a mechanic exhaust device must be added.



- (A) >45°
- (B) >300mm
- (C) >1000mm
- (D) Airflow deflector

Fig.4-13

4.8 Set the snow-proof facility

- In snowy areas, facilities should be installed to prevent snow. (See the figure below) (defective facilities may cause malfunction.) Please lift the bracket higher and install snow shed at the air inlet and air outlet.

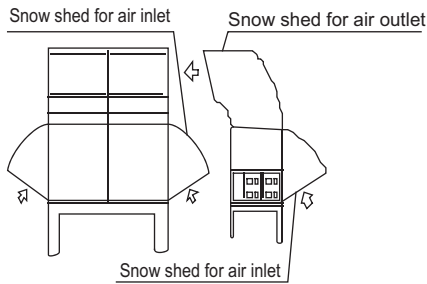

Fig.4-14

4.9 Description of panel dismantling

- First, dismantling the frontal left and right upright posts: dismantle the 4 screws of the left and right upright posts. (Fig 4-15), and then rotate the upright posts and uplift them for around 2mm(Fig 4-16 and Fig 4-17) to remove the left and right upright posts.
- Dismantling the upper panel: dismantle 4 screws of the upper panel on left and right sides(Fig 4-18) and then uplift it for 3mm to remove the upper panel.

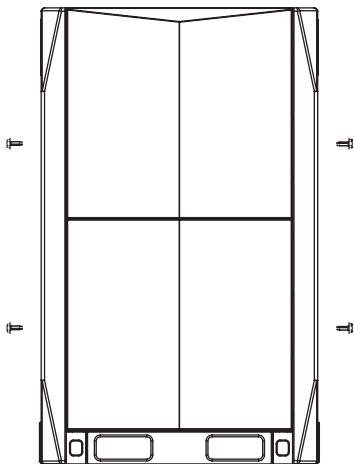

Fig.4-15

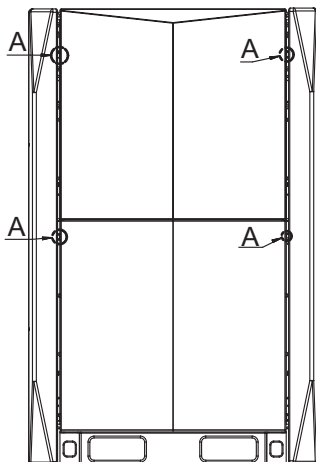

Fig.4-16

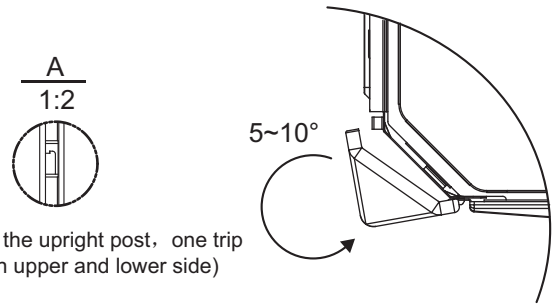

Fig.4-17

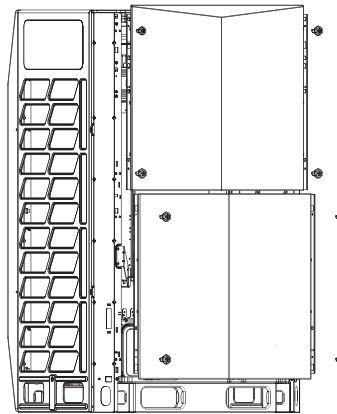

Fig.4-18

The figure shown above is for reference only, the specific panel shall prevail.

4.10 Explanation of valve

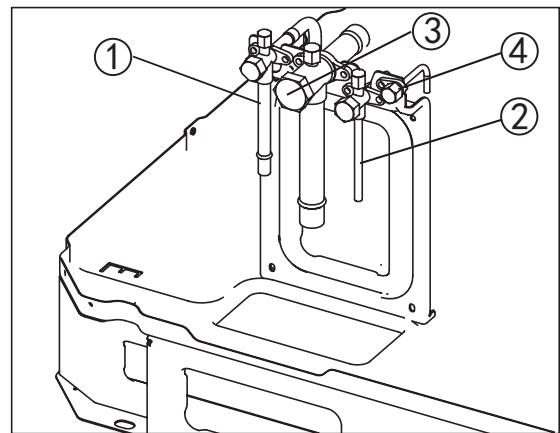

Fig.4-19

①	Liquid side ball valve
②	Connecting Oil balance pipe (※)
③	Gas side ball valve
④	needle valve (For pressure test and refrigerant filling)

※ Note: For a single module that is not necessary to connect with oil balance pipe.

4.11 Mount the air deflector

(If the static pressure of outdoor unit is over 20Pa, The unit need be customized.)

■ 8~12HP Installation illustration

Example A

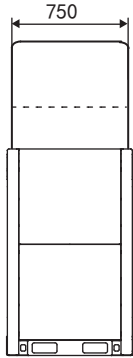
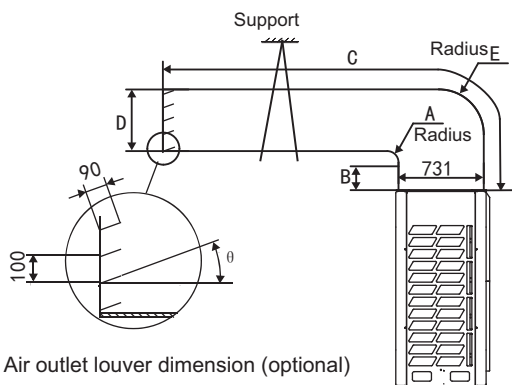

Fig.4-20

Table.4-5 Unit: mm

A	$A \geq 300$
B	$B \geq 250$
C	$C \leq 3000$
D	$731 \leq D \leq 770$
E	$E = A + 731$
θ	$\theta \leq 15^\circ$



Air outlet louver dimension (optional)

Fig.4-21

Example B

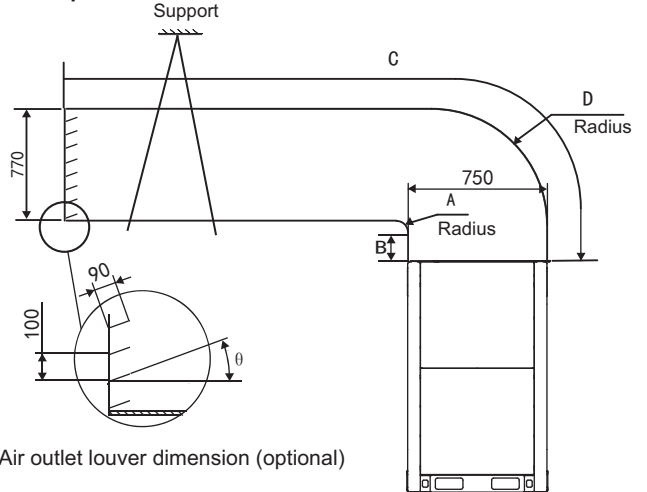

Air outlet louver dimension (optional)

Fig.4-24

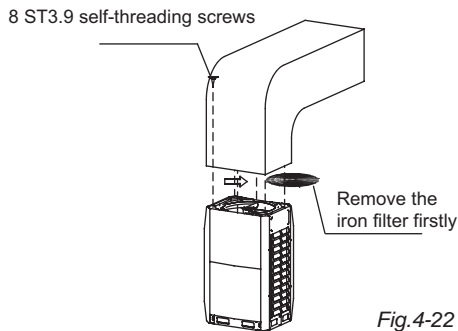

Fig.4-22

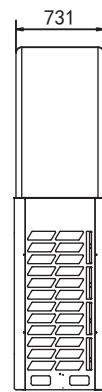

Fig.4-25

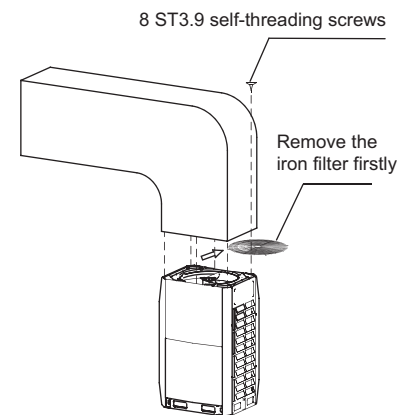

Fig.4-26

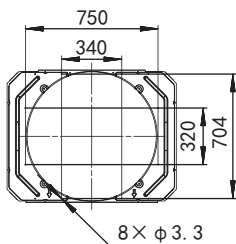

Fig.4-23

A	$A \geq 300$
B	$B \geq 250$
C	$C \leq 3000$
D	$D = A + 750$
θ	$\theta \leq 15^\circ$

Table.4-4

Static pressure	Remark
0Pa	Factory default
0~20Pa	Remove wire meshes and connect to the wind duct which is less than 3 meters
Above 20Pa	Customization need

■ 14~22HP Installation illustration

Example A

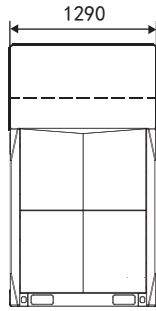

Fig.4-27

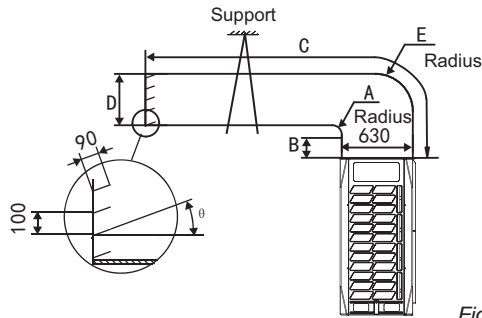

Fig.4-28

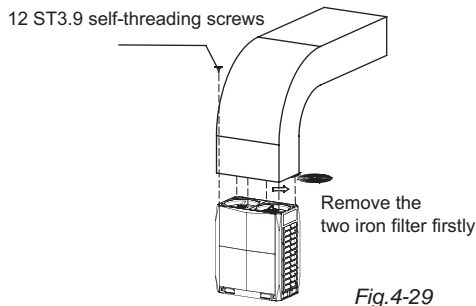

Fig.4-29

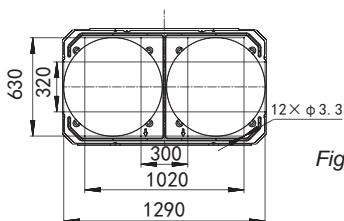

Fig.4-30

A	$A \geq 300$
B	$B \geq 250$
C	$C \leq 3000$
D	$630 \leq D \leq 660$
E	$E = A + 630$
θ	$\theta \leq 15^\circ$

Table.4-5

Static pressure	Remark
0Pa	Factory default
0~20Pa	Remove wire meshes and connect to the wind duct which is less than 3 meters
Above 20Pa	Customization need

Example B

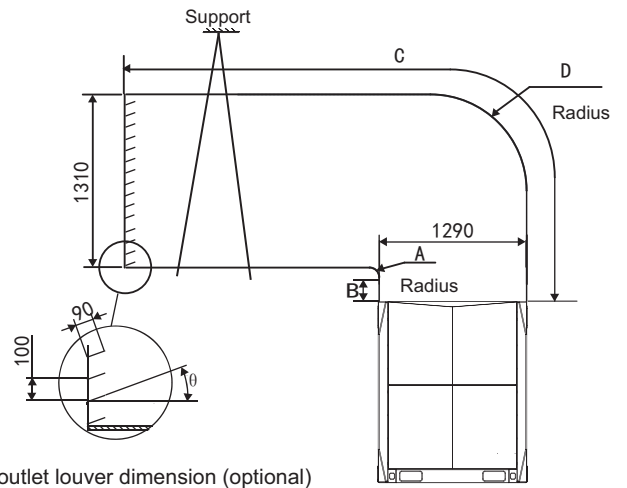

Air outlet louver dimension (optional)

Fig.4-31



Fig.4-32

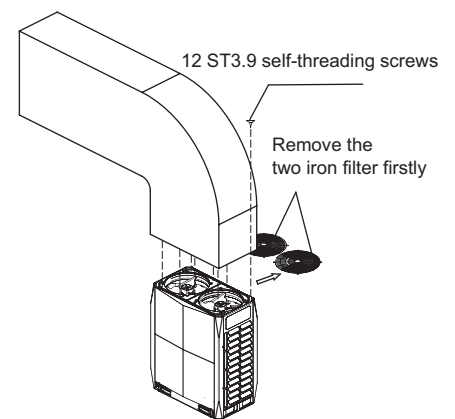

Fig.4-33

A	$A \geq 300$
B	$B \geq 250$
C	$C \leq 3000$
D	$D = A + 1290$
θ	$\theta \leq 15^\circ$



NOTE

- Before install the air deflector, please ensuring the mesh enclosure has been took off, otherwise the air supply efficiency would be block down.
- Once mounting the shutter to the unit, air volume, cooling (heating) capacity and efficiency would be block down, this affection enhance along with the angle of the shutter. Thus, we are not recommend you to mount the shutter, if necessary in use, please adjust the angle of shutter no larger than 15°.
- Only one bending site to be allowed in the air duct (see as above figure), otherwise, misoperation may led out.
- Install the flexible connector between the unit and the air pipe, for avoiding to produce vibration noise

■ Curve diagram of static pressure, air flow volumn.

8HP,10HP

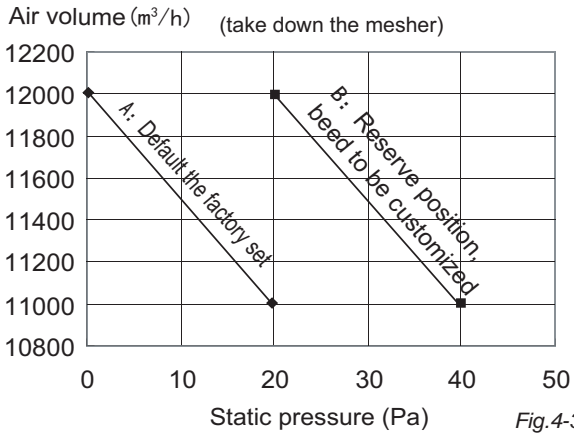

18HP

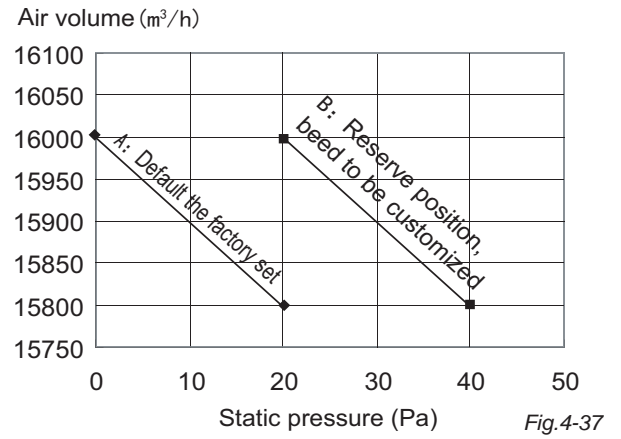

12HP

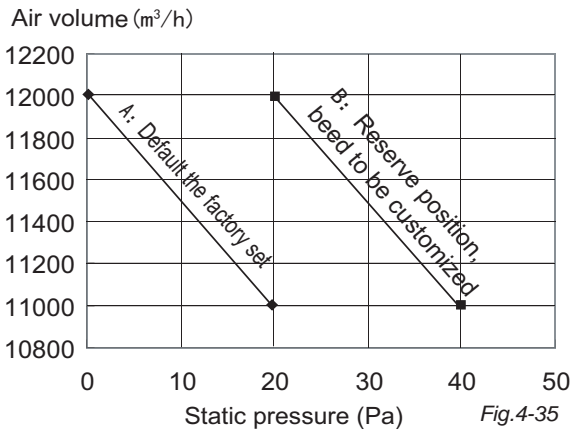

20HP、22HP

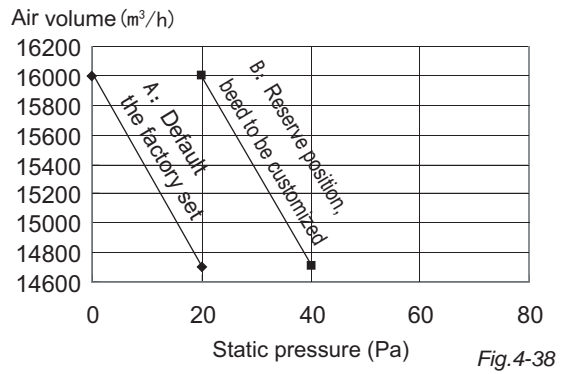

14HP,16HP

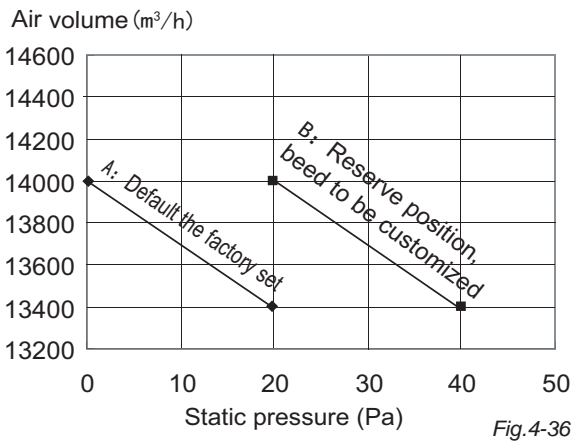

5. REFRIGERANT PIPE

5.1 Length and drop height permitted of the refrigerant piping

Table.5-1

		Permitted value	Piping(refer to Fig.5-1)
Pipe length	Total pipe length (Total extended length)	1000m (Please refer to the caution 5 of conditions 2)	$L_1 + (L_2 + L_3 + L_4 + L_5 + L_6 + L_7 + L_8 + L_9 + L_{10} + L_{11} + L_{12}) \times 2 + a + b + c + d + e + f + g + h + i + j + k + l + m$
	Maximum piping (L)	Actual length	$L_1 + L_7 + L_8 + L_9 + L_{10} + i$ (Pipe diameter requirements, please refers to table. 5-4 or 5-5)
		Equivalent length (Please refer to caution 1)	200m
Pipe (between the farthest indoor unit and first branch joint) length		40/90*m (Please refer to caution 5)	$L_7 + L_8 + L_9 + L_{10} + i$
Drop height	Indoor unit-outdoor unit drop height	Outdoor unit up	(Please refer to caution 3)
		Outdoor unit down	(Please refer to caution 4)
	Indoor unit to indoor unit drop height		30m

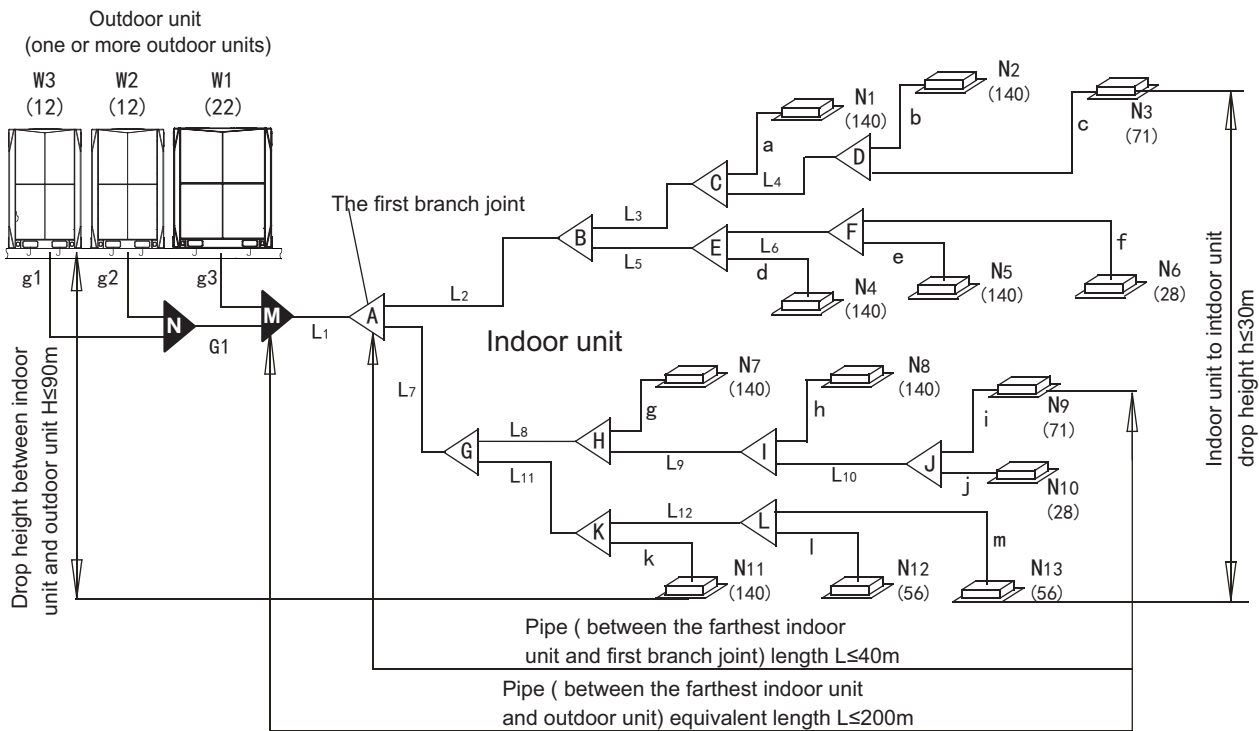

*1.Level difference above 90m are not supported by default but are available on request for customized.(if the outdoor unit is above the indoor unit.)

Fig.5-1

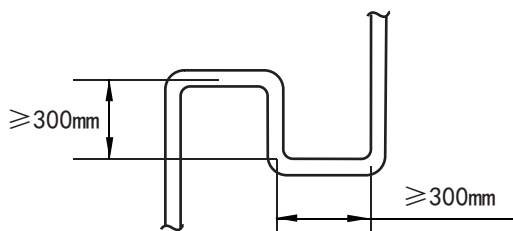

Fig.5-2



CAUTION

1. The reduced length of the branch joint is the 0.5m of the equivalent length.
2. The inner units should as equal as possible to be installed in the both sides of the U-shape branch joint.
3. When the outdoor unit is on the top position and the difference of level is over 20m, it is recommended that set a oil return bend every 10m in the air pipe of the main pipe, the specification of the oil return bend refers to Fig.5-2.
4. When the outdoor unit is on the low position, $H \geq 40m$, the liquid pipe of the main pipe need to increase one size.
5. The allowable length of the first branch joint which connected to the indoor unit should be equal to or shorter than 40m.
But when the following conditions are all metted, the allowable length can extended to 90m.

Conditions
1. It is needed to increase all the pipe diameters of the the main distribution pipe which between the first and the last branch joint assembly. (Please change the pipe diameter at field) If the pipe diameter of the main slave pipe is the same as the main pipe, then it is not needed to be increased.
Examples
<ul style="list-style-type: none"> ■ N9 $L_7+L_8+L_9+L_{10}+i \leq 90m$, L2, L3, L4, L5, L6, L7, L8, L9, L10, L11, L12 Need to increase the pipe diameter of the distribution pipe. ■ Increasing size as the following $\phi 9.5 \rightarrow \phi 12.7$ $\phi 12.7 \rightarrow \phi 15.9$ $\phi 15.9 \rightarrow \phi 19.1$ $\phi 19.1 \rightarrow \phi 22.2$ $\phi 22.2 \rightarrow \phi 25.4$ $\phi 25.4 \rightarrow \phi 28.6$ $\phi 28.6 \rightarrow \phi 31.8$ $\phi 31.8 \rightarrow \phi 38.1$ $\phi 38.1 \rightarrow \phi 41.2$ $\phi 41.2 \rightarrow \phi 44.5$ $\phi 44.5 \rightarrow \phi 54.0$
Conditions
2. When counting the total extended length, the actual length of above distribution pipes must be doubled. (Expect the main pipe and the distribution pipes which no need to be increased.) $L_1 + (L_2+L_3+L_4+L_5+L_6+L_7+L_8+L_9+L_{10}+L_{11}+L_{12}) \times 2 + a+b+c+d+e+f+g+h+i+j+k+l+m \leq 1000m$
Examples
Reference Figure. 5-1
Conditions
3. The length from the indoor unit to the nearest branch joint assembly $\leq 20m$ $a, b, c, \dots m \leq 20m$ (Pipe diameter requirements, please refers to table .5-9)
Examples
Reference Figure .5-1
Conditions
4. The distance difference between [the outdoor unit to the farthest indoor unit] and [the outdoor unit to the nearest indoor unit] is $\leq 40m$. The farthest indoor unit N9 The nearest indoor unit N1 $(L_1+L_7+L_8+L_9+L_{10}+i) - (L_1+L_2+L_3+a) \leq 40m$

Examples
Reference Figure. 5-1

5.2 Size of joint pipes for indoor unit

Table.5-2

Pipe name	Code (refer to Fig.5-1)
Main pipe	L1
Indoor unit main pipe	L2, L3, L4, L5,... L12
Indoor unit aux. pipe	a, b, c, d,... m
Indoor unit branch joint assembly	A, B, C, D, E, F, G, H, I, J, K, L
Outdoor unit branch joint assembly	M, N, O
Outdoor unit connective pipe	g1, g2, g3, G1, G2

Table.5-3 Size of joint pipes for 410A indoor unit (L2 ~ L12) and(B ~ L)

Capacity of indoor unit A($\times 100W$)	Size of main pipe(mm)		
	Gas side	Liquid side	Available branch joint
$A < 166$	$\Phi 15.9$	$\Phi 9.5$	FQZHN-01D
$166 \leq A < 230$	$\Phi 19.1$	$\Phi 9.5$	FQZHN-01D
$230 \leq A < 330$	$\Phi 22.2$	$\Phi 9.5$	FQZHN-02D
$330 \leq A < 460$	$\Phi 28.6$	$\Phi 12.7$	FQZHN-03D
$460 \leq A < 660$	$\Phi 28.6$	$\Phi 15.9$	FQZHN-03D
$660 \leq A < 920$	$\Phi 31.8$	$\Phi 19.1$	FQZHN-03D
$920 \leq A < 1350$	$\Phi 38.1$	$\Phi 19.1$	FQZHN-04D
$1350 \leq A < 1800$	$\Phi 41.2$	$\Phi 22.2$	FQZHN-05D
$1800 \leq A$	$\Phi 44.5$	$\Phi 25.4$	FQZHN-05D

e.x.1: Refer to Fig.5-3, the capacity of downstream units to L4 is $140+71=211$, the gas pipe for L2 is $\Phi 19.1$, liquid pipe is $\Phi 9.5$.

5.3 Select the refrigerant piping type

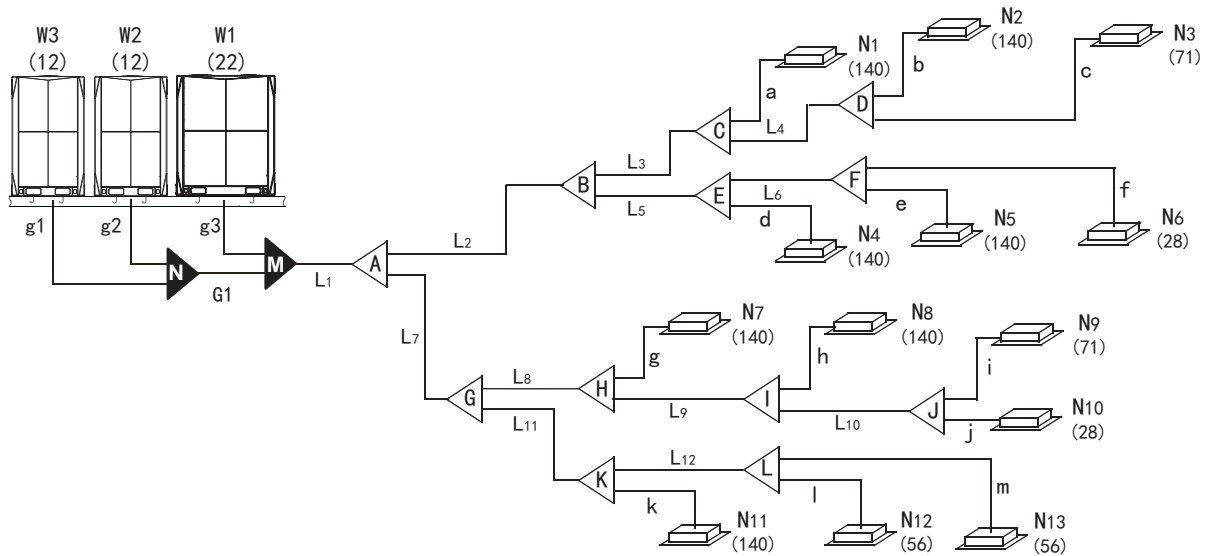

Fig.5-3

5.4 Size of joint pipes for outdoor unit

Base on the following tables, select the diameters of the outdoor unit connective pipes. In case of the main accessory pipe large than the main pipe, take the large one for the selection.

Example: parallel connect with the three outdoor units 12+12+22 (the total capacity is 46HP), all indoor units total capacity is 1290, provided that the equivalent length of all pipes are $\geq 90m$, according to the Table. 5-5 the main pipe diameter are $\Phi 38.1/\Phi 22.2$; in according to all indoor unit capacity 1290, we could find out the master unit diameter is $\Phi 38.1/\Phi 19.1$ base on Table.5-3. Take the large one for the selection, we final confirm the main pipe diameter is $\Phi 38.1/\Phi 22.2$.

Table.5-4 Size of joint pipes for 410A outdoor unit (L1) and (A)

Model	When the equivalent length of all liquid pipes < 90m, the size of main pipe(mm)		
	Gas side	Liquid side	The 1st branch joint
8HP	$\Phi 22.2$	$\Phi 9.53$	FQZHN-02D
10HP	$\Phi 22.2$	$\Phi 9.53$	FQZHN-02D
12~14HP	$\Phi 25.4$	$\Phi 12.7$	FQZHN-02D
16HP	$\Phi 28.6$	$\Phi 12.7$	FQZHN-03D
18~22HP	$\Phi 28.6$	$\Phi 15.9$	FQZHN-03D
24HP	$\Phi 28.6$	$\Phi 15.9$	FQZHN-03D
26~34HP	$\Phi 31.8$	$\Phi 19.1$	FQZHN-03D
36~50HP	$\Phi 38.1$	$\Phi 19.1$	FQZHN-04D
52~66HP	$\Phi 41.2$	$\Phi 22.2$	FQZHN-05D
68~88HP	$\Phi 44.5$	$\Phi 25.4$	FQZHN-05D

Table.5-5 Size of joint pipes for 410A outdoor unit (L1) and (A)

Model	When the equivalent length of all liquid pipes $\geq 90m$, the size of main pipe(mm)		
	Gas side	Liquid side	The 1st branch joint
8HP	$\Phi 22.2$	$\Phi 12.7$	FQZHN-02D
10HP	$\Phi 25.4$	$\Phi 12.7$	FQZHN-02D
12~14HP	$\Phi 28.6$	$\Phi 15.9$	FQZHN-03D
16HP	$\Phi 31.8$	$\Phi 15.9$	FQZHN-03D
18~22HP	$\Phi 31.8$	$\Phi 19.1$	FQZHN-03D
24HP	$\Phi 31.8$	$\Phi 19.1$	FQZHN-03D
26~34HP	$\Phi 38.1$	$\Phi 22.2$	FQZHN-04D
36~50HP	$\Phi 38.1$	$\Phi 22.2$	FQZHN-04D
52~66HP	$\Phi 44.5$	$\Phi 25.4$	FQZHN-05D
68~88HP	$\Phi 54.0$	$\Phi 25.4$	FQZHN-06D

5.5 Branch pipes for outdoor unit

Table.5-6 Outdoor pipes (g1, g2, g3, g4, G1, G2)

Model	Outdoor unit pipe connective opening dimension(mm)	
	Gas side	Liquid side
8~12HP	$\Phi 25.4$	$\Phi 12.7$
14~22HP	$\Phi 31.8$	$\Phi 15.9$

5.6 Branch pipes for indoor unit

Base on Table.5-7 and Table.5-8 select the multi connecting pipes of outdoor unit. Before installation, please read the Outdoor Unit branch joint Installation Manual carefully.

Table.5-7 Outdoor unit multi-connective pipe assembly (Illustration)

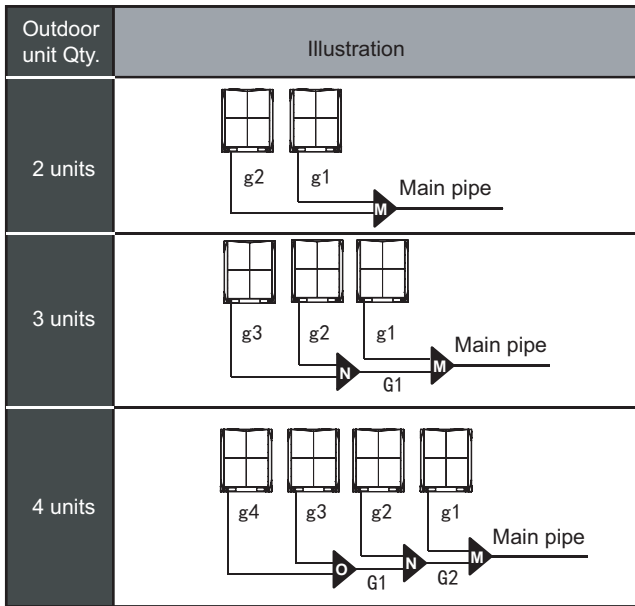

Table.5-8 Outdoor unit multi-connective pipe assembly (M, N, O)

Outdoor unit Qty.	Outdoor unit connective pipe diameter	Parallel connect with the branch joint assembly	Main pipe
2 units	g1, g2: 8~12HP: $\Phi 25.4/\Phi 12.7$; 14~22HP: $\Phi 31.8/\Phi 15.9$	M: FQZHW-02N1D	Refer to Table. 5-4 or 5-5 for main pipe dimension
3 units	g1, g2, g3: 8~12HP: $\Phi 25.4/\Phi 12.7$; 14~22HP: $\Phi 31.8/\Phi 15.9$; G1: $\Phi 38.1/\Phi 19.1$	M+N: FQZHW-03N1D	
4 units	g1, g2, g3, g4: 8~12HP: $\Phi 25.4/\Phi 12.7$; 14~22HP: $\Phi 31.8/\Phi 15.9$; G1: $\Phi 38.1/\Phi 19.1$; G2: $\Phi 41.2/\Phi 22.2$	M+N+O: FQZHW-04N1D	

Note: The pipe assemblies in above table is special for this model, must be purchased separately.

5.7 Example

- Take (22+12+12) HP that composed by three modules as an example to clarify the pipe selection.
- Take Fig.5-4 as an example. Provided that the equivalent length of all pipes in this system is larger than 90m.

Table.5-9

Unit: mm

Indoor unit capacity A($\times 100W$)	When branch joint's length $\leq 10m$		When branch joint's length $> 10m$	
	Gas side	Liquid side	Gas side	Liquid side
$A \leq 45$	$\Phi 12.7$	$\Phi 6.4$	$\Phi 15.9$	$\Phi 9.5$
$A \geq 56$	$\Phi 15.9$	$\Phi 9.5$	$\Phi 19.1$	$\Phi 12.7$

- A The branch joint at the inside of the unit.
There are a~m branch joints at the inside of the unit, the branch joint diameter should be select as per Table. 5-9.
- B Main pipe at the inside the unit (Refer to Table. 5-3)
- The main pipe L4 with N2, N3 downstream indoor units that total capacity is $140+71=211$, the pipe L4 diameter is $\Phi 19.1/\Phi 9.5$, this select FQZHN-01D for the branch joint D.
 - The main pipe L3 with N1~N3 downstream indoor units that total capacity is $140 \times 2 + 71 = 351$, the pipe L3 diameter is $28.6/12.7$, this select FQZHN-03D for the branch joint C.
 - The main pipe L6 with N5, N6 downstream indoor units that total capacity is $140+28=168$, the pipe L4 diameter is $19.1/9.5$, this select FQZHN-01D for the branch joint F.
 - The main pipe L5 with N4~N6 downstream indoor units that total capacity is $140 \times 2 + 28 = 308$, the pipe L5 diameter is $22.2/9.5$, this select FQZHN-02D for the branch joint E.
 - The main pipe L2 with N1~N6 downstream indoor units that total capacity is $140 \times 4 + 71 + 28 = 659$, the pipe L2 diameter is $28.6/15.9$, thus select FQZHN-03D for the branch joint B.
 - The main pipe L10 with N9, N10 downstream indoor units that total capacity is $71+28=99$, the pipe L10 diameter is $15.9/9.5$, this select FQZHN-01D for the branch joint J.
 - The main pipe L9 with N8~N10 downstream indoor units that total capacity is $140+71+28=239$, the pipe L9 diameter is $22.2/9.5$, this select FQZHN-02D for the branch joint I.
 - The main pipe L8 with N7~N10 downstream indoor units that total capacity is $140 \times 2 + 71 + 28 = 379$, the pipe L8 diameter is $28.6/12.7$, this select FQZHN-03D for the branch joint H.
 - The main pipe L12 with N12, N13 downstream indoor units that total capacity is $56 \times 2 = 112$, the pipe L12 diameter is $15.9/9.5$, this select FQZHN-01D for the branch joint L.
 - The main pipe L11 with N11~N13 downstream indoor units that total capacity is $140+56 \times 2 = 252$, the pipe L11 diameter is $22.2/9.5$, this select FQZHN-02D for the branch joint K.
 - The main pipe L7 with N7~N13 downstream indoor units that total capacity is $140 \times 3 + 71 + 56 \times 2 + 28 = 631$, the pipe L7 diameter is $28.6/15.9$, this select FQZHN-03D for the branch joint G.
 - The branch joint A with N1~N13 downstream indoor units that total capacity is $140 \times 7 + 71 \times 2 + 56 \times 2 + 28 \times 2 = 1290$, this select FQZHN-04D for the branch joint A.
- C The main pipe L1 with the three outdoor units $12+12+22$ (the total capacity is 46HP), all indoor units total capacity is 1290, provided that the equivalent length of all pipes are $\geq 90m$, according to the Table. 5-5 the main pipe diameter are $38.1/22.2$; in according to all indoor unit capacity 1290, we could find out the master unit diameter is $38.1/19.1$ base on Table. 5-3. Take the large one for the selection, we final confirm the main pipe diameter is $38.1/22.2$.

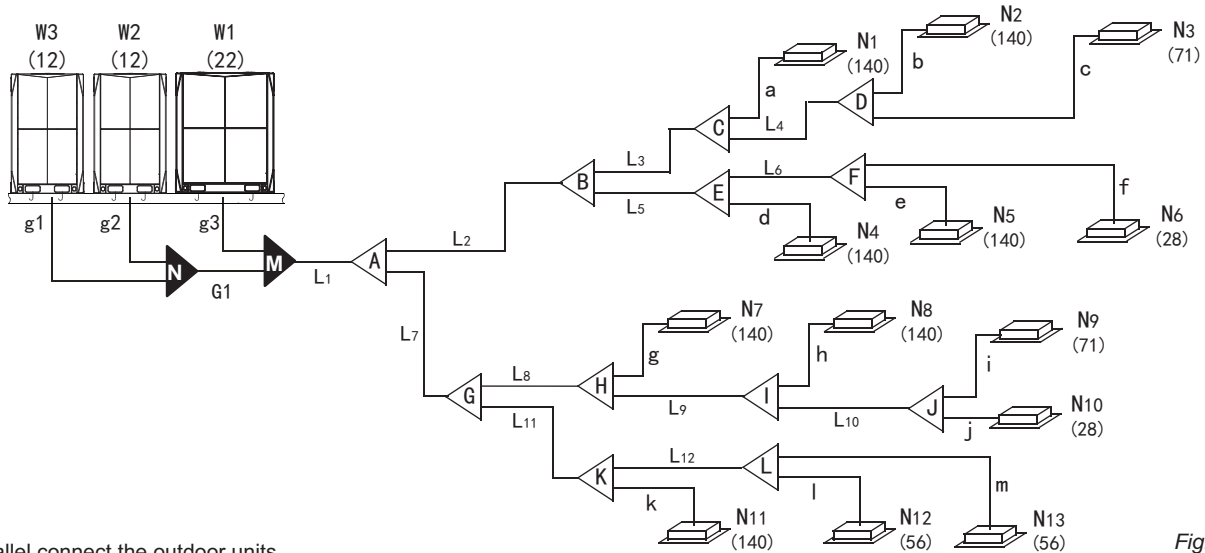

Fig.5-4

D Parallel connect the outdoor units

- 1) The outdoor unit linked by Pipe g1 is 12HP, parallel connects with outdoor unit. refer to Table.5-8 the connective pipe g1 diameter is 25.4/12.7;
The outdoor unit linked by Pipe g2 is 12HP, parallel connects with outdoor unit. refer to Table.5-8 the connective pipe g2 diameter is 25.4/12.7;
The outdoor unit linked by Pipe g3 is 22HP, parallel connects with outdoor unit. refer to Table.5-8 the connective pipe g3 diameter is 31.8/15.9.
- 2) The upstream of G1 is the two parallel connected outdoor units, refer to Table.5-8 select the three parallel connected outdoor unit, the pipe diameter is 38.1/19.1.
- 3) Parallel connect the three outdoor units, refer to Table.5-8 should select FQZHW-03N1D for outdoor unit connective pipes (M+N).

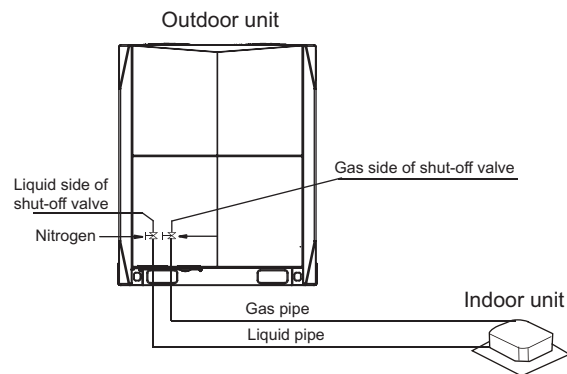

Fig.5-5

5.8 Remove dirt or water in the piping

- Make sure there is no any dirt or water before connecting the piping to the outdoor units.
- Wash the piping with high pressure nitrogen, never use refrigerant of the outdoor unit.

5.9 Gas tight test

- 1) Upon set up the indoor unit pipeline, please connect the Hi-pressure pipe with shut-off valve firstly.
- 2) Weld the pipe at the low pressure side to the meter connector.
Use the vacuum pump discharging air inside the liquid side shut-off valve and meter connector, until to the -1kgf/cm².
- 3) Close the vacuum pump, charge 40kgf/cm² nitrogen gas from the piston of shut-off valve and from the meter connector. Pressure inside should be maintained at there no less than 24 hrs.
- 4) Upon the airtightness test, do a good welding between float valve and pipe at the low pressure side.
- 5)



CAUTION

- Pressurized nitrogen (3.9MPa; 40kgf/cm²) is used for airtightness test.
- It is not allow to bring pressure on the float valve directly. (See Fig. 5-5)
- It is not allow to use oxygen, combustible gas or toxic gas to conduct the airtightness test.
- When welding, please use wet cloth insulating the two shut-off valves for protection.
- For avoid the equipment be damaged, the pressure maintainedtime should not last too long.

5.10 Vacuum with vacuum pump

- 1) Use the vacuum pump which vacuum level lower than -0.1MPa and the air discharge capacity above 4L/S.
- 2) The outdoor unit is not necessary to vacuum, don't open the outdoor unit gas and liquid pipe shut-off valves.
- 3) Make sure the vacuum pump could result as -0.1MPa or below after 2 hrs or above operation. If the pump operated 3 hrs or above could not achieve to -0.1MPa or below, please check whether water mix or gas leak inside of the pipe.

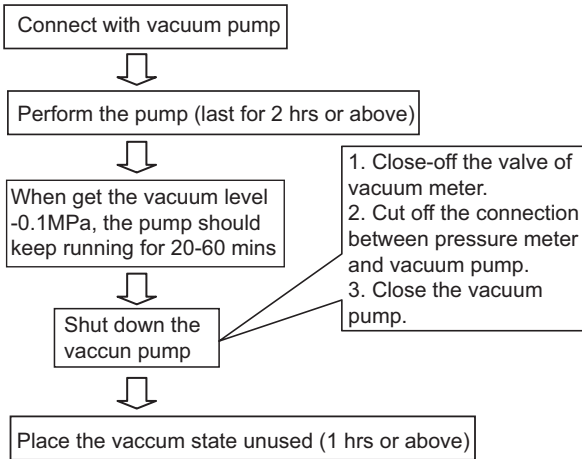
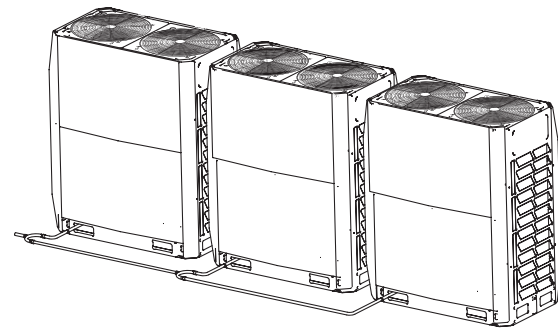
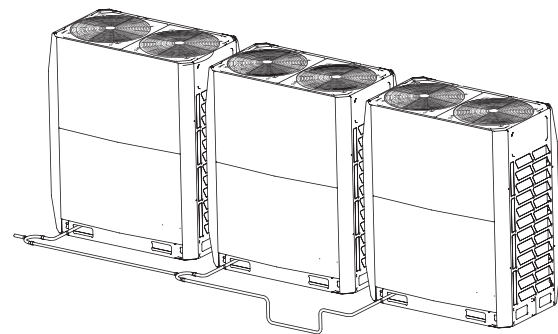

Fig.5-6



√ Correct way

Fig.5-7



× Wrong way

Fig.5-8



CAUTION

- Don't mix up the different refrigerants or abuse the tools and measurements which directly contact with refrigerants.
- Don't adopt refrigerant gas for air vacuuming.
- If vacuum level could not get to -0.1MPa, please check whether resulted by leakage and confirm the leakage site. If no leakage, please operate the vacuum pump again 1 or 2 hrs.

5.11 Refrigerant amount to be added

Calculate the added refrigerant according to the diameter and the length of the liquid side pipe of the outdoor/indoor unit connection. The refrigerant is R410A.

Table.5-10

Pipe size on liquid side	Refrigerant to be Added per meter
Φ6.4	0.022kg
Φ9.5	0.057kg
Φ12.7	0.110kg
Φ15.9	0.170kg
Φ19.1	0.260kg
Φ22.2	0.360kg
Φ25.4	0.520kg
Φ28.6	0.680kg

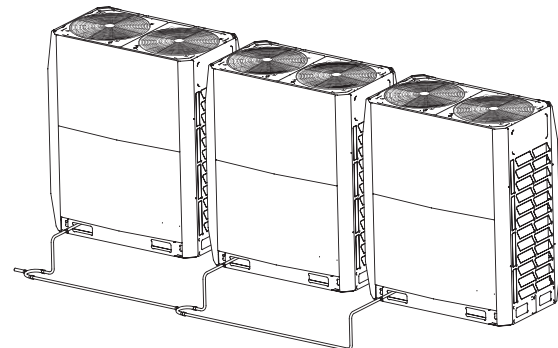

√ Correct way

Fig.5-9

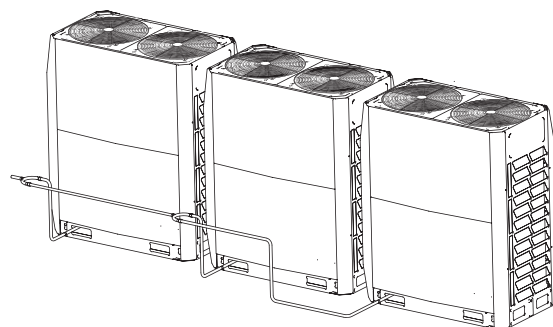

× Wrong way

Fig.5-10

5.12 The Installation key points of connective pipes between outdoor units

- 1) Connect the pipes between outdoor units, the pipes should place horizontally (Fig.5-7, Fig.5-8), it is not allow the concave at junction site (Refer to Fig.5-9).
- 2) All connective pipes between the outdoor units are not allowed to over than the height of every outlets of the pipes (Refer to Fig.5-10).

- 3) The branch joint must be installed horizontally, error angle of it should not large than 10°. Otherwise, malfunction will be caused.

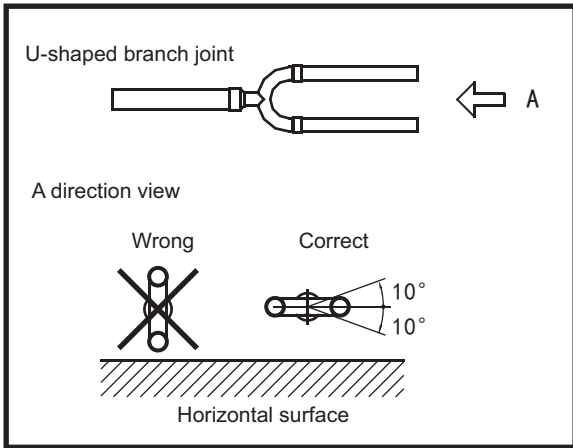

Fig.5-11

- 4) For avoid oil accumulate at the outdoor unit, please install the branch joints properly.

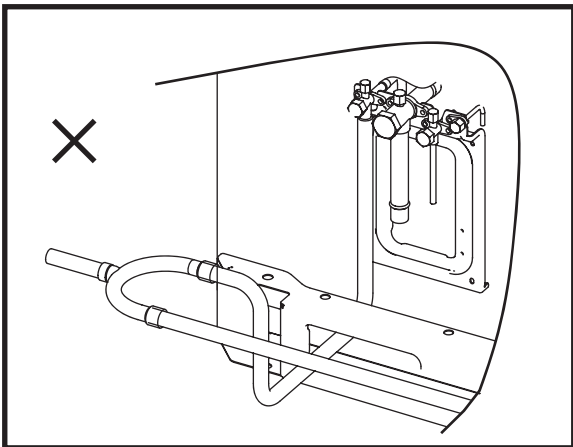

Fig.5-12

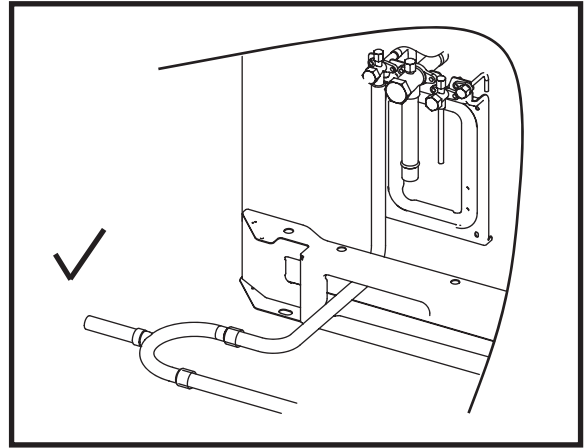

Fig.5-14

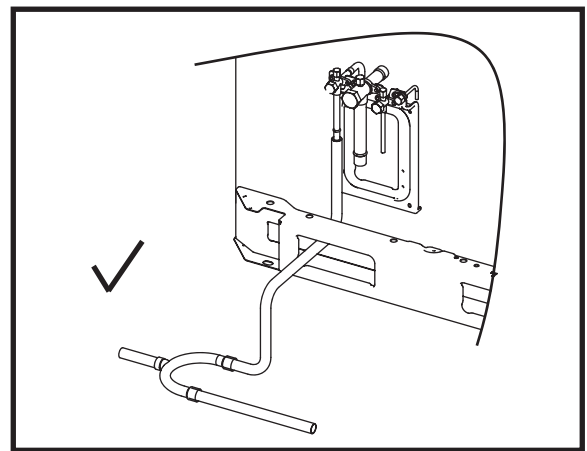

Fig.5-15

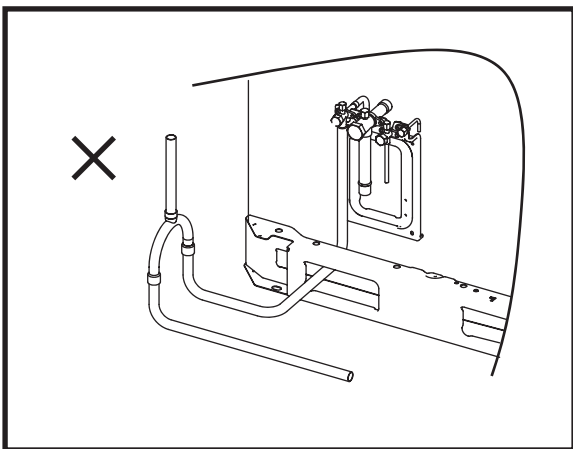

Fig.5-13

6. ELECTRIC WIRING

6.1 Sw2 query instructions

Use application of the SW2 spot check Table.6-1

No.	Display content (Normal display)	Note
1	Outdoor unit address	0, 1, 2, 3
2	Outdoor unit itself capacity	8, 10, 12, 14, 16, 18, 20, 22
3	Modular outdoor unit qty.	Available for main unit
4	Qty.setting of indoor units	Available for main unit
5	Total capacity of outdoor unit	Capacity requirement
6	Total requirement of indoor unit capacity	Available for main unit
7	Total requirement of main unit corrected capacity	Available for main unit
8	Operation mode	0,2,3,4 (Note 2)
9	This outdoor unit actual operation capacity	Capacity requirement
10	Speed of fan A	0, ... ,15 (Note 3)
11	Speed of fan B	0, ... ,15 (Note 3)
12	T2B/T2 average temp.	Actual value
13	T3 pipe temp.	Actual value
14	T4 ambient temp.	Actual value
15	Discharge Temp.of Inverter compressor A	Actual value
16	Discharge Temp.of Inverter compressor B	Actual value
17	Heat sink Temp.	Actual value
18	Discharge pressure corresponding to the saturation temperature	Display value +30
19	Current of inverter compressor A	Actual value
20	Current of inverter compressor B	Actual value
21	Opening angle of EXV A	Display value x 8
22	Opening angle of EXV B	Display value x 8
23	High pressure (BAR)	Actual value
24	Low pressure(Reserve)	
25	Qty. of Indoor units	That can communicate with indoor units
26	Qty. of the working Indoor units	Actual value
27	Priority mode	0,1, 2, 3, 4 (Note 5)
28	Night noise control mode	0,1, 2, 3 (Note 6)
29	Static pressure mode	0,1, 2, 3 (Note 7)
30	DC voltage A	Display value x 10
31	DC voltage B	Display value x 10
32	Reserve	
33	The last-time error or the protection code	If there is no protection or error, the panel will display 0.0.0.
34	Error clearance time	Actual value
35	----	Check end

Notes: The display contents as followings:

- 1) Normal display:When standby, the high position displays the address of the outdoor unit,and the low position displays the Qty.of indoor units that can communicate with outdoor unit .When it is operating, it will display the rotation frequency of the compressor.
- 2) Operation mode: 0-OFF; 2-Cooling; 3-Heating; 4-Constraint cooling.
- 3) Fan speed: 0-stop; 1~15: speed increase sequentially, 15 is the max. fan speed.
- 4) EXV opening angle: Pulse count=display value×8;
- 5) Priority mode: 0-heating priority mode ; 1-cooling priority mode; 2-Number 63 & the more operating mode first ; 3-respond the heating mode only ; 4-respond the cooling mode only.
- 6) Night noise control mode:0-Night noise control mode ; 1- silent mode ; 2-most silent mode;3-no priority.
- 7) Static pressure mode:0-Static pressure is 0 Mpa ; 1-Static pressure mode is low pressure ; 2-Static pressure mode is medium pressure ; 3-high static pressure mode is high pressure.

6.2 Terminal base function

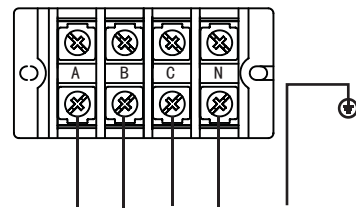

To 380-415V 3N~ 50Hz/60Hz

Fig.6-1

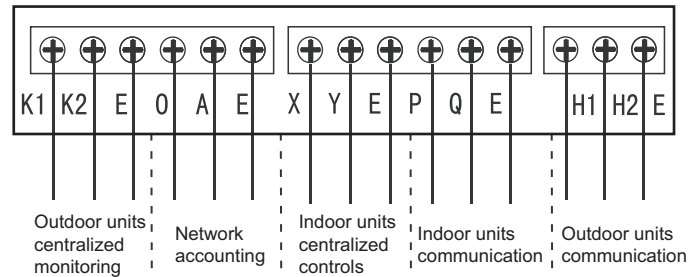

Fig.6-2

6.3 Electric wiring system and installation

Outdoor unit power wiring

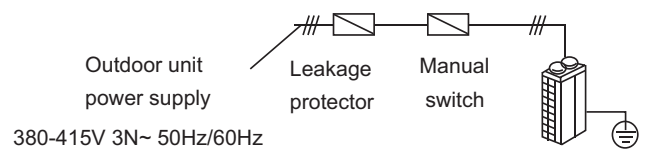

Fig.6-3

6.4 Electric parameter form of outdoor unit

Table.6-2

System	Outdoor Unit				Power Current			Compressor		OFM	
	Voltage	Hz	Min.	Max.	MCA	TOCA	MFA	MSC	RLA	KW	FLA
8HP	380~415	50/60	342	440	17.8	22.8	25	-	14.58	0.465	4.6
10HP	380~415	50/60	342	440	20.3	22.8	25	-	14.58	0.465	4.6
12HP	380~415	50/60	342	440	21.9	23.7	25	-	15.62	0.465	4.5
14HP	380~415	50/60	342	440	29	29.8	35	-	10.23+10.23	0.29+0.23	2.8+2.4
16HP	380~415	50/60	342	440	30.1	29.8	35	-	10.23+10.23	0.29+0.23	2.8+2.4
18HP	380~415	50/60	342	440	36.3	37.9	40	-	15.62+9.36	0.42+0.35	3.9+3.5
20HP	380~415	50/60	342	440	42.8	48.3	50	-	15.62+15.62	0.44+0.35	4.0+3.4
22HP	380~415	50/60	342	440	46.4	48.3	50	-	15.62+15.62	0.44+0.35	4.0+3.4

Notes:

1. The current value of combination unit is the total value of each basic model (refer to Table.6-2)

For example: 46HP=22HP+12HP+12HP

Power current: MCA=39.63+18.38+18.38=76.39

TOCA=44.9+23+23=90.9

MFA=50+25+25=100

Compressor: RLA=15.62+15.62+15.62+15.62=62.48

OFM: FLA=4.0+3.4+4.5+4.5=16.4

2. RLA is based on the following conditions, Indoor temp. 27°C DB/19°C WB, Outdoor temp. 35°C DB

3. TOCA means the total value of each OC set.

4. MSC means the Max. current during the starting of compressor.

5. Voltage range units are suitable for use on electrical systems where voltage supplied to unit terminals is not below or above listed range limits.

6. Maximum allowable voltage variation between phase is 2%

7. Selection wire size based on the larger value of MCA or TOCA

8. MFA is used to select the circuit breaker and the ground fault circuit interrupter (earth circuit breaker).

Remark:

MCA: Min. Current Amps. (A)

TOCA: Total Over-current Amps. (A)

MFA: Max. Fuse Amps. (A)

MSC: Max. Starting Amps. (A)

RLA: Rated Locked Amps. (A)

OFM: Outdoor Fan Motor.

FLA: Full Load Amps. (A)

KW: Rated Motor Output (KW)

6.5 Electric wiring system and installation

CAUTION

- Please select power supply for indoor unit and outdoor unit separately.
- The power supply should have specified branch circuit with leakage protector and manual switch.
- The power supply, leakage protector and manual of all the indoor units connecting to the same outdoor unit should be universal. (Please set all the indoor unit power supply of one system into the same circuit. It should turn on or shut down the unit at the same time, otherwise, the service life would affect seriously, even the unit may not turn on.)
- Please put the connective wiring system between indoor unit and outdoor unit with refrigerant piping system together.
- It is suggested to use 3-core shielded wire as signal wire between indoor and outdoor units, multi-core wire is unavailable.
- Please comply with relevant National Electric Standard.
- Power wiring should be done by professional electrician.

6.5.1 Outdoor unit power wiring

- Separate Power Supply (without power facility) (See Table.6-3)

Table.6-3

Item Model	Power supply	Min. Power wire diameter (mm ²) Wiring of metal and synthetic resin		Manual switch (A)		Leakage protector
		Size (Continuous length of pipe m)	Grounding wire	Capacity	Fuse	
8~12HP	380-415V 3N~50Hz /60Hz	4×10 mm ² (<20 m)	1×10 mm ²	32	25	100mA 0.1sec or less
		4×16 mm ² (<50 m)				
14HP		4×10 mm ² (<20 m)	1×10 mm ²	40	35	
		4×16 mm ² (<50 m)				
16HP		4×10 mm ² (<20 m)	1×10 mm ²	40	35	
	4×16 mm ² (<50 m)					
18HP	4×16 mm ² (<20 m)	1×16mm ²	50	40		
	4×25 mm ² (<50 m)					
20~22HP	4×16 mm ² (<20 m)	1×16mm ²	63	50		
	4×25 mm ² (<50 m)					

NOTE

- Select power cord for these models separately according to relevant standard.
- The wiring diameter and the length in the table indicate the condition that the voltage dropping range is within 2%. If the length exceeds the above figure, please select the wire diameter according to relevant standard.

- With power facilities

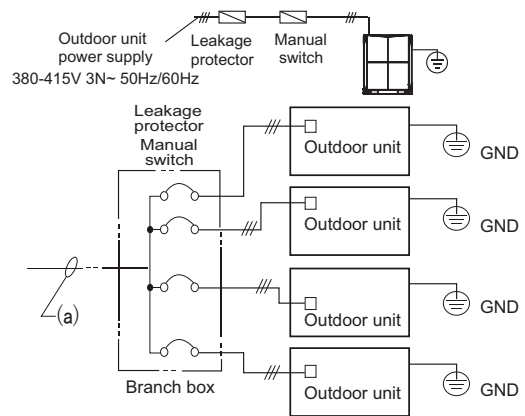

Fig.6-5

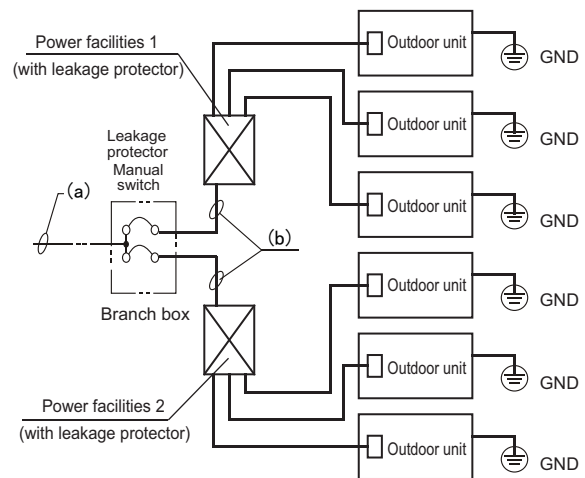

Fig.6-6

- Select the wire diameter
Power wiring refer to the main wire (a) connecting to branch box and the wiring (b) between branch box and power facilities. Please select the wire diameter according to the following requirement.
- Diameter of main wire (a)
Depends on the total horsepower of outdoor unit and following table.
E.g In system:(8Hp×1unit+8Hp×1unit+10Hp×1unit)
Total Hp=26Hp→(Table.6-3)→size of wire=35mm²(within 50m)
- Wiring(b):between branch box and power equipment.
Depends on the number of combined outdoor unit. If fewer than 5, the diameter is the same as that of main wire (a); if more than 6, there will be 2 electric control boxes, and the diameter of wiring depends on the total horsepower of outdoor units connecting to each electric control box and following table.

- Select wire diameter (≥) (table.6-4) (unit :mm²)

Table.6-4

Total HP	<20m	<50m
8	10	16
10	10	16
12	10	16
14	16	25
16	16	25
18	16	25
20	16	25
22	16	25
24	25	35
26	25	35
28	25	35
30	35	50
32	35	50
34	35	50
36	35	50
38	35	50
40	35	50
42	50	70
44	50	70
46	50	70
48	50	70
50	70	95
52	70	95
54	70	95
56	90	110
58	90	110
60	90	110
62	90	110
64	90	110
66	90	110
68	90	110
70	90	110
72	90	110
74	90	110
76	90	110
78	90	110
80	90	110
82	90	110
84	90	110
86	90	110
88	90	110

- Select the capacity of manual switch and fuse of the branch box.
- See following table when without power facilities, depends on the outdoor unit it connecting to.
- See table. 6-4 below when there is power facility, depends on the total horsepower.

Table.6-5 Total horsepower, capacity of manual switch and fuse

Total (HP)	Manual switch (A)	Fuse(A)	Total (HP)	Manual switch (A)	Fuse(A)
8~12	32	25	30~34	100	80
14	40	35	36~40	125	100
16	40	35	42~44	125	100
18	50	40	46~50	150	125
20~22	63	50	52~60	200	150
24~28	80	70	62~88	250	200

- Indoor power supply

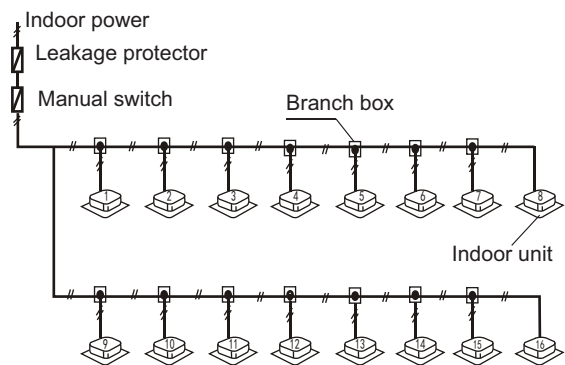

Fig.6-7



CAUTION

- Set refrigerant piping system, signal wires between indoor-indoor unit, and that between outdoor-outdoor unit into one system.
- Power must unified supply to all indoor units in the same system.
- Please do not put the signal wire and power wire in the same wire tube; keep distance between the two tubes. (Current capacity of power supply: less than 10A--300mm, less than 50A--500mm.)
- Make sure to set address of outdoor unit in case of parallel multi-outdoor units.

6.5.2 Cable clips of main power wire instructions

The attached cable clip includes 2 parts: the base part and the upper cover part. The base has been installed in the electric control box, locating under the terminals. The upper cover is put together with the other accessories as an attachment. Both the front and back side of the cable clip can be used to groove wire. Please choose the appropriate way to groove the wire according to different sizes of power wire. Upper cover of the cable clip must be fixed by three M4*30mm screws. When the cross sectional area of the power wire is less than 10mm², please groove the power wires as a whole. When stripping the outermost insulating layer, ensure the sum of stripped length and terminal length are less than 70mm. Shown as figure 6-8:

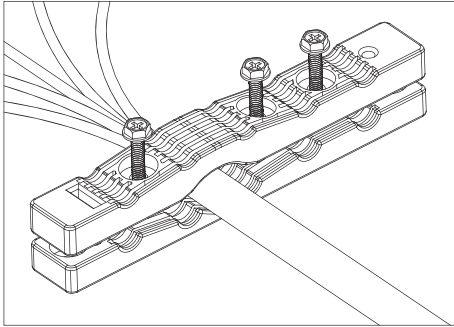

Fig.6-8

When the cross sectional area of the power wire is more than 10mm², please groove the power wires separately. When stripping the outermost, ensure the sum of stripped length and terminal length is between 100mm and 200mm. Shown as figure 6-9:

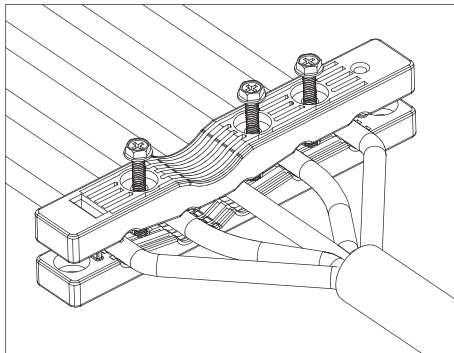

Fig.6-9



CAUTION

- Firstly, connect the power wires and the terminals, and then groove the wires, otherwise it's hard to install.
- When installing the main power wire, strip of appropriate length of the insulation layer according to the grooving way and position of the cable clip.
- When install the three fixed screws, twisting length should ensure the displacement is less than 2 mm when applying 100 N force onto the wires. If twisting to the end wilfully, it may lead to power wire protective cover damage.

6.6 Control system and Installation

- The control line should be shielded wire. Using other wiring shall create signal interference, thus leading to error operation.
- The shielded nets at the two sides of shielded wires are either grounded to the earth, or connected with each other and jointed to the sheet metal along to the earth.
- Control wire could not be bound together with refrigerant pipeline and power wire. When power wire and control wire is distributed in parallel form, keep gap between them above 300mm so as to preventing signal interference.
- Control wire could not form closed loop.
- Control wire has polarity, so be careful when connecting.



NOTE

The shield net should be grounded at the wiring terminal of outdoor unit. The inlet and outlet wire net of indoor communication wire should be connected directly and could not be grounded, and form open circuit at the shield net of final indoor unit.

6.7 Signal wire of indoor/outdoor units

- Signal wire of indoor/outdoor unit adopts 3-core shielded wire (≥0.75mm²) which has polarity, please connect it correctly.

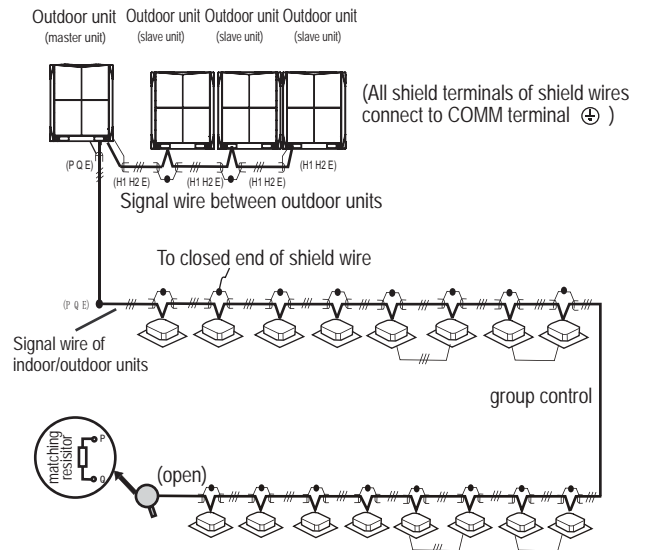

The indoor unit at the terminal of communication system should parallel connect a impedance between port P and port Q.

Fig.6-10

6.8 Example for power wire connection

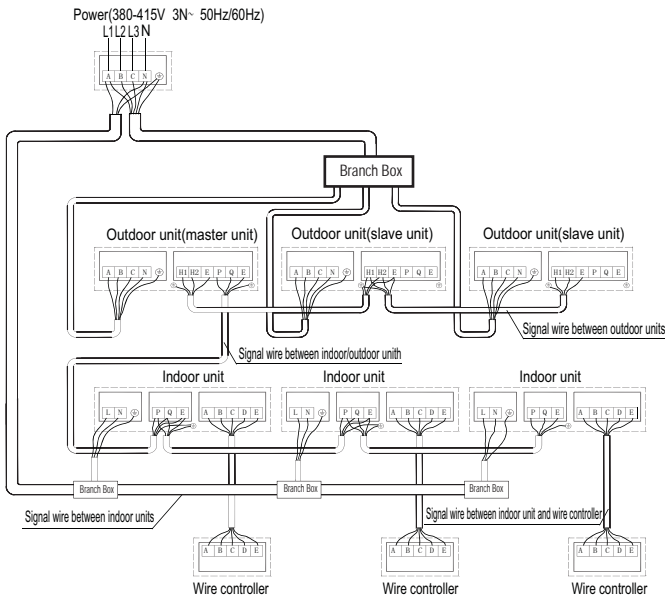

Fig.6-11

- Turn on air pipe stop valve, liquid pipe stop valve, oil balance valve and air balance valve totally. If the above valves do not be turned on totally, the unit should be damaged.
- Check whether the power phase sequence of outdoor unit is correct.
- All dial switch to indoor and outdoor unit have been set according to the Technical Requirement of Product.

7.3 Fill the name of connected system

To clearly identify the connected systems between two or more indoor units and outdoor unit, select names for every system and record them on the nameplate on the outdoor electric control box cover.

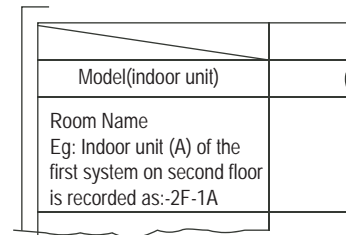

Fig.7-1

7. TRIAL RUN

7.1 Inspection and confirmation before commissioning

- Check and confirm that refrigeration pipe line and communication wire with indoor and outdoor unit have been connected to the same refrigeration system. Otherwise, operation troubles shall happen.
- Power voltage is within $\pm 10\%$ of rated voltage.
- Check and confirm that the power wire and control wire are correctly connected.
- Check whether wire controller is properly connected.
- Before powering on, confirm there is no short circuit to each line.
- Check whether all units have passed nitrogen pressure-keeping test for 24 hours with R410A: 40kg/cm².
- Confirm whether the system to debugging has been carried out vacuum drying and packed with refrigeration as required.

7.2 Preparation before debugging

- Calculating the additional refrigerant quantity for each set of unit according to the actual length of liquid pipe.
- Keep required refrigerant ready.
- Keep system plan, system piping diagram and control wiring diagram ready.
- Record the setting address code on the system plan.
- Turn on power switches outdoor unit in advance, and keep connected for above 24 hours so that heater heating up refrigerant oil in compressor.

7.4 Caution on refrigerant leakage

- This air conditioner adopts R410A as refrigerant, which is safe and noncombustible.
- The room for air conditioner should be big enough that refrigerant leakage can not reach the critical thickness. Besides this, you can take some action on time.
- Critical thickness----the max thickness of Freon without any harm to person. R410A critical thickness: 0.42 [kg/m³]

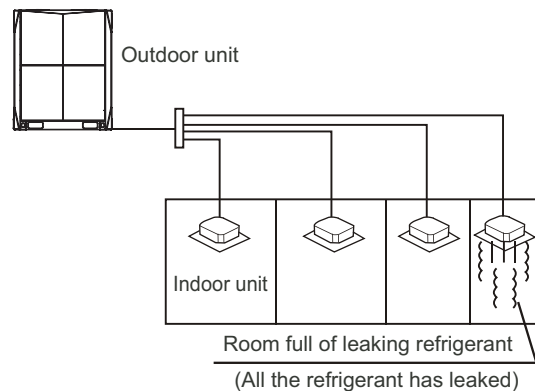

Fig.7-2

- Calculate the critical thickness through following steps, and take necessary actions.
 - Calculate the sum of the charge volume (A[kg])
Total refrigerant volume=refrigerant volume when delivered(nameplate)+superaddition
 - Calculate the indoor cubage (B[m³]) (as the minimum cubage)

- Calculate the refrigerant thickness.

$$\frac{A \text{ [kg]}}{B \text{ [m}^3\text{]}} \leq \text{Critical thickness: } 0.42 \text{ [kg/m}^3\text{]}$$

- Countermeasure against overhigh thickness
 - Install mechanical ventilator to reduce the refrigerant thickness under critical level. (ventilate regularly)
 - Install leakage detector alarming device related to mechanical ventilator.

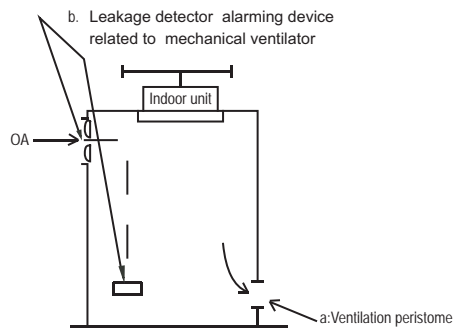

Fig.7-3

OWNER'S MANUAL

CONTENTS

PAGE

IMPORTANT SAFETY INFORMATION.....	28
PARTS NAMES.....	29
OPERATION AND PERFORMANCE.....	29
TROUBLES AND CAUSES.....	30
MALFUNCTION.....	32
CONSTRAINT COOLING AND QUERY.....	33
DIAL SWITCH SETTING.....	34
AFTER-SALES SERVICE.....	35

1. IMPORTANT SAFETY INFORMATION

To prevent injury to the user or other people and property damage, the following instructions must be followed. Incorrect operation due to ignoring of instructions may cause harm or damage.

The safety precautions listed here are divided into two categories. In either case, important safety information is listed which must be read carefully.



WARNING

Failure to observe a warning may result in death. The appliance shall be installed in accordance with national wiring regulations.



CAUTION

Failure to observe a caution may result in injury or damage to the equipment.



WARNING

- **Ask your dealer for installation of the air conditioner.**
Incomplete installation performed by yourself may result in a water leakage, electric shock, and fire.
- **Ask your dealer for improvement, repair, and maintenance.**
Incomplete improvement, repair, and maintenance may result in a water leakage, electric shock, and fire.
- **In order to avoid electric shock, fire or injury, or if you detect any abnormality such as smell of fire, turn off the power supply and call your dealer for instructions.**
- **Never replace a fuse with that of wrong rated current or other wires when a fuse blows out.**
Use of wire or copper wire may cause the unit to break down or cause a fire.
- **Do not insert fingers, rods or other objects into the air inlet or outlet.**
When the fan is rotating at high speed, it will cause injury.
- **Never use a flammable spray such as hair spray, lacquers paint near the unit.**
It may cause a fire.
- **Never touch the air outlet or the horizontal blades while the swing flap is in operation.**
Fingers may become caught or the unit may break down.
- **The appliance shall be installed in accordance with national wiring regulations**

- **Never inspect or service the unit by yourself.**
Ask a qualified service person to perform this work.
- **Do not dispose this product as unsorted municipal waste. Collection of such waste separately for special treatment is necessary.**
- **Do not dispose of electrical appliances as unsorted municipal waste, use separate collection facilities.**
Contact you local government for information regarding the connection systems available.
- **If electrical appliances are disposed of in landfills or dumps, hazardous substances can leak into the groundwater and get into the food chain, damaging your health and well-being.**
- **Keep far away from high-frequency equipment.**
- **Keep away from the following places:**
a place where it is full of ail gas; a place where salty air surrounding or near the coast (except for the models with corrosion-resistant function); a place where is caustic gas(the sulfide in hot spring). Location in the following places may cause malfunction or shorten the life span of the machine.
- **In the case of extremely strong wind, please prevent the air from flowing backwards into the outdoor unit.**
- **Snow canopy is necessary in snowfall places on the outdoor unit. Please consult the local dealer for details.**
- **In the frequent thunderstruck place, lightningproof actions should be taken.**
- **To prevent refrigerant leak, contact your dealer.**
When the system is installed and runs in a small room, it is required to keep the concentration of the refrigerant, if by any chance coming out, below the limit. Otherwise, oxygen in the room may be affected, resulting in a serious accident.
- **The refrigerant in the air conditioner is safe and normally does not leak.**
If the refrigerant leaks in the room, contact with a fire of a burner, a heater or a cooker may result in a harmful gas.
- **Turn off any combustible heating devices, ventilate the room, and contact the dealer where you purchased the unit.**
Do not use the air conditioner until a service person confirms that the portion where the refrigerant leaks is repaired.



CAUTION

- **The cooling&heating indoor unit is applicable for the cooling&heating and the cooling only outdoor unit;the heating capacity of the indoor unit will be effective only when the indoor unit connect to the cooling&heating outdoor unit.**
- **Do not use the air conditioner for other purposes.**
In order to avoid any quality deterioration, do not use the unit for cooling precision instruments, food, plants, animals or works of art.

- **Before cleaning, be sure to stop the operation, turn the breaker off or pull out the supply cord.**
Otherwise, an electric shock and injury may result.
- **In order to avoid electric shock or fire, make sure that an earth leak detector is installed.**
- **Be sure the air conditioner is grounded.**
In order to avoid electric shock, make sure that the unit is grounded and that the earth wire is not connected to gas or water pipe, lightning conductor or telephone earth wire.
- **In order to avoid injury, do not remove the fan guard of the outdoor unit.**
- **Do not operate the air conditioner with a wet hand.**
An electric shock may happen.
- **Do not touch the heat exchanger fins.**
These fins are sharp and could result in cutting injuries.
- **After a long use, check the unit stand and fitting for damage.**
If damaged, the unit may fall and result in injury.
- **To avoid oxygen deficiency, ventilate the room sufficiently if equipment with burner is used together with the air conditioner.**
- **Arrange the drain hose to ensure smooth drainage.**
Incomplete drainage may cause wetting of the building, furniture etc.
- **Never expose little children, plants or animals directly to the air flow.**
Adverse influence to little children, animals and plants may result.
- **Notice to avoid places where operation noise may easily be spread away or be enhanced.**
- **Noise can be amplified by anything blocking the air outlet of outdoor unit.**
- **Choose a proper place that the noise and hot or cold wind blown out of the outdoor unit will not bring inconvenience to your neighbors and not affect the growth or animal or plant.**
- **Do not allow a child to mount on the outdoor unit or avoid placing any object on it.**
Falling or tumbling may result in injury.
- **Do not operate the air conditioner when using a room fumigation - type insecticide.**
Failure to observe could cause the chemicals to become deposited in the unit, which could endanger the health of those who are hypersensitive to chemicals.
- **Do not place appliances which produce open fire in places exposed to the air flow from the unit or under the indoor unit.**
It may cause incomplete combustion or deformation of the unit due to the heat.
- **Do not install the air conditioner at any place where flammable gas may leak out.**
If the gas leaks out and stays around the air conditioner, a fire may break out.
- **The appliance is not intended for use by young children or infirm persons without supervision.**
- **Young children should be supervised to ensure that they do not play with the appliance.**

2. PARTS NAMES

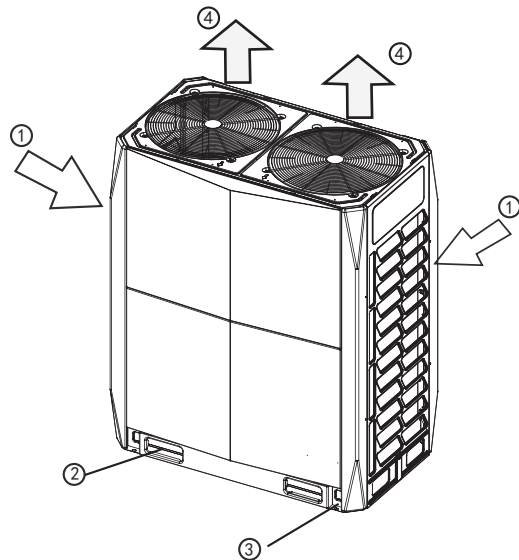

Fig.2-1

The figure shown above is for reference only, the specific panel shall prevail.

①	Air inlet (Both in Left and right sides, as well as in rear side.)
②	Refrigerant pipe connective opening and wires outlet
③	Fixed foot
④	Air outlet (heat air to be blows out in the cooling operation, vice versa while the heating.)



NOTE

- All the pictures in this manual are for explanation purpose only, There may be slightly different from the air conditioner you purchased (depend on model). The actual shape shall prevail.
- To avoid danger, never put sticks or other objects into it.
- Please preheat the air conditioner for at least 12 hours before operation. Do not switchoff the power if you need to stop the unit for 24h or shorter time. (This is to heat the crank case heater to avoid the compulsive start of compressor.)
- Make sure the air inlet and outlet are not blocked, or it may degrade the performance of air conditioner or start up protector which will stop the unit from running.

3. OPERATION AND PERFORMANCE

■ Cooling and heating operation of inverter central DC

- The indoor unit of this air conditioner can be controlled solely, and the indoor unit in the same system can not run cooling and heating at the same time.
- When the Cooling and Heating operation confront with each other, please determine the problem according to the settings of outdoor unit Mode dial code S5.
 1. When set as the Heating Priority Mode, the indoor unit on Cooling Mode would stop and there will be Standby or No Priority displayed on the control panel. Those indoor units which are running on Heating Mode will run continuously.
 2. When the Cooling Priority Mode has been set, the indoor unit on Heating Mode would stop and there will be Standby or No Priority displayed on the control panel. Those indoor units which are running on Cooling Mode will run continuously;

3. When the Priority Mode has been set, the first indoor unit will work in Heating Mode that is Heating Priority, please refer to the ITEM 1 for the control logic. If the first indoor unit is work in Cooling Mode, that is the Cooling Priority Mode, please refer to the ITEM 2 for the control logic;

4. In terms of the settings only respond the Heating Mode, the indoor unit will run in Heating Mode normally, if unit be run in the Cooling Mode or air Supply Mode, the indoor unit will display Mode Conflicting;

5. In terms of the settings only respond the Cooling Mode, the indoor unit will run in Cooling Mode or air supply mode normally, if unit be run in the Heating Mode, the indoor unit will display Mode Conflicting.

■ Features of heating operation

- Warm air will not be blown out immediately at the beginning of the heating operation, after 3~5minutes (depends on the indoor and outdoor temperature), until the indoor heat exchanger become hot, then blows out warm air.
- During operation, the fan motor in the outdoor unit may stop running under high temperature.
- During Fan operation, if other indoor Units are running on heating mode, the fan may stop in order to prevent sending heat wind.

■ Defrost in the heating operation

- During heating operation, outdoor unit sometimes will frost. To increase efficiency, the unit will start defrosting automatcally (about 2~10 minutes), and then water will be drained out from outdoor unit.
- During defrosting, both the fan motors in the outdoor unit and indoor unit will stop running.

■ Operation conditions

For proper performance, run the air conditioner under the following temperature conditions:

Table.3-1

Temperature Mode	Outdoor temperature	Indoor temperature	Room relative humidity
Cooling mode	-5°C ~ 48°C	17°C ~ 32°C	below 80%
Heating mode	-20°C ~ 24°C	≤27°C	



NOTE

Protective device may start if running the unit outside the above condition, which will prevent the unit from operation.

■ Protection Device

This protection device will stop the unit automatically in case the air conditioner is on forced running mode. When protection device is activated, running indicator light is lightened and query light flashes. Protection device may start under the following circumstances:

■ Cooling operation:

- The air inlet or air outlet of outdoor unit is blocked.
- Strong wind is continuously blowing to the air outlet of the outdoor unit.

■ Heating operation:

- Too much dust and rubbish adhere to the dust filter in the indoor unit

■ Power cut

- If power is cut during operation, stop all the operation immediately.
- Power comes again. The operation indicator on the wire controller flashes.
- Push the ON/OFF button again if you want to restart the unit.

■ Mishandling in operation

In case of mishandling caused by lighting or mobile wireless, please switch off the manual power off the manual power. Push ON/OFF again when restarting.

■ Heating capacity

- The heating process is :absorb heat from outdoor, while expel heat to indoor by hot pump. Once the outdoor temperature drop down, heating capacity is degraded correspondingly.
- It is command to equip with other warming facility, when outdoor temperature is low.
- It is better to equip with additional purchase indoor auxiliary heating device in area where is in particularly low outdoor temperature. (See Indoor Unit Operation Manual for detail information)



NOTE

Please switch off the power when protection device starts. Do not restart until the problems are solved.

4. TROUBLES AND CAUSES



CAUTION

- In case the following malfunctions, please switch off the power and contact the local dealer.Incorrect ON/OFF operation
- Fuse or leakage protector is frequently broken.
- Foreign matter or water falls in the unit.

Please read the following illustration (before apply for servicing)

Table.4-1

	Troubles	Causes
Not malfunction	Outdoor unit <ul style="list-style-type: none"> • White mist or water • The sound of "hiss" 	<ul style="list-style-type: none"> • FAN function stop automatically to defrost. It is the start and stop sound of the solenoid valve • At the beginning and the end of the running process, sounds like water flow in valve occurs, which will be amplified in 3~15 minutes, this is caused by dehumidifying process of refrigerant current. • Slight hiss is caused by heat exchanger as temperature changes. • Pieces of the wall, carpet, furniture, cloth, cigarette, cosmetics are adhere to the unit. • Switch on the power after the power cut. • Other equipment preheating process stops cooling operation. • The operator sets an opposite mode against the fixed cooling and heating mode. • FAN mode stops to avoid cold air blown out. • The master unit with slave units for different purposes, when abnormal accident happen, the director will illustrate.
	Indoor unit <ul style="list-style-type: none"> • Bad odor • Operation lamp flashes • No priority of Standby on panel is lightened 	
Check it again	<ul style="list-style-type: none"> • Start or stop operation automatically 	<ul style="list-style-type: none"> • Wrong operation on timer.
	<ul style="list-style-type: none"> • No operation 	<ul style="list-style-type: none"> • Whether the power is cut. • Whether manual power switch is turned on. • Whether the fuse is melted. • Whether the protection device works. (operation lamp is lightened) • Whether it is the time set.
	<ul style="list-style-type: none"> • Insufficient cooling • Insufficient heating 	<ul style="list-style-type: none"> • Whether the inlet and outlet of outdoor unit is blocked. • Whether the door and window are open. • Whether the air filter is blocked by dust. • Whether the air deflector is in the right place • Whether fan speed is slight or whether it is in FAN mode. • Whether the temperature is set properly. • Whether setting COOL and HEAT simultaneously. (Indicator light Standby or No Priority on panel is lightened)

5. MALFUNCTION

Malfunction display of outdoor unit's DSP1

Table.5-1

No.	Error code	Error or protection type	Note
1	E0	Outdoor unit communication error	Only display in slave unit
2	E1	Phase protection	
3	E2	Communication error between indoor and outdoor unit	20 minutes after first power on or indoor and outdoor communication break off over 2 minutes after first power on 20 minutes
4	E3	Reserved	
5	E4	Outdoor temp. sensor error	
6	E5	Voltage protection	
7	E6	Reserved	
8	E7	Discharge temp.sensor error	
9	E8	Outdoor unit address error	
10	xE9	Mismatch of drive model	X represents for a system, 1 is A system, 2 is B system
11	xH0	Communication error between IR341 and main chip	
12	H1	Communication error between 0537 and main chip	
13	H2	Qty.of outdoor unit decreases error	Only main unit will display
14	H3	Qty.of outdoor unit increases error	Only main unit will display
15	xH4	Unrecoverable module protection outage (P6)	X represents for a system, 1 is A system, 2 is B system, Not recoverable until re-power on
16	H5	3 times of P2 protection in 60 minutes	Not recoverable until re-power on
17	H6	3 times of P4 protection in 100 minutes	Not recoverable until re-power on
18	H7	Qty.of indoor units decreases error	Indoor unit lost for over 3 minutes; not recoverable, until the unit qty. recover
19	H8	High pressure sensor error	Air discharging pressure Pcs<0.3MPa
20	H9	3 times of P9 protection in 60 minutes	Not recoverable until re-power on
21	Hc	Reserved	
22	F0	3 times of PP protection in 150 minutes	Not recoverable until re-power on
23	C7	3 times of PL protection in 100 minutes	Not recoverable until re-power on
24	yHd	Slave unit error(y=1,2,3. e.g, 1Hd stands for slave unit1 error)	Y represents for a unit which is not No. 0
25	P0	Inverter compressor top Temp.protection	
26	P1	High pressure protection	
27	P2	Low pressure protection	After 3 times P2 protection in 60 minutes will report H5
28	xP3	Compressor current protection	X represents for a system, 1 is A system, 2 is B system
29	P4	Discharge Temp.Protection	After 3 times P6 protection in 100 minutes will report H6
30	P5	High condenser Temp.protection	
31	xP6	Inverter module protection	X represents for a system, 1 is A system, 2 is B system, after 3 times P6 protection in 60 minutes will report H4
32	P9	DC fan protection	After 3 times P9 protection in 60 minutes will report H9
33	PL	Temperature protection of inverter module	After 3 times PL protection in 100 minutes will report C7
34	pp	Protection of insufficient in degree of superheat of compressor discharging	After 3 times PP protection in 150 minutes will report F0
35	xL0	DC compressor module error	X represents for a system, 1 is A system, 2 is B system
36	xL1	DC bus low pressure protection	X represents for a system, 1 is A system, 2 is B system
37	xL2	DC bus high pressure protection	X represents for a system, 1 is A system, 2 is B system
38	xL3	Reserved	X represents for a system, 1 is A system, 2 is B system
39	xL4	MCE error/synchronization/closed loop	X represents for a system, 1 is A system, 2 is B system
40	xL5	Zero speed protection	X represents for a system, 1 is A system, 2 is B system
41	xL6	Reserved	X represents for a system, 1 is A system, 2 is B system
42	xL7	Phase error protection	X represents for a system, 1 is A system, 2 is B system
43	xL8	Protection of the speed change between a moment before and after is > 15Hz	X represents for a system, 1 is A system, 2 is B system
44	xL9	Protection of the speed change between the setting speed and the actual speed > 15Hz	X represents for a system, 1 is A system, 2 is B system

If the problem still existing, please contact the sales distributor or the service center, tell us your model No. and the detail of the error.

6. CONSTRAINT COOLING AND QUERY

■ Constant Cooling

Once pressing the constant cooling button (see the chart on the right), all the indoor unit will be on forced cooling mode and the wind speed is HIGH.

■ Use application of the SW2 spot check

Table.6-1

No.	Display content (Normal display)	Note
1	Outdoor unit address	0, 1, 2, 3
2	Outdoor unit itself capacity	8, 10, 12, 14, 16, 18, 20, 22
3	Modular outdoor unit qty.	Available for main unit
4	Qty.setting of indoor units	Available for main unit
5	Total capacity of outdoor unit	Capacity requirement
6	Total requirement of indoor unit capacity	Available for main unit
7	Total requirement of main unit corrected capacity	Available for main unit
8	Operation mode	0,2,3,4 (Note 2)
9	This outdoor unit actual operation capacity	Capacity requirement
10	Speed of fan A	0, ... ,15 (Note 3)
11	Speed of fan B	0, ... ,15 (Note 3)
12	T2B/T2 average temp.	Actual value
13	T3 pipe temp.	Actual value
14	T4 ambient temp.	Actual value
15	Discharge Temp.of Inverter compressor A	Actual value
16	Discharge Temp.of Inverter compressor B	Actual value
17	Heat sink Temp.	Actual value
18	Discharge pressure corresponding to the saturation temperature	Display value +30
19	Current of inverter compressor A	Actual value
20	Current of inverter compressor B	Actual value
21	Opening angle of EXV A	Display value x 8
22	Opening angle of EXV B	Display value x 8
23	High pressure (BAR)	Actual value
24	Low pressure(Reserve)	
25	Qty. of Indoor units	That can communicate with indoor units
26	Qty. of the working Indoor units	Actual value
27	Priority mode	0,1, 2, 3, 4 (Note 5)
28	Night noise control mode	0,1, 2, 3 (Note 6)
29	Static pressure mode	0,1, 2, 3 (Note 7)
30	DC voltage A	Display value x 10
31	DC voltage B	Display value x 10
32	Reserve	
33	The last-time error or the protection code	If there is no protection or error, the panel will display 0.0.0.
34	Error clearance time	Actual value
35	----	Check end

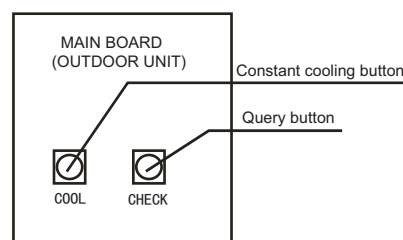

Fig.6-1

The display contents as followings:

(1) Normal display: When standby, the high position displays the adress of the outdoor unit, and the low position displays the Qty.of indoor units that can communicate with outdoor unit. When it is operating, it will display the rotation frequency of the compressor.

(2) Operation mode: 0-OFF; 2-Cooling; 3-Heating; 4-Forced cooling.

(3) Fan speed: 0-stop; 1~15: speed increase sequentially, 15 is the max. fan speed.

(4) EXV opening angle: Pulse count=display value×8;

(5) Priority mode: 0-heating priority mode ; 1-cooling priority mode; 2-Number 63 & the more operating mode first; 3-respond the heating mode only ; 4-respond the cooling mode only.

(6) Night noise control mode: 0-Night noise control mode; 1- silent mode; 2-most silent mode; 3-no priority .

(7) Static pressure mode: 0-Static pressure is 0-20Pa; 1-Static pressure mode is low pressure; 2-Static pressure mode is medium pressure; 3-static pressure mode is high pressure (20-40Pa).

7. DIAL SWITCH SETTING

S1: Starting time setting

	Starting time is 10 minutes
	Starting time is 12 minutes (default)

S2: Night silent time setting

	Night silent time is 6h/10h (default)
	Night silent time is 6h/12h
	Night silent time is 8h/10h
	Night silent time is 8h/12h

S3: Silent mode selection

	Night silent mode (default)
	Silent mode
	Super silent mode.
	None silent mode.

S4: Static pressure mode selection

	None static pressure(default) (0-20Pa)
	Low static pressure mode (reserved, can be customized)
	Medium static pressure mode (reserved, can be customized)
	High static pressure mode (20-40Pa)

ENC3+S12: Indoor unit quantity setting

		The quantity of indoor unit is 0-15 0~9 on ENC3 refer to 0~9 indoor units; A~F on ENC3 refer to 10~15 indoor units.
		The quantity of indoor unit is 16-31 0~9 on ENC3 refer to 16~25 indoor units; A~F on ENC3 refer to 26~31 indoor units.
		The quantity of indoor unit is 32-47 0~9 on ENC3 refer to 32~41 indoor units; A~F on ENC3 refer to 42~47 indoor units.
		The quantity of indoor unit is 48-63 0~9 on ENC3 refer to 48~57 indoor units; A~F on ENC3 refer to 58~63 indoor units.

Note:

ENC3 + S12 is only necessary to set if the S7 is configured as " Need to set the number of indoor units "
If the number of indoor units is configured , if the outdoor unit sometime not detect one of the indoor units , the outdoor will show H7 code and lock avoiding possible serious problem.

S5: Priority mode selection

	Heating priority mode (default)
	Cooling priority mode
	VIP (address no. 63) priority mode or voting priority mode
	Heating only priority mode
	Cooling only priority mode

S6: Auto addressing mode selection

	Auto addressing
	None auto addressing (default)
	Clean the indoor unit address

S7: Set the indoor units' numbers selection

	No need to set the numbers of indoor units (default)
	Need to set the numbers of indoor units

S8: Reserved

--	--

S10: Reserved

--	--

ENC1: Outdoor unit address setting

ENC1 	Only 0, 1, 2, 3 are available. 0 is for master unit; 1, 2, 3 are for slave units
---	---

ENC2: Outdoor unit capacity setting

ENC2 	Only 0, 1, 2, 3, 4, 5, 6, 7 are available. 0: 8HP; 1: 10HP; 2: 12HP; 3: 14HP; 4: 16HP; 5: 18HP; 6: 20HP; 7: 22HP.
---	--

ENC4: Network address setting

ENC4 	Only 0, 1, 2, 3, 4, 5, 6, 7 are available.
---	--

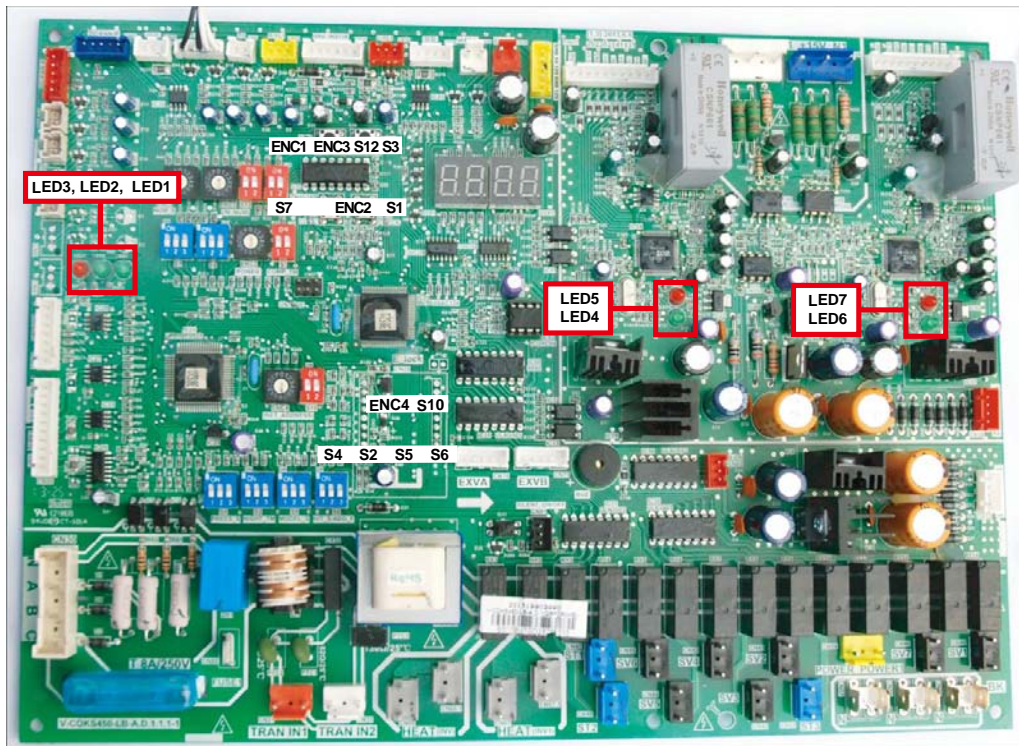
7.1 LED on main control board instructions

LED1: Power supply indicator lamp. The lamp will be on if the power supply is normal.

LED2: Running indicator lamp. The lamp will be on if the system running is normal.

LED3: Malfunction indicator lamp of network centralized control chip. The lamp will flash if three-phase sequence protection or communication errors (communication between indoor units and outdoor units, communication among indoor units, communication among chips).

LED4: Running indicator lamp of inverter module. The lamp will be on if the compressor is running.

LED5: Malfunction indicator lamp of inverter module. LED5 will be on and the LED4 will flash if the inverter module is faulty and the error code will display on digital tube by press query button.

LED6: Running indicator lamp of inverter module. The lamp will be on if the compressor is running.

LED7: Malfunction indicator lamp of inverter module. LED7 will be on and the LED6 will flash if the inverter module is faulty and the error code will display on digital tube by press query button.

8. AFTER-SALE SERVICE

If the air conditioner was operate abnormally, please plug off the power supply firstly, and contact with MUNDOCLIMA.



MUNDO  CLIMA[®]

ASK FOR MORE INFORMATION

Phone: (+34) 93 446 27 80

eMail: info@mundoclima.com

TECHNICAL ASSISTANCE

Phone: (+34) 93 652 53 57

www.mundoclima.com