

OUTDOOR UNIT

Installation and
owner's manual

MAXI MVD VR4+



CONTENTS

Installation manual	3
Owner's manual	24

INSTALLATION MANUAL

CONTENTS

PAGE

PRECAUTIONS.....	3
CONSTRUCTION CHECKPOINTS.....	4
ACCESSORIES.....	5
OUTDOOR UNIT INSTALLATION.....	5
REFRIGERANT PIPE.....	10
CONNECTING PIPE OF MS.....	16
MS WIRING NAMEPLATE.....	16
ELECTRIC WIRING.....	17
TRIAL RUN.....	23

1. PRECAUTIONS

Precautions before reading the Installation manual.

- This Installation manual is for the outdoor unit.
- Refer to the indoor unit Installation manual for indoor parts installation.
- Please read the power source unit Installation manual to install the power source unit.
- Please refer to the refrigerant distributor Installation manual to install the refrigerant distributor.

The safety precautions listed here are divided into two categories. In either case, important safety information is listed which must be read carefully.



WARNING

Failure to observe a warning may result in death. The appliance shall be installed in accordance with national wiring regulations.



CAUTION

Failure to observe a caution may result in injury or damage to the equipment.

After completing the installation, make sure that the unit operates properly during the start-up operation. Please instruct the customer on how to operate the unit and keep it trained. Also, inform customers that they should store this Installation manual along with the owner's manual for future reference.



WARNING

- **Be sure only trained and qualified service personnel to install, repair or service the equipment.**
Improper installation, repair, and maintenance may result in electric shocks, short-circuit, leaks, fire or other damage to the equipment.
- **Install according to this installation instructions strictly.**
If installation is defective, it will cause water leakage, electrical shock fire.

- **When installing the unit in a small room, take measures against to keep refrigerant concentration from exceeding allowable safety limits in the event of refrigerant leakage.**
Contact the place of purchase for more information. Excessive refrigerant in a closed ambient can lead to oxygen deficiency.
- **Use the attached accessories parts and specified parts for installation.**
Otherwise, it will cause the set to fall, water leakage, electrical shock fire.
- **Install at a strong and firm location which is able to withstand the set's weight.**
If the strength is not enough or installation is not properly done, the set will drop to cause injury.
- **The appliance shall be installed in accordance with national wiring regulations**
- **The appliance shall not be installed in the laundry.**
- **Before obtaining access to terminals, all supply circuits must be disconnected.**
- **The appliance must be positioned so that the plug is accessible.**
- **The enclosure of the appliance shall be marked by word, or by symbols, with the direction of the fluid flow.**
- **For electrical work, follow the local national wiring standard, regulation and this installation instructions. An independent circuit and single outlet must be used.**
If electrical circuit capacity is not enough or defect in electrical work, it will cause electrical shock fire.
- **Use the specified cable and connect tightly and clamp the cable so that no external force will be acted on the terminal.**
If connection or fixing is not perfect, it will cause heat-up or fire at the connection.
- **Wiring routing must be properly arranged so that control board cover is fixed properly.**
If control board cover is not fixed perfectly, it will cause heat-up at connection point of terminal, fire or electrical shock.
- **If the supply cord is damaged, it must be replaced by the manufacture or its service agent or similarly qualified person in order to avoid a hazard.**
- **An all-pole disconnection device which has at least 3mm separation distance in all pole and a residual current device(RCD)with the rating of above 10mA shall be incorporated in the fixed wiring according to the national rule**
- **When carrying out piping connection, take care not to let air substances go into refrigeration cycle.**
Otherwise, it will cause lower capacity, abnormal high pressure in the refrigeration cycle, explosion and injury.
- **Do not modify the length of the power supply cord or use of extension cord, and do not share the single outlet with other electrical appliances.**
Otherwise, it will cause fire or electrical shock.
- **Carry out the specified installation work after taking into account strong winds, typhoons or earthquakes.**
Improper installation work may result in the equipment falling and causing accidents.

- **The temperature of refrigerant circuit will be high, please keep the interconnection cable away from the copper tube.**
- **The power cord type designation is H07RN-F.**
Equipment complying with IEC 61000-3-12.
- **If the refrigerant leaks during installation, ventilate the area immediately.**
- **After completing the installation work, check that the refrigerant does not leak.**
Toxic gas may be produced if the refrigerant leaks into the room and comes into contact with a source of fire, such as a fan heater, stove or cooker.



CAUTION

- **This A/C is a kind of amenity unit. Don't install it at the place where for storing machine, precise instrument, food, plant, animal, artwork or any other special used occasion.**
- **Ground the air conditioner.**
Do not connect the ground wire to gas or water pipes, lightning rod or a telephone ground wire. Incomplete grounding may result in electric shocks.
- **Be sure to install an earth leakage breaker.**
Failure to install an earth leakage breaker may result in electric shocks.
- **Connect the outdoor unit wires , then connect the indoor unit wires.**
You are not allowed to connect the air conditioner with the power source until wiring and piping of the air conditioner are done.
- **While following the instructions in this Installation manual, install drain piping in order to ensure proper drainage and insulate piping in order to prevent condensation.**
Improper drain piping may result in water leakage and property damage.
- **Install the indoor and outdoor units, power supply wiring and connecting wires at least 1 meter away from televisions or radios in order to prevent image interference or noise.**
Depending on the radio waves, a distance of 1 meter may not be sufficient enough to eliminate the noise.
- **The appliance is not intended for use by young children or infirm persons without supervision.**
- **Young children should be supervised to ensure that they do not play with the appliance.**
- **Don't install the air conditioner in the following locations:**
 - There is petrolatum existing.
 - There is salty air surrounding (near the coast).
(Except for the models with corrosion-resistant function)
 - There is caustic gas (the sulfide, for example) existing in the air (near a hot spring).
 - The Volt vibrates violently (in the factories).
 - In buses or cabinets.
 - In kitchen where it is full of oil gas.
 - There is strong electromagnetic wave existing.

- There are inflammable materials or gas.
- There is acid or alkaline liquid evaporating.
- Other special conditions.
- **When the outdoor unit is under part load operation, there might be discontinuous sizzle from the inner system pipelines, and that's the sound of the flowing refrigerant.**
- **The insulation of the metal parts of the building and the air conditioner should comply with the regulation of National Electric Standard.**







2. CONSTRUCTION CHECKPOINTS

- Acceptance and Unpacking
 - After the machine arrives, check whether it is damaged during the shipment. If the surface or inner side of the machine is damaged, submit a written report to the shipping company.
 - Check whether the model, specification and quantity of the equipment conform to the contract.
 - After removing the outer package, please keep the operation instructions well and count the accessories.
- Refrigerant pipe
 - Check the model and name to avoid mistaken installation.
 - Only should be used refrigerant distributors supplied by Mundoclina.
 - The refrigerant pipes must have the specified diameter. Nitrogen of a certain pressure must be filled into the refrigerant pipe before welding.
 - The refrigerant pipe must undergo heat insulation treatment.
 - After the refrigerant pipe is installed completely, the indoor unit cannot be powered on before performing the airtight test and creating a vacuum. The air-side and liquid-side pipes must undergo the airtight test and vacuum extraction.
- Airtight test
The refrigerant pipe must undergo the airtight test [with 2.94 MPa(30kgf/cm²) nitrogen].
- Creating a vacuum
Be sure to use the vacuum pump to create a vacuum of the connective pipe at the air side and liquid side concurrently.
- Refrigerant replenishment
 - If the length is greater than the reference pipe, the refrigerant replenishment quantity for each system should be calculated through the formula obtained according to the actual length of pipe.
 - Record the refrigerant replenishment quantity, actual length of pipe and the height difference of the indoor & outdoor unit onto the operation confirmation table of the outdoor unit in advance for future reference.
- Electric wiring
 - Select the power supply capacity and wire size according to the design manual. The power cable of the air conditioner is generally thicker than the power cable of the motor.
 - In order to prevent misoperation of the air conditioner, do not interleave or entwine the power cable with the connection wires (low-voltage wires) of the indoor/outdoor unit.

- Power on the indoor unit after performing the airtight test and making a vacuum.
- For details of setting the address of the outdoor unit, see Outdoor unit address bits.
- Trial run
 - Before operation, remove the six pieces of PE foaming which are used at the rear of the unit for protecting the condenser. Be careful not to damage the fin. Otherwise, the heat exchange performance may be affected.
 - Perform the trial run only after the outdoor unit has been powered on for over 24 hours.

3. ACCESSORIES

Table.3-1

Name	Model	All of units	Outline	Function
Installation and owner's manual		1		Be sure to deliver it to the customer
Indoor unit owner's manual		1		Be sure to deliver it to the customer
Toggling flathead screw		1	—	For toggling of indoor and outdoor units
90° mouting elbow		1 (8HP, 10HP) 2 (12HP~16HP)	—	For connecting pipes
Seal plug		8	—	For pipe cleaning
Connective pipe accessory		1	 (used in 8HP~16HP)	Connect to the high-pressrue gas balance side
Connective pipe accessory		1	 (used in 8HP~16HP)	Connect to the liquid pipe side
Connective pipe accessory		1	 (used in 8HP,10HP,12HP)	Connect to the high-pressure gas pipe side
Connective pipe accessory		1	 (used in 14HP,16HP)	Connect to the high-pressure gas pipe side
Connective pipe accessory		2	 (used in 12HP)	Connect to the low-pressure gas pipe or liquid pipe side
Screw bag		1	—	Stored for service

4. OUTDOOR UNIT INSTALLATION

4.1 Outdoor unit combination

Table.4-1

HP	Mode	Max. indoor units nos.	HP	Mode	Max. indoor units nos.
8	8HP×1	13	22	10HP+12HP	36
10	10HP×1	16	24	10HP+14HP	39
12	12HP×1	20	26	10HP+16HP	43
14	14HP×1	23	28	14HP×2	46
16	16HP×1	26	30	14HP+16HP	50
18	8HP+10HP	29	32	16HP+16HP	53
20	10HP+10HP	33	34	10HP×2+14HP	56

Table.4-2

HP	Mode	Max. indoor units nos.	HP	Mode	Max. indoor units nos.
36	10HP×2+16HP	59	52	10HP×2+16HP×2	64
38	10HP+12HP+16HP	63	54	10HP+12HP+16HP×2	64
40	10HP+14HP+16HP	64	56	10HP+14HP+16HP×2	64
42	14HP×3	64	58	14HP×3+16HP	64
44	14HP×2+16HP	64	60	14HP×2+16HP×2	64
46	14HP+16HP×2	64	62	14HP+16HP×3	64
48	16HP×3	64	64	16HP×4	64
50	8HP+10HP+16HP×2	64			

4.2 Dimension of outdoor unit

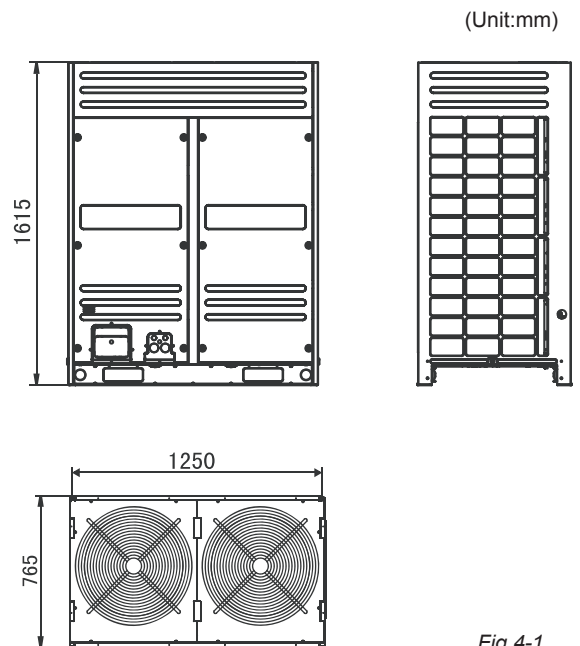

Fig.4-1

4.3 Selecting installation position

- Ensure that the outdoor unit is installed in a dry, well-ventilated place.
- Ensure that the noise and exhaust ventilation of the outdoor unit do not affect the neighbors of the property owner or the surrounding ventilation.
- Ensure that the outdoor unit is installed in a well-ventilated place that is possibly closest to the indoor unit.
- Ensure that the outdoor unit is installed in a cool place without direct sunshine exposure or direct radiation of high-temp heat source.
- Do not install the outdoor unit in a dirty or severely polluted place, so as to avoid blockage of the heat exchanger in the outdoor unit.
- Do not install the outdoor unit in a place with oil pollution or full of harmful gases such as sulfurous gas.
- Do not install the outdoor unit in a place surrounded by salty air. (Except for the models with corrosion-resistant function.)

4.4 Base for outdoor unit

- A solid, correct base can:
 - Avoid the outdoor unit from sinking.
 - Avoid the abnormal noise generated due to base.
- Base types
 - Steel structure base
 - Concrete base (see the figure below for the general making method)

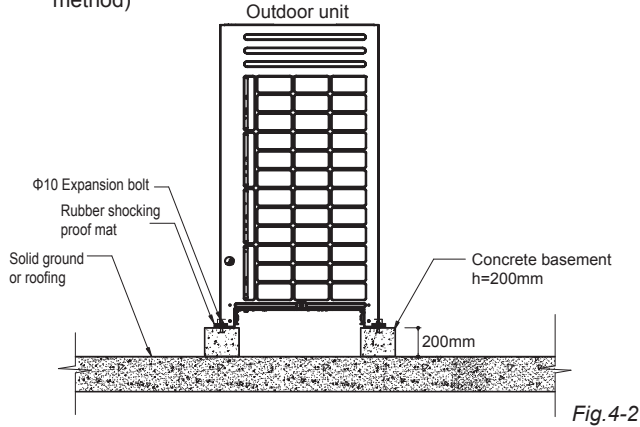

Fig. 4-2



CAUTION

- The key points to make basement:
 - The master unit's basement must be made on the solid concrete ground. Refer to the structure diagram to make concrete basement in detail, or make after field measurements.
 - In order to ensure every point can contact equality, the basement should be on completely level.
 - If the basement is placed on the roofing, the detritus layer isn't needed, but the concrete surface must be flat. The standard concrete mixture ratio is cement 1/ sand 2/ carpolite 4, and add Φ10 strenthen reinforcing steel bar, the surface of the cement and sand plasm must be flat, border of the the basement must be chamfer angle.
 - Before construct the unit base, please ensure the base is directly supporting the rear and front folding edges of the bottom panel vertically, for the reason of these edges are the actual supported sites to the unit.
 - In order to drain off the seeper around the equipment, a discharge ditch must be setup around the basement.
 - Please check the affordability of the roofing to ensure the load capacity.
 - When piping from the bottom of the unit, the base height should no less than 200mm.

- Position illustration of screw bolt (Unit: mm)

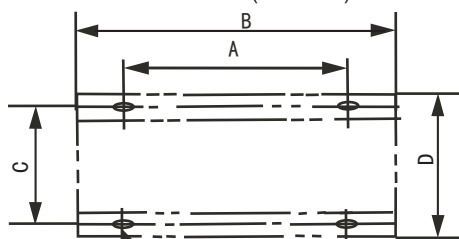

15×23 long u-shape hole Fig. 4-3

Table.4-3 Unit: mm

HP SIZE	8~16
A	1120
B	1250
C	736
D	765

- Centering position illustration of each connective pipe (Unit: mm)

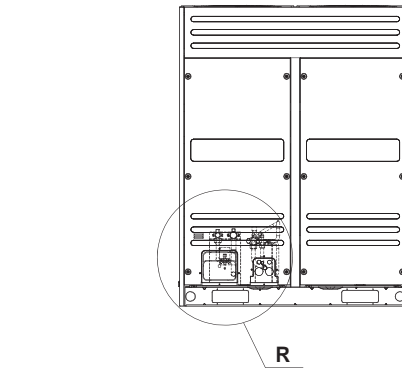
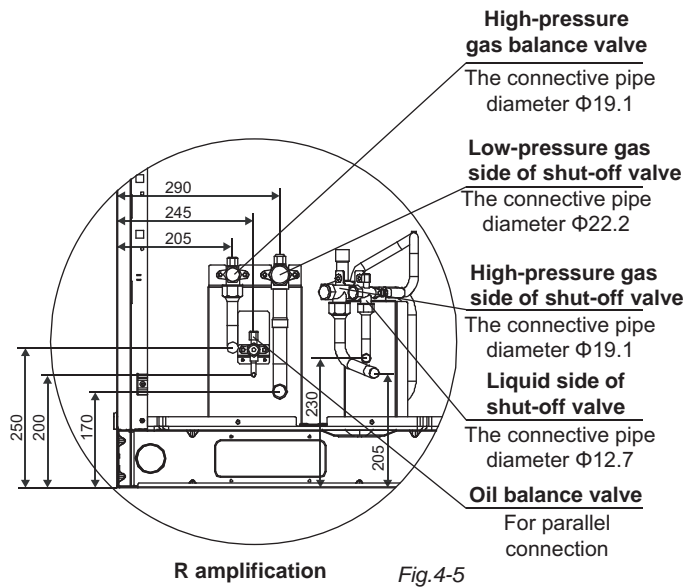

Fig. 4-4



R amplification Fig. 4-5

- 2) 12HP

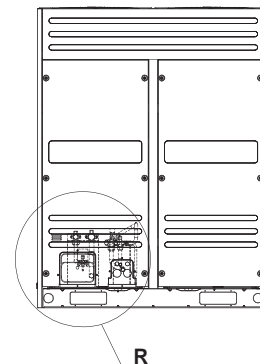
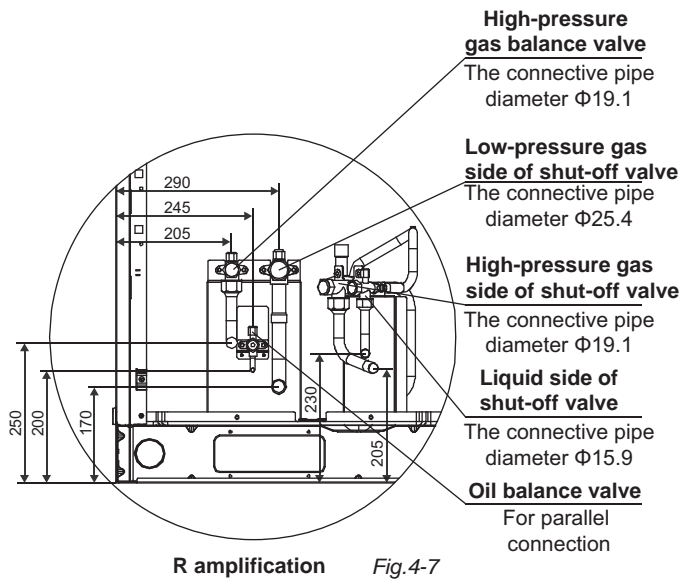
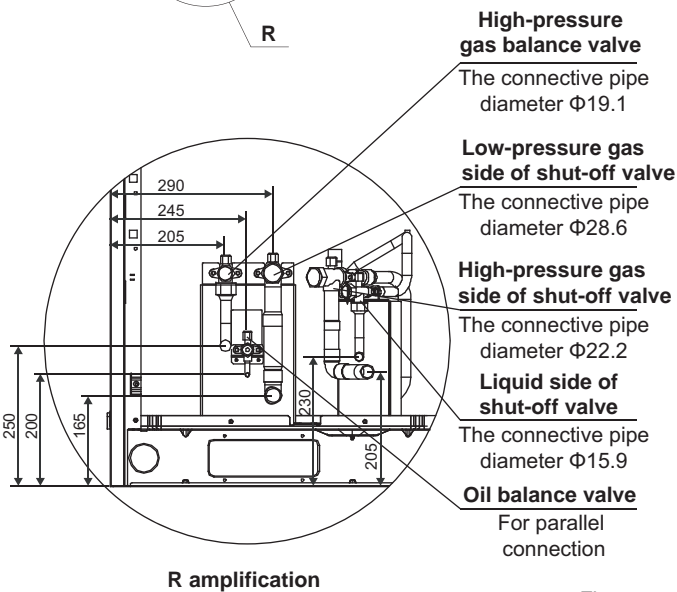
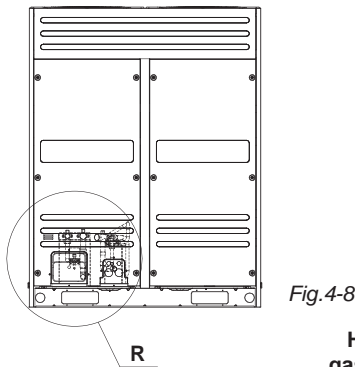

Fig. 4-6



3) 14HP, 16HP



4.5 Outdoor units' placement sequence & master and slave units' settings

A system, which provide with more than two outdoor units, will be set as the followings method: The outdoor units in this system should place sequentially from the large to the small capacity; the largest capacity outdoor unit must be mounted at the first branch joint site; and set the largest capacity outdoor unit address as the master Unit, while the other setting as the Slave Unit. Take 38HP (composed by 10HP, 12HP and 16HP) as an example:

- 1) Place the 16HP at a side of the first branch joint site.
- 2) Place the unit from the large capacity to the small (See the detail placement illustration)
- 3) Set 16HP as the main unit, while the 12HP and the 10HP as the aux. unit.

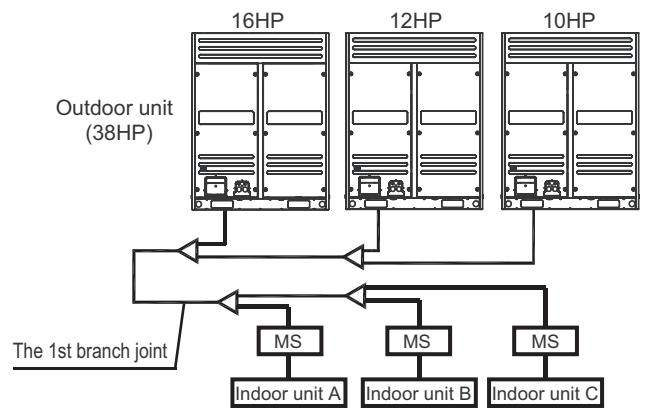
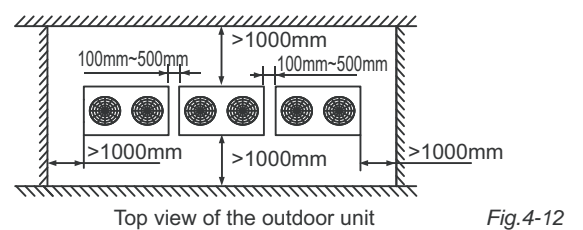
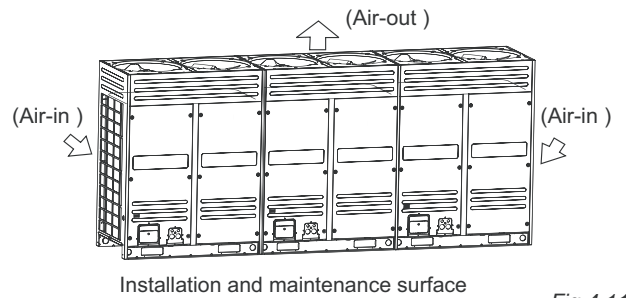

Fig.4-10

4.6 Installation space for outdoor unit

- Ensure enough space for maintenance. The modules in the same system must be on the same height.(see the Fig 4-11)
- When installing the unit, leave a space for maintenance shown in Fig.4-12 Install the power supply at the side of the outdoor unit. For installation procedure, see the power supply device Installation manual.
- In case any obstacles exist above the outdoor unit, refer to Fig.4-17.



4.7 Layout

- When the outdoor unit is higher than the surrounding obstacle
- One row

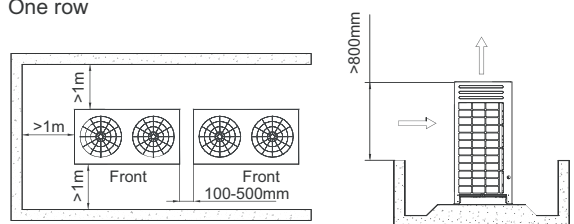

• Tow rows

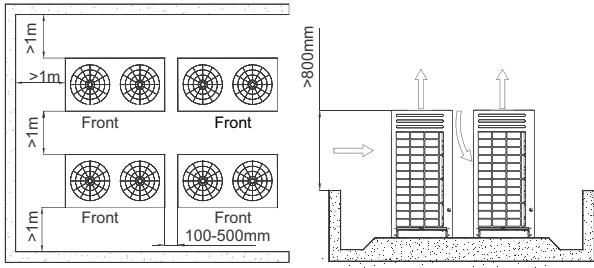

Fig.4-14

• More than two rows

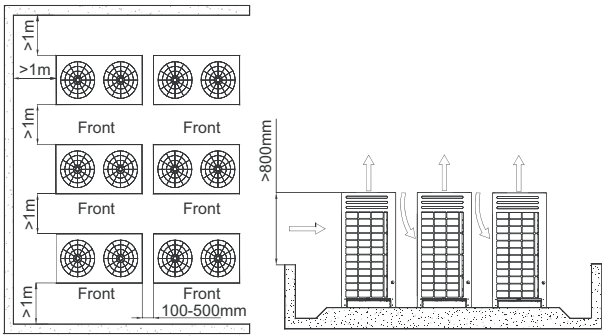

Fig.4-15

■ When the outdoor unit is lower than the surrounding obstacle, refer to the layout used when the outdoor unit is higher than the surrounding obstacle. However, to avoid cross connection of the outdoor hot air from affecting the heat exchange effect, please add an air director onto the exhaust hood of the outdoor unit to facilitate heat dissipation. See the figure below. The height of the air director is HD (namely H-h). Please make the air director on site.

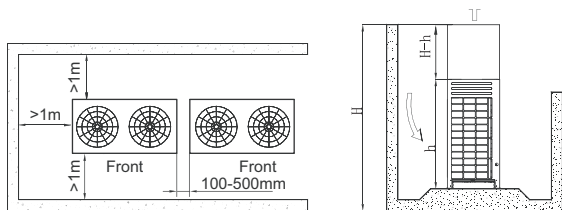
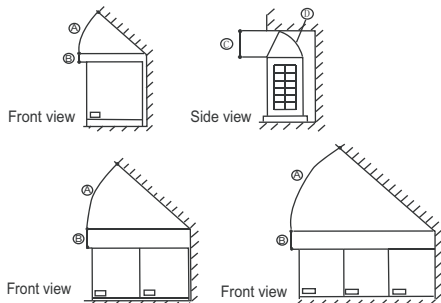

Fig.4-16

■ If miscellaneous articles are piled around the outdoor unit, such articles must be 800mm below the top of the outdoor unit. Otherwise, a mechanic exhaust device must be added.



- Ⓐ >45°
- Ⓑ >300mm
- Ⓒ >1000mm
- Ⓓ Airflow deflector

Fig.4-17

4.8 Set the snow-proof facility

■ In snowy areas, facilities should be installed to prevent snow. (See the figure below) (defective facilities may cause malfunction.) Please lift the bracket higher and install snow shed at the air inlet and air outlet.

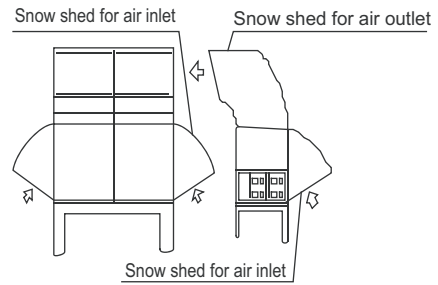

Fig.4-18

4.9 Explanation of valve

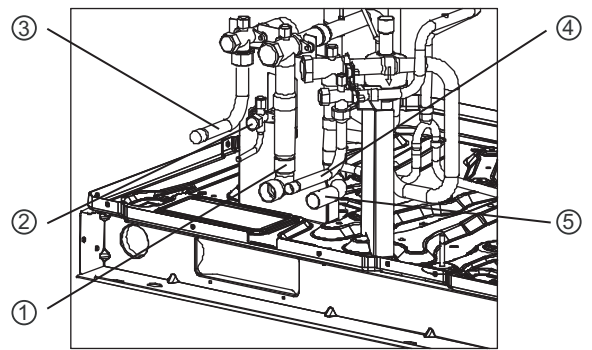

Fig.4-19

Table.4-4 Notes: 16HP as an example

①	Connect low-pressure gas pipe(accessory, field installation)
②	Connect oil balance pipe
③	Connect high-pressure gas balance pipe(accessory, field installation)
④	Connect liquid pipe(accessory, field installation)
⑤	Connect high-pressure gas pipe(accessory, field installation)

4.10 Mount the air deflector

■ Installation illustration

Example A

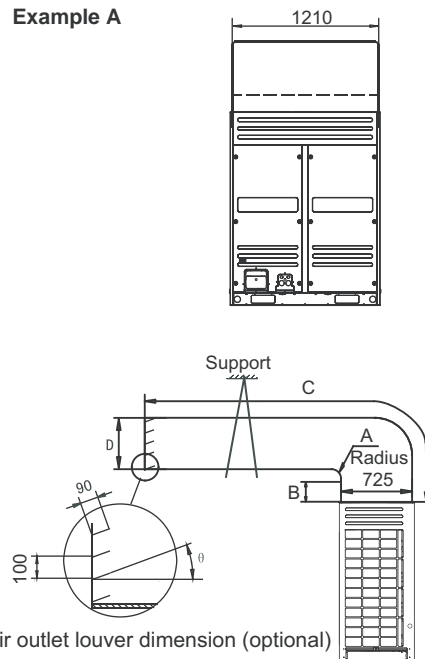

Fig.4-20

Fig.4-21

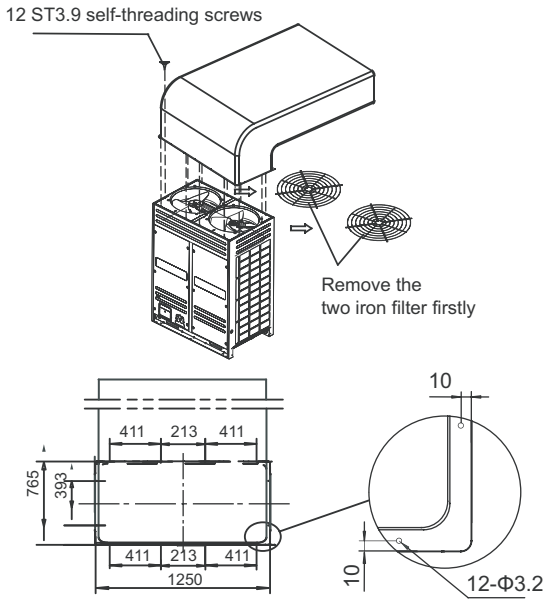

Fig. 4-22

Fig. 4-23

■ Curve diagram of static pressure, air flow volum.

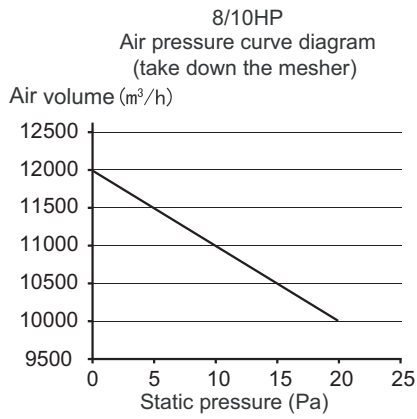

Fig. 4-24

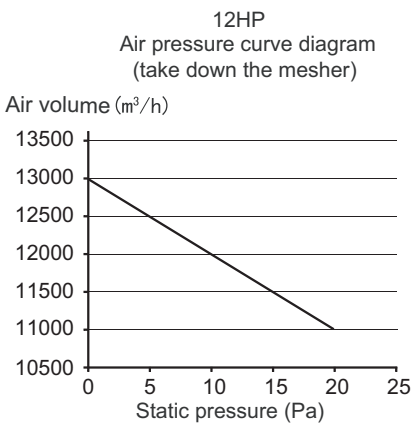

Fig. 4-25

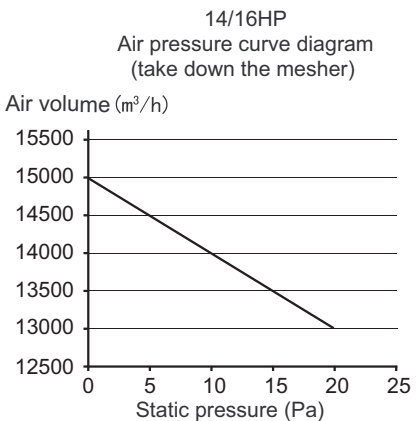

Fig. 4-26

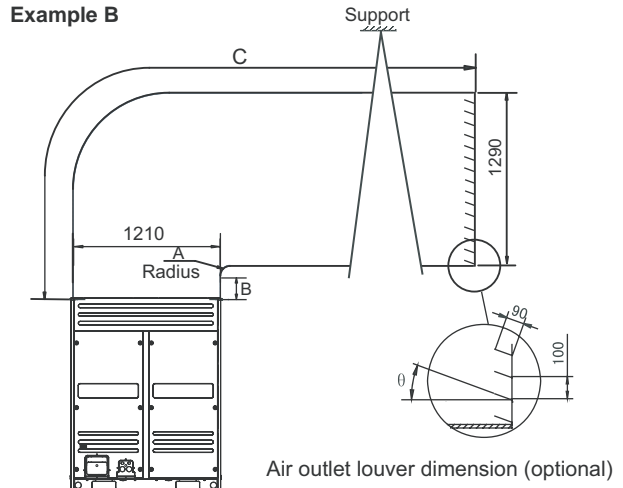

Fig. 4-27

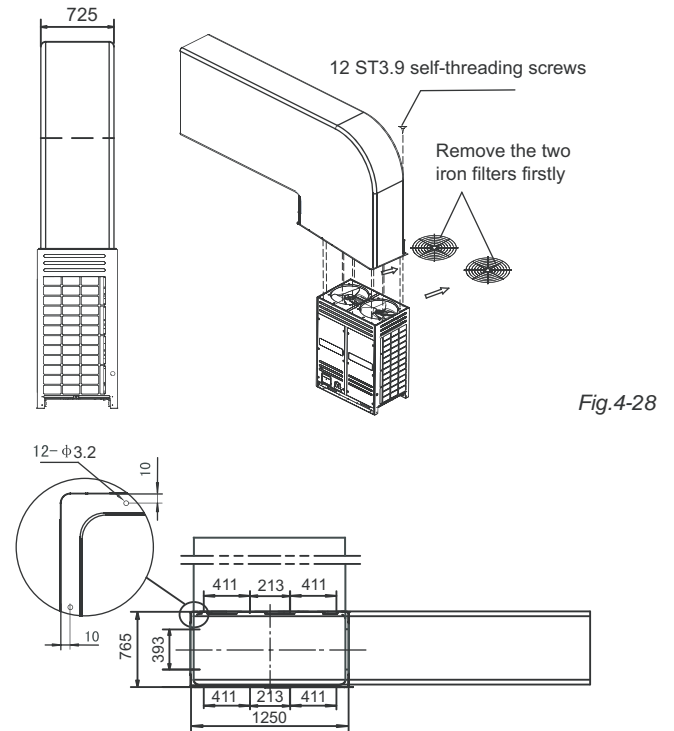

Fig. 4-28

Fig. 4-29

Table.4-5 Unit: mm

A	A ≥ 300
B	B ≥ 250
C	C ≤ 3000
D	725 ≤ D ≤ 760
θ	θ ≤ 15°

Table.4-6 Unit: mm

A	A ≥ 300
B	B ≥ 250
C	C ≤ 3000
θ	θ ≤ 15°



NOTE

- Before install the air deflector, please ensuring the mesh enclosure has been took off, otherwise the air supply efficiency would be block down.
- Once mounting the shutter to the unit, air volume, cooling (heating) capacity and efficiency would be block down, this affection enhance along with the angle of the shutter. Thus, we are not recommend you to mount the shutter, if necessary in use, please adjust the angle of shutter no larger than 15°.
- Only one bending site to be allowed in the air duct (see as above figure), otherwise, misoperation may led out.
- Install the flexible connector between the unit and the air pipe, for avoiding to produce vibration noise

5. REFRIGERANT PIPE

5.1 Length and drop height permitted of the refrigerant piping

Note: Assume equivalent pipe length of the branching pipe header to be 0.5m, of the MS to be 1m (for calculation purposes).

Table.5-1

		Permitted value	Piping
Pipe length	Total pipe length (Actual)	1000m (Please refer to the caution 5 of conditions 2)	$L1+(L2+L3+L4+L5+L6+L7+L8+L9+L10+L11+L12+L13) \times 2 + a+b+c+d+e+f+g+h+i+j+k+l+m+n$
	Maximum piping (L)	Actual length	175m
		Equivalent length	200m (Please refer to caution 1)
	Piping (farthest from the first line pipe branch) equivalent length		40m/90m (Please refer to caution 5)
MS to indoor unit equivalent length		40m	$j+k+n$
Drop height	Indoor unit to outdoor unit drop height	outdoor unit up	70m* (Please refer to caution 3)
		outdoor unit down	110m (Please refer to caution 4)
	Indoor unit to indoor unit drop height		30m

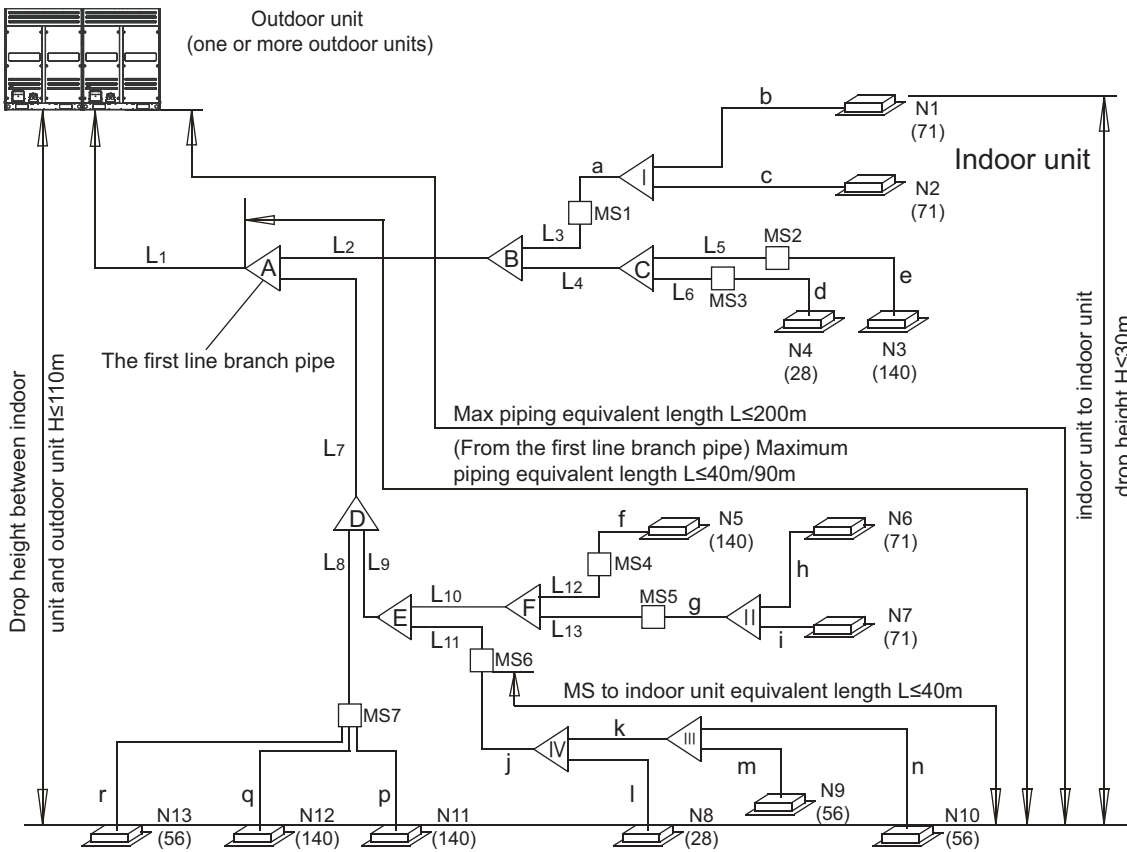

Fig.5-1

* Level difference above 70m are not supported by default but are available on request for customized, (if the outdoor unit is above the indoor unit.)

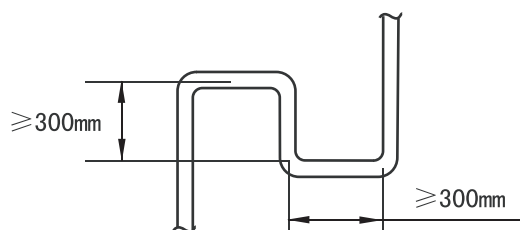

Fig.5-2

CAUTION

1. The reduced length of the branch joint is the 0.5m of the equivalent length.
2. The inner units should as equal as possible to be installed in the both sides of the U-shape branch joint.
3. When the outdoor unit is on the top position and the difference of level is over 20m, it is recommended that set a oil return bend every 10m in the air pipe of the main pipe, the specification of the oil return bend refers to Fig.5-2.
4. When the outdoor unit is on the low position, $H \geq 40m$, the liquid pipe of the main pipe need to increase one size.
5. The allowable length of the first branch joint which connected to the indoor unit should be equal to or shorter than 40m.
But when the following conditions are all metted, the allowable length can extended to 90m.

Conditions
1. It is needed to increase all the pipe diameters of the main distribution pipe which between the first and the last branch joint assembly. (Please change the pipe diameter at field) If the pipe diameter of the main slave pipe is the same as the main pipe, then it is not needed to be increased.
Examples
<ul style="list-style-type: none"> ■ $L7+L9+L11+j+k+n \leq 90m$ $L2 \sim L13$ need to increase the pipe diameter of the distribution pipe ■ Increasing size as the following <p> $\phi 9.5 \rightarrow \phi 12.7$ $\phi 12.7 \rightarrow \phi 15.9$ $\phi 15.9 \rightarrow \phi 19.1$ $\phi 19.1 \rightarrow \phi 22.2$ $\phi 22.2 \rightarrow \phi 25.4$ $\phi 25.4 \rightarrow \phi 28.6$ $\phi 28.6 \rightarrow \phi 31.8$ $\phi 31.8 \rightarrow \phi 38.1$ $\phi 38.1 \rightarrow \phi 41.3$ $\phi 41.3 \rightarrow \phi 44.5$ $\phi 44.5 \rightarrow \phi 54.0$ </p>

Conditions
2. When counting the total extended length, the actual length of above distribution pipes must be doubled. (Expect the main pipe and the distribution pipes which no need to be increased.) $L1+(L2+L3+L4+L5+L6+L7+L8+L9+L10+L11+L12+L13) \times 2 + a + b + c + d + e + f + g + h + i + j + k + l + m + n \leq 1000m$
Examples
Reference Figure. 5-1
Conditions
3. The length from the indoor unit to the nearest branch joint assembly or $MS \leq 40m$; $b, c, d, e, f, h, i, l, m, n, p, q, r \leq 40m$ (Pipe diameter requirements, please refers to table .5-8).
Examples
Reference Figure .5-1
Conditions
4. The distance difference between [the outdoor unit to the farthest indoor unit] and [the outdoor unit to the nearest indoor unit] is $\leq 40m$. The farthest indoor unit N10 The nearest indoor unit N11 $(L1+L7+L9+L11+j+k+n) - (L1+L7+L8+p) \leq 40m$
Examples
Reference Figure .5-1

5.2 Select the refrigerant piping type

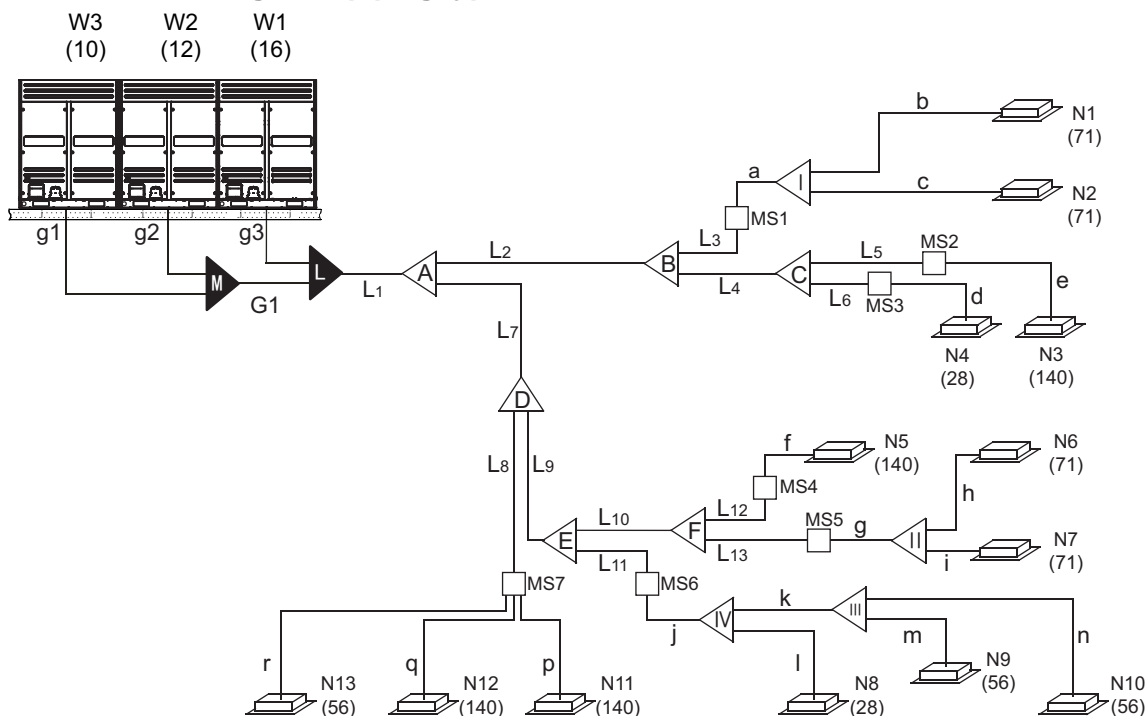

Fig.5-3

Table.5-2

Pipe name	Code (As per the Fig. 5-2)
Main pipe	L1
Indoor unit main pipe	L2~L13
Indoor unit aux. pipe	a, b,...r
Indoor unit main pipe branching pipe assembly	A, B, C, D, E
Indoor unit aux.pipe branching pipe assembly	I、II、III、IV
Outdoor unit branching pipe assembly	L, M
Outdoor unit connective pipe	g1, g2, g3, G1
MS equipment	MS1,...MS7

5.3 Size of joint pipes for indoor unit

Table.5-3 Size of joint pipes for R410A indoor unit

Capacity of indoor unit A(×100W)	Indoor unit main pipe(mm)			
	Low-pressure gas side	High-pressure gas side	Liquid side	Available branching pipe
A<56	Φ12.7	Φ9.5	Φ6.4	FQZHN-01SB
56≤A<166	Φ19.1	Φ15.9	Φ9.5	FQZHN-01SB
166≤A<230	Φ22.2	Φ19.1	Φ9.5	FQZHN-02SB
230≤A<330	Φ22.2	Φ19.1	Φ12.7	FQZHN-02SB
330≤A<460	Φ28.6	Φ22.2	Φ12.7	FQZHN-03SB
460≤A<660	Φ28.6	Φ22.2	Φ15.9	FQZHN-03SB
660≤A<920	Φ34.9	Φ28.6	Φ19.1	FQZHN-04SB
920≤A<1350	Φ41.3	Φ34.9	Φ19.1	FQZHN-05SB
1350≤A	Φ44.5	Φ38.1	Φ22.2	FQZHN-05SB

e.x.1: Refer to Fig.5-2, the capacity of downstream units to L2 is 71×2+140+28=310, i.e. low pressure gas pipe for L2 is Φ22.2,high pressure gas pipe is Φ19.1,high pressure liquid pipe is Φ12.7.

5.4 Size of joint pipes for outdoor unit

Base on the following tables, select the diameters of outdoor unit main connective pipe. In case of the main accessory pipe of indoor unit larger than outdoor unit main connective pipe, take the large one for the selection.

Table.5-4 Size of joint pipes for R410A outdoor unit

Model	When the equivalent length of all liquid pipes < 90m, the size of main pipe(mm)			
	Low-pressure gas side	High-pressure gas side	Liquid side	The 1st branching pipe for indoor unit
8HP	Φ22.2	Φ19.1	Φ9.5	FQZHN-02SB
10HP	Φ22.2	Φ19.1	Φ12.7	FQZHN-02SB
12HP	Φ25.4	Φ19.1	Φ12.7	FQZHN-03SB
14~16HP	Φ28.6	Φ22.2	Φ15.9	FQZHN-03SB
18~22HP	Φ31.8	Φ28.6	Φ15.9	FQZHN-03SB
24HP	Φ34.9	Φ28.6	Φ15.9	FQZHN-04SB
26~32HP	Φ34.9	Φ28.6	Φ19.1	FQZHN-04SB
34~48HP	Φ41.3	Φ34.9	Φ19.1	FQZHN-05SB
50~64HP	Φ44.5	Φ38.1	Φ22.2	FQZHN-05SB

Table.5-5 Size of joint pipes for R410A outdoor unit

Model	When the equivalent length of all liquid pipes ≥ 90m, the size of main pipe(mm)			
	Low-pressure gas side	High-pressure gas side	Liquid side	The 1st branching pipe for indoor unit
8HP	Φ22.2	Φ19.1	Φ12.7	FQZHN-02SB
10HP	Φ22.2	Φ19.1	Φ12.7	FQZHN-02SB
12HP	Φ25.4	Φ19.1	Φ15.9	FQZHN-03SB
14~16HP	Φ28.6	Φ22.2	Φ15.9	FQZHN-03SB
18~22HP	Φ31.8	Φ28.6	Φ19.1	FQZHN-03SB
24HP	Φ34.9	Φ28.6	Φ19.1	FQZHN-04SB
26~32HP	Φ34.9	Φ28.6	Φ22.2	FQZHN-04SB
34~48HP	Φ41.3	Φ34.9	Φ22.2	FQZHN-05SB
50~64HP	Φ44.5	Φ38.1	Φ25.4	FQZHN-05SB

5.5 Branch pipes for outdoor unit

Table.5-6

Model	Outdoor unit pipe connective opening dimension(mm)		
	Low-pressure gas side	High-pressure gas side	Liquid side
8~12HP	Φ22.2	Φ19.1	Φ12.7
14, 16HP	Φ28.6	Φ22.2	Φ15.9

5.6 Multi connecting pipe assembly and pipe diameter for outdoor unit

Base on Table 5-7 select the multi connecting pipe assembly of outdoor unit. Before installation, please read the Outdoor Unit Branching Pipe Installation Manual carefully.

Table.5-7 Outdoor unit multi connecting pipe assembly (Illustration)

Outdoor unit Qty.	Illustration	Outdoor unit connective pipe diameter	Parallel connect with the branching pipes
2 units		g1,g2: 8~12HP: Φ22.2/Φ19.1/Φ12.7 14, 16HP: Φ28.6/Φ22.2/Φ15.9	L: FQZHW-02SB
3 units		g1,g2,g3: 8~12HP: Φ22.2/Φ19.1/Φ12.7 14, 16HP: Φ28.6/Φ22.2/Φ15.9 G1:Φ34.9/Φ28.6/Φ19.1	L+M: FQZHW-03SB
4 units		g1,g2,g3,g4: 8~12HP: Φ22.2/Φ19.1/Φ12.7 14, 16HP: Φ28.6/Φ22.2/Φ15.9 G1:Φ34.9/Φ28.6/Φ19.1 G2:Φ41.3/Φ34.9/Φ22.2	L+M+N: FQZHW-04SB

5.7 Example

- 1) Take (10+12+16) HP that composed by three modules as an example to clarify the pipe selection.
- 2) Take Fig.5-2 as an example. Provided that the equivalent length of all pipes in this system is larger than 90m.

Table.5-8

Capacity of indoor unit A(×100W)	Indoor unit aux. pipe (between branch joint and branch joint/MS) (mm)		The branch pipe assembly of indoor unit aux. pipe	
	Gas side	Liquid side		
A<160	Φ15.9	Φ9.5	FQZHN-01D	
Capacity of indoor unit A(×100W)	Indoor unit aux. pipe(between indoor unit and branch joint/MS)(mm)			
	When branching pipe's length ≤10m		When branching pipe's length >10m	
	Gas side	Liquid side	Gas side	Liquid side
A<56	Φ12.7	Φ6.4	Φ15.9	Φ9.5
160≥A≥56	Φ15.9	Φ9.5	Φ19.1	Φ12.7

- A Branching pipe at the inside of the unit.
There are b,c,d,e,f,h,i,l,m,n,p,q,r branching pipes at the inside of the unit, the branching pipe diameter should be select as per Table 5-8.
- B Main pipe and aux.pipe at the inside of the unit (Refer to Table 5-3 and Table 5-8)
- 1) The aux. pipe a with N1, N2 downstream indoor units that total capacity is $71 \times 2 = 142$, the pipe a diameter is $\Phi 15.9 / \Phi 9.5$, this select FQZHN-01D for the branching pipe I.
 - 2) The main pipe L3 with N1, N2 downstream indoor units that total capacity is $71 \times 2 = 142$, the pipe L3 diameter is $\Phi 19.1 / \Phi 15.9 / \Phi 9.5$, this select MVD-MS02/N1-C for MS1.
 - 3) The main pipe L5 with N3 downstream indoor units that total capacity is 140, the pipe L5 diameter is $\Phi 19.1 / \Phi 15.9 / \Phi 9.5$, this select MVD-MS02/N1-C for MS2.
 - 4) The main pipe L6 with N4 downstream indoor units that total capacity is 28, the pipe L6 diameter is $\Phi 12.7 / \Phi 9.5 / \Phi 6.4$, this select MVD-MS02/N1-C for MS3.
 - 5) The main pipe L4 with N3, N4 downstream indoor units that total capacity is $140 + 28 = 168$, the pipe L4 diameter is $\Phi 22.2 / \Phi 19.1 / \Phi 9.5$, this select FQZHN-02SB for the branching pipe C.
 - 6) The main pipe L2 with N1~N4 downstream indoor units that total capacity is $71 \times 2 + 140 + 28 = 310$, the pipe L2 diameter is $\Phi 22.2 / \Phi 19.1 / \Phi 12.7$, this select FQZHN-02SB for the branching pipe B.
 - 7) The main pipe L12 with N5 downstream indoor units that total capacity is 140, the pipe L12 diameter is $\Phi 19.1 / \Phi 15.9 / \Phi 9.5$, this select MVD-MS02/N1-C for MS4.
 - 8) The aux. pipe g with N6, N7 downstream indoor units that total capacity is $71 \times 2 = 142$, the pipe g diameter is $\Phi 15.9 / \Phi 9.5$, this select FQZHN-01D for the branching pipe II.
 - 9) The main pipe L13 with N6, N7 downstream indoor units that total capacity is $71 \times 2 = 142$, the pipe L13 diameter is $\Phi 19.1 / \Phi 15.9 / \Phi 9.5$, this select MVD-MS02/N1-C for MS5.
 - 10) The main pipe L10 with N5~N7 downstream indoor units that total capacity is $140 + 71 \times 2 = 282$, the pipe L10 diameter is $\Phi 22.2 / \Phi 19.1 / \Phi 12.7$, this select FQZHN-02SB for the branching pipe F.
 - 11) The aux. pipe k with N9, N10 downstream indoor units that total capacity is $56 \times 2 = 112$, the pipe k diameter is $\Phi 15.9 / \Phi 9.5$, this select FQZHN-01D for the branching pipe III.
 - 12) The aux. pipe j with N8~N10 downstream indoor units that total capacity is $28 + 56 \times 2 = 140$, the pipe j diameter is $\Phi 15.9 / \Phi 9.5$, this select FQZHN-01D for the branching pipe IV.
 - 13) The main pipe L11 with N8~N10 downstream indoor units that total capacity is $28 + 56 \times 2 = 140$, the pipe L11 diameter is $\Phi 19.1 / \Phi 15.9 / \Phi 9.5$, thus select MVD-MS02/N1-C for MS6.
 - 14) The main pipe L9 with N5~N10 downstream indoor units that total capacity is $140 + 56 \times 2 + 71 \times 2 + 28 = 422$, the pipe L9 diameter is $\Phi 28.6 / \Phi 22.2 / \Phi 12.7$, thus select FQZHN-03SB for the branching pipe E.
 - 15) The main pipe L8 with N11~N13 downstream indoor units that total capacity is $140 \times 2 + 56 = 336$, the pipe L8 diameter is $\Phi 28.6 / \Phi 22.2 / \Phi 12.7$, this select MVD-MS04/N1-C for MS7.
 - 16) The main pipe L7 with N5~N13 downstream indoor units that total capacity is $140 \times 3 + 71 \times 2 + 56 \times 3 + 28 = 758$, the pipe L7 diameter is $\Phi 34.9 / \Phi 28.6 / \Phi 19.1$, this select FQZHN-04SB for the branching pipe D.
 - 17) The main pipe L1 with N1~N10 downstream indoor units that total capacity is $140 \times 4 + 71 \times 4 + 56 \times 3 + 28 \times 2 = 1064$, this select FQZHN-05SB for the branching pipe A.

- C Main pipe (Refer to Table 5-3, Table 5-5):
Main pipe L1 in the Fig.5-3, which upstream outdoor units total capacity is $16 + 12 + 10 = 38$, base on table 5-5, the low pressure gas/high pressure gas/liquid pipe diameter are $\Phi 41.3 / \Phi 34.9 / \Phi 22.2$, total capacity of the downstream indoor unit is $140 \times 4 + 71 \times 4 + 56 \times 3 + 28 \times 2 = 1064$, base on table 5-3, the low pressure gas/high pressure gas/liquid pipe diameter are $\Phi 41.3 / \Phi 34.9 / \Phi 19.1$, take the large one for your selection, final confirm the main pipe diameter is: low pressure gas/high pressure gas/liquid pipe $\Phi 41.3 / \Phi 34.9 / \Phi 22.2$.
- D Parallel connect the outdoor units
- 1) The outdoor unit linked by Pipe g1 is 10HP, parallel connects with outdoor unit. the connective pipe diameter to be selected according to its connector size is $\Phi 22.2 / \Phi 19.1 / \Phi 12.7$; The outdoor unit linked by Pipe g2 is 12HP, parallel connects with outdoor unit. the connective pipe diameter to be selected according to its connector size is $\Phi 22.2 / \Phi 19.1 / \Phi 12.7$; The outdoor unit linked by Pipe g3 is 16HP, parallel connects with outdoor unit. the connective pipe diameter to be selected according to its connector size is $\Phi 28.6 / \Phi 22.2 / \Phi 15.9$.
 - 2) G1 is the upstream of the two parallel connected outdoor units, refer to Table 5-7 select the two parallel connected outdoor unit, the pipe diameter is $\Phi 34.9 / \Phi 28.6 / \Phi 19.1$.
 - 3) Parallel connect the three outdoor units, refer to Table 5-7 should select FQZHW-03SB for outdoor unit connective pipes (L+M).

5.8 Caution for brazing

- Make sure to blow through with nitrogen when brazing. Blowing through with nitrogen prevents the creation of large quantities of oxidized film on the side of the pipe. An oxidized film adversely affects valves and compressors in the refrigerating system and prevents proper operation.
- The nitrogen pressure should be set to 0.02Mpa (i.e., just enough so it can be felt on the skin) with a pressure-reducing valve.

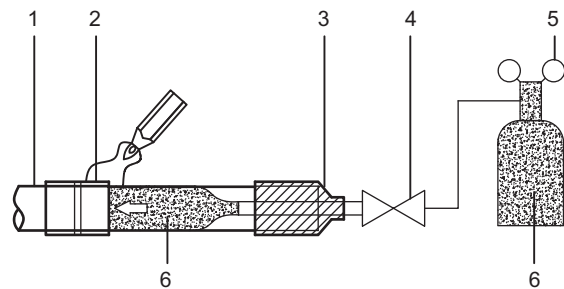

- 1 Refrigerant pipe
- 2 Part to be brazed
- 3 Taping
- 4 Hands valve
- 5 Pressure-reducing valve
- 6 Nitrogen

Fig.5-4

- Do not use anti-oxidants when brazing the pipe joints. Residue can clog pipes and break equipment.
- Do not use flux when brazing copper-to-copper refrigerant piping. Use phosphor copper brazing filler alloy (BCuP) which does not require flux.
- Flux has an extremely hardly influence on refrigerant pipe systems. For instance, if chlorine based flux is used, it will cause pipe corrosion or, in particular, if the flux contains fluorine, it will deteriorate the refrigerant oil.

5.9 Remove dirt or water in the piping

- Make sure there is no any dirt or water before connecting the piping to the outdoor units.
- Wash the piping with high pressure nitrogen, never use refrigerant of the outdoor unit.

5.10 Gas tight test

Charge 40kgf/cm² nitrogen gas from the piston of high-pressure gas side valve from the meter connector. Pressure inside should be maintained at there no less than 24 hrs.

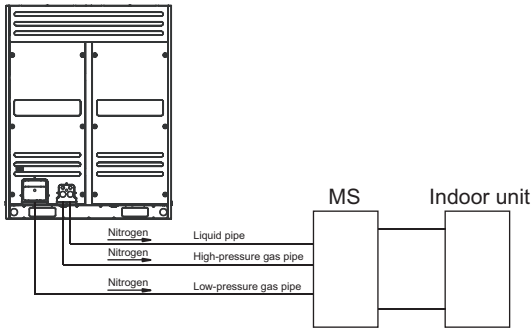

Fig.5-5

After the system is powered on, press the key of SW4 until displaying -000. And then press the key of forced cooling, UA is displayed.

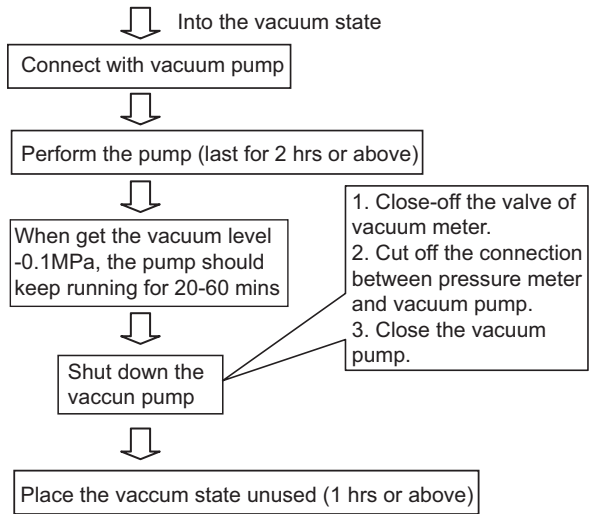

Fig.5-7



CAUTION

- Pressurized nitrogen (3.9MPa; 40kgf/cm²) is used for airtightness test.
- It is not allow to bring pressure on the float valve directly. (See Fig. 5-3)
- It is not allow to use oxygen, combustible gas or toxic gas to conduct the airtightness test.
- When welding, please use wet cloth insulating the low pressure valve for protection.
- For avoid the equipment be damaged, the pressure maintained time should not last too long.



CAUTION

- Don't mix up the different refrigerants or abuse the tools and measurements which directly contact with refrigerants.
- Don't adopt refrigerant gas for air vacuuming.
- If vacuum level could not get to -0.1MPa, please check whether resulted by leakage and confirm the leakage site. If no leakage, please operate the vacuum pump again 1 or 2 hrs.

5.11 Vacuum with vacuum pump

- 1) Use the vacuum pump which vacuum level lower than -0.1MPa and the air discharge capacity above 40L/min.
- 2) The outdoor unit is not necessary to vacuum, don't open the outdoor unit gas and liquid pipe shut-off valves.
- 3) Make sure the vacuum pump could result as -0.1MPa or below after 2 hrs or above operation. If the pump operated 3 hrs or above could not achieve to -0.1MPa or below, please check whether water mix or gas leak inside of the pipe.
- 4) Pressure gauge with the switch is installed between vacuum pump and system pipes.

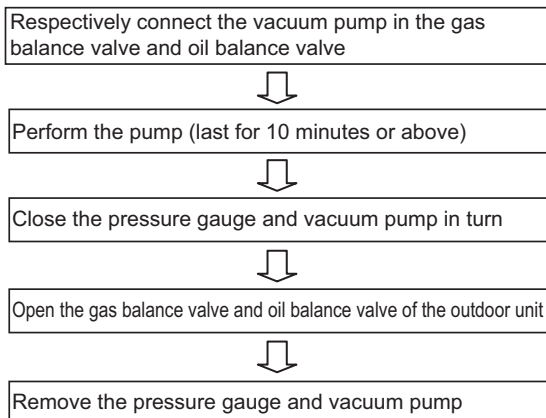

Fig.5-6

5.12 Refrigerant amount to be added

- 1) Calculate the added refrigerant according to the diameter and the length of the liquid side pipe of the outdoor/indoor unit connection. The refrigerant is R410A.

Note:

1. Assume equivalent pipe length of the branching pipe header to be 0.5m.
2. The refrigerant amount to be added of MS02 is 0.3kg/per, of MS04/MS06 is 0.5kg/per.

Table.5-9

Pipe size on liquid side	refrigerant to be Added per meter
Φ6.4	0.023kg
Φ9.5	0.060kg
Φ12.7	0.120kg
Φ15.9	0.180kg
Φ19.1	0.270kg
Φ22.2	0.380kg
Φ25.4	0.550kg
Φ28.6	0.710kg

- 2) Fill the additional quantity of calculated refrigerant from the low-pressure pipe and liquid pipe.
- 3) The system is back to electricity after power outages, and then quit from the vacuum state.

5.13 The Installation key points of connective pipes between outdoor units

- 1) Connect the pipes between outdoor units, the pipes should place horizontally (Fig.5-8, Fig.5-9), it is not allow the concave at junction site (Refer to Fig.5-10).
- 2) All connective pipes between the outdoor units are not allowed to over than the height of every outlets of the pipes (Refer to Fig.5-11).

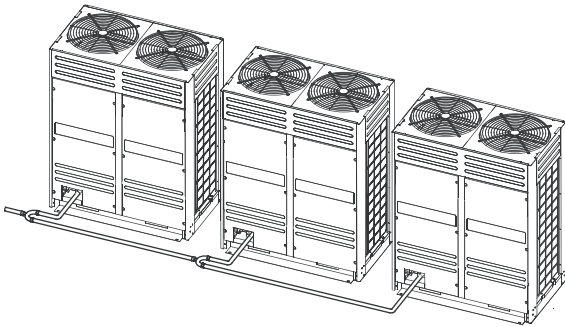

✓ Correct way

Fig.5-8

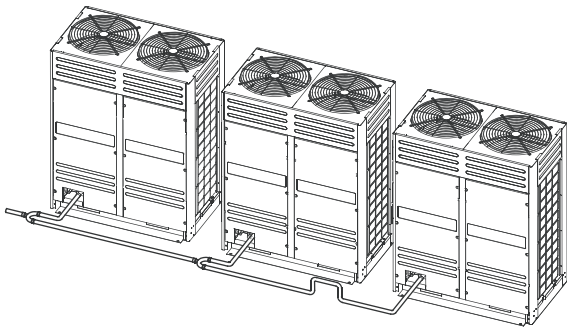

✓ Correct way

Fig.5-9

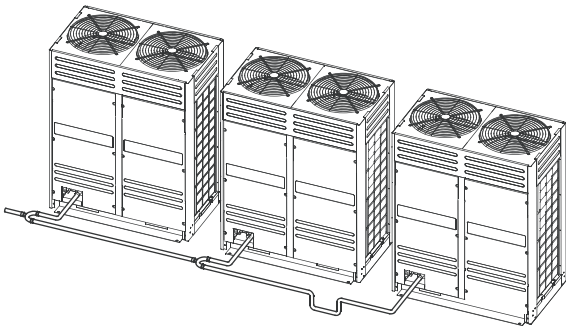

× Wrong way

Fig.5-10

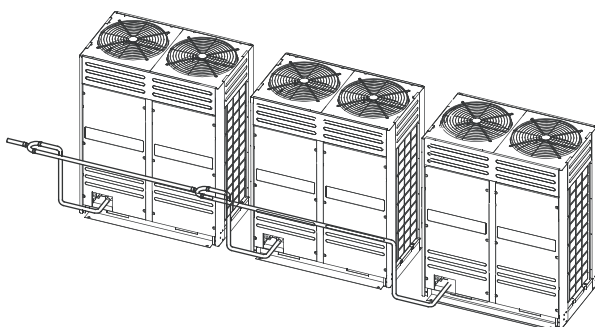

× Wrong way

Fig.5-11

- 3) The branching pipe must be installed horizontally, error angle of it should not large than 10°. Otherwise, malfunction will be caused.

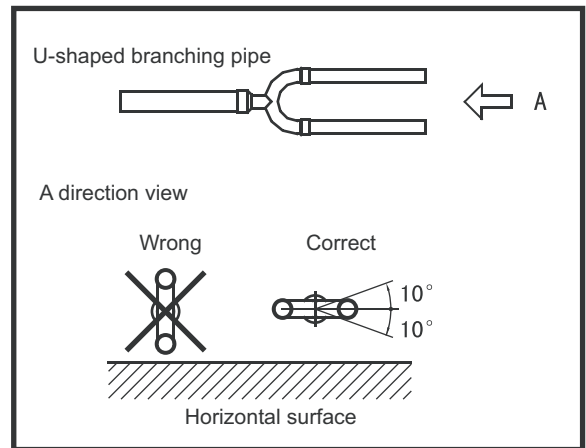

Fig.5-12

- 4) For avoid oil accumulate at the outdoor unit, please install the branching pipes properly.

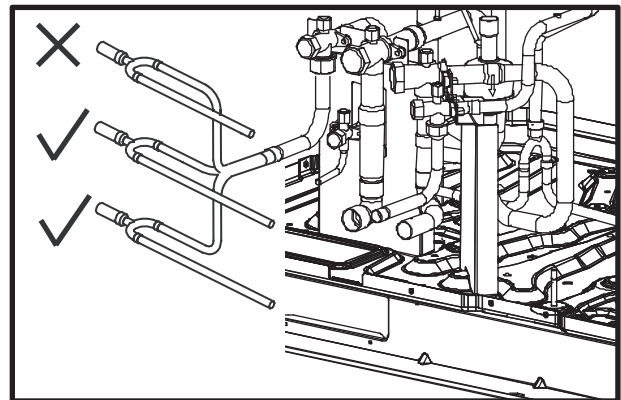

Fig.5-13

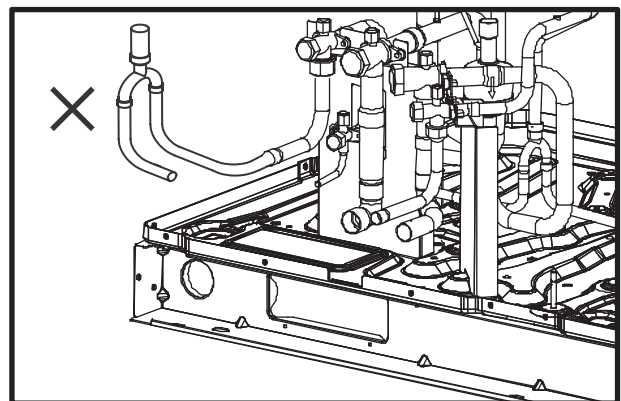

Fig.5-14

6. CONNECTING PIPE OF MS

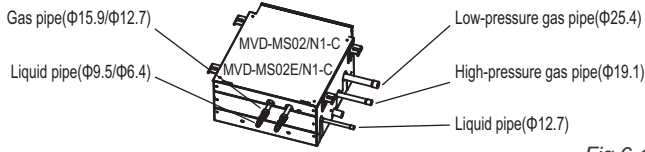

Fig.6-1

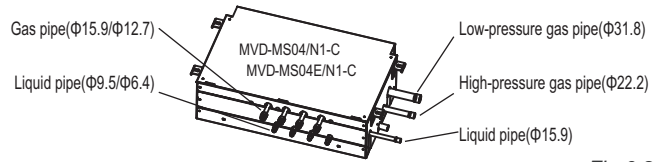

Fig.6-2

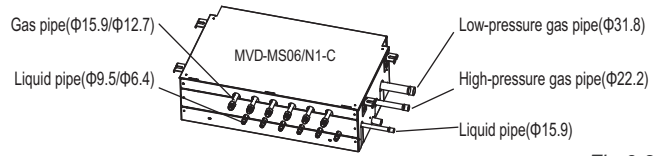

Fig.6-3

7. MS WIRING NAMEPLATE

7.1 The nameplate of MVD-MS(04,06)/N1-C

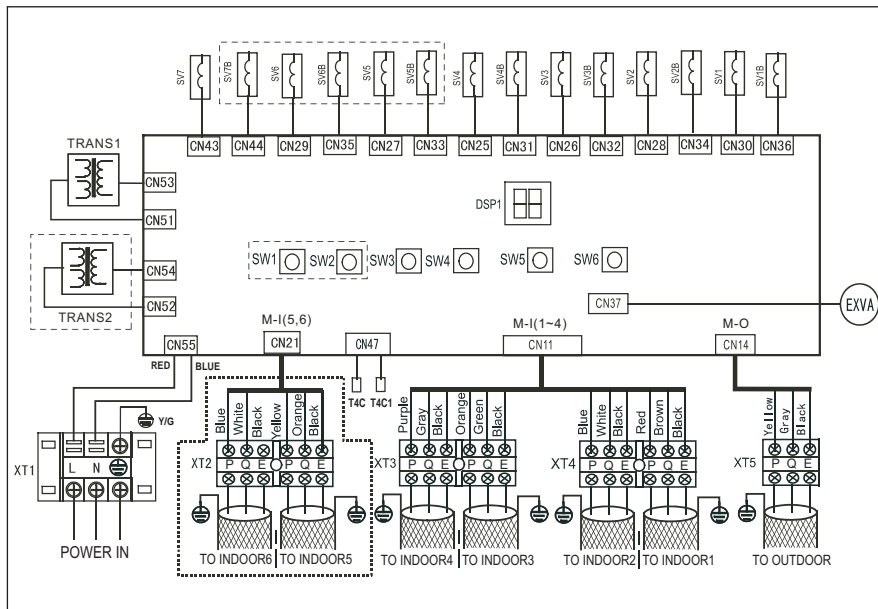

Fig.7-1

7.2 The nameplate of MVD-MS04E/N1-C (for connect only one indoor unit)

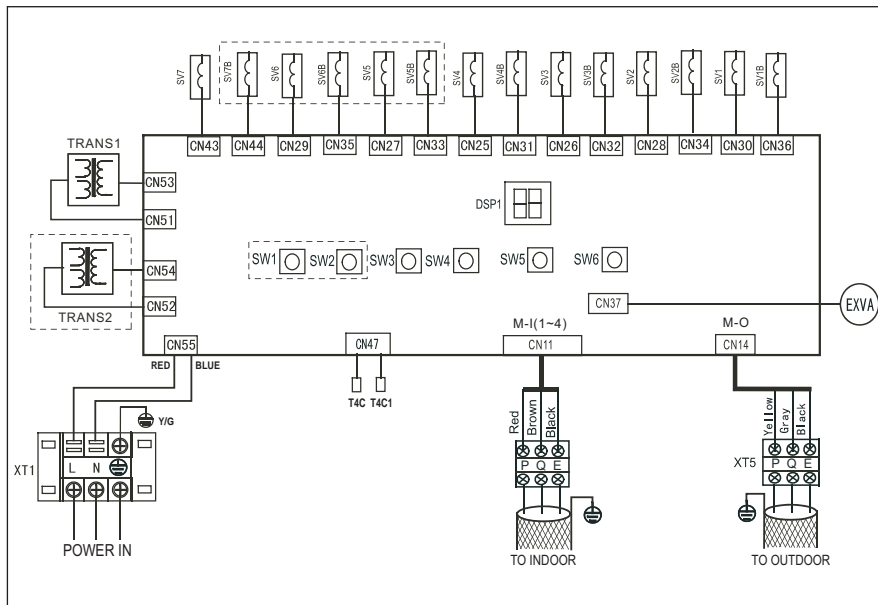

Fig.7-2

7.3 The nameplate of MVD-MS02/N1-C

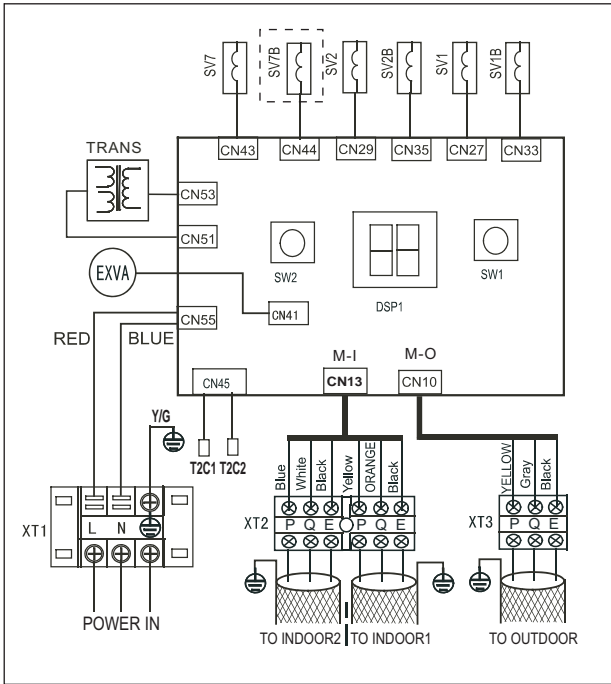

Fig.7-3

7.4 The nameplate of MVD-MS02E/N1-C (for connect only one indoor unit)

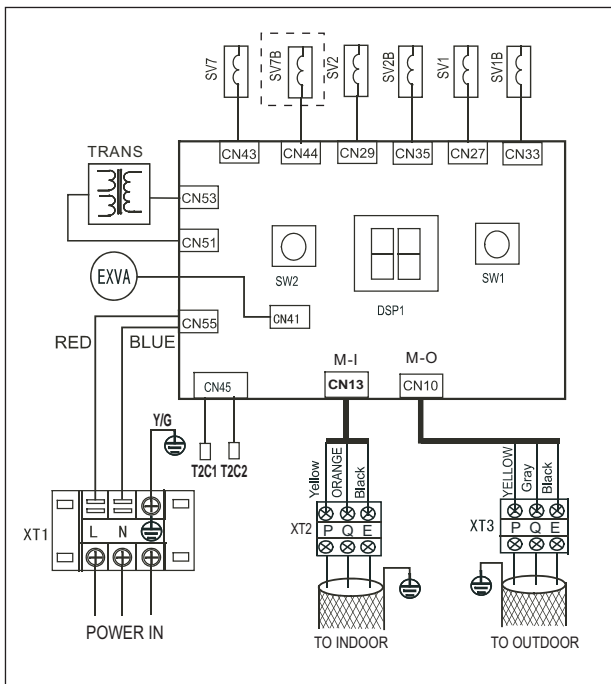

Fig.7-4

Table.7-1

Model of MS	MVD-MS02 /N1-C	MVD-MS04 /N1-C	MVD-MS06 /N1-C	MVD-MS02 E/N1-C	MVD-MS04 E/N1-C
Maximum capacity of single group pipe	16kW			—	
Maximum indoor units quantity of single group pipe	4			1	
Maximum capacity of MS	28kW	45kW	28kW	56kW	
Downstream of the largest length	40m				



NOTE

- single group pipe means a piece of liquid pipe and a piece of gas pipe.
- If the indoor units do not have auto mode function, then each group pipe of MS only can be connected 4 indoor units at most for one time; if the indoor units have auto mode function, then each group pipe of MS only can be connected 1 indoor unit at most for one time.
- Indoor units in the same group pipe of MS can not operate cooling and heating at the same time, or operate heating and air supplying at the same time, otherwise it will be modes conflict.
- Please install the MS at the places where do not have highly request for noise, such as the corridor or washroom and so on.
- The MS must be installed horizontally.
- There shall be at least 1m distance between the MS and the branch pipes while doing installation.
- There will be 30 seconds auto-checking function after the indoor and outdoor units have been started up.
- The indoor unit must use the remote controller for setting address, the addresses of the indoor units connected with the MS in the same system can not be the same (no matter whether connected with the same MS).

8. ELECTRIC WIRING

8.1 Terminal base function

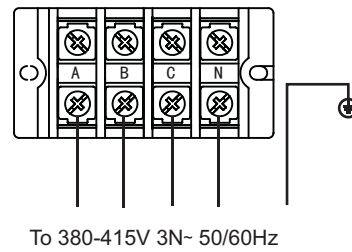

Fig.8-1

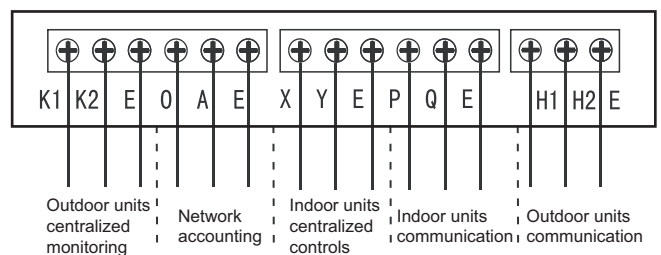

Fig.8-2

8.2 SW2 query instructions

Use application of the SW2 spot check

Table.8-1

No.	Normal display	Display content	Note
1	0. --	Outdoor unit address	0,1,2,3
2	1. --	Outdoor unit itself capacity	8,10,12,14,16
3	2. --	Modular outdoor unit qty.	Available for main unit
4	3. --	Operation mode	0,2,3,4,5,6
5	4. --	Total capacity of outdoor unit	Capacity requirement
6	5. --	Cooling capacity	Auxiliary unit only display capacity of main mode
7	6. --	Heating capacity	Auxiliary unit only display capacity of main mode
8	7. --	T4 ambient temp. revision of cooling capacity	
9	8. --	T4 ambient temp. revision of heating capacity	
10	9. --	The outdoor unit actual operation capacity	Capacity requirement
11	10. --	Speed of fan A	0, 1,……,14,15
12	11. --	Speed of fan B	0, 1,……,14,15
13	12. --	T2 average temp.	Actual value
14	13. --	T2B average temp.	Actual value
15	14. --	T3 pipe temp. (Left pipe temp.)	Actual value
16	15. --	T5 pipe temp. (Right pipe temp.)	Actual value
17	16. --	T4 ambient temp.	Actual value
18	17. --	Discharge temp.of inverter compressor A	Actual value
19	18. --	Discharge temp.of inverter compressor B	Actual value
20	19. --	Modual temp.	Actual value
21	20. --	Discharge pressure corresponding to the saturation temperature	Actual value+30
22	21. --	The minimum overheating temp. of discharge	Actual value
23	22. --	Current of inverter compressor A	Actual value
24	23. --	Current of inverter compressor B	Actual value
25	24. --	State of the evaporator or condenser	0,1,2,3
26	25. --	Opening angle of EXV A	Actual value+8
27	26. --	Opening angle of EXV B	Actual value+8
28	27. --	High pressure	Actual value×10
29	28. --	Qty. of indoor units	That can communicate with indoor units
30	29. --	Qty. of cooling indoor units	Actual value
31	30. --	Qty. of heating indoor units	Actual value
32	31. --	Reserve	
33	32. --	Night noise control mode	0,1,2,3
34	33. --	Static pressure mode	0,1,2,3
35	34. --	DC voltage A	Actual value+10
36	35. --	DC voltage B	Actual value+10
37	36. --	Reserve	
38	37. --	Reserve	Display code 8.8.8
39	38. --	Remove fault number of times	
40	39. --		Check end

The display contents as followings:

Normal display:

When standby, the high position displays the address of the outdoor unit, and the low position displays the Qty. of indoor units that can communicate with outdoor unit. When it is operating, it will display the rotation frequency of the compressor.

Operation mode:

0-Off; 2-Cooling; 3-Heating; 4-Forcing cooling; 5-Mixed cooling; 6-Mixed Heating.

Fan speed:

0-stop; 1~15 speed increase sequentially, 15 is the max. fan speed. EXV opening angle: Pulse count=Display value×8;

State of the evaporator or condenser:

0-close/condenser; 1-All evaporator; 2-Left evaporator/right condenser; 3-Left evaporator/close

Night noise control mode:

0-Night noise control mode; 1-silent mode; 2-Most silent mode; 3-No priority

Static pressure mode:

0-static pressure is 0 Mpa; 1-Low static pressure; 2-Medium static pressure; 3-High static pressure

8.3 Explanation of mainboard

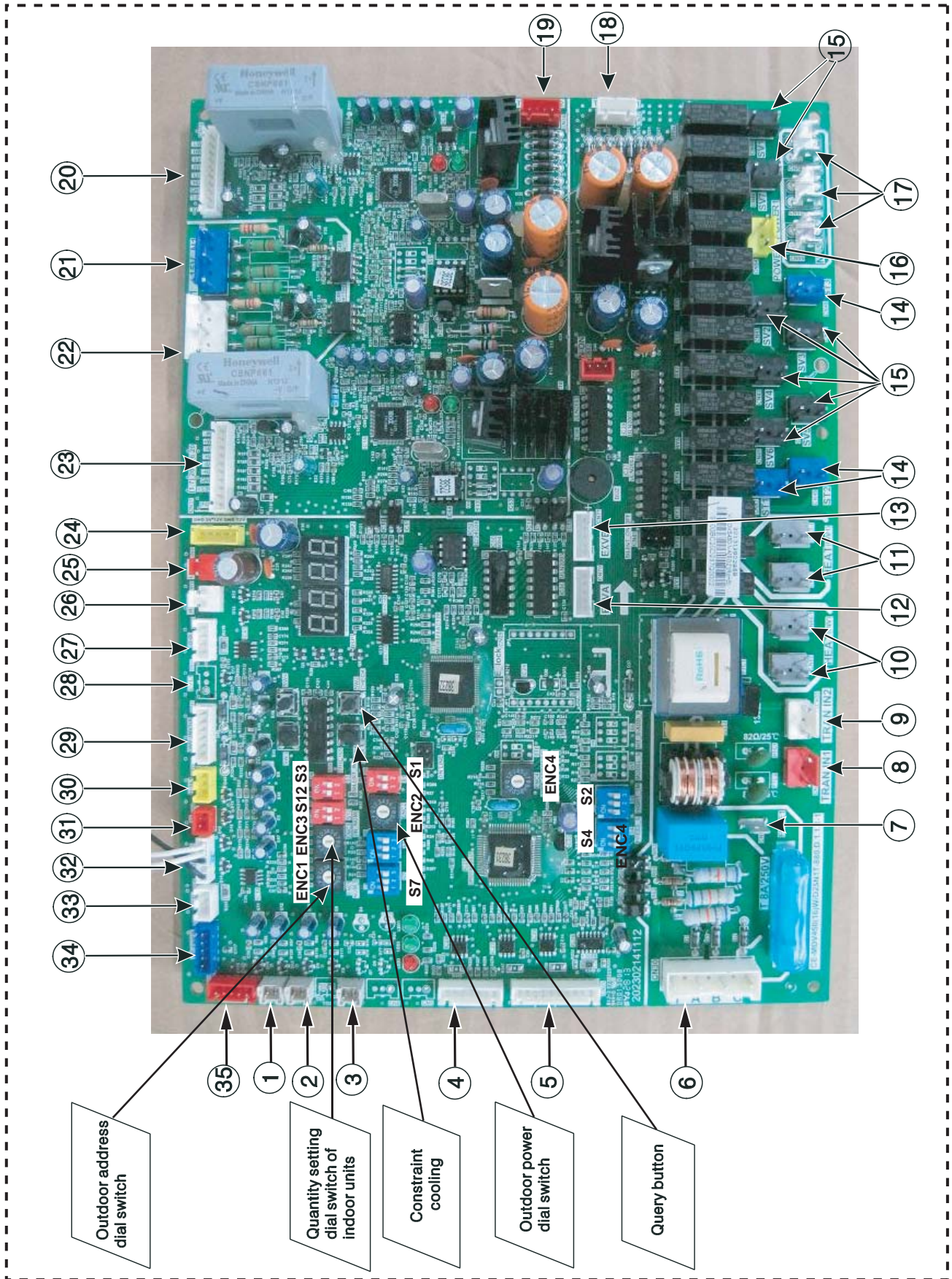
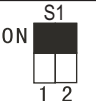
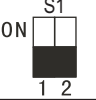

Fig.8-3

8.4 Dial codes definition



S1 definition

ON 	Starting time is set about 10 minutes
ON 	Starting time is set about 12 minutes (Default the Factory Set)

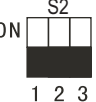
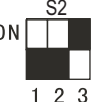
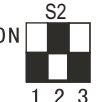
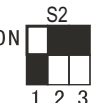
S2 definition

ON 	Night time selection is 6h/10h (Default the Factory Set)
ON 	Night time selection is 6h/12h
ON 	Night time selection is 8h/10h
ON 	Night time selection is 8h/12h

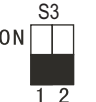
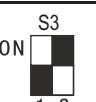
S3 definition

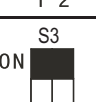
ON 	Night silent mode (Default the Factory Set)
ON 	Silent mode
ON 	Most silent mode
ON 	None silent mode



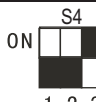
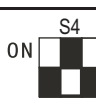
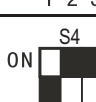





S4 definition

ON 	Static pressure mode is 0 MPa (Default the Factory Set)
ON 	Static pressure mode is low pressure(Reserve position, use for customized unit)
ON 	Static pressure mode is medium pressure(Reserve position, use for customized unit)
ON 	Static pressure mode is high pressure(Reserve position, use for customized unit)

S7 definition

ON 	Reserve
--	---------

ENC3 and S12 definition

ENC3 	S12 	Setting the numbers of indoor unit to be 0-15
ENC3 	S12 	Setting the numbers of indoor unit to be 16-31
ENC3 	S12 	Setting the numbers of indoor unit to be 32-47
ENC3 	S12 	Setting the numbers of indoor unit to be 48-63

ENC1 definition

ENC1 	Outdoor unit address setting switch Effective to 0-3 0 Stand for main unit 1-3 Stand for slave unit
--	---

ENC2 definition

ENC2 	Outdoor unit capacity setting switch Effective to 0-4 0-4 Stand for 8HP-16HP
--	---

ENC4 definition

ENC4 	Network address setting dial switch Effective to 0-7 0-7 stand for 0-7
--	---

■ Explanation of main board

Table.8-2

No.	Content
1	Discharge temp.sensed port of the inverter compressor A
2	Discharge temp.sensed port of the inverter compressor B
3	Temp.sensed port of the module
4	Reserve
5	Wiring port for communication between indoor and outdoor units,indoor unit network, outdoor unit network and network accounting
6	Three-phase detection port
7	Reserve
8	Power output of the No.1 transformer
9	Power output of the No.2 transformer
10	Heat output terminal of the inverter compressor A
11	Heat output terminal of the inverter compressor B
12	Exv A driving port
13	Exv B driving port
14	Four-way valve output terminal
15	One-way valve output terminal
16	Power control output terminal
17	Null line terminal
18	Power output of the No.1 transformer
19	Power output of the No.2 transformer
20	Activation port of inverter module B
21	Port for inverter module B voltage inspection
22	Port for inverter module A voltage inspection
23	Activation port of inverter module A
24	Power supply connected port of the main control panel
25	ON/OFF signal input port for system high pressure inspection
26	ON/OFF signal input port for system low pressure inspection
27	Reserve
28	Reserve
29	Current inspection port of the inverter compressors A and B
30	Input port for system high pressure inspection
31	Communication ports between outdoor units
32	Detection port for outdoor ambient temp.and left pipe Temp.
33	Detection port for right pipe Temp.
34	Control port of DC fan B
35	Control port of DC fan A

Notes:

1.The current value of combination unit is the total value of each basic model(refer to Table.8-3)

For example: 46HP=14HP+16HP*2

Power current: MCA=27.9+33.4*2=94.7
 TOCA=31.8+32.8*2=97.4
 MFA=35+35*2=105
 Compressor: RLA=(17.4+10.5)*3
 OFM: FLA=5.9+5.9*2=17.7

2. RLA is based on the following conditions.
Indoor temp. 27°C DB/19°C WB;Outdoor temp. 35°C DB
3. TOCA means the total value of each OC set.
4. MSC means the Max. current during the starting of compressor.
5. Voltage range
Units are suitable for use on electrical systems where voltage
6. Maximum allowable voltage variation between phase is 2%.
7. Selection wire size based on the larger value of MCA or TOCA
8. MFA is used to select the circuit breaker and the ground fault circuit interrupter (earth circuit breaker).

Remark:

- MCA: Min. Current Amps. (A)
- TOCA: Total Over-current Amps. (A)
- MFA: Max. Fuse Amps. (A)
- MSC: Max. Starting Amps. (A)
- RLA: Rated Locked Amps. (A)
- OFM:Outdoor Fan Motor.
- FLA: Full Load Amps. (A)
- KW: Rated Motor Output (kW)

8.5 Electric parameter form of outdoor unit

Table.8-3

System	Outdoor Unit				Power Current			Compressor		OFM	
	Voltage	Hz	Min.	Max.	MCA	TOCA	MFA	MSC	RLA	KW	FLA
8HP	380~415	50/60	342	440	18.4	20.8	25	—	17.4	0.42	3.6
								—	16.5		
								—	15.9		
10HP	380~415	50/60	342	440	20.6	22.1	25	—	17.4	0.42	3.6
								—	16.5		
								—	15.9		
12HP	380~415	50/60	342	440	21.8	22.8	25	—	17.4	0.42	3.6
								—	16.5		
								—	15.9		
14HP	380~415	50/60	342	440	27.9	31.8	35	—	17.4+10.5	0.71	5.9
								—	16.5+10.0		
								—	15.9+9.6		
16HP	380~415	50/60	342	440	33.4	32.8	35	—	17.4+10.5	0.71	5.9
								—	16.5+10.0		
								—	15.9+9.6		

8.6 Electric wiring of indoor/outdoor units



CAUTION

- Please select power supply for indoor unit and outdoor unit separately.
- The power supply should have specified branch circuit with leakage protector and manual switch.
- The power supply, leakage protector and manual of all the indoor units connecting to the same outdoor unit should be universal. (Please set all the indoor unit power supply of one system into the same circuit. It should turn on or shut down the unit at the same time, otherwise, the service life would affect seriously, even the unit may not turn on.)
- Please put the connective wiring system between indoor unit and outdoor unit with refrigerant piping system together.
- It is suggested to use 3-core shielded wire as signal wire between indoor and outdoor units, multi-core wire is unavailable.
- Please comply with relevant National Electric Standard.
- Power wiring should be done by professional electrician.

8.6.1 Outdoor unit power wiring

- With power facilities

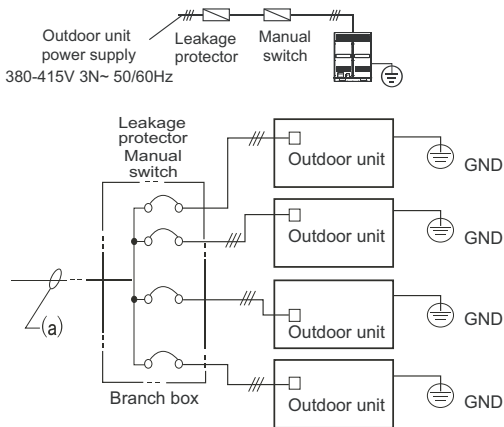

Fig.8-4

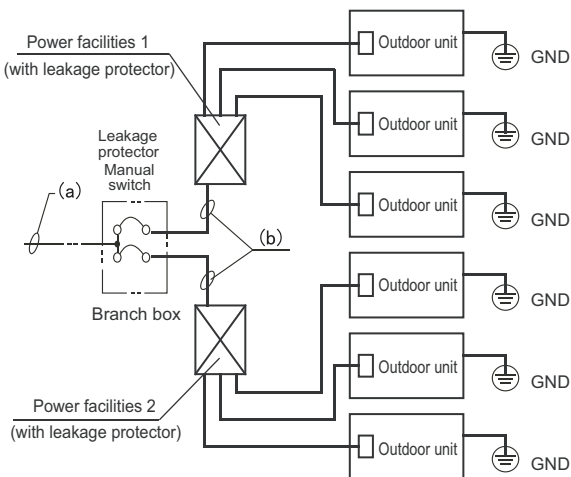

Fig.8-5

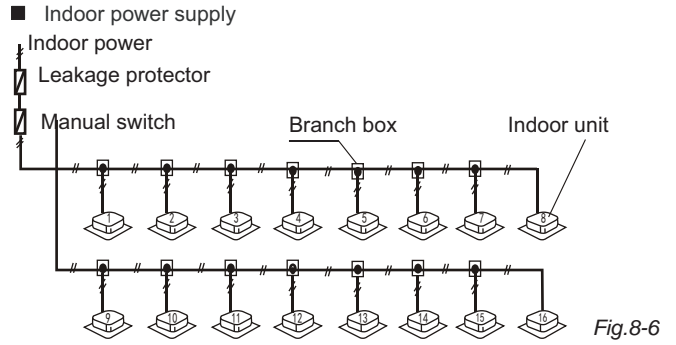

Fig.8-6



CAUTION

- Set refrigerant piping system, signal wires between indoor-indoor unit, and that between outdoor-outdoor unit into one system.
- Power must unified supply to all indoor units in the same system.
- Please do not put the signal wire and power wire in the same wire tube; keep distance between the two tubes. (Current capacity of power supply: less than 10A--300mm, less than 50A--500mm.)
- Make sure to set address of outdoor unit in case of parallel multi-outdoor units.

8.7 Signal wire of indoor/outdoor units

- Signal wire of indoor/outdoor unit adopts 3-core shielded wire ($\geq 0.75\text{mm}^2$) which has polarity, please connect it correctly.

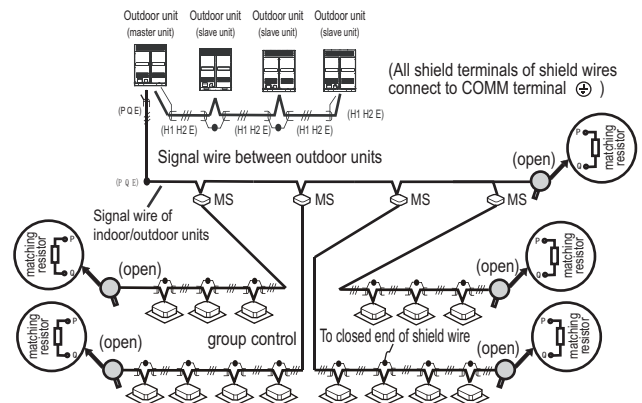

The indoor unit at the terminal of communication system should parallel connect a impedance between port P and port Q.

Fig.8-7

8.8 Example for power wire connection

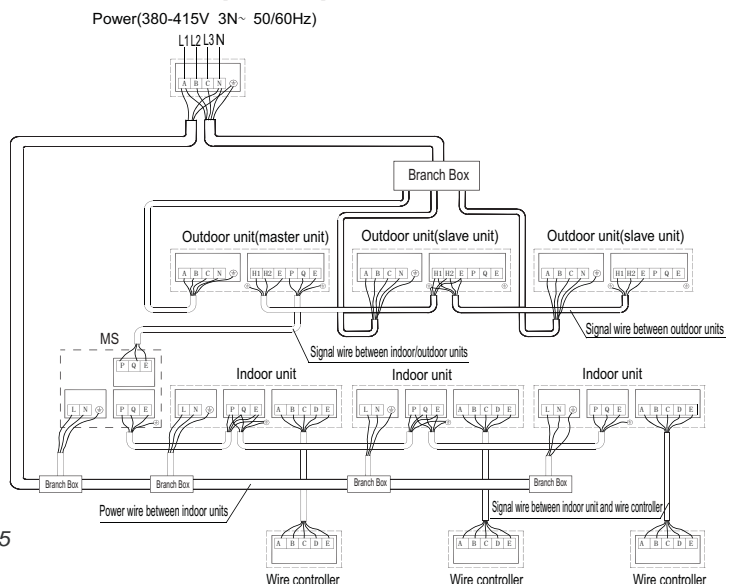

9. TRIAL RUN

9.1 Inspection and confirmation before debugging

- Check and confirm that refrigeration pipe line and communication wire with indoor and outdoor unit have been connected to the same refrigeration system. Otherwise, operation troubles shall happen.
- Power voltage is within ±10% of rated voltage.
- Check and confirm that the power wire and control wire are correctly connected.
- Check whether wire controller is properly connected.
- Before powering on, confirm there is no short circuit to each line.
- Check whether all units have passed nitrogen pressure-keeping test for 24 hours with R410A: 40kg/cm².
- Confirm whether the system to debugging has been carried out vacuum drying and packed with refrigeration as required.

9.2 Preparation before debugging

- Calculating the additional refrigerant quantity for each set of unit according to the actual length of liquid pipe.
- Keep required refrigerant ready.
- Keep system plan, system piping diagram and control wiring diagram ready.
- Record the setting address code on the system plan.
- Turn on power switches outdoor unit in advance, and keep connected for above 12 hours so that heater heating up refrigerant oil in compressor.
- Turn on air pipe stop valve, liquid pipe stop valve, oil balance valve and air balance valve totally. If the above valves do not be turned on totally, the unit should be damaged.
- Check whether the power phase sequence of outdoor unit is correct.
- All dial codes of indoor and outdoor unit have been set according to the Technical Requirement of Product.

9.3 Fill the name of connected system

To clearly identify the connected systems between two or more indoor units and outdoor unit, select names for every system and record them on the nameplate on the outdoor electric control box cover.

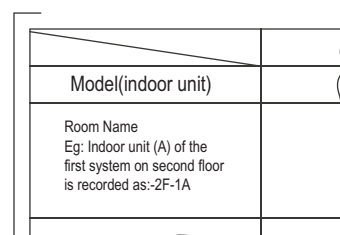

Fig.9-1

9.4 Caution on refrigerant leakage

- This air conditioner adopts R410A as refrigerant, which is safe and noncombustible.
- The room for air conditioner should be big enough that refrigerant leakage can not reach the critical thickness. Besides this, you can take some action on time.
- Critical thickness-----the max thickness of Freon without any harm to person. R410A critical thickness:0.3 [kg/m³]

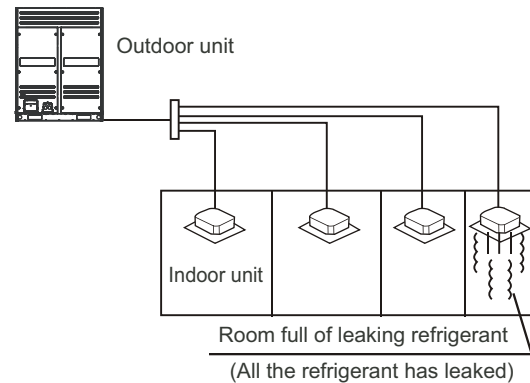

Fig.9-2

- Calculate the critical thickness through following steps, and take necessary actions.
- Calculate the sum of the charge volume (A[kg])
Total refrigerant volume=refrigerant volume when delivered(nameplate)+superaddition
- Calculate the indoor cubage (B[m³]) (as the minimum cubage)
- Calculate the refrigerant thickness.

$$\frac{A \text{ [kg]}}{B \text{ [m}^3\text{]}} \leq \text{Critical thickness: } 0.3 \text{ [kg/m}^3\text{]}$$

- Countermeasure against overhigh thickness
- Install mechanical ventilator to reduce the refrigerant thickness under critical level. (ventilate regularly)
- Install leakage detector alarming device related to mechanical ventilator if you can not regularly ventilate.

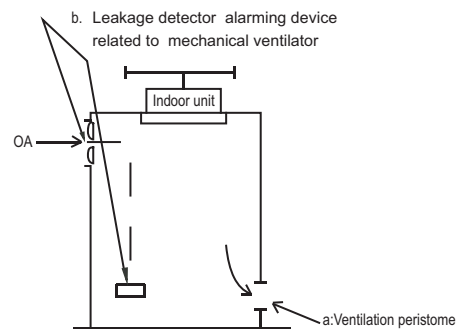

Fig.9-3

9.5 Turn over to customer

Be sure to deliver the Installation Manual of the indoor unit, and the outdoor unit to the user.

OWNER'S MANUAL

CONTENTS

PAGE

IMPORTANT SAFETY INFORMATION.....	24
PARTS NAMES.....	25
OPERATION AND PERFORMANCE.....	25
TROUBLES AND CAUSES.....	26
MALFUNCTION.....	28
CONSTRAINT COOLING AND QUERY.....	29
AFTER-SALES SERVICE.....	30

1. IMPORTANT SAFETY INFORMATION

To prevent injury to the user or other people and property damage, the following instructions must be followed. Incorrect operation due to ignoring of instructions may cause harm or damage.

The safety precautions listed here are divided into two categories. In either case, important safety information is listed which must be read carefully.



WARNING

Failure to observe a warning may result in death. The appliance shall be installed in accordance with national wiring regulations.



CAUTION

Failure to observe a caution may result in injury or damage to the equipment.



WARNING

- **Never touch the air outlet or the horizontal blades while the swing flap is in operation.**
Fingers may become caught or the unit may break down.
- **The appliance shall be installed in accordance with national wiring regulations**
- **Never inspect or service the unit by yourself.**
Ask a qualified service person to perform this work.
- **Do not dispose this product as unsorted municipal waste. Collection of such waste separately for special treatment is necessary.**
- **Do not dispose of electrical appliances as unsorted municipal waste, use separate collection facilities.**
Contact you local government for information regarding the connection systems available.
- **If electrical appliances are disposed of in landfills or dumps, hazardous substances can leak into the groundwater and get into the food chain, damaging your health and well-being.**
- **Keep far away from high-frequency equipment.**
- **Keep away from the following places:**
a place where it is full of oil gas; a place where salty air surrounding or near the coast (except for the models with corrosion-resistant function); a place where is caustic gas(the sulfide in hot spring). Location in the following places may cause malfunction or shorten the life span of the machine.
- **In the case of extremely strong wind, please prevent the air from flowing backwards into the outdoor unit.**
- **Snow canopy is necessary in snowfall places on the outdoor unit. Please consult the local dealer for details.**
- **In the frequent thunderstruck place, lightningproof actions should be taken.**
- **To prevent refrigerant leak, contact your dealer.**
When the system is installed and runs in a small room, it is required to keep the concentration of the refrigerant, if by any chance coming out, below the limit. Otherwise, oxygen in the room may be affected, resulting in a serious accident.
- **The refrigerant in the air conditioner is safe and normally does not leak.**
If the refrigerant leaks in the room, contact with a fire of a burner, a heater or a cooker may result in a harmful gas.
- **Turn off any combustible heating devices, ventilate the room, and contact the dealer where you purchased the unit.**
Do not use the air conditioner until a service person confirms that the portion where the refrigerant leaks is repaired.
- **Ask your dealer for installation of the air conditioner.**
Incomplete installation performed by yourself may result in a water leakage, electric shock, and fire.
- **Ask your dealer for improvement, repair, and maintenance.**
Incomplete improvement, repair, and maintenance may result in a water leakage, electric shock, and fire.
- **In order to avoid electric shock, fire or injury, or if you detect any abnormality such as smell of fire, turn off the power supply and call your dealer for instructions.**
- **Never replace a fuse with that of wrong rated current or other wires when a fuse blows out.**
Use of wire or copper wire may cause the unit to break down or cause a fire.
- **Do not insert fingers, rods or other objects into the air inlet or outlet.**
When the fan is rotating at high speed, it will cause injury.
- **Never use a flammable spray such as hair spray, lacquers paint near the unit.**
It may cause a fire.





CAUTION

- **Do not use the air conditioner for other purposes.**
In order to avoid any quality deterioration, do not use the unit for cooling precision instruments, food, plants, animals or works of art.
- **Before cleaning, be sure to stop the operation, turn the breaker off or pull out the supply cord.**
Otherwise, an electric shock and injury may result.
- **In order to avoid electric shock or fire, make sure that an earth leak detector is installed.**
- **Be sure the air conditioner is grounded.**
In order to avoid electric shock, make sure that the unit is grounded and that the earth wire is not connected to gas or water pipe, lightning conductor or telephone earth wire.
- **In order to avoid injury, do not remove the fan guard of the outdoor unit.**
- **Do not operate the air conditioner with a wet hand.**
An electric shock may happen.
- **Do not touch the heat exchanger fins.**
These fins are sharp and could result in cutting injuries.
- **After a long use, check the unit stand and fitting for damage.**
If damaged, the unit may fall and result in injury.
- **To avoid oxygen deficiency, ventilate the room sufficiently if equipment with burner is used together with the air conditioner.**
- **Arrange the drain hose to ensure smooth drainage.**
Incomplete drainage may cause wetting of the building, furniture etc.
- **Never expose little children, plants or animals directly to the air flow.**
Adverse influence to little children, animals and plants may result.
- **Notice to avoid places where operation noise may easily be spread away or be enhanced.**
- **Noise can be amplified by anything blocking the air outlet of outdoor unit.**
- **Choose a proper place that the noise and hot or cold wind blown out of the outdoor unit will not bring inconvenience to your neighbors and not affect the growth or animal or plant.**
- **Do not allow a child to mount on the outdoor unit or avoid placing any object on it.**
Falling or tumbling may result in injury.
- **Do not operate the air conditioner when using a room fumigation - type insecticide.**
Failure to observe could cause the chemicals to become deposited in the unit, which could endanger the health of those who are hypersensitive to chemicals.
- **Do not place appliances which produce open fire in places exposed to the air flow from the unit or under the indoor unit.**
It may cause incomplete combustion or deformation of the unit due to the heat.

- **Do not install the air conditioner at any place where flammable gas may leak out.**
If the gas leaks out and stays around the air conditioner, a fire may break out.
- **The appliance is not intended for use by young children or infirm persons without supervision.**
- **Young children should be supervised to ensure that they do not play with the appliance.**

2. PARTS NAMES

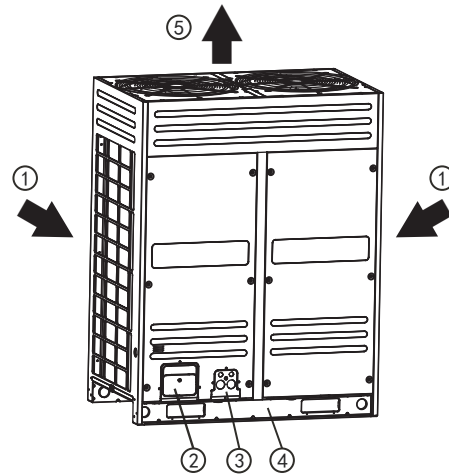

Fig.2-1

Table.2-1

①	Air inlet (Both in Left and right sides, as well as in rear side.)
②	Refrigerant pipe connective opening or wires outlet
③	Refrigerant pipe connective opening or wires outlet
④	Fixed foot
⑤	Air outlet (heat air to be blows out in the cooling operation, vice versa while the heating.)



NOTE

- All the pictures in this manual are for explanation purpose only, There may be slightly different from the air conditioner you purchased (depend on model). The actual shape shall prevail.
- To avoid danger, never put sticks or other objects into it.
- Please preheat the air conditioner for at least 24 hours before operation. Do not switchoff the power if you need to stop the unit for 24h or shorter time. (This is to heat the crank case heater to avoid the compulsive start of compressor.)
- Make sure the air inlet and outlet are not blocked, or it may degrade the performance of air conditioner or start up protector which will stop the unit from running.

3. OPERATION AND PERFORMANCE

■ **Features of heating operation**

- Warm air will not be blown out immediately at the beginning of the heating operation, after 3~5minutes (depends on the indoor and outdoor temperature), until the indoor heat exchanger become hot, then blows out warm air.
- During operation, the fan motor in the outdoor unit may stop running under high temperature.
- During Fan operation, if other indoor Units are running on heating mode, the fan may stop in order to prevent sending heat wind.

■ **Defrost in the heating operation**

- During heating operation, outdoor unit sometimes will frost. To increase efficiency, the unit will start defrosting automatically (about 2~10 minutes), and then water will be drained out from outdoor unit.
- During defrosting, both the fan motors in the outdoor unit and indoor unit will stop running.

■ **Operation conditions**

For proper performance, run the air conditioner under the following temperature conditions:

Table.3-1

Temperature Mode	Outdoor temperature	Indoor temperature	Room relative humidity
Cooling mode	-5°C ~ 48°C	17°C ~ 32°C	below 80%
Heating mode	-20°C ~ 24°C	≤27°C	
Mixed mode	-5°C ~ 24°C	Cooling mode 17°C ~ 32°C Heating mode ≤27°C	



NOTE

Protective device may start if running the unit outside the above condition, which will prevent the unit from operation.

■ **Protection Device**

This protection device will stop the unit automatically in case the air conditioner is on forced running mode. When protection device is activated, running indicator light is lightened and query light flashes. Protection device may start under the following circumstances:

■ **cooling operation:**

- The air inlet or air outlet of outdoor unit is blocked.
- Strong wind is continuously blowing to the air outlet of the outdoor unit.

■ **heating operation:**

- Too much dust and rubbish adhere to the dust filter in the indoor unit

■ **Power cut**

- If power is cut during operation, stop all the operation immediately.
- Power comes again. The operation indicator on the wire controller flashes.
- Push the ON/OFF button again if you want to restart the unit.

■ **Mishandling in operation**

In case of mishandling caused by lighting or mobile wireless, please switch off the manual power off the manual power. Push ON/OFF again when restarting.

■ **Heating capacity**

- The heating process is :absorb heat from outdoor, while expel heat to indoor by hot pump. Once the outdoor temperature drop down, heating capacity is degraded correspondingly.
- It is command to equip with other warming facility, when outdoor temperature is low.
- It is better to equip with additional purchase indoor auxiliary heating device in paramos area where is in particularly low outdoor temperature.(See Indoor Unit Operation Manual for detail information)



NOTE

Please switch off the power when protection device starts. Do not restart until the problems are solved.

4. TROUBLES AND CAUSES



CAUTION

- In case the following malfunctions, please switch off the power and contact the local dealer.Incorrect ON/OFF operation
- Fuse or leakage protector is frequently broken.
- Foreign matter or water falls in the unit.

Please read the following illustration(before apply for servicing)

Table.4-1

	Troubles	Causes
Not malfunction	Outdoor unit <ul style="list-style-type: none"> • White mist or water • The sound of "hiss" 	<ul style="list-style-type: none"> • FAN function stop automatically to defrost. It is the start and stop sound of the solenoid valve • At the beginning and the end of the running process, sounds like water flow in valve occurs, which will be amplified in 3~15 minutes, this is caused by dehumidifying process of refrigerant current. • Slight hiss is caused by heat exchanger as temperature changes. • Pieces of the wall, carpet, furniture, cloth, cigarette, cosmetics are adhere to the unit. • Switch on the power after the power cut. • Other equipment preheating process stops cooling operation. • The operator sets an opposite mode against the fixed cooling and heating mode. • FAN mode stops to avoid cold air blown out. • The master unit with slave units for different purposes, when abnormal accident happen,the director will illustrate.
	Indoor unit <ul style="list-style-type: none"> • Bad odor • Operation lamp flashes • No priority of Standby on panel is lightened 	
Check it again	<ul style="list-style-type: none"> • Start or stop operation automatically 	<ul style="list-style-type: none"> • Wrong operation on timer.
	<ul style="list-style-type: none"> • No operation 	<ul style="list-style-type: none"> • Whether the power is cut. • Whether manual power switch is turned on. • Whether the fuse is melted. • Whether the protection device works. (operation lamp is lightened) • Whether it is the time set.
	<ul style="list-style-type: none"> • Insufficient cooling • Insufficient heating 	<ul style="list-style-type: none"> • Whether the inlet and outlet of outdoor unit is blocked. • Whether the door and window are open. • Whether the air filter is blocked by dust. • Whether the air deflector is in the right place • Whether fan speed is slight or whether it is in FAN mode. • Whether the temperature is set properly. • Whether setting COOL and HEAT simultaneously. (Indicator light Standby or No Priority on panel is lightened)



NOTE

In case of following malfunctions, please switch off the power and contact the local dealer.

1. Incorrect ON/OFF operation.
2. Fuse or leakage protector is frequently broken.
3. Foreign matter or water falls in the unit.

5. MALFUNCTION

Malfunction display of outdoor display

Table.5-1

No.	Error code	Error or protection type	Note
1	E0	Outdoor unit communication error	Only display in auxiliary unit
2	E1	Phase error	
3	E2	Communication error with indoor unit	20 minutes after first power on or indoor and outdoor communication break off over 2 minutes after first power on 20 minutes
4	E4	Outdoor temp. sensor error	
5	E5	Voltage protection	
6	E7	Discharge sensor error	After running 10 minutes, it appears discharge temp. < 15°C and pressure > 3.5MPa. The appearance sustains 2 minutes. Must restart electricity, otherwise cannot recover.
7	E8	Outdoor unit address error	
8	xE9	Drive type mismatch	
9	xH0	Communication error between DSP and main chip	X represents for a system, 1 is A system, 2 is B system
10	H1	Communication error between 0537 and main chip	X represents for a system, 1 is A system, 2 is B system
11	H2	Qty. of outdoor unit decreases error	Only display in main unit
12	H3	Qty. of outdoor unit increases error	Only display in main unit
13	xH4	3 times of P6 protection in 60 minutes	Must restart electricity, otherwise cannot recover
14	H5	3 times of P2 protection in 60 minutes	Must restart electricity, otherwise cannot recover
15	H6	3 times of P4 protection in 100 minutes	Must restart electricity, otherwise cannot recover
16	H7	Qty. of indoor units mismatch	Indoor unit lost for over 3 minutes; not recoverable until the unit qty. recover
17	H8	High pressure sensor error	Air discharging pressure $P_c \leq 0.3$ MPa
18	H9	3 times of P9 protection in 60 minutes	Must restart electricity, otherwise cannot recover
19	C7	3 times of PL protection in 100 minutes	Must restart electricity, otherwise cannot recover
20	xHd	Auxiliary unit error (X=1,2,3, e.g., 1Hd stands for auxiliary unit 1 error)	X represents for a auxiliary unit
21	P0	Inverter compressor top temp. protection	
22	P1	High pressure protection	
23	P2	Low pressure protection	After 3 times P2 protection in 60 minutes will report H5
24	xP3	Compressor current protection	X represents for a system, 1 is A system, 2 is B system
25	P4	Discharge temp. protection	After 3 times P6 protection in 100 minutes will report H6
26	P5	High condenser temp. protection	
27	x(P6)	Inverter module protection	X represents for a system, 1 is A system, 2 is B system. After 3 times (P6) protection in 60 minutes will report H4. If appearing protection and cannot recover in 10 minutes, it will report xP6.
28	P7	Main inverter current protection	
29	P8	Auxiliary inverter current protection	
30	P9	DC fan protection	After 3 times P9 protection in 60 minutes will report H9
31	PL	Main inverter module temp. protection	
32	xL0	DC compressor module error	X represents for a system, 1 is A system, 2 is B system
33	xL1	DC bus low pressure protection	X represents for a system, 1 is A system, 2 is B system
34	xL2	DC bus high pressure protection	X represents for a system, 1 is A system, 2 is B system
35	xL3	Reserve	X represents for a system, 1 is A system, 2 is B system
36	xL4	MCE error/synchronization/closed loop	X represents for a system, 1 is A system, 2 is B system
37	xL5	Zero speed protection	X represents for a system, 1 is A system, 2 is B system
38	xL6	Reserve	X represents for a system, 1 is A system, 2 is B system
39	xL7	Phase error protection	X represents for a system, 1 is A system, 2 is B system
40	xL8	Protection of the speed change between a moment before and after is > 15Hz	X represents for a system, 1 is A system, 2 is B system
41	xL9	Protection of the speed change between the setting speed and the actual speed > 15Hz	X represents for a system, 1 is A system, 2 is B system

6. CONSTRAINT COOLING AND QUERY

■ Constraint Cooling

Once pressing the constraint cooling button(see the chart on the right), all the indoor unit will be on forced cooling mode and the wind speed is HIGH.

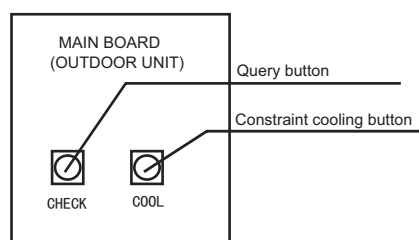

■ SW2 Query Instructions

Fig.6-1

Table.6-1

No.	Normal display	Display content	Note
1	0. --	Outdoor unit address	0,1,2,3
2	1. --	Outdoor unit itself capacity	8,10,12,14,16
3	2. --	Modular outdoor unit qty.	Available for main unit
4	3. --	Operation mode	0,2,3,4,5,6
5	4. --	Total capacity of outdoor unit	Capacity requirement
6	5. --	Cooling capacity	Auxiliary unit only display capacity of main mode
7	6. --	Heating capacity	Auxiliary unit only display capacity of main mode
8	7. --	T4 ambient temp. revision of cooling capacity	
9	8. --	T4 ambient temp. revision of heating capacity	
10	9. --	The outdoor unit actual operation capacity	Capacity requirement
11	10. --	Speed of fan A	0, 1, …, 14,15
12	11. --	Speed of fan B	0, 1, …, 14,15
13	12. --	T2 average temp.	Actual value
14	13. --	T2B average temp.	Actual value
15	14. --	T3 pipe temp. (Left pipe temp.)	Actual value
16	15. --	T5 pipe temp. (Right pipe temp.)	Actual value
17	16. --	T4 ambient temp.	Actual value
18	17. --	Discharge temp.of inverter compressor A	Actual value
19	18. --	Discharge temp.of inverter compressor B	Actual value
20	19. --	Modual temp.	Actual value
21	20. --	Discharge pressure corresponding to the saturation temperature	Actual value+30
22	21. --	The minimum overheating temp. of discharge	Actual value
23	22. --	Current of inverter compressor A	Actual value
24	23. --	Current of inverter compressor B	Actual value
25	24. --	State of the evaporator or condenser	0,1,2,3
26	25. --	Opening angle of EXV A	Actual value+8
27	26. --	Opening angle of EXV B	Actual value+8
28	27. --	High pressure	Actual value×10
29	28. --	Qty. of indoor units	That can communicate with indoor units
30	29. --	Qty. of cooling indoor units	Actual value
31	30. --	Qty. of heating indoor units	Actual value
32	31. --	Reserve	
33	32. --	Night noise control mode	0,1,2,3
34	33. --	Static pressure mode	0,1,2,3
35	34. --	DC voltage A	Actual value+10
36	35. --	DC voltage B	Actual value+10
37	36. --	Reserve	
38	37. --	Reserve	Display code 8.8.8
39	38. --	Remove fault number of times	
40	39. --		Check end

The display contents as followings:

Normal display:

When standby, the high position displays the address of the outdoor unit, and the low position displays the Qty. of indoor units that can communicate with outdoor unit. When it is operating, it will display the rotation frequency of the compressor.

Operation mode:

0-Off; 2-Cooling; 3-Heating; 4-Forcing cooling; 5-Mixed cooling; 6-Mixed Heating.

Fan speed:

0-stop; 1~15 speed increase sequentially, 15 is the max. fan speed. EXV opening angle: Pulse count=Display value×8;

State of the evaporator or condenser:

0-close/condenser; 1-All evaporator; 2-Left evaporator/right condenser; 3-Left evaporator/close

Night noise control mode:

0-Night noise control mode; 1-silent mode; 2-Most silent mode; 3-No priority

Static pressure mode:

0-static pressure is 0 Mpa; 1-Low static pressure; 2-Medium static pressure; 3-High static pressure

7. AFTER-SALES SERVICE

If the air conditioner was operate abnormally, please plug off the power supply firstly, and contact with After-sales Center or Special Distributor. For detail please refer to the attached accessory Consumer Service Instruction.



MUNDO  CLIMA[®]

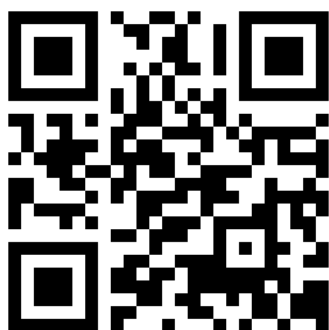

www.mundoclima.com

ASK FOR MORE INFORMATION

Phone: (+34) 93 446 27 80

eMail: info@mundoclima.com

TECHNICAL ASSISTANCE

Phone: (+34) 93 652 53 57