

# MUNDOCLIMA®

## SPLIT CASSETTE



❄️ COOL ONLY:  
**MUCS-24 C**  
**MUCS-41 C**

☀️ ❄️ HEAT PUMP:  
**MUCS-24 H**  
**MUCS-41 H**

# User's manual

# CONTENT

---

Operation procedure	Operation mechanism and working range	1
	Names and functions of parts	2
	Safety cautions	4
	Remote control operation procedure	6
	Optimum operation	15
	Trouble shooting	16
	Installation notes	18
	Care and maintenance	19
	Technical specifications	23
installation	Installation accessories and drawings	24
	Indoor unit installation	26
	Outdoor unit installation	34
	Test and check items after installation	36

- ☉ Thank you purchasing this MUNDOCLIMA air conditioner. Read this MANUAL carefully prior to use of the air conditioner and then keep it properly for future reference.

# Operation mechanism and working range.

## ● Working temperature range.

	Indoor side DB/WB (°C)	Outdoor side DB/WB (°C)
maximum cooling	32/23	43/26
minimum cooling	21/15	21/15
maximum heating	27/-	24/18
minimum heating	20/-	-5/-6

## ● Schematic diagram for cooling only type.

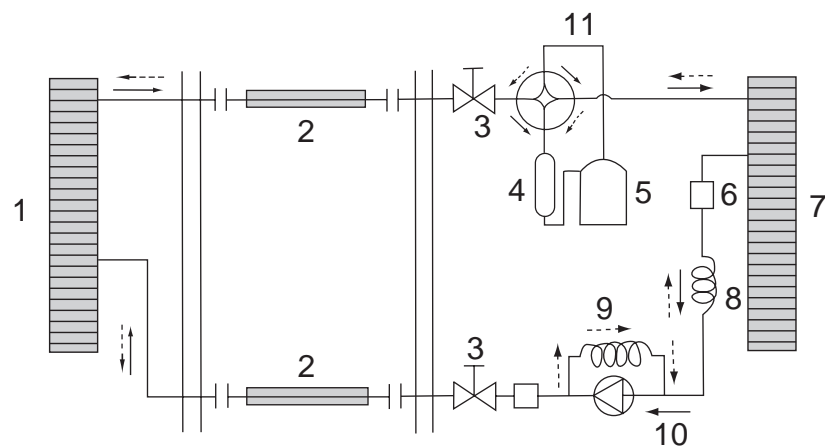
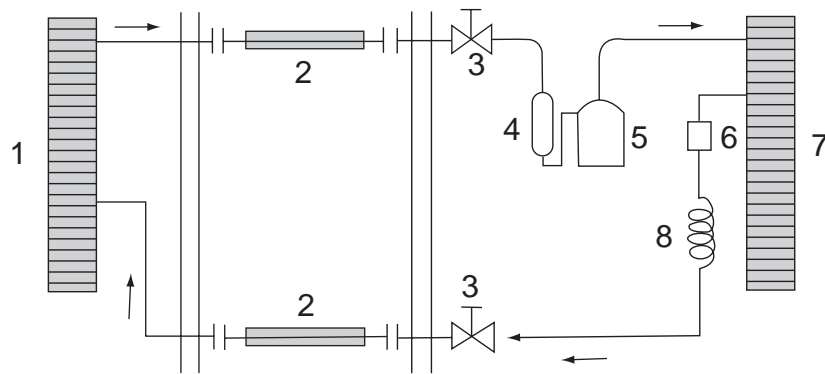

- |                           |                              |                        |
|---------------------------|------------------------------|------------------------|
| 1. Indoor heat-exchanger  | 2. Connecting pipe           | 3. Check valve         |
| 4. Accumulator            | 5. Compressor                | 6. Filter              |
| 7. Outdoor heat-exchanger | 8. Master capillary          | 9. Auxiliary capillary |
| 10. One-way valve         | 11. Four-way reversing valve |                        |

# Names and functions of parts.

## ● Indoor unit

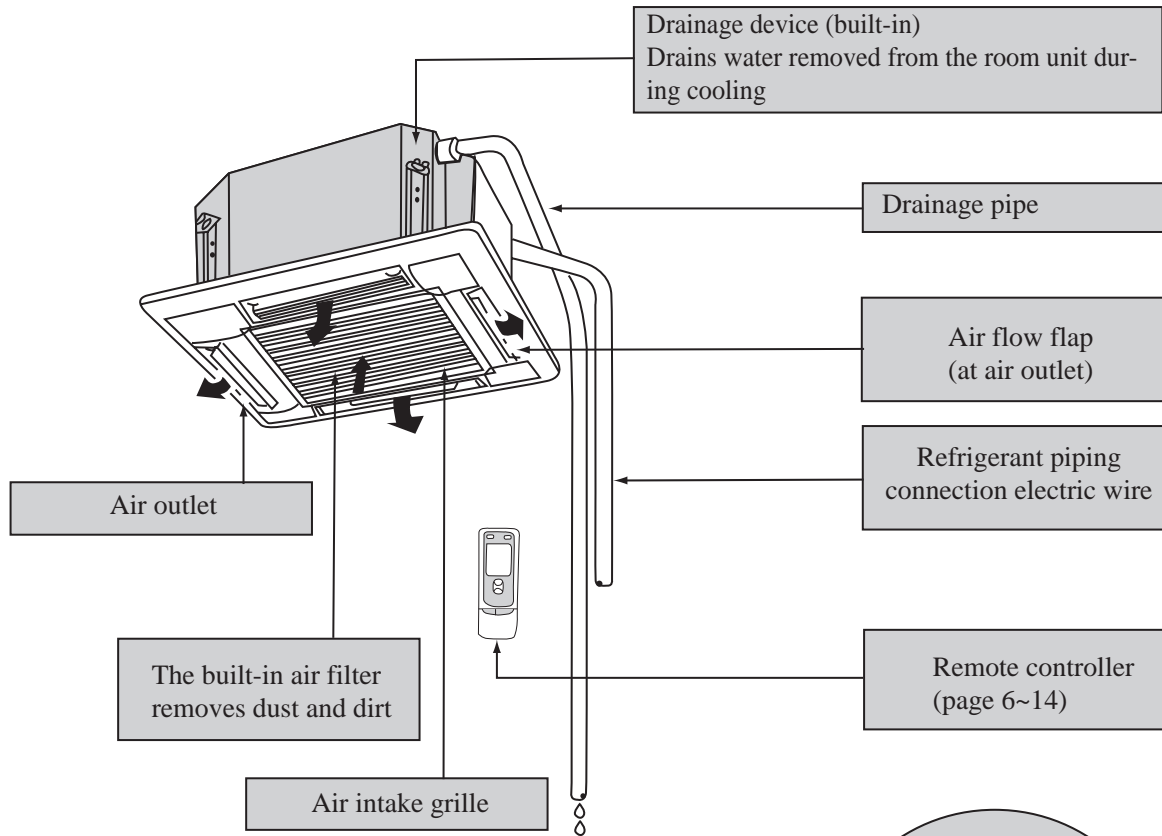

## ● Outdoor unit

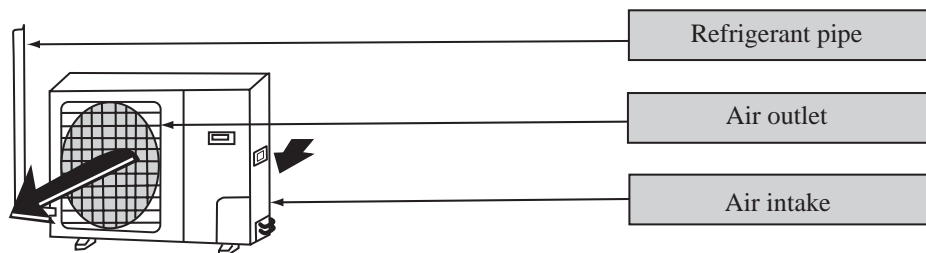

MUCS-24 C  
MUCS-24 H

# Names and functions of parts.

## ● Indoor unit

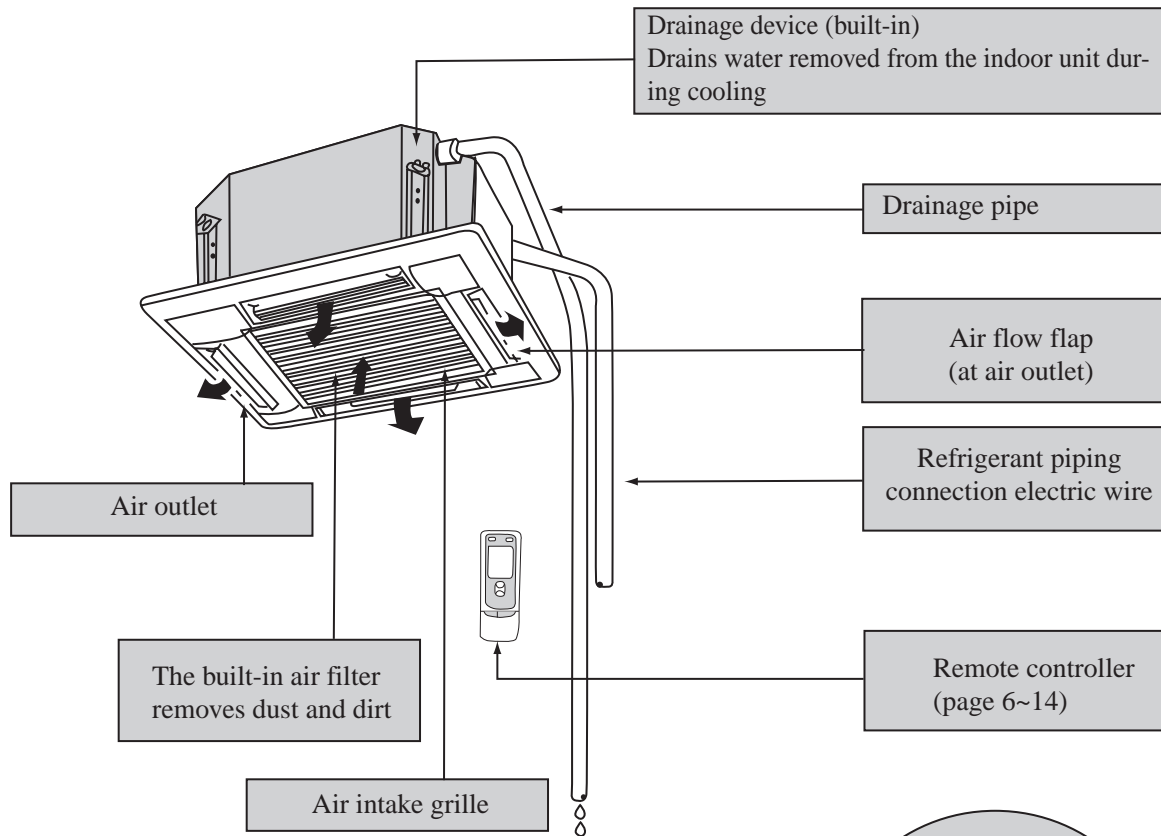

**MUCS-41 C**  
**MUCS-41 H**

## ● Outdoor unit

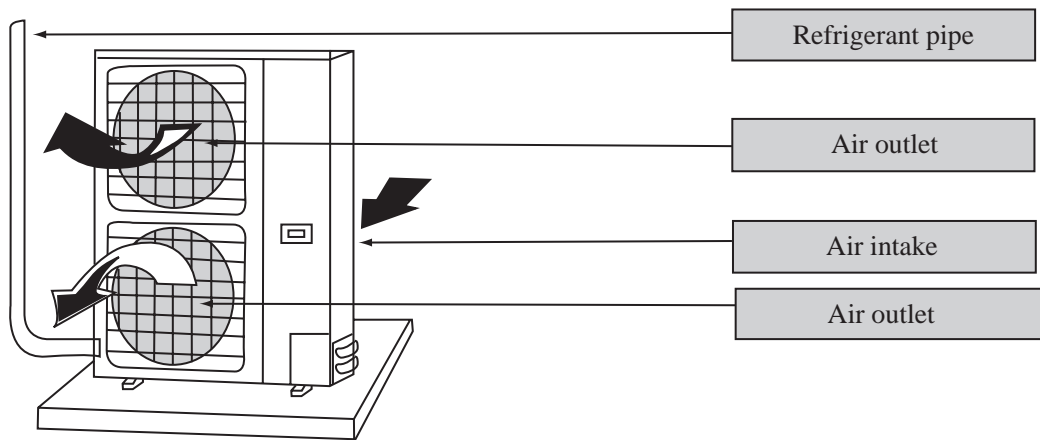

# Safety cautions

● Read the following carefully to assure safe use.

## Warning

Avoid direct air flow to your body and avoid excessive heating or cooling, which may make you feel uncomfortable and do harm to your health.



Check whether the installed stand is still firm enough after the unit has operated for a long time. If a worn-out stand is left unfixed, the unit may topple and do harm.

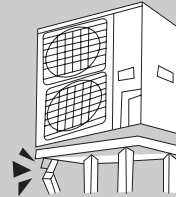

Do not remove protection grill nets from the outdoor unit. Do not reach hands or insert anything into the unit air outlet.

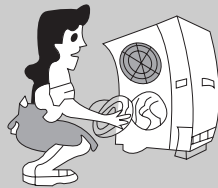

Do not stand on the outdoor unit or put anything on it, or you may fall down or people may get hurt by the falling things.



If there is something abnormal (eg. burning smell), cut off the power immediately and contact service center.



Do not spray any paint or pesticide on the unit, or it may cause fire.

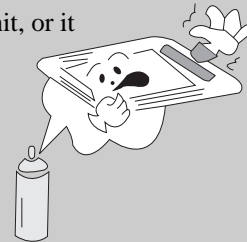

If room air is stuffy, air the room by opening door and window for a while, but please close the curtains when operating the unit to prevent conditioned air from leaking.

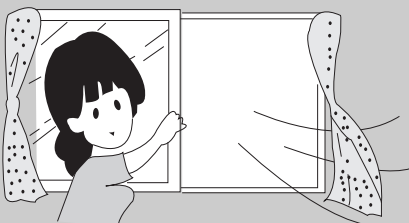

Never use wrong ampere rating wire. Use of iron wire or copper wire may cause the unit to break down or cause fire.

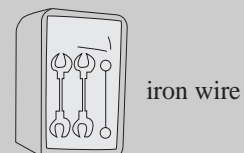

# Safety cautions

## Warning

Do not check or repair during the unit is operating. It is very dangerous.



Do not use other heating equipment near the air conditioner. It will affect the cooling performance.



Never place objects near the air intake and the air outlet of the unit. It may affect performance or stop operation of the unit.

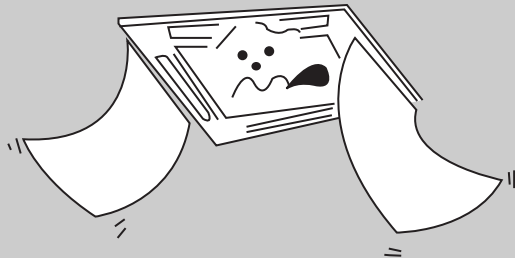

Do not splash water directly to indoor unit. It may cause trouble or electric shock.



Do not bang the remote controller and do not press the button of the remote controller with pointed object, or the remote controller may be damaged.

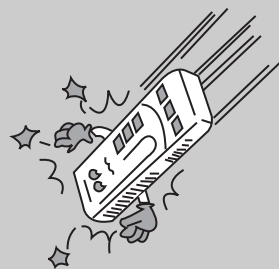

# Remote control operation procedure

## ● Name and Function-Remote control

### Note:

- Be sure that there are no obstructions.
- The remote control signal can be received at a distance of up to about 10m.
- Don't drop or throw the remote control.
- Don't place the remote control in a location exposed to direct sunlight.

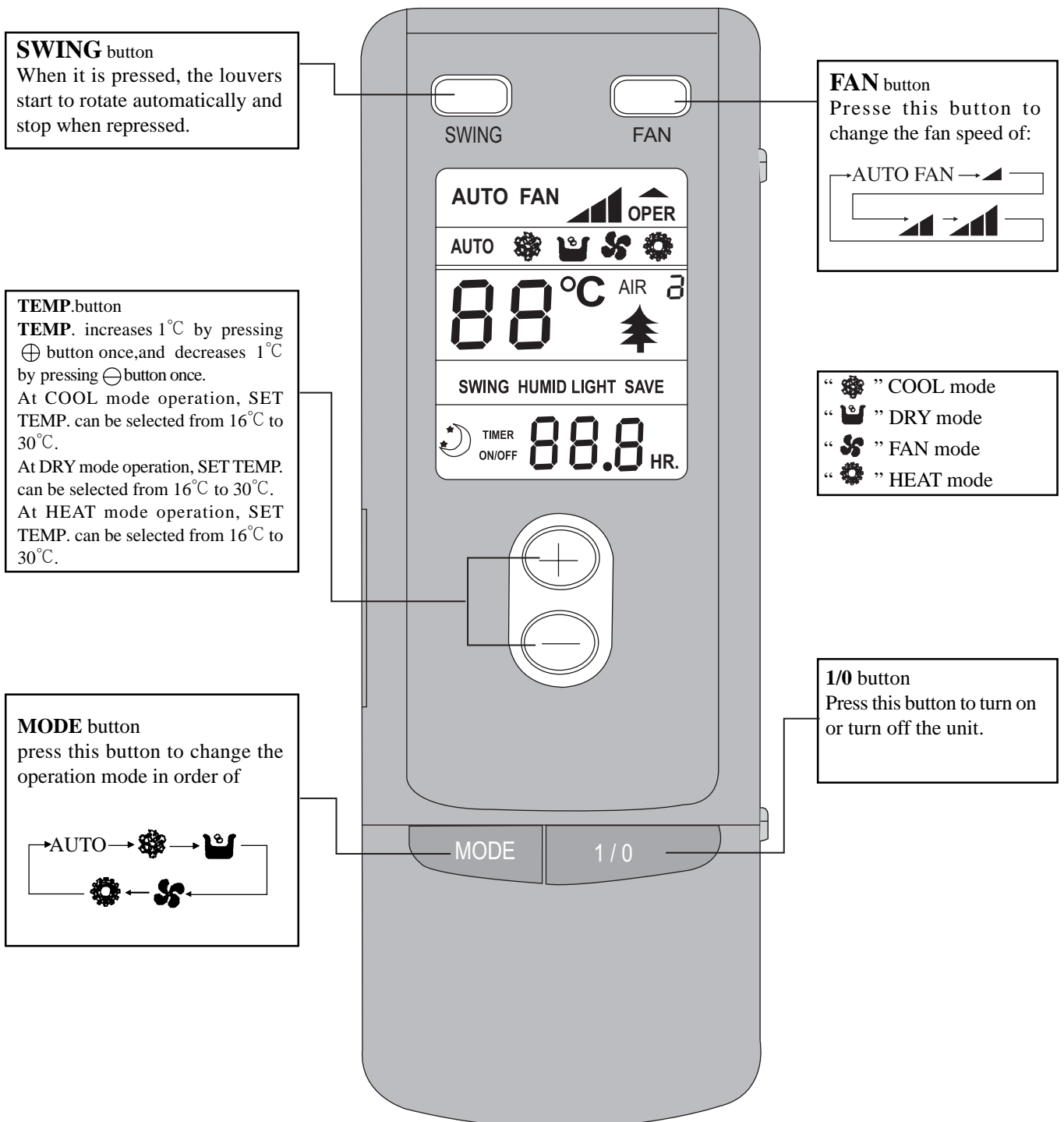



# Remote control operation procedure

## ● Name and Function-Remote control. (Remove the cover)

**Note:** This type of remote controller is a kind of new current controller. Some buttons of the controller which are not available to this Air conditioner will not be described below.

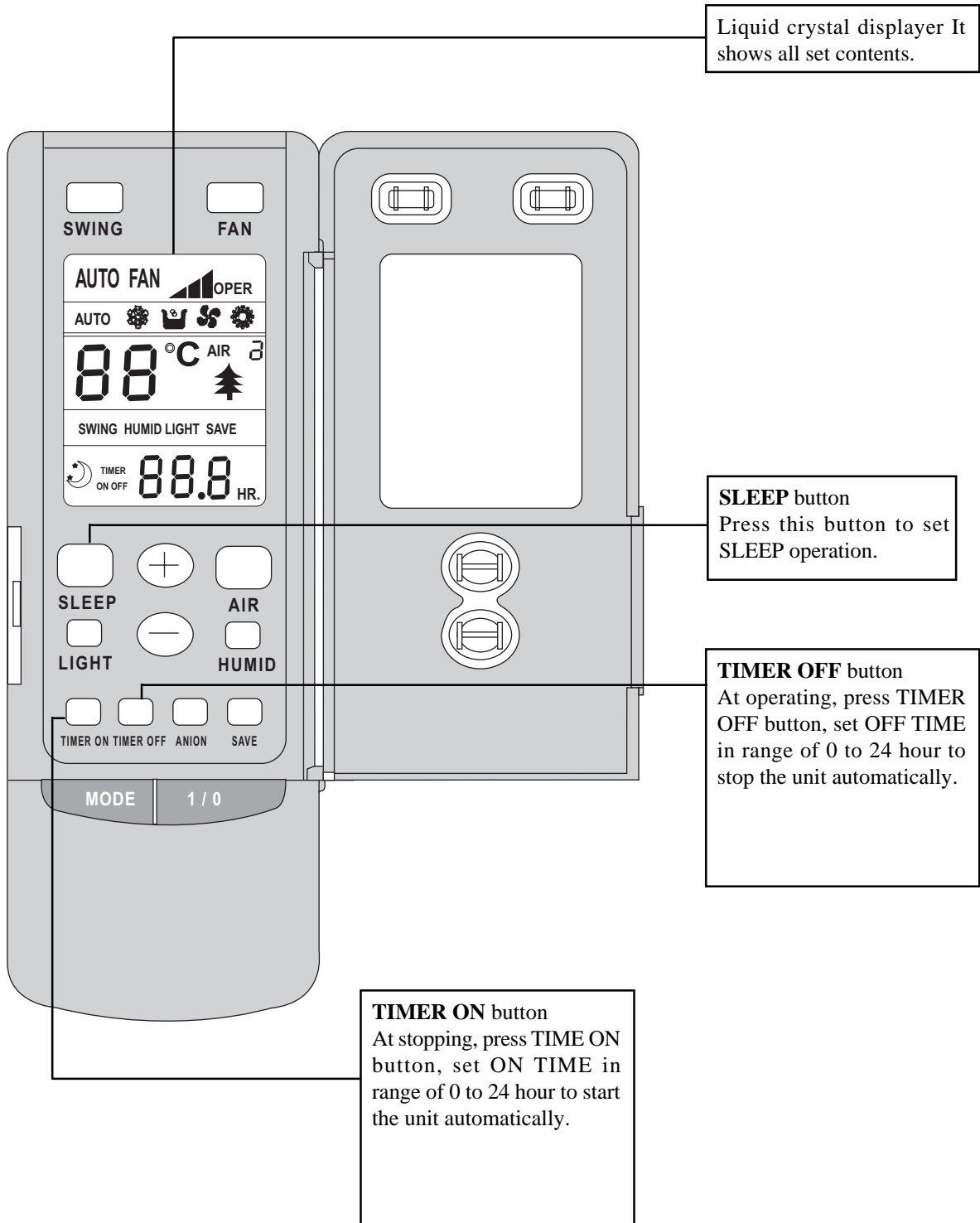

# Remote control operation procedure

## ● COOL mode operation procedure

- According to difference between room temp. and set temp., microcomputer can control cooling on or not.
- If room temp. is higher than set temp., compressor runs at COOL mode.
- If room temp. is lower than set temp., compressor stops and only indoor fan motor runs.
- Set TEMP. should be in range of 16°C to 30°C.

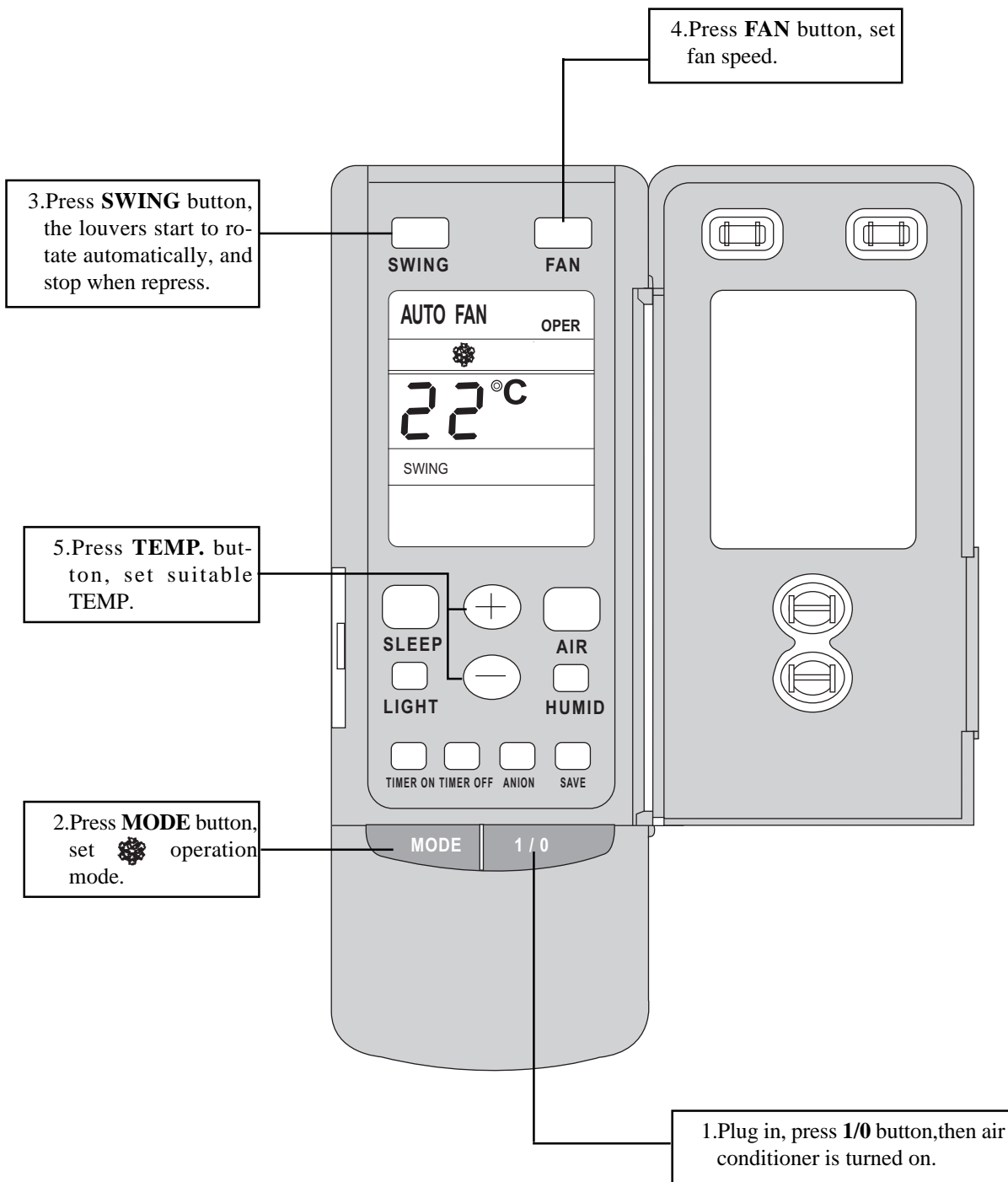

# Remote control operation procedure

## ● HEAT mode operation procedure

- If room temp. is lower than set temp., compressor runs at HEAT mode;
- If room temp. is higher than set temp., compressor and outdoor fan motor stop, only indoor fan motor runs.
- Set TEMP. should be in range of 16°C to 30°C.
- The type of KF-xxx is not this function.

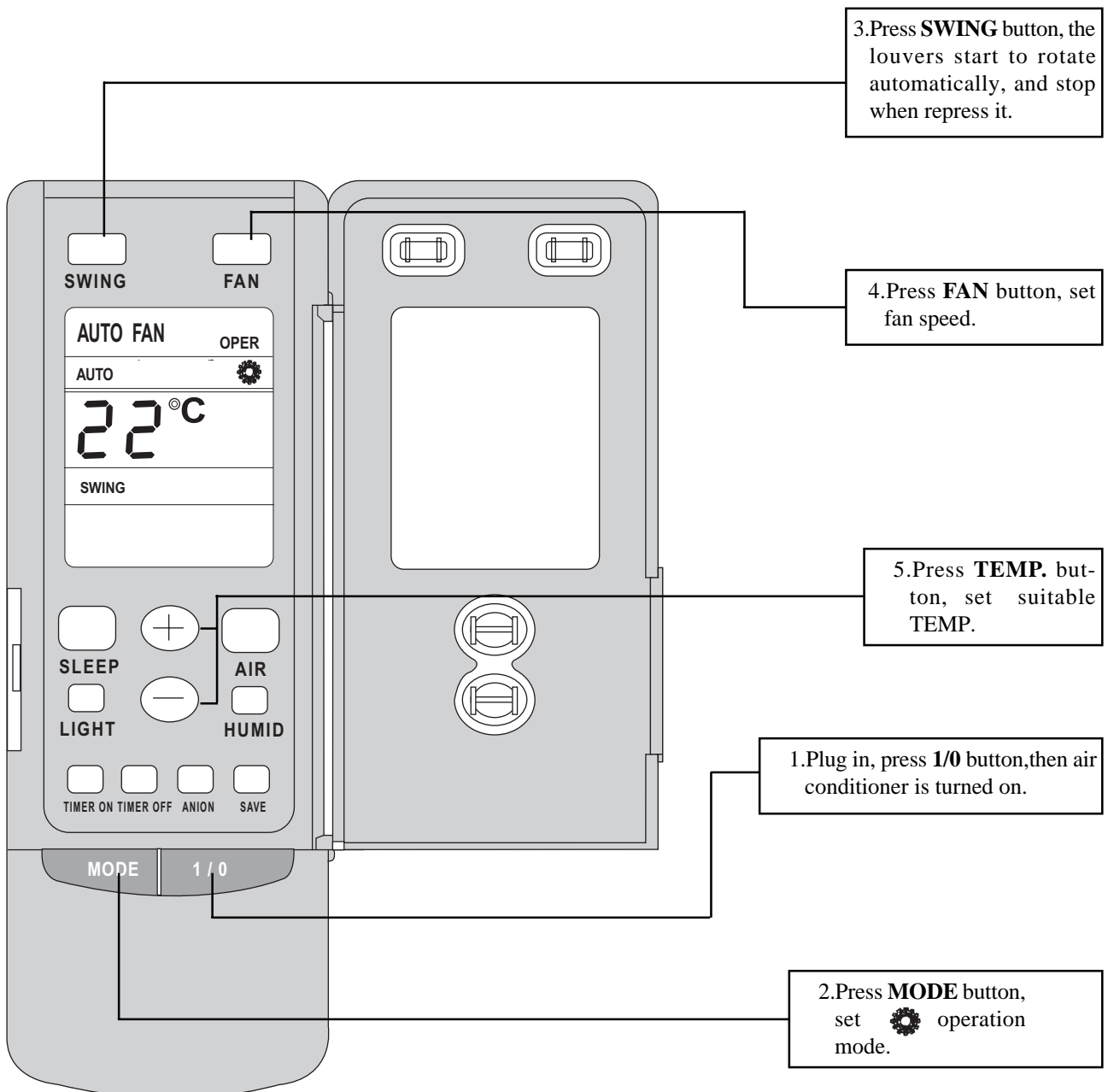

Remote control operation procedure

# Remote control operation procedure

## ● DRY mode operation procedure

- If room temp. is lower than set temp., compressor ,outdoor and indoor fan motor stop. If room temp. is between  $\pm 2^{\circ}\text{C}$  of set temp., Air conditioner is drying.If room temp. is higher than set temp., it's at COOL mode.
- Set TEMP. should be in range of  $16^{\circ}\text{C}$  to  $30^{\circ}\text{C}$ .

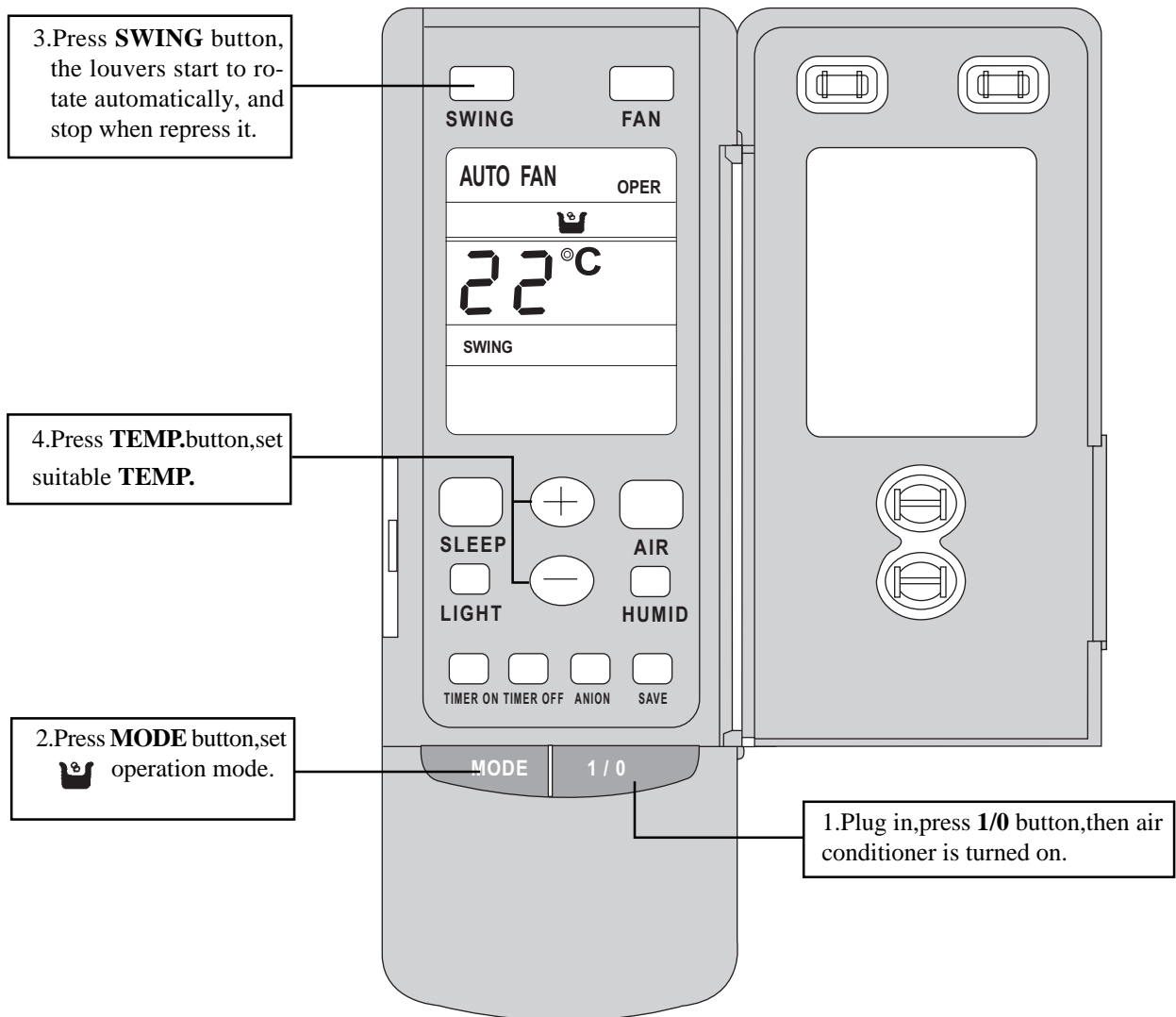

# Remote control operation procedure

## ● AUTO mode operation procedure

- At AUTO mode operation, standard TEMP. is 25°C for COOL mode and 20°C for HEAT mode.

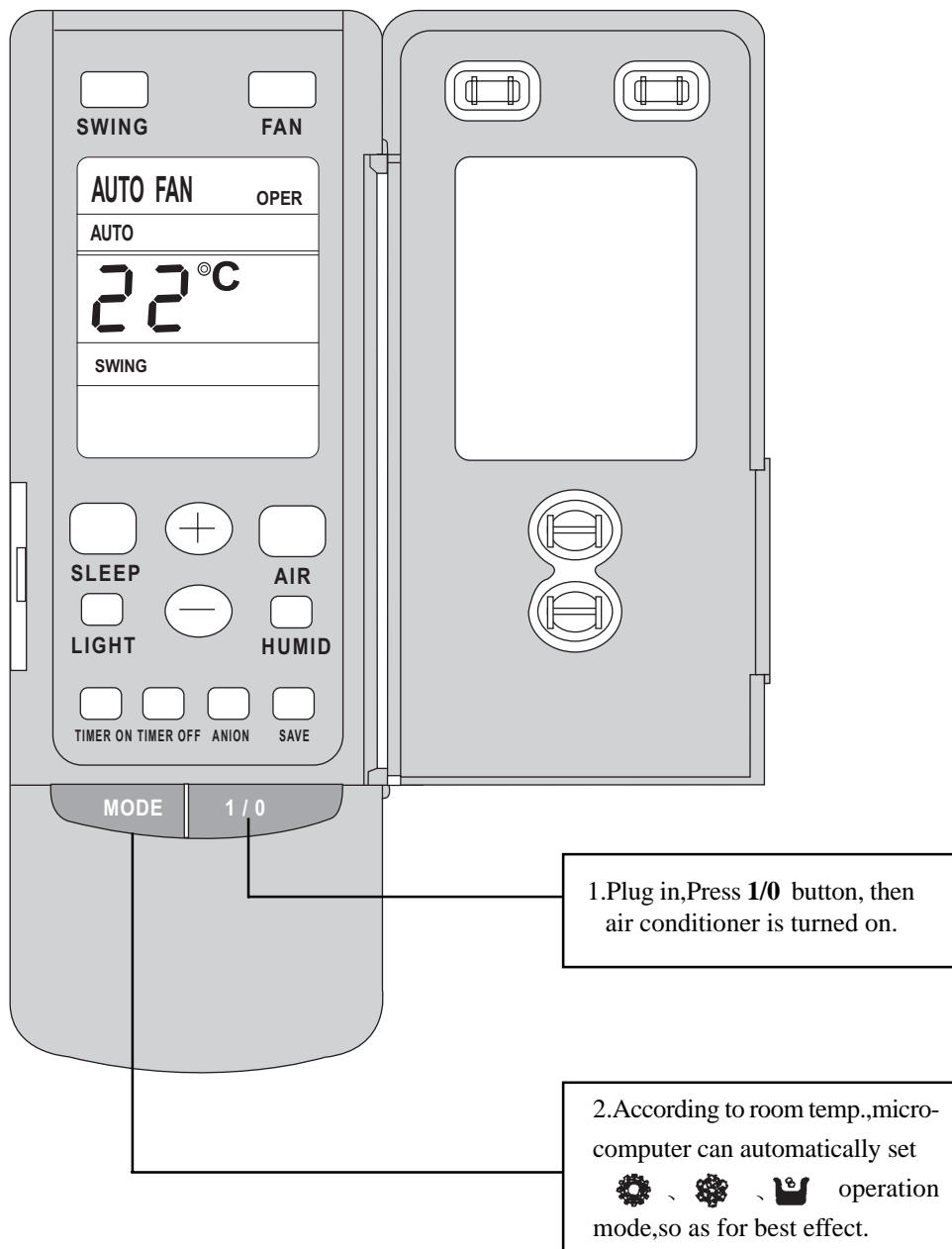

# Remote control operation procedure

## TIMER operation procedure

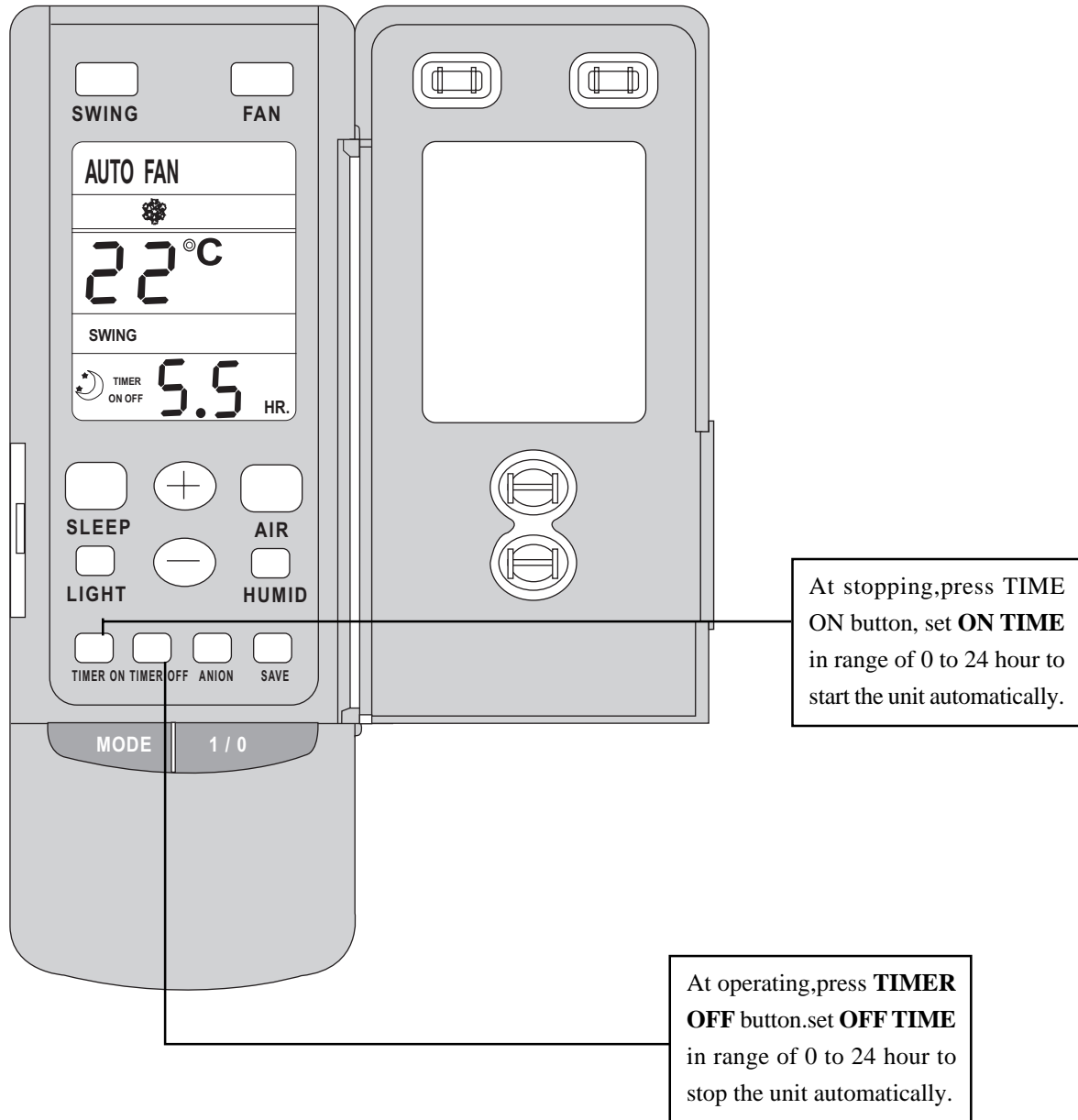

# Remote control operation procedure

## ☾ SLEEP mode operation procedure

- When the unit is cooling or drying, if SLEEP operation is set, TEMP. would increase 1°C in 1 hour and 2°C in 2 hour. Indoor fan motor runs at low speed.
- When the unit is heating, if SLEEP operation is set, TEMP. would decrease 1°C in 1 hour and 2°C in 2 hours. Indoor fan motor runs at low speed.

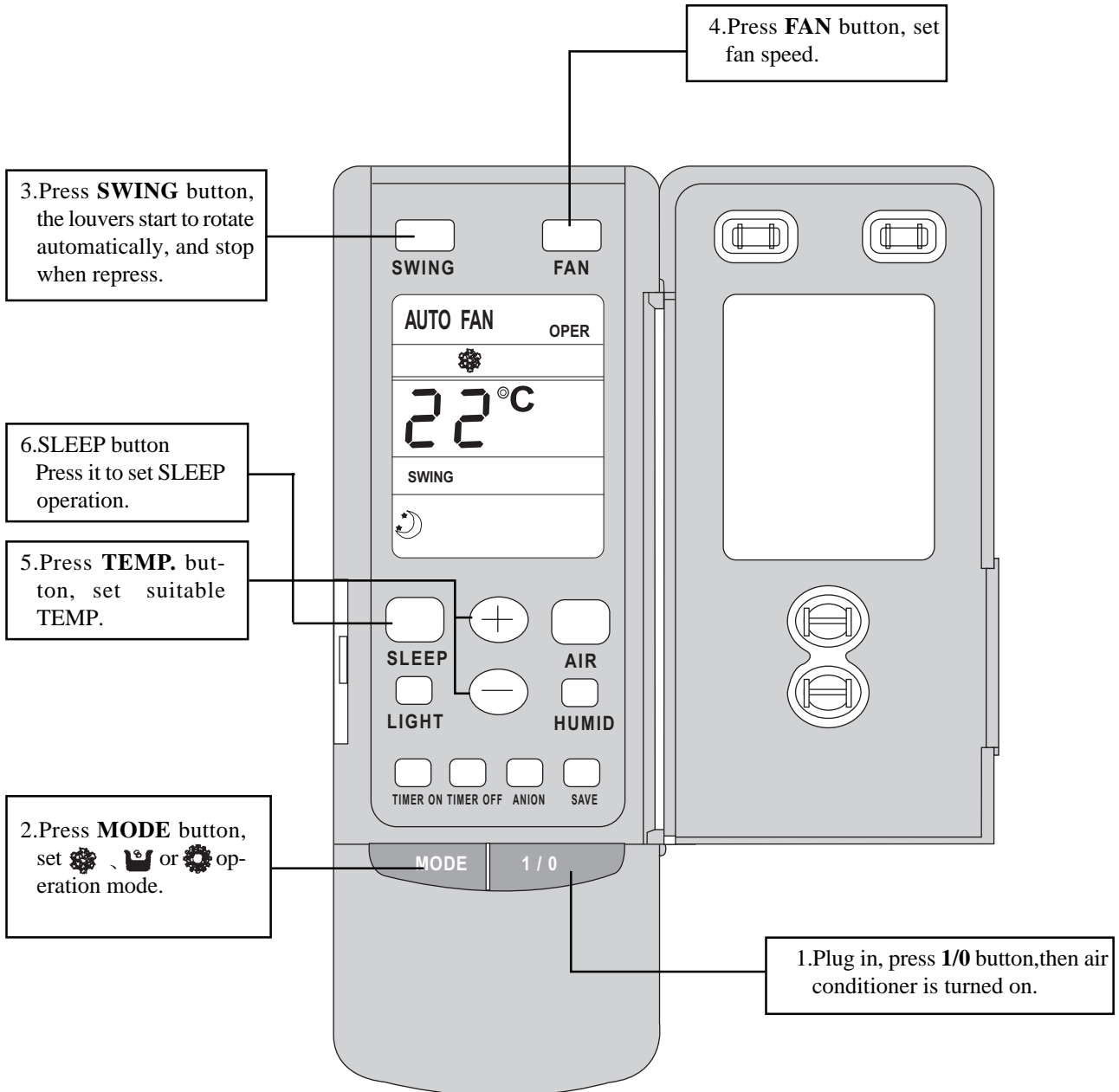

# Remote control operation procedure

## ● How to insert batteries

1. Remove the cover from the back of the remote control.
2. Insert the two batteries ( Two AAA dry - cell batteries ) and press button "ACL".
3. Re - attach the cover.

### Note:

- Don't confuse the new and worn or different batteries.
- Remove batteries when not in use for a longtime.
- The remote control signal can be received at a distance of up to about 10m.

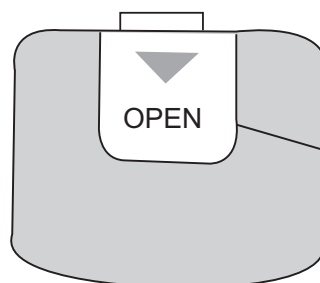
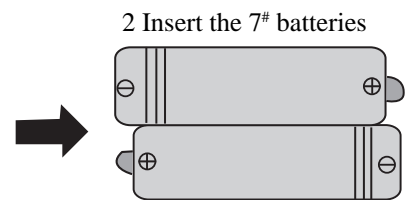
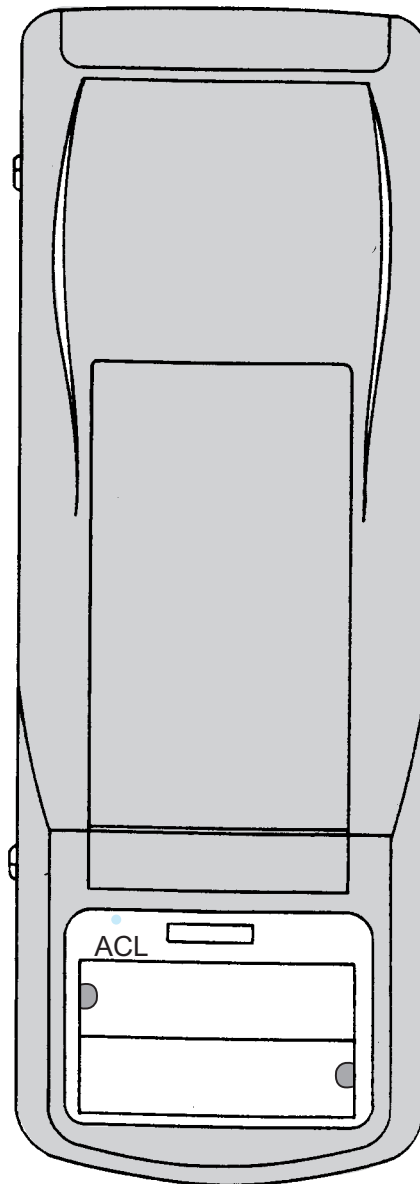

- 1 Remove the cover
- 3 Re - attach the cover.



# Optimum operation

## Adjust the room temperature properly

Adjust the room temperature properly for a comfortable environment.

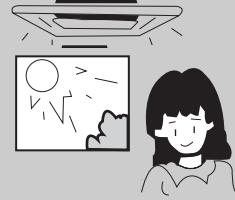

## Never place anything under the indoor unit that is to be kept dry.

Water may drop from the indoor unit when the humidity is over 80% or when the drainage outlet is clogged.

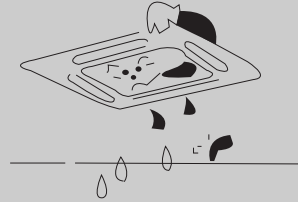

## Turn off the main power supply switch when it is not to be used for long periods of time

When the main power switch is turned on, some watts of electricity is being used even if the system is not operating. Turn off the main power supply switch to save energy.

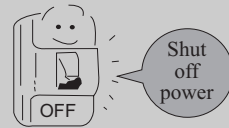

## Do not open the doors and windows for a long time when air conditioner is operating

Cooling and heating performance will be affected if the doors and windows are open for a long time.

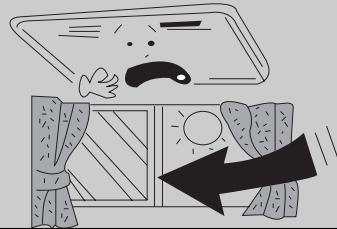

## Place TV, radio, stereo, etc. at least 1m away from the indoor unit and the remote controller.

It may cause interference in the picture or sound.

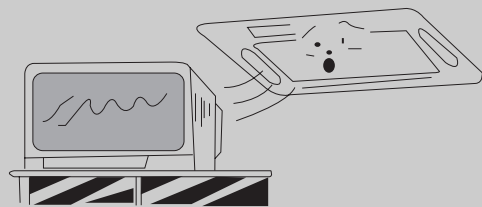

## Avoid direct air flow to pets and plants.

It may do harm to them.

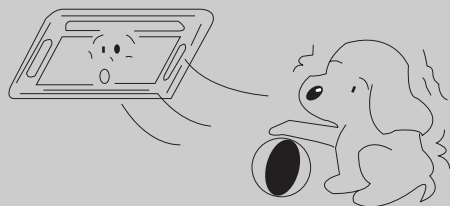

# Trouble shooting

## Warning

- \* In case of something abnormal (such as bad smell), shut off the power switch immediately and contact service center.
- \* Do not repair the air conditioner by yourself because wrong repair may cause fire, please contact service center to do it for you.

## Check item shown below before contacting service center.

Symptom	Cause	Corrective Measures
The system does not operate at all	Pause off or fuse broken	Change fuse or replace fuse
	Power off	It will restart when power is on
	Loose plug	Put the plug into place
	Batteries of remote controller fall	Replace batteries
	Out of the remote controlling range	Keep distance in 8m or less
The system stops right after it is started	Object at the air intake and air outlet of the air conditioner	Remove them
Cooling and heating is malfunctioning	Object at the air intake and air outlet of indoor and outdoor units	Remove them
	Wrong temperature setting	Refer to p6
	Low fan speed	Refer to p6
	Air direction is not correct	Refer to p6
	Doors or windows are open	Close them
	Direct sunshine	Close the curtain or blinder
	Too many people in the room	
	Too many heating sources	
	Dirty air filter	Clean it

## Note:

If trouble still exists after checking the above items, please contact service center.

# Trouble shooting

## ● The following are not troubles

	“ Trouble”	Cause
The unit does not operate when	Restart right after stopping	Once the unit is stopped, it will not operate for about 3 minutes to protect it
	Press SET TEMP.and then release immediately.	
	Power is switched on	Wati for 1 minute
Mist is emitted	When cooling	Room air is chilled rapidly and becomes foggy.
Outdoor unit is hot	after the unit is stopped	Compressor is emitting heat to get ready for restarting.
Noise	Buzz is heard at starting	It’s the starting sound of thermostat and will turn low after 1 minute.
	Sound of running water can be heard during operation	This is caused by the refrigerant flowing inside the unit
	A“ shuh” sound which is heard at the start or immediately after the stop of operation or which is heard at the start or immediately after the stop of defrosting operation.	This is the noise of refrigerant caused by flow stop and flow change. The noise is heard when the drainage pump is in operation.
	A continuous low“ shah” sound is heard when the system is in cooling operation or at a stop.	
	Cracking noise can be heard during or after operation.	This is caused by the panel expanding or contracting due to the change in temperature.
Dust from the units	Starting operation after not using for a long time.	Dust absorbed by the unit blows out
Wind from the outlet smells	During operation	This is caused by the odors in the room which have gotten onto the air conditioner

# Installation notes

Location	Noise
<ul style="list-style-type: none"> <li>• The air conditioner must be firmly installed and 3~4 liability checks must be done every year.</li> <li>• Avoid place within easy reach of young children.</li> <li>• Avoid other heat sources or direct sun light.</li> <li>• Install indoor unit away from TV set or radio.</li> <li>• Avoid where inflammable gas is likely to leak.</li> <li>• At salty coastal areas or special areas such as the vicinity of a sulphurous hot spring, please contact dealer before installation to make sure it is safe to use the unit.</li> <li>• Not to be installed in laundries.</li> </ul>	<ul style="list-style-type: none"> <li>• Select a place with good ventilation or it may affect performance or increase noise.</li> <li>• Install the air conditioner on a foundation that can withstand its weight. Insufficient strength may result in the fall of equipment and cause injury.</li> <li>• Select a place so as not to annoy neighbor with the hot air or noise.</li> <li>• Never place objects near the air outlet or the unit, it may affect performance or increase noise.</li> <li>• If there is abnormal noise during the operating, contact dealer immediately.</li> </ul>
Installation and transportation	Wiring arrangement
<ul style="list-style-type: none"> <li>• Installation and transportation of the unit must be done by skilled personnel.</li> <li>• Be sure to use only the specified accessories and parts for installation, failure to use may lead to electric shock, leakage or fire.</li> <li>• Carry out installation with consideration of strong winds, typhoons, or earthquakes. Improper installation work may result in accidents due to fall of equipment.</li> <li>• If the unit is to be moved to other place, please consult dealer first.</li> </ul>	<ul style="list-style-type: none"> <li>• Make sure wiring is carried out by qualified personnel according to laws and regulations and this manual, using a separate circuit and suitable fuse.</li> <li>• Be sure to install an earth leakage breaker.</li> <li>• Diameter of power supply cord must be big enough. (Refer to P24 about the sizes of diameter)</li> </ul>
<p><b>Earth</b></p> <p>Be sure to connect the earth wire to earth device of the building. Install an earth leakage breaker. Be sure to install enough ampere rating air power switch. (specifications are illustrated in the following table) Do not connect the earth wire to gas or water pipes, lightning conductor or telephone earth wire.</p>	

Model	Air power switch
MUCS-24 C/H	16A
MUCS-41 C/H	20A

## Water pipe

Some parts of the water pipe are made of plastic materials and not suitable for earthing.

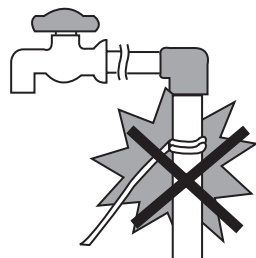

## Gas pipe

If there is electrical leakage accidentally from air conditioner, it is easy to cause fire or explosion.

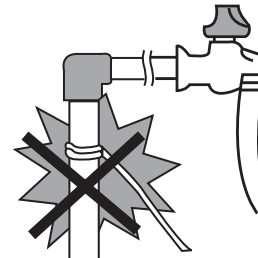

# Care and maintenance

Please pull out the power plug after you used the air conditioner.

## Warning

■ Pull out the power plug before cleaning

■ Do not splash water directly to the unit

### How to clean the air filter

#### 1. Open the suction grille

Use screwdriver screws the two screws.  
Slide both knobs simultaneously as shown and then pull them downward slowly.

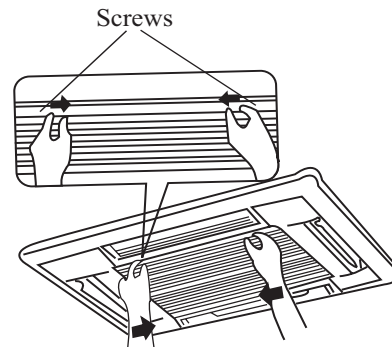

#### 2. Remove the air filters.

Slide knobs on the back of the suction grille outward and remove the air filter.  
Then remove three air cleaners on it.

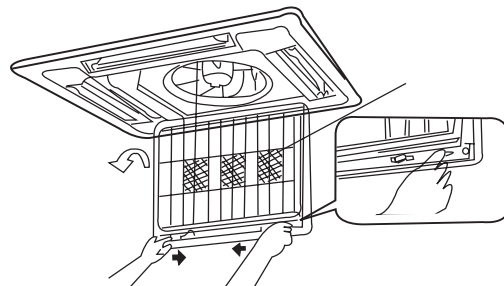

#### 3. Clean the air filter

Use vacuum or wash the air filter with water when the air filter is very dirty, use neutral detergent and water. Let the filter dry naturally at shady place.

#### Note:

- Do not clean with hot water
- Do not dry over fire
- Do not run the air conditioner without the air filter.

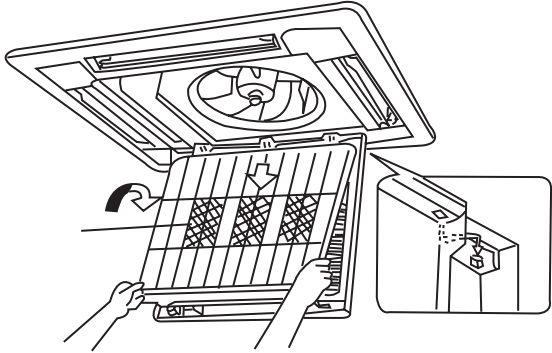

# Care and maintenance

<p>4. Fix the air filters</p> <ul style="list-style-type: none"> <li>• Fix three air cleaner on the air filter and then fix the air filter to the suction grille by hanging it to the projected portion above suction grille.</li> <li>• Set air filter by sliding the knob on the back of the suction grille inward.</li> </ul>	
<p>Shut the suction grille.</p>	<p>Refer to step 1.</p>

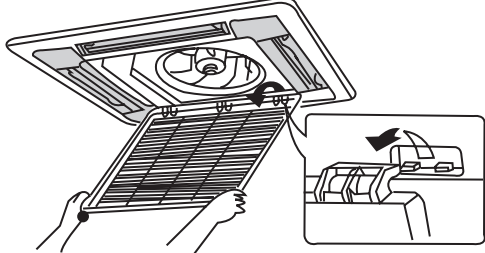
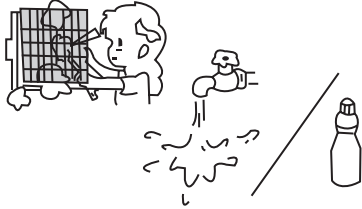
How to clean the suction grille	
<p>1. Open the suction grille.</p>	<p>See step 1 of “ How to clean the air filter”</p>
<p>2. Remove the air filters.</p>	<p>See step 2 of “ How to clean the air filter”</p>
<p>3. Remove the suction grille Open the suction grille at 45° and then lift.</p>	
<p>4. Wash with water. When the suction grille is very dirty, use soft brush and neutral detergent. Shake off water and dry in a shady place. Notes: Do not wash with hot water.</p>	
<p>5. Fix the suction grille</p>	<p>Refer to step 3.</p>
<p>6. Fix the air filter.</p>	<p>See step 4 of “ How to clean the air filter”</p>
<p>7. Close the suction grille</p>	<p>Refer to step 1.</p>

# Care and maintenance

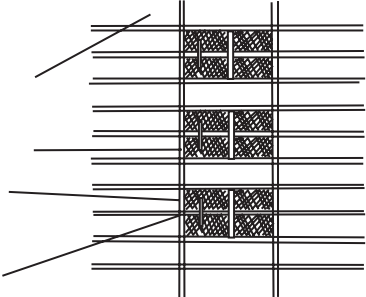
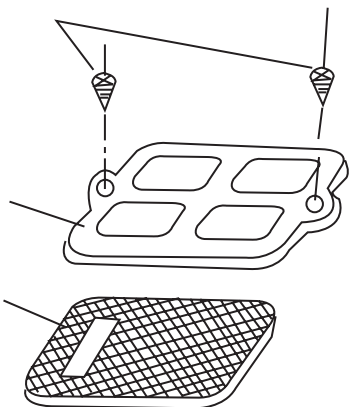
Changing air cleaner	
1. Open the suction grille	See step 1 of “ How to clean the air filter”
2. Remove the air cleaner Remove the air filter, and remove the air cleaner after unscrewing.	
3. Take off packing bag and put in new static electricity fiber filter, then fix them on the air filter.	
4. Fix the air filter	See step 4 of “ How to clean the air filter”

## Air cleaner functions and service cycle time

- Absorbs bad smell in air such as carbon monoxide, carbon dioxide, benzol, gasoline and so on.
- Absorbs harmful objects bigger than 1.0 um in air such as dust, flower powder, germ, virus and so on.
- It can be used for about half a year to one year.

# Care and maintenance

How to clean the air outlet and case.

- Clean with soft cloth or use water and neutral detergent.
- Do not use gasoline, benzene, thinner, polishing powder, liquid insecticide, which may cause discoloring or warping. If the air flow flap is very dirty, you may remove it to clean as shown below.

## Detach and fix the flap

### 1. Detach the flap

Loosen the screws on the sides of the flap.  
clean with soft cloth.

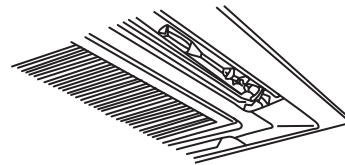

### 2. Fix the flap

Set the ribs on the sides of the air outlet to the slit of the flap and then screw together to fix the flap.

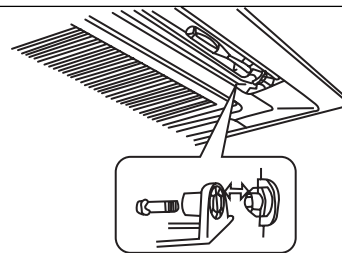

## Before starting the air conditioner for the first time in the season

1. Check to make sure no objects obstructing the intake and outlets parts on both the indoor and outdoor units.
2. Check to make sure ground wire is connected and that it is not damaged.
3. Check to make sure air filter has been cleaned.
4. Turn on the power 6 hours before starting the air conditioner.



## End of season cleaning

1. Clean the filter and the body of the unit.
2. Turn off power.
3. Clear outdoor unit of dust.
4. If there is any rust in the outdoor unit, this should be painted over to prevent the rust from spreading.

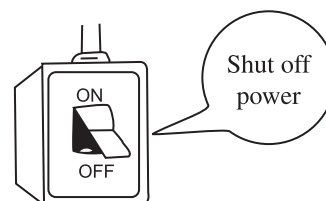



## Technical specifications



























	MUCS-24 C	MUCS-41 C	MUCS- 24 H	MUCS-41 H
	R407C			
Cooling capacity	W	12000	7000	12000
	BTU/h	41000	24000	41000
	Kcal/h	10350	6000	10350
Heating capacity	W	-	7000	12000
	BTU/h	-	24000	41000
	Kcal/h	-	6000	10350
Cooling rated power	W	3800	4900	3800
	W	-	4100	4800
Drying capacity	L/h	3.9	6.8	6.8
	m <sup>3</sup> /h	1180	1860	1860
Volt-Phase-Frecuence	V-Hz-Ph	230-50-1	400-50-3	230-50-1
	Noise level indoor unit	47	54	47
Noise level outdoor unit	dB(A)	59	62	59
	mm	950	950	950
Height indoor unit	mm	950	950	950
	mm	240	240	240
Width outdoor unit	mm	950	950	950
	mm	840	1250	840
Depth indoor unit	mm	412	412	412
	mm	30/75	38/112	30/75
Gas pipe diameter	inch	5/8"	3/4"	5/8"
	inch	3/8"	1/2"	3/8"
Cooling line max. length	m	20	20	20
	m	15	15	15

\* Datas listed above may be changed without informing the consumers;

\* Please see the nameplate for actual datas.

# Installation accessories and drawings

## Accessories

	Name	Shape	Quantity		Notes
1	Drainage hose		1		
2	Clamp		1		
3	Washer		10	10	
4	Clamp		4	L=200	
5	Paper pad for installation		1		
6	Screws		4	ST4.8 × 13-F	
7	Washer fixing plate		4		
8	Insulation for gas pipe		1		
9	Insulation for liquid pipe		1		
10	Big sealing pad		1	5 × 160 × 300	
11	Sealing pad		1	5 × 45 × 300	
12	Small sealing pad		2	3 × 30 × 150	
13	outdoor unit drainage head		1		
14	Sealing bar		1	120 × 65 × 25	
15	PVC tape		2	30 × 10	
16	Remote controller		1		
17	Battery		2	7号 1.5V	
18	Plastic sleeve		1		
19	Signal control wire		1	H07RN-F 5 × 1	MUCS-24 H MUCS-41 C
				H07RN-F 4 × 1	MUCS-24 C MUCS-41 C MUCS-41 H
				H07RN-F 4 × 1	MUCS-41 H
20	Signal control wire		1	H05RN-F 3 × 0.75	MUCS-24 C MUCS-24 H MUCS-41 H
				H05RN-F 2 × 0.75	MUCS-24 C
21	Power supply wire		1	H07RN-F 5 G 1.5	MUCS-41 H MUCS-41 C
				H05VV-F 3 G 1.0	MUCS-41 H
				H07RN-F 3 G 2.5	MUCS-24 H MUCS-24 C
22	Power connecting wire		1	H05RN-F 3 G 0.75	MUCS-24 C MUCS-24 H MUCS-41 H
23	Corrugated pipe		4		
24	Air cleaner hold		3		
25	Air cleaner		3		
26	Screws		8	ST4.2 × 9.5PA	
27	Stem		2		

# Installation accessories and drawings

## Installation drawings

### Indoor unit

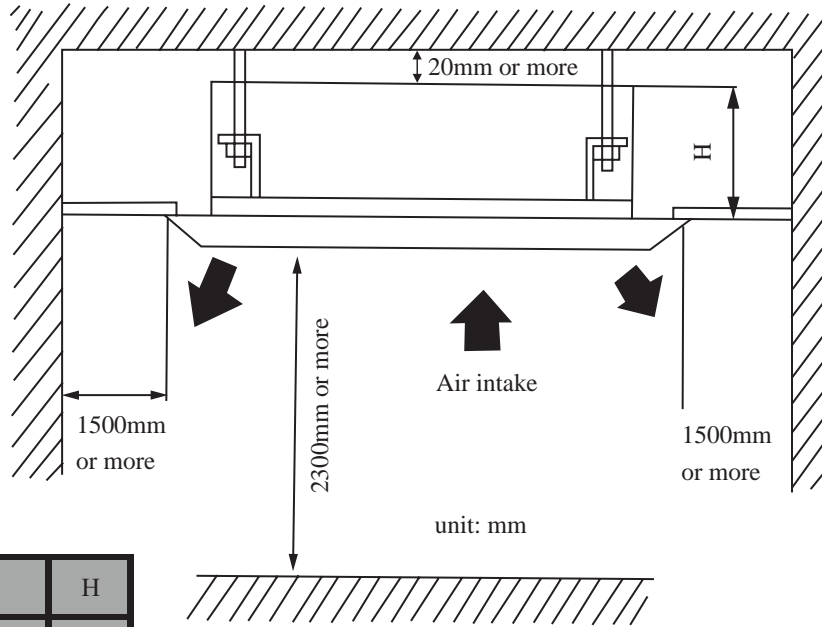

Model	H
MUCS-24C/MUCS-24H	260
MUCS-41C/MUCS-41H	340

Ground

(Fig.1)

### Outdoor unit

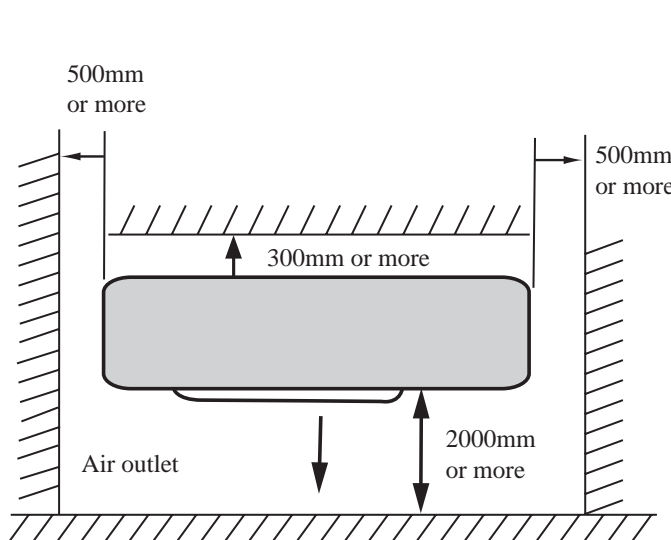

Ground

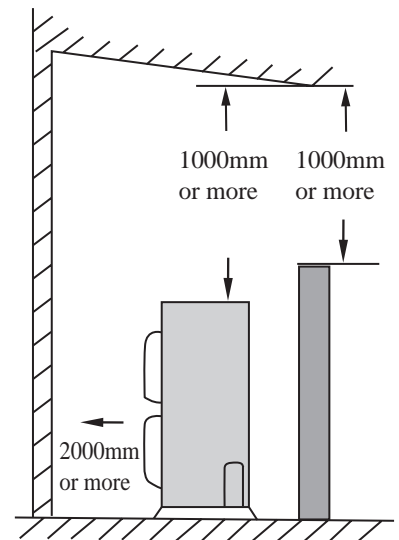

(Fig.2)

### Note:

Air conditioner must be installed by skilled personnel according to this manual.

# Indoor unit installation

## ● Location

1. Do not place object near the air outlet so that conditioned air can reach the whole room.
2. Be sure to install the indoor unit firmly and horizontally.
3. Select the place that can support 4 times of the indoor unit's weight and will not increase noise and vibration.
4. Select a place easy to drain water and connect with the outdoor unit.
5. Make sure there is enough space for maintenance and make sure the distance between the unit and ground is 2.3m or more.
6. Make sure the suspension bolt pitch can hold 4 times of the indoor units' weight, otherwise, you should strengthen the suspension bolt pitch.

## ● Note:

1. Keep enough distance from the kitchen.
2. The appliance shall not be installed in the laundry.

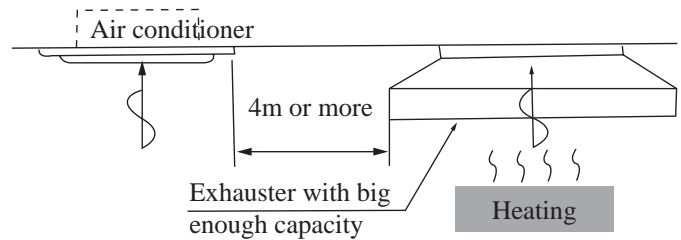

## ● Ceiling opening and suspension bolt (M10) pitch dimension.

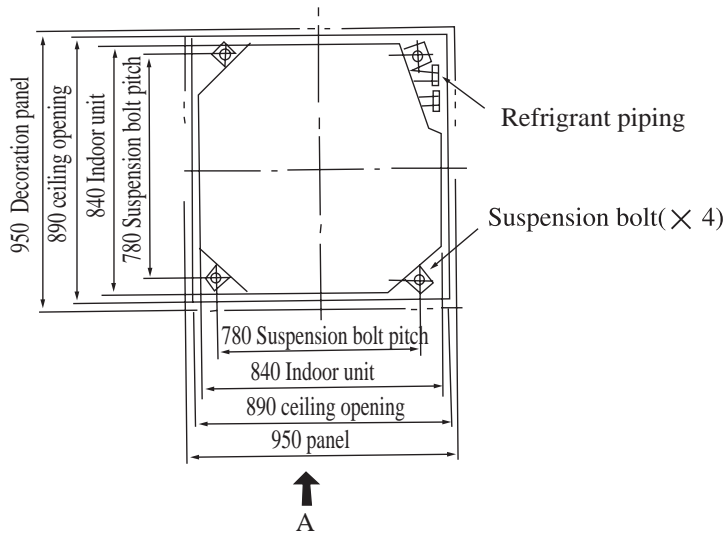

\* Drilling of ceiling must be done by qualified personnel.

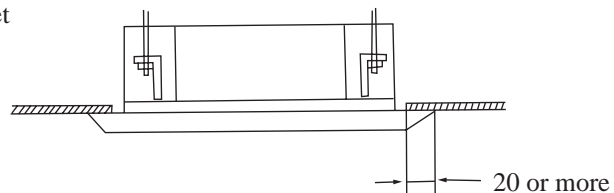
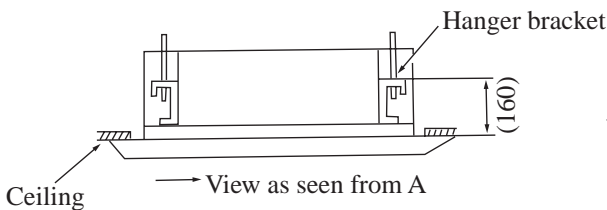

## ● Note

Installation is possible with a ceiling dimension of 890 (marked with \* can be 910), but the ceiling-panel overlapping dimension must be 20mm or more.

# Indoor unit installation

## Indoor unit installation

1. Install the indoor unit temporarily.

- Attach the hanger bracket to the suspension bolt. Be sure to fix it securely by using a nut and washer from the upper and lower sides of the hanger bracket. The washer fixing plate ⑦ will prevent the washer from falling.
- Refer to the paper pad for installation ⑤ for ceiling opening dimension.
- The center of the ceiling is indicated on the paper pad for installation, the center of the unit is indicated on the label attached to the unit and on the paper pad for installation.
- Fix the paper pad to the unit with screws ⑥ (× 3)

3. Refer to diagram 3, adjust the unit to the right position for installation.

4. Check if the unit is horizontally level.

- The indoor unit is equipped with a built-in drainage pump and float switch. At each of the unit's 4 corners, verify that it is level by using a water level or a water filled vinyl tube. (If the unit is tilted against condensate flow, the float switch may malfunction and cause water to drip.)

5. Remove the washer fixing plate ⑦ used for preventing the washer from falling and tighten the upper nut.

6. Remove the paper pad for installation ⑤.

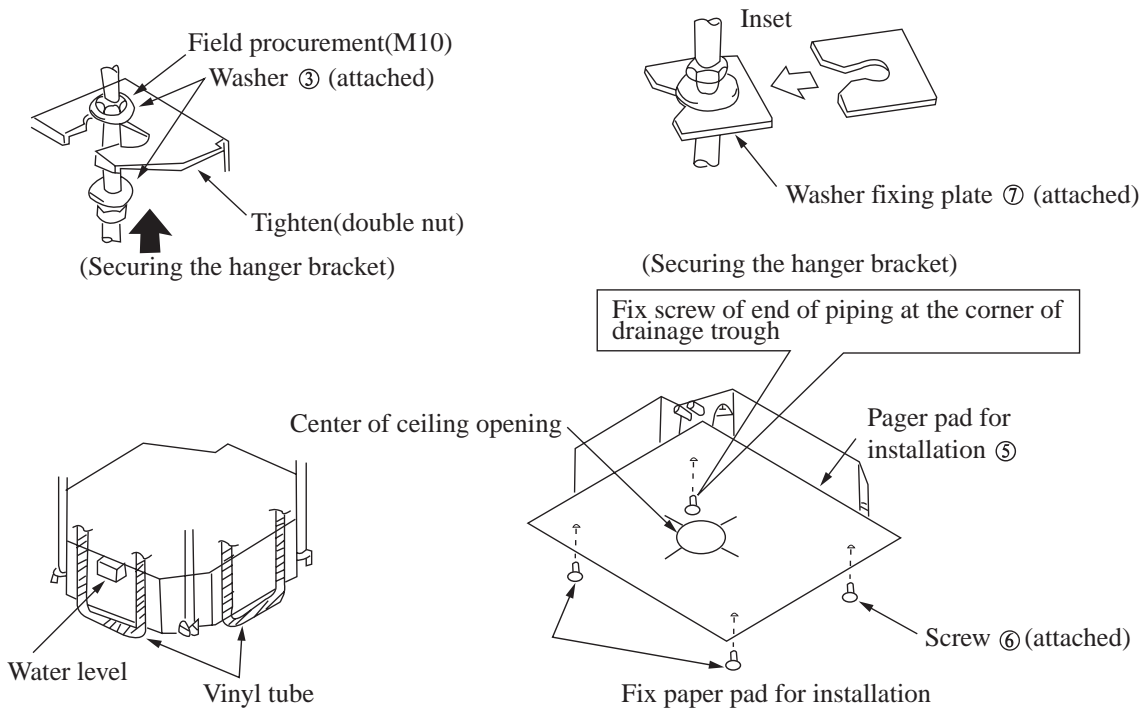

### Warning

Tighten the nut to prevent the unit from falling.

# Indoor unit installation

## ● Connection of refrigerant pipe

- Be sure to use both a spanner and torque wrench together as shown in the drawing, connecting or disconnecting pipes to/from the unit.
- Refer to table 1 to determine the proper tightening torque (over tightening may damage the flare and cause leaks.)
- When connecting the flare nut, coat the flare both inside and outside with refrigerating machine oil and initially tighten by hand 3 or 4 turns.
- Check the pipe connector for gas leaks, then insulate it as shown in the drawing below.
- Use sealing pad (11) to wrap joint between gas pipe and the insulation (8).

Coat here with refrigerating machine oil

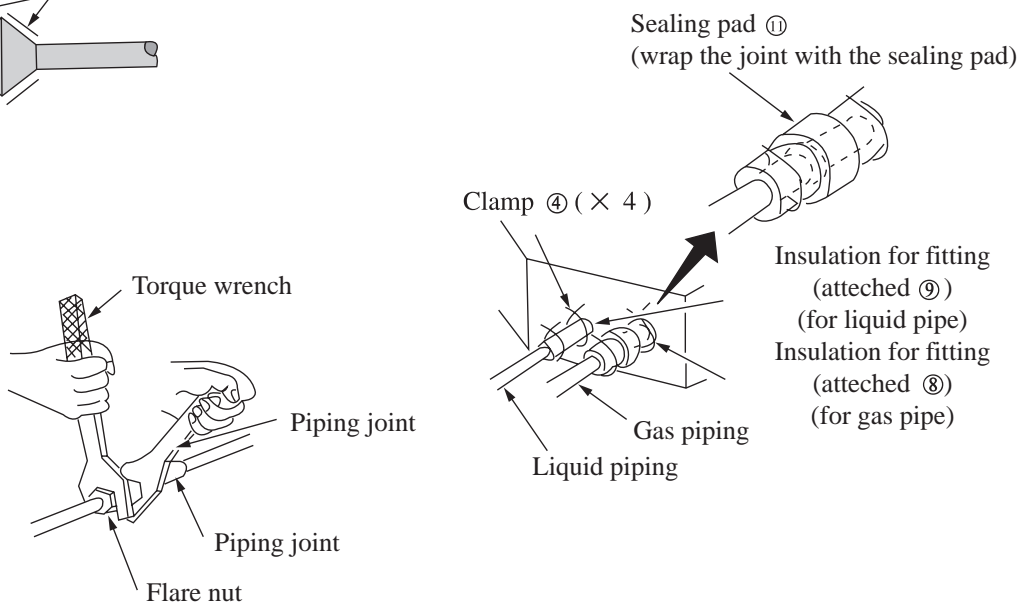
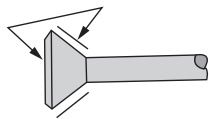

● Table 1

Pipe gauge	Tightening torque
3/8"	30 to 40 N.m
1/2"	45 to 50 N.m
5/8"	60 to 65 N.m
3/4"	70 to 75 N.m

The maximum length for refrigerant piping is 25 meters (but KF(R)-50TW/E1N is 15 meters), when the length exceeds 10 meters, you should charge additional (refrigerant as shown in following for per-meter added).

# Indoor unit installation

## ● Drainage pipe

1. Installation of drainage pipe.

- The diameter of the drainage pipe should be greater than or equal to the diameter of the connecting pipe [vinyl tube, pipe size: 25mm (outer dimension)]
- Keep the drainage pipe short and sloping downwards at a gradient of at least 1/100 to prevent air pockets from forming.
- If the drainage hose cannot be sufficiently set on a slope, add a drainage raising pipe.
- To keep the drainage hose from sagging, keep space between hanging hooks at 1~1.5m.

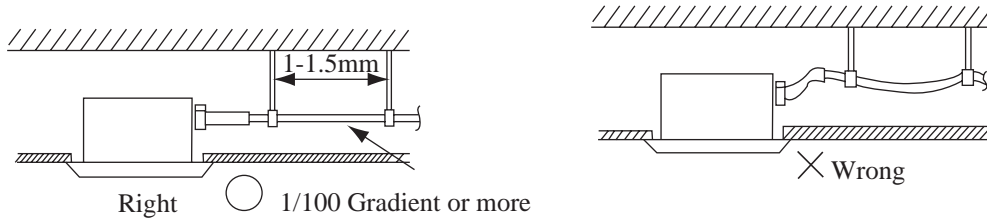

- Use the attached drainage hose ① and clamp ②. Insert the drainage hose into the drainage socket up to the grey tape. Tighten the clamp until the screw head is less than 4 mm from the hose.
- Wrap the big sealing pad around clamp of the drainage hose to insulate.
- Insulate the drainage hose inside the room.

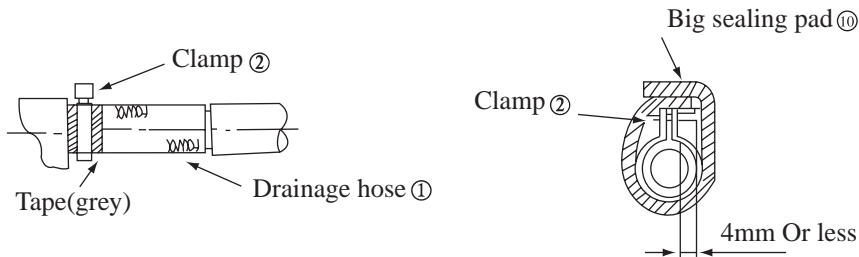

## ● Precautions for drainage raising pipe

- Install the drainage raising pipe at a height of less than 280 mm.
- Install the drainage raising pipe at a right angle to the indoor unit and no more than 300 mm from the unit.

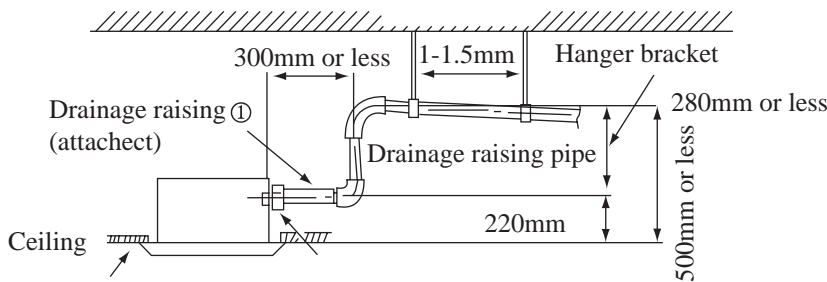

## ● Note

- The incline of attached drain hose ① should be 75mm or less, so that the drainage socket does not have to stand additional force.
- If converging multiple drainage pipes, install according to the procedure shown below.

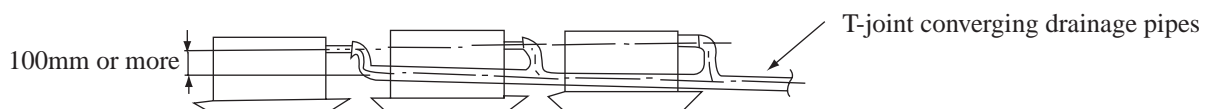
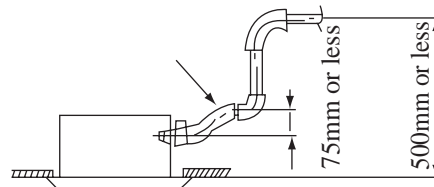

Select converging drainage pipes whose gauge is suitable for the operating capacity of the unit.

# Indoor unit installation

2. After finishing installation, check if drainage water flows smoothly.

- Add approximately 600 cc of water to the drainage trough through air outlet or inspection hole slowly and check drainage flow.
- When electric wiring is finished, check drainage flow during cooling operation.

## ● Method of adding water.

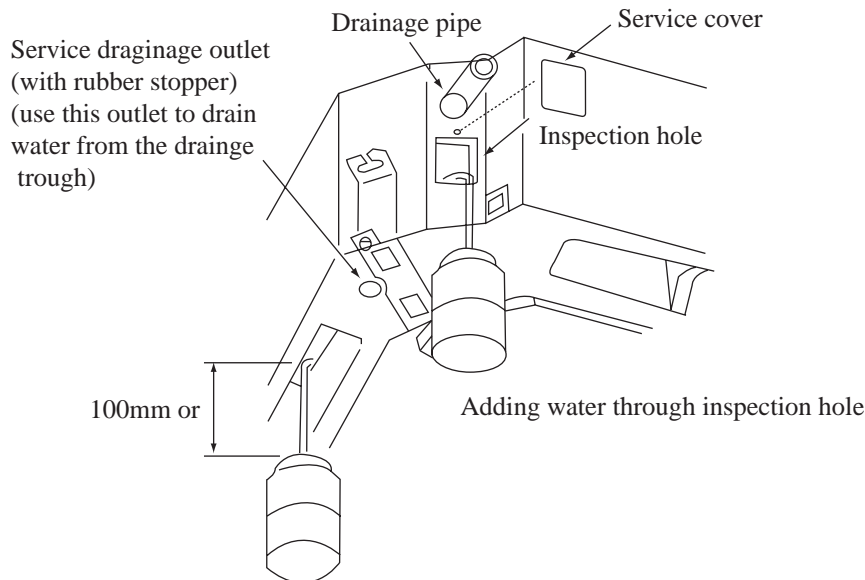

## ● Warning: Before obtaining access to terminals, all supply circuits must be disconnected.

## ● Electric wiring

- All field supplied parts and materials must conform to local laws and regulations.
- For electric wiring, refer to “ WIRING DIAGRAM ” attached to the unit body.
- All wiring must be performed by a skilled technician.
- A circuit breaker capable of shutting down power supply to the entire system and which have at least 3 mm contact separation in each jole must be install in the fixed wiring.
- Earth properly.
- Wiring must conform to national laws and regulations.
- The fixed wiring must be installed with a protector with not more that 30 mA leakage current.
- If the supply cord is damaged, it must be replaced by the manufactory or its service agents or a similarty qualified person in order to avoid a hazard.

## ● Wiring of unit and the controller

- Wiring of the indoor unit.
- Remove the control box lid(1), pull the wires inside through rubber bush I and wiring according to the “ WIRING DIAGRAM ”, then tighten it with clamp.
- Wiring of the controller
- Remove the control box lid(2), pull wires inside through rubber bush II and connect to the controller.
- Wrap the wire with sealing pad(12).
- After wiring, tighten it with clamp and fix the control box lid(1),(2).
- Heating and cooling: connect the rubber wire (5-cords) to the power supply terminal board in properly.
- Cooling: connect the rubber wire (3-cords) to the power supply terminal board properly.



# Indoor unit installation

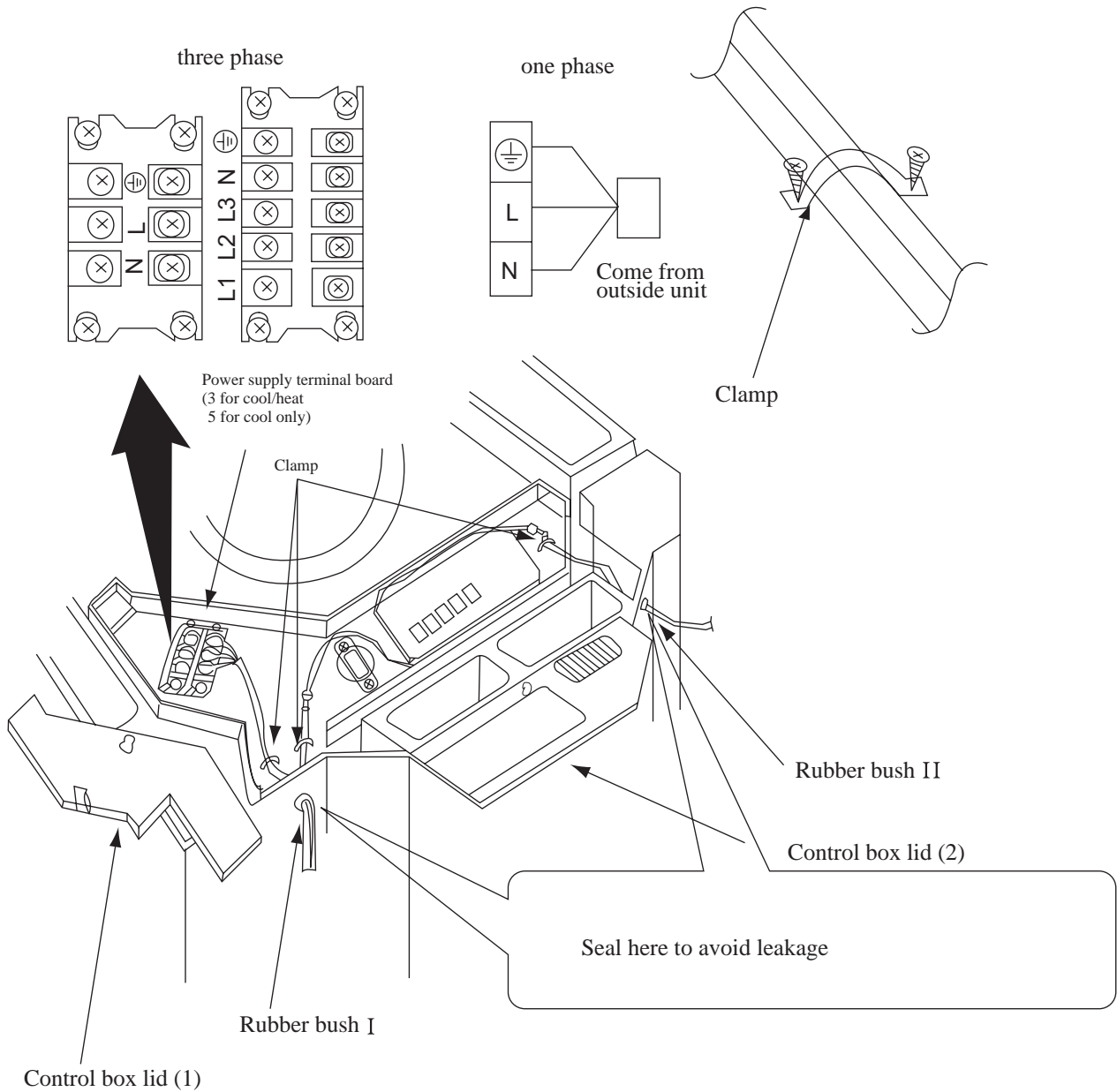

## ● Precautions: Be sure to connect the indoor unit and outdoor unit at right poles.

### Installation of panel

1. Set the panel to the indoor unit body by matching the position of the swing flap motor of the decoration panel to the piping position of the panel to the piping position of the indoor unit as shown in fig.4.
2. Install the decoration panel
  - (1) Hang the latch, which is located on the opposite side of the swing flap motor on the panel, temporarily to the book of the indoor unit. (2 Positions)
  - (2) Temporarily hang the remaining 2 latches to the hooks on the sides of the indoor unit. (be careful not to let the swing motor lead wire get caught in the sealing material.)
  - (3) Screw all 4 hexagon head screws located right beneath the latches in approximately 15mm. (panel will rise)
  - (4) Adjust the panel by turning it to the arrowed direction in Fig.4 so that the ceiling opening is completely covered.
  - (5) Tighten the screws until the thickness of the sealing material between the panel and the indoor unit body is reduced to 5~8 mm.

# Indoor unit installation

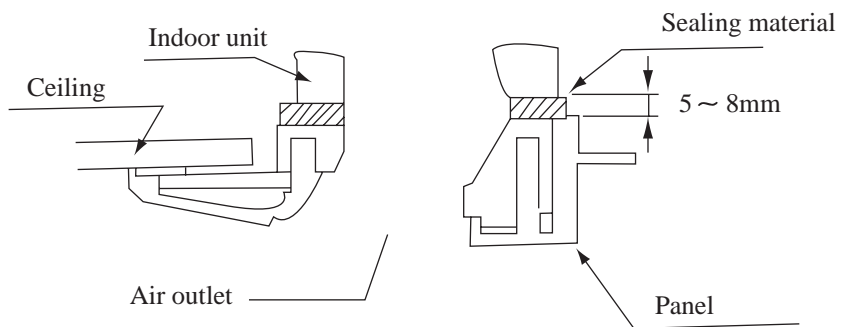
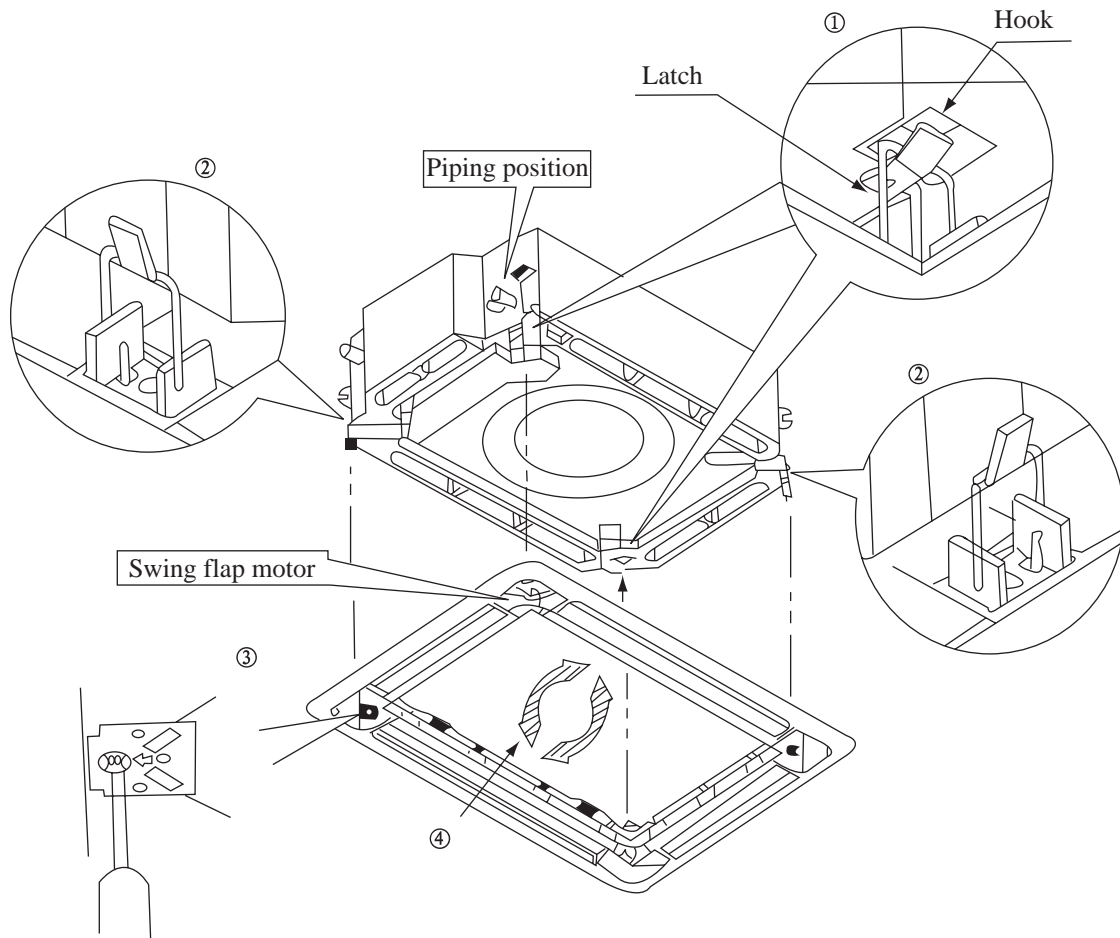

(Fig.4)

## ● Precautions

1. Improper screwing of the screws may cause the troubles shown in Fig.5

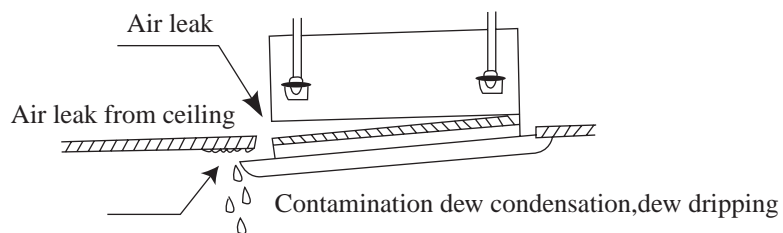

(Fig.5)

# Indoor unit installation

2. If gap is still left between the ceiling and the panel after screwing the screws, readjust height of the indoor unit body (Refer to Fig.6)

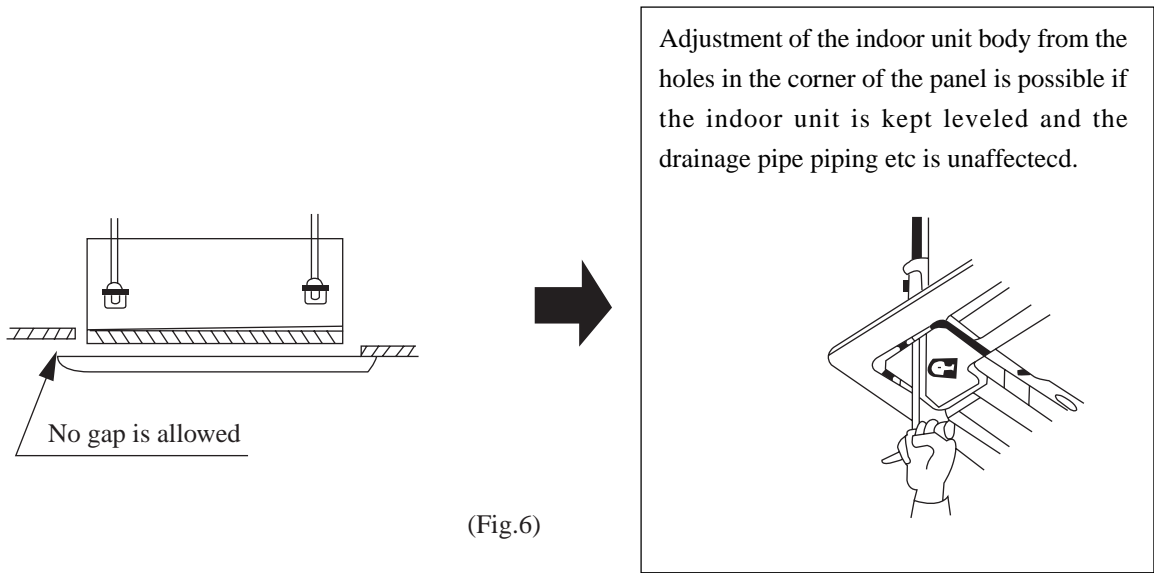

\* After fixing, be sure no gap left between the ceiling and the panel

3. Wiring of the decoration panel.

- ⑥ Connect te joints for swing flap motor lead wire (at 2 places) installed on the panel (Refer to Fig.7)

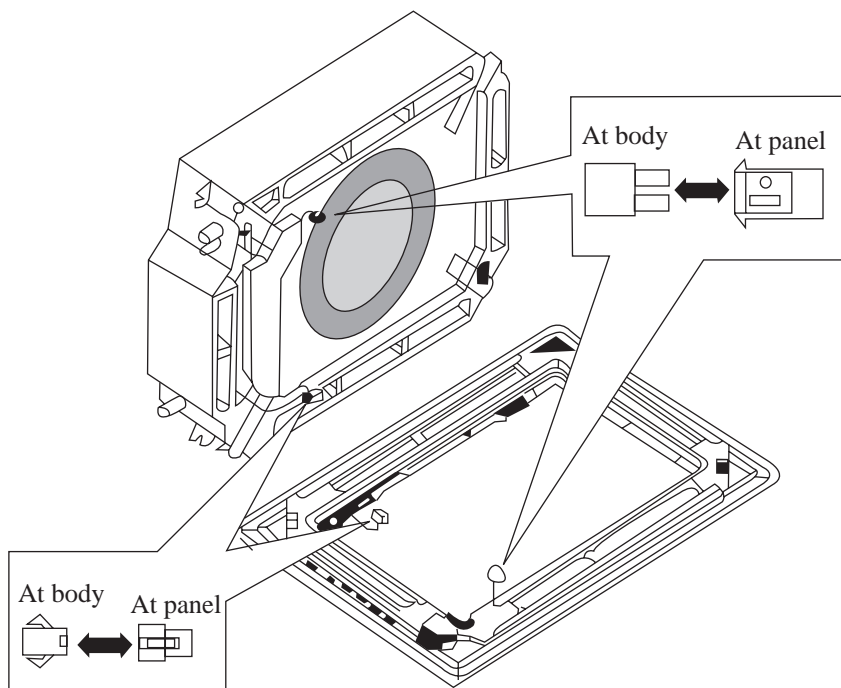

( Fig.7 )

# Outdoor unit installation

## Selecting installation site

- Select an installation site where the following conditions are satisfied and that meets with your customer's approval.
- Places which are well-ventilated.
- Safe places which can withstand the unit's weight and vibration and where the unit can be installed level.
- Places where the unit does not bother next-door neighbors.
- Places where there is no possibility of flammable gas leak.
- Places where things distressed in water do not exist because water drains off the outdoor unit.
- Places where servicing space can be well ensured.
- Places where strong wind can not blow directly to outdoor unit.

## Outdoor unit installation

1. Install the unit firmly with combination of M10 or more bolts and nuts on the foundation that can fully support the weight of the unit and make sure the unit stand vertically.
2. Do not install the unit on the top of building.
3. If there is noise caused by vibration add rubber between the unit and the foundation, Please.
4. When the air conditioner is heating or defrosting, drain water of the outdoor unit to an appropriate place with the drain hose.
5. Fixing method: Fix the outdoor drainage hose head in the hole of the chassis, then connect the drainage hose with the mouth of drainage pipe.

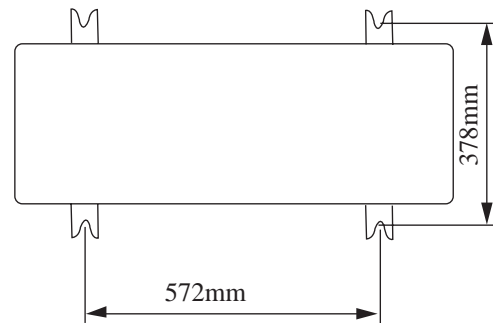

(Fig.8)

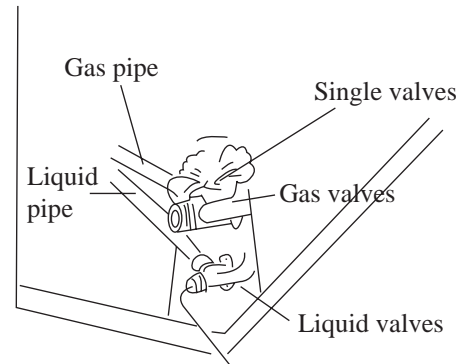

(Fig.9)

## Connecting the pipe.

1. Remove the flare nuts of the valves.
2. Match the piping center, tighten the flare nuts with hand.
3. Tightening the flare nuts with a driver.
4. Remove the nuts of one-way valve.
5. Evacuate from the one-way valve with a vacuum pump until the vacuum meter is 5 Torr, and keep up evacuating 1 hour or more.
6. Turn off the valve and tighten the nuts.
7. Fully open valves. (Fig.9)
8. Tighten the nuts, then check whether there is gas leaking out.

\* Moisture inside pipeline must be less 200 PPM.

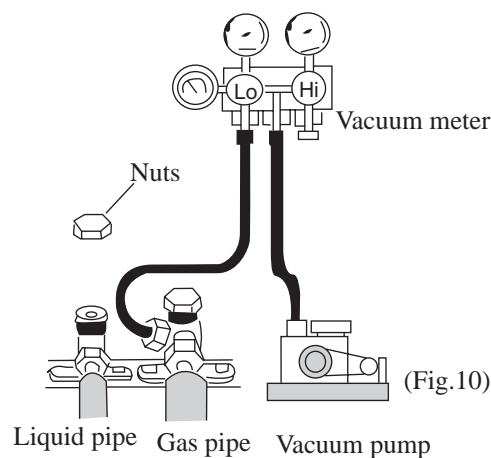

(Fig.10)

# Outdoor unit installation

## Electric wiring

- (1) Read the name plate carefully, then arrange wiring according to the "WIRING DIAGRAM".
- (2) A circuit breaker capable of shutting down power supply to the entire system must be installed.
- (3) Earth properly.
- (4) All wiring must be performed by a skilled electrician according to the "WIRING DIAGRAM". Wrong wiring may cause fire or electric shock.

## Connect the power connecting wires

- (1) Remove the front side plate (Fig.11)
- (2) Break through the hole for wires and put on rubber bush.
- (3) Pull all wires through the rubber bush.
- (4) Connect the outdoor unit according to the "WIRING DIAGRAM" of outdoor unit. Make sure to wire firmly.
- (5) Tighten the wires with clamp and clasp.

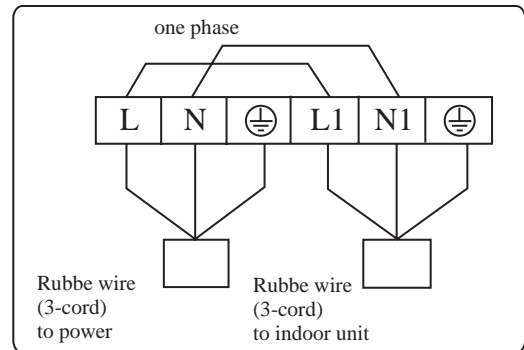

## Note

- (1) Earth the units firmly.
- (2) Wire the units firmly.
- (3) Don't pull the connector too forcefully.
- (4) For cooling only type:

Connect the rubber wire (3-cords) to L.N1 ⊕ of the power supply terminal board (8p) and the rubber wire (5-cords) to L1,L2,L3,N ⊕, of the power supply terminal board (8p) accordingly.

For cooling/heating type:  
Connect the rubber wire (5-cords) to the power supply terminal board (5p) properly.

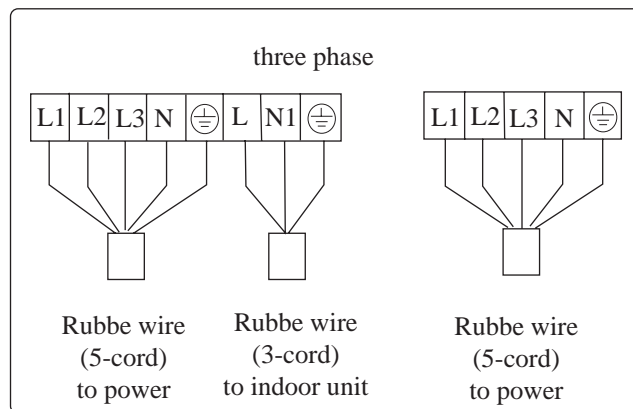

- (5) Connect the other wires properly.
  - Do not pull the wire when fixing it with wire clamp and clasp.
  - Do not let the wire too loose in the outdoor unit compressor compartment.

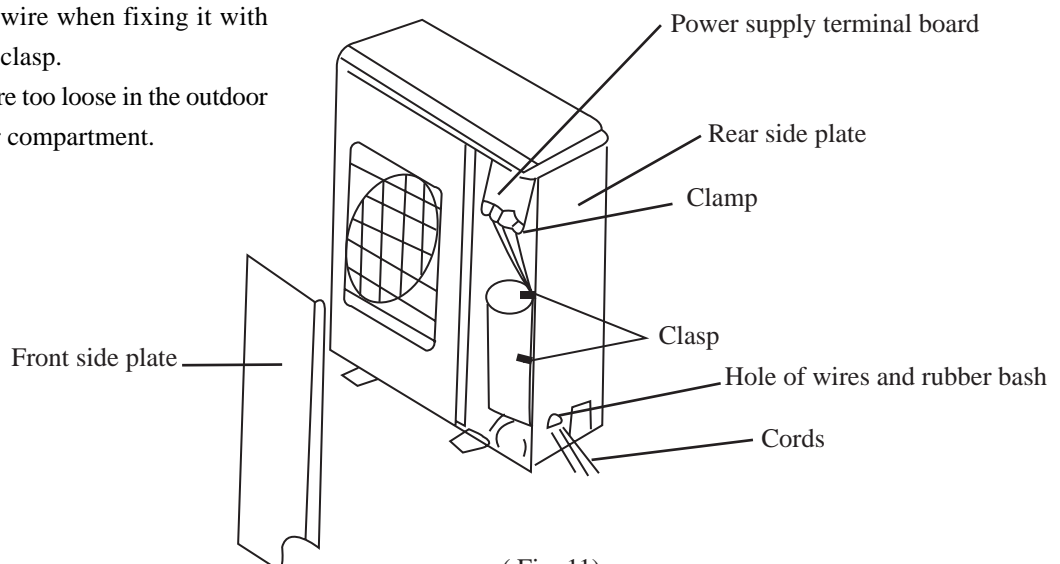

( Fig .11)

# Test and check item after installation

## ● Test operation

### 1. Prepare for test

- (1) Do not turn on the power switch before all installation is finished.
- (2) Connect wires correctly and firmly.
- (3) Open the check valve.
- (4) Remove all dust.

### 2. Testing

- (1) Turn on the power switch and press “1/0” button.
- (2) Press “MODE” button select COOL, HEAT, FAN, etc to test whether it operates normally.

### 3. Emergency operation.

When the batteries fail or when the remote controller is missing, operate as shown below.

- \* On stopping you can press the “AUTO” button on cover NO. II until it is in “AUTO” mode.

The air conditioner select from COOL, HEAT, DRY, FAN modes automatically.

- \* On operating, press the “AUTO” button, the air conditioner will stop.

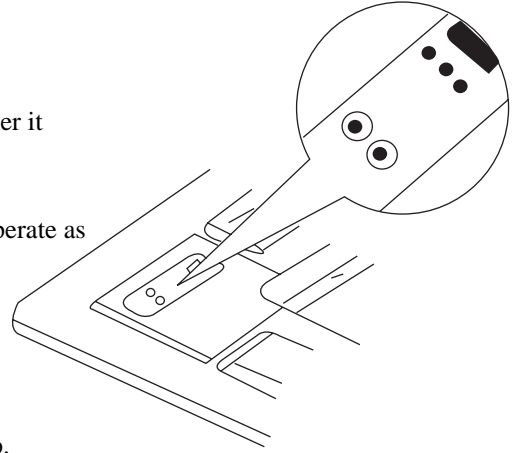

### Note

The “TEST” button on the cover No. II is specially for testing the air conditioner. When pressing it, the air conditioner will be forced to operate or stop. Do not press it when the air conditioner is in normal operation.

**For the following items, take special care during construction and check after installation is finished.**

Items to check	If not properly done, what is likely to happen	Check
Is the indoor unit fixed firmly?	The unit may drop, vibrate or make noise.	
Is the gas leak test finished?	It may result in insufficient cooling.	
Is the unit fully insulated?	Condensate water may drip.	
Does drainage flow smoothly?	Condensate water may drip.	
Does the power supply voltage correspond to that shown on the nameplate?	The unit may malfunction or the components burn out.	
Are wiring and piping correct?	The unit may malfunction or the components burn out.	
Is the unit safely grounded?	Risk of electric leakage.	
Is wiring size according to specifications?	The unit may malfunction or the components burn out.	
Is something blocking the air outlet or intake of either the indoor or outdoor units?	It may result in insufficient cooling.	
Have records of refrigerant piping length and additional refrigerant charge been made?	Volume of refrigerant charge in the system is not clear.	

### Note to the installer

Be sure to instruct the customer how to operate the system and show him/her the attached operation manual.