

MUNDO  CLIMA®

Series 2000
Multisplit 4x1



COOL ONLY:
MUP-062X4C

User's manual

The instructions before use

WARNING

The power plug must be inserted tightly.

Otherwise, it can cause an electric shock, overheating or fire.

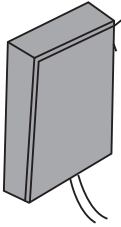

Never splice the power cord or use an extended cord.

It can cause overheating or fire.

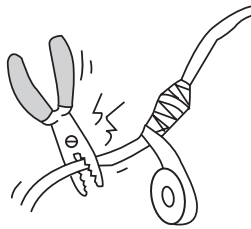

Don't insert your hands or stick into the air intake or outlet vents.

It can cause danger.



Don't apply the cold wind to the body for a long time.

It cause the physical condition deferioration and health problems.



When having a burning smell or smoke, please turn off the power supply and contact with the service center.

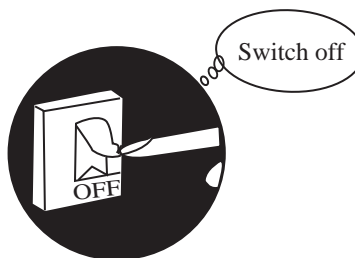

Don't use fuse excluding the fuse of correct capacity.

Improper wire could cause the break down or fire.

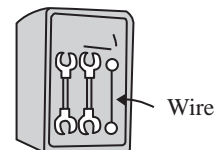

When cleaning, it is necessary to stop driving and turn off the power supply.

It occasionally cause the electric shock.

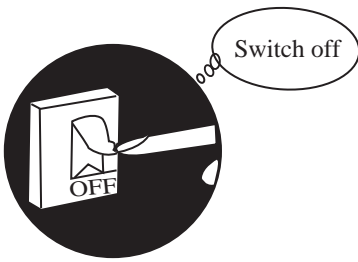

Don't place a space heater near the air conditioner.

Air flow from the air conditioner can cause incomplete combustion to the space heater.



Keep combustible spray away from the units.

It is likely to ignite.

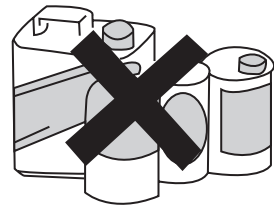

Please note whether the installed stand is firm enough or not.

It leads to the fall of the unit causes the injury etc. occasionally.

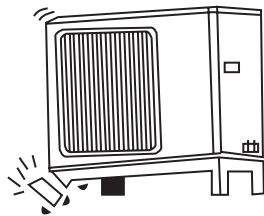

Don't step on the top of the outdoor unit.

As falling off the outdoor unit can be dangerous.

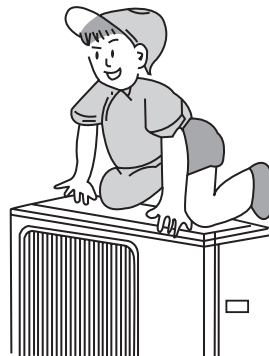

Don't block the air intake or outlet vents of both the outdoor and indoor units.

It can decrease the air conditioning capacity or cause a malfunction.

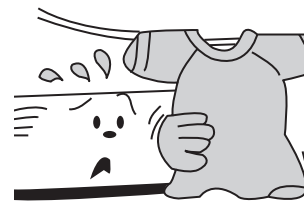

Name and function of each part

● Indoor unit

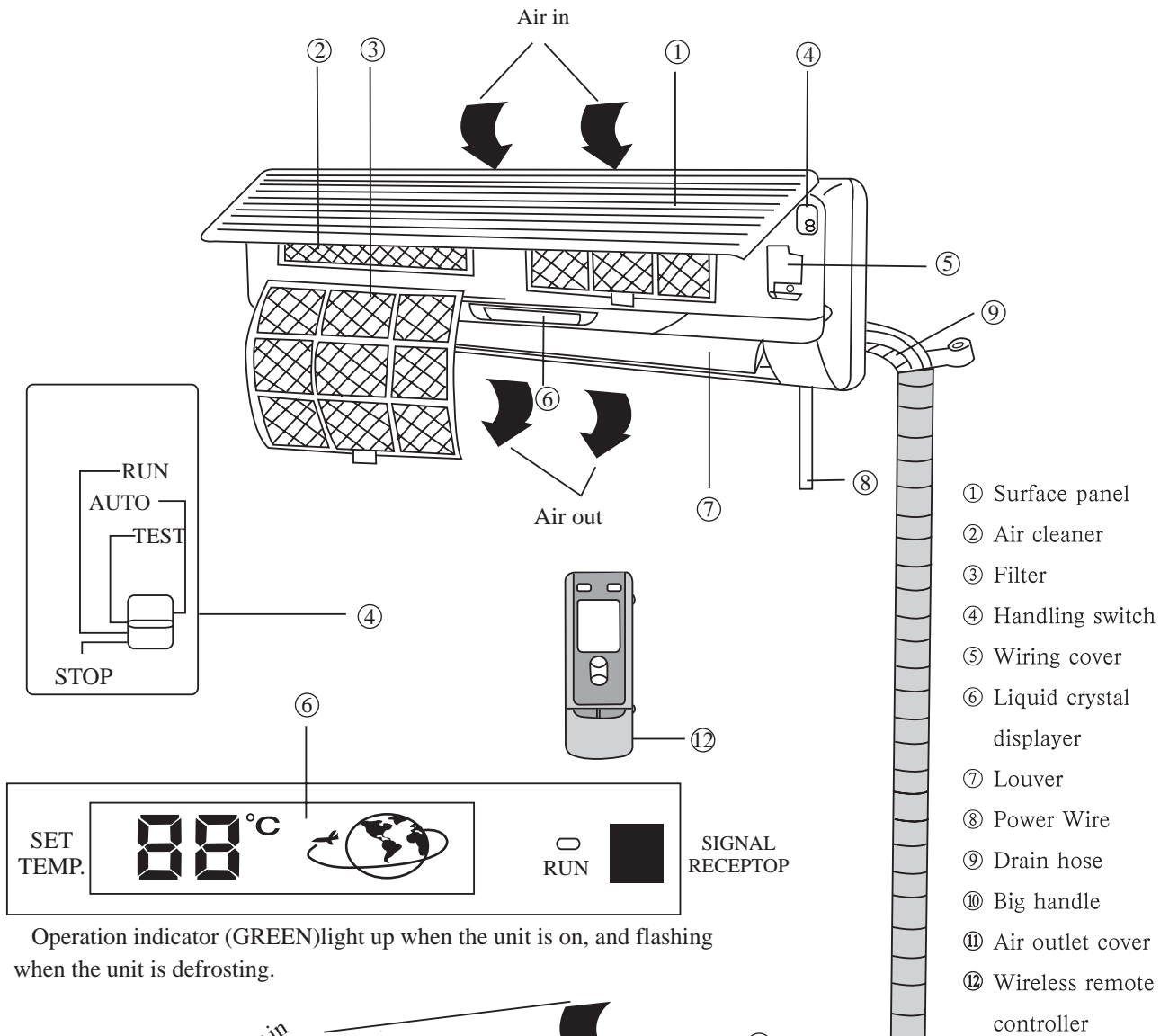

● Outdoor unit

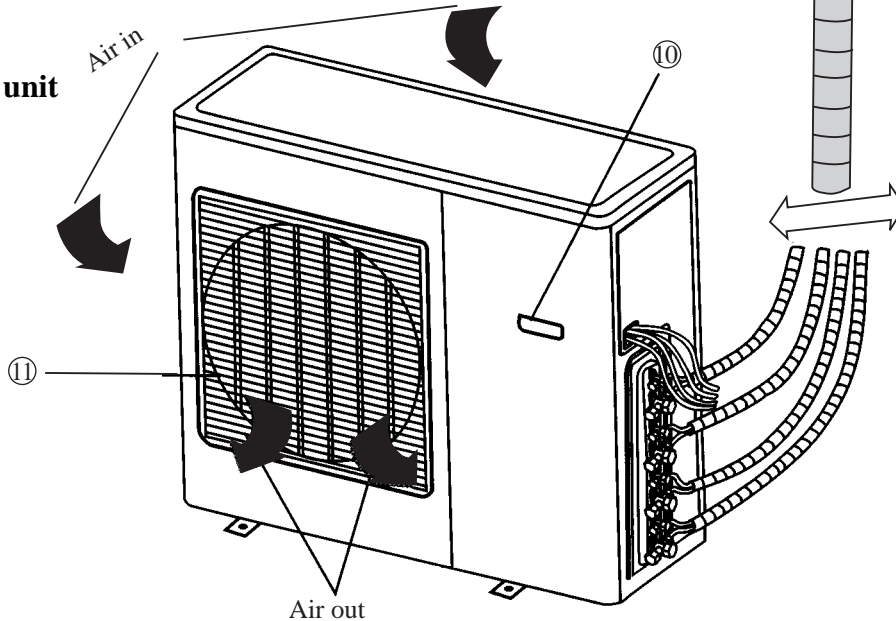

Remote control operation procedure

● Name and Function-Remote control

Note:

- Be sure that there are no obstructions.
- The remote control signal can be received at a distance of up to about 10m.
- Don't drop or throw the remote control.
- Don't place the remote control in a location exposed to direct sunlight.
- This type is just useful to cool mode only.

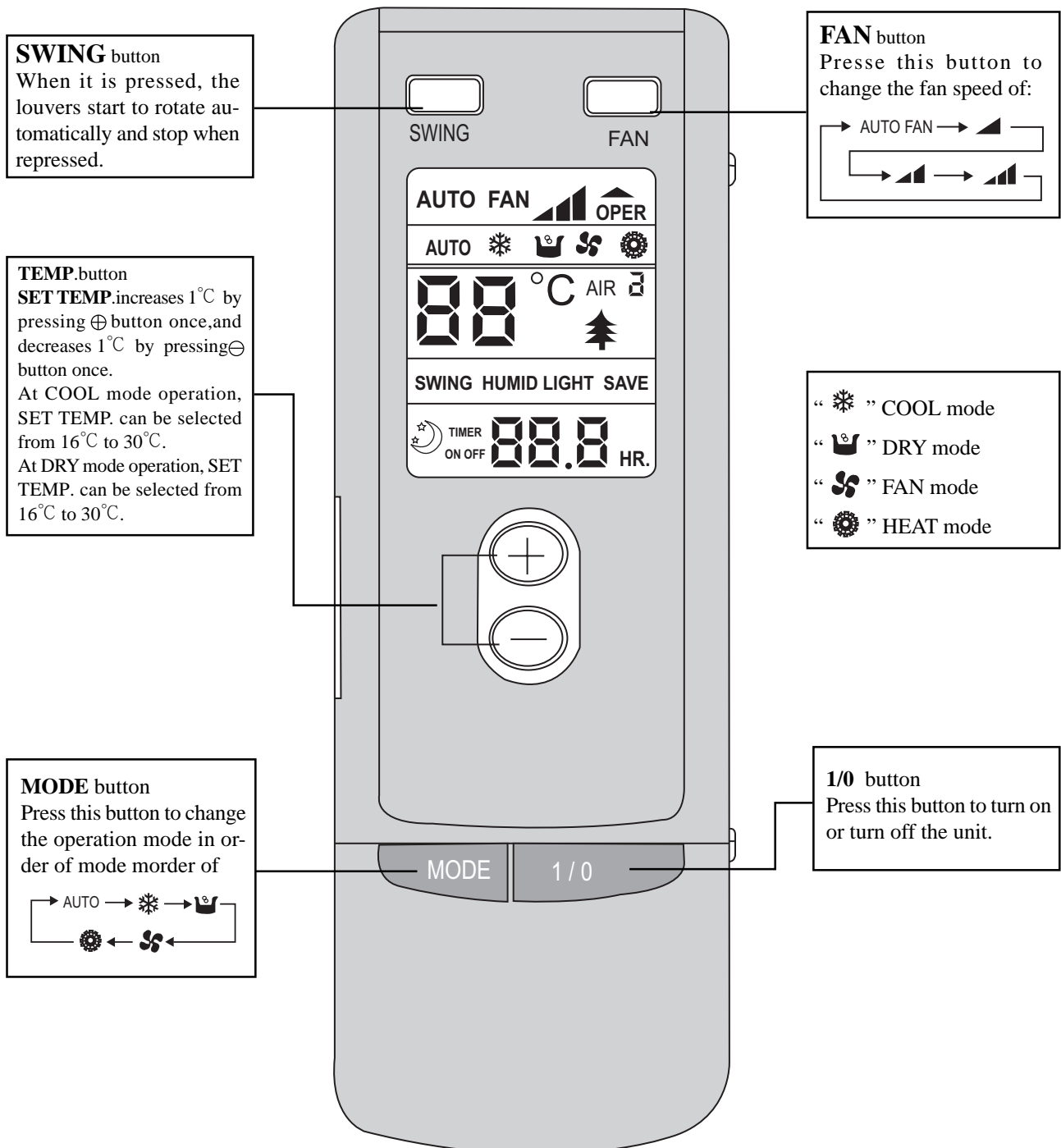

● Name and Function-Remote control (Remove the cover)

Note: This type of remote controller is a kind of new current controller. Some buttons of the controller which are not available to this Air conditioner will not be described below.

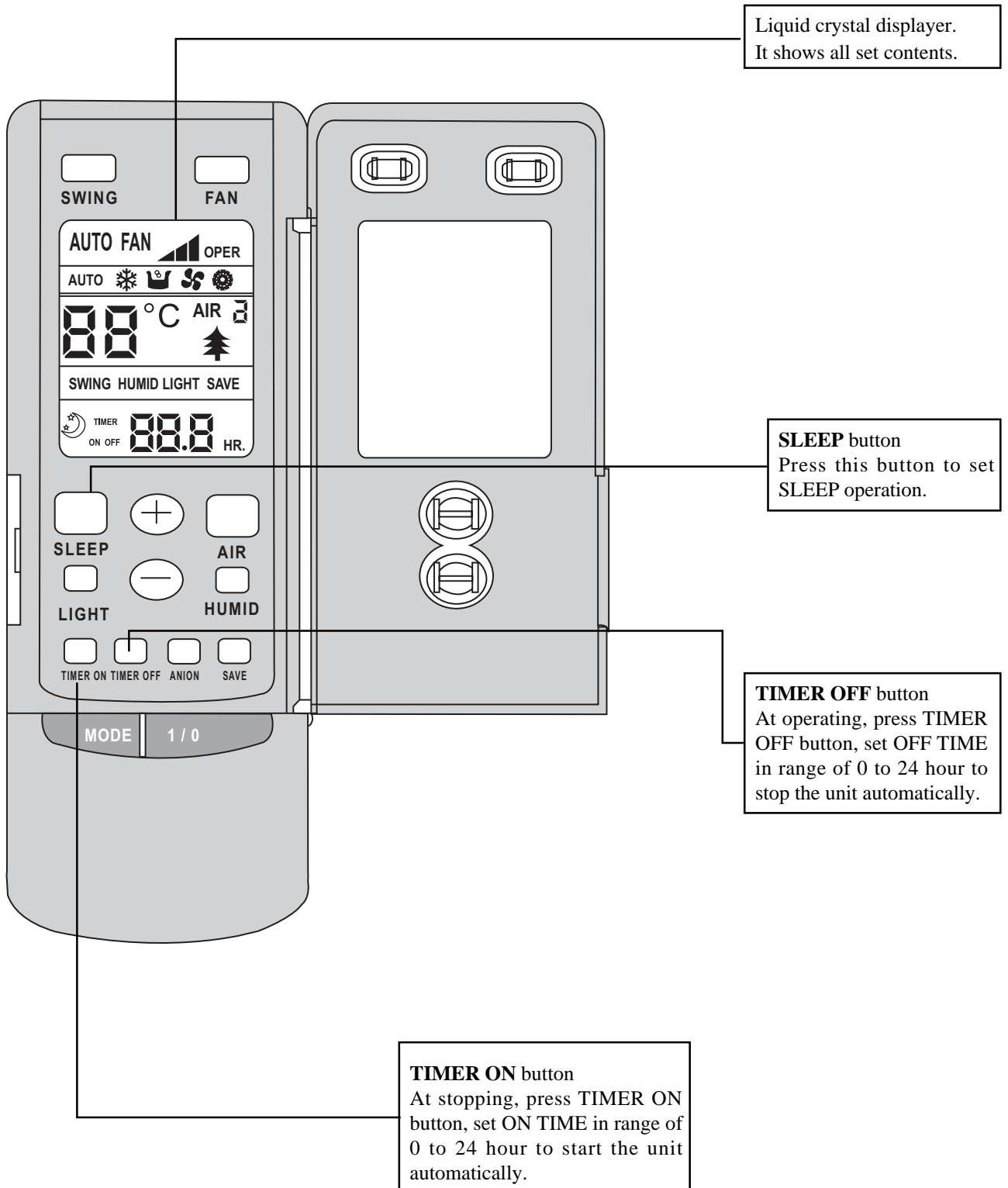

● COOL mode operation procedure

- According to difference between room temp. and set temp., microcomputer can control cooling on or not.
- If room temp. is higher than set temp., compressor runs at COOL mode.
- If room temp. is lower than set temp., compressor stops and only indoor fan motor runs.
- SET TEMP. should be in range of 16°C to 30°C.

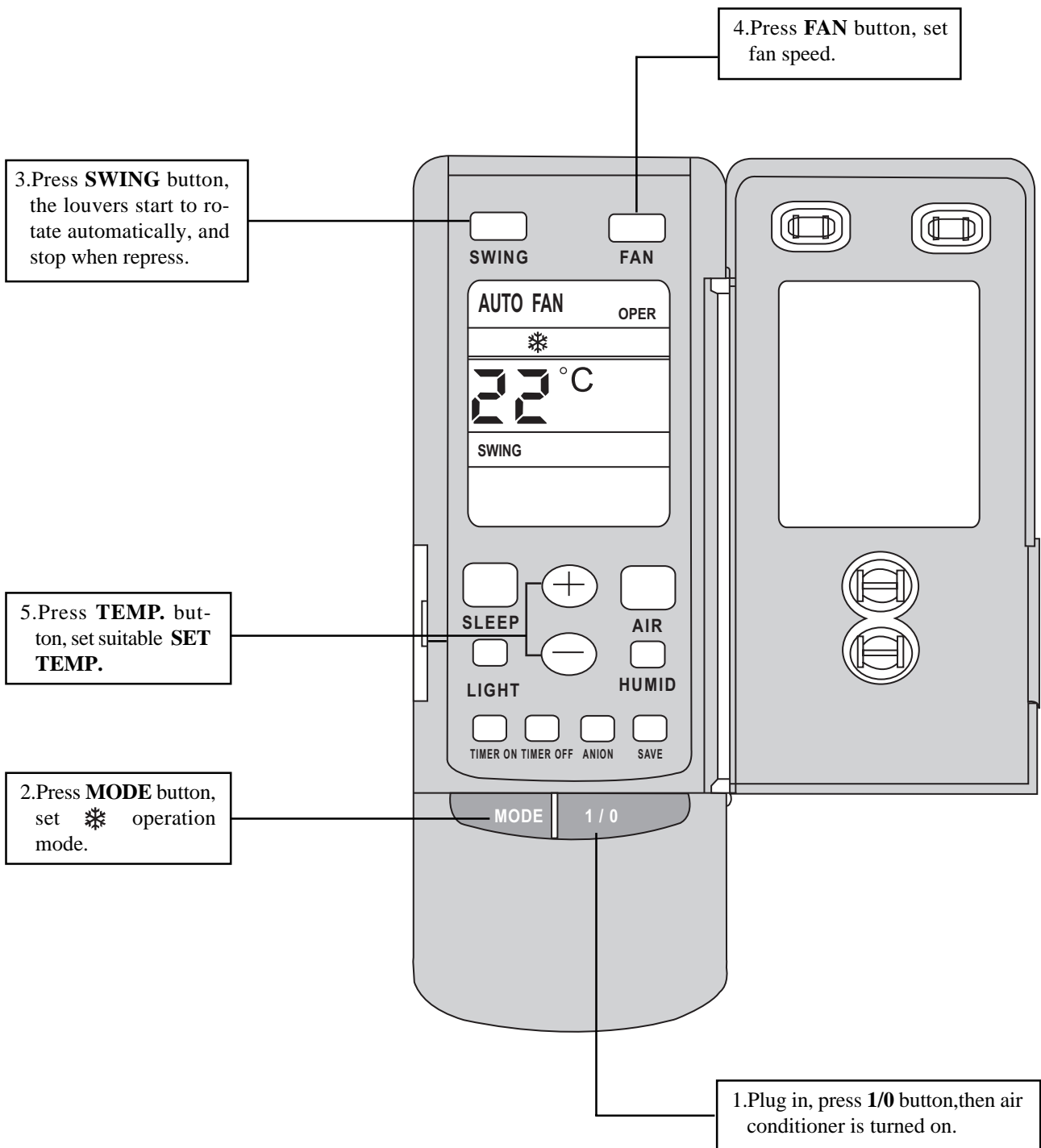

● DRY mode operation procedure

- If room temp. is lower than set temp., compressor ,outdoor and indoor fan mortar stop. If room temp. is between $\pm 2^{\circ}\text{C}$ of set temp., Air conditioner is drying.If room temp. is higher than set temp. it's at COOL mode.
- SET TEMP. should be in range of 16°C to 30°C .

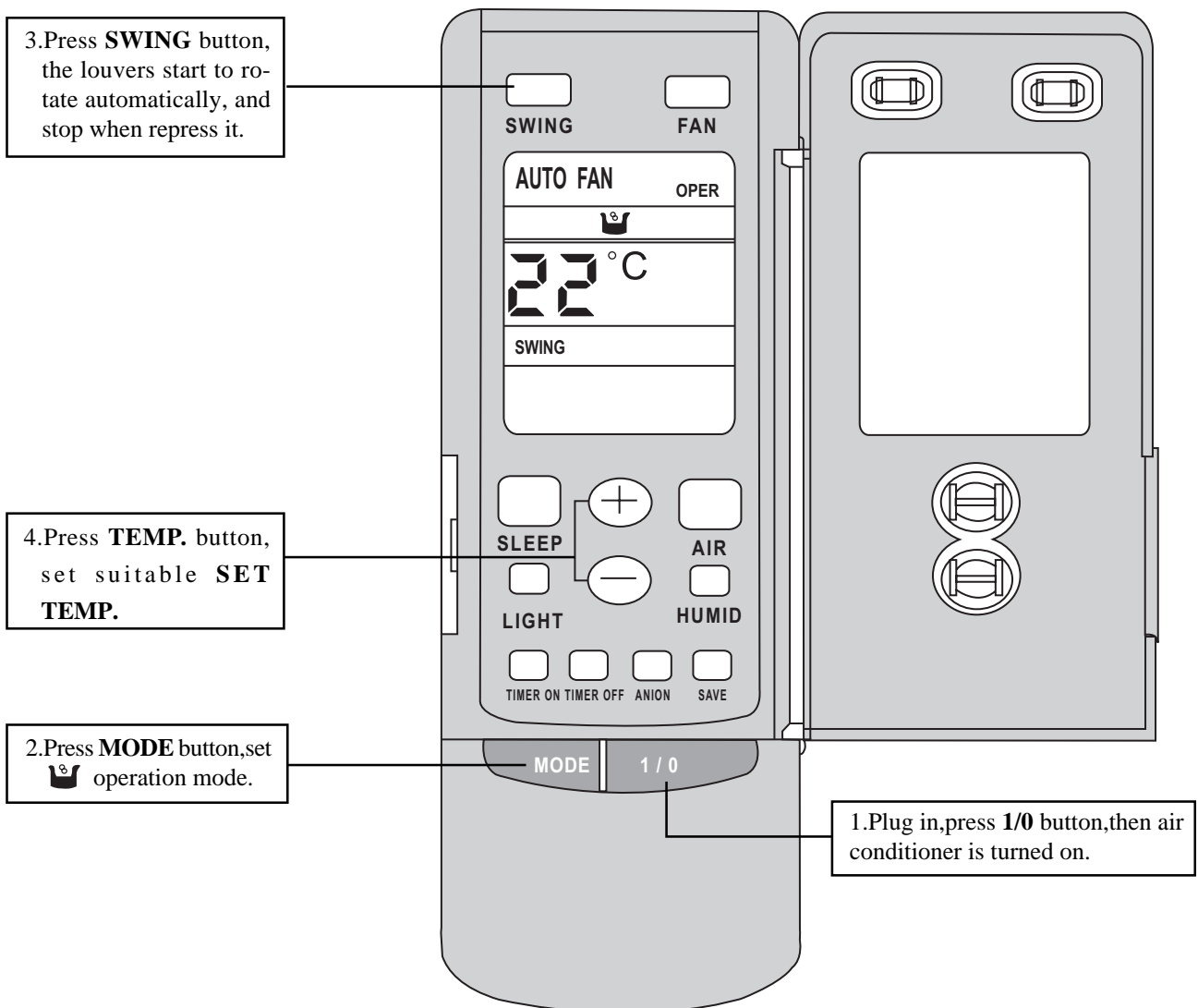

● AUTO mode operation procedure

- At AUTO mode operation, standard SET TEMP. is 25°C for COOL mode .

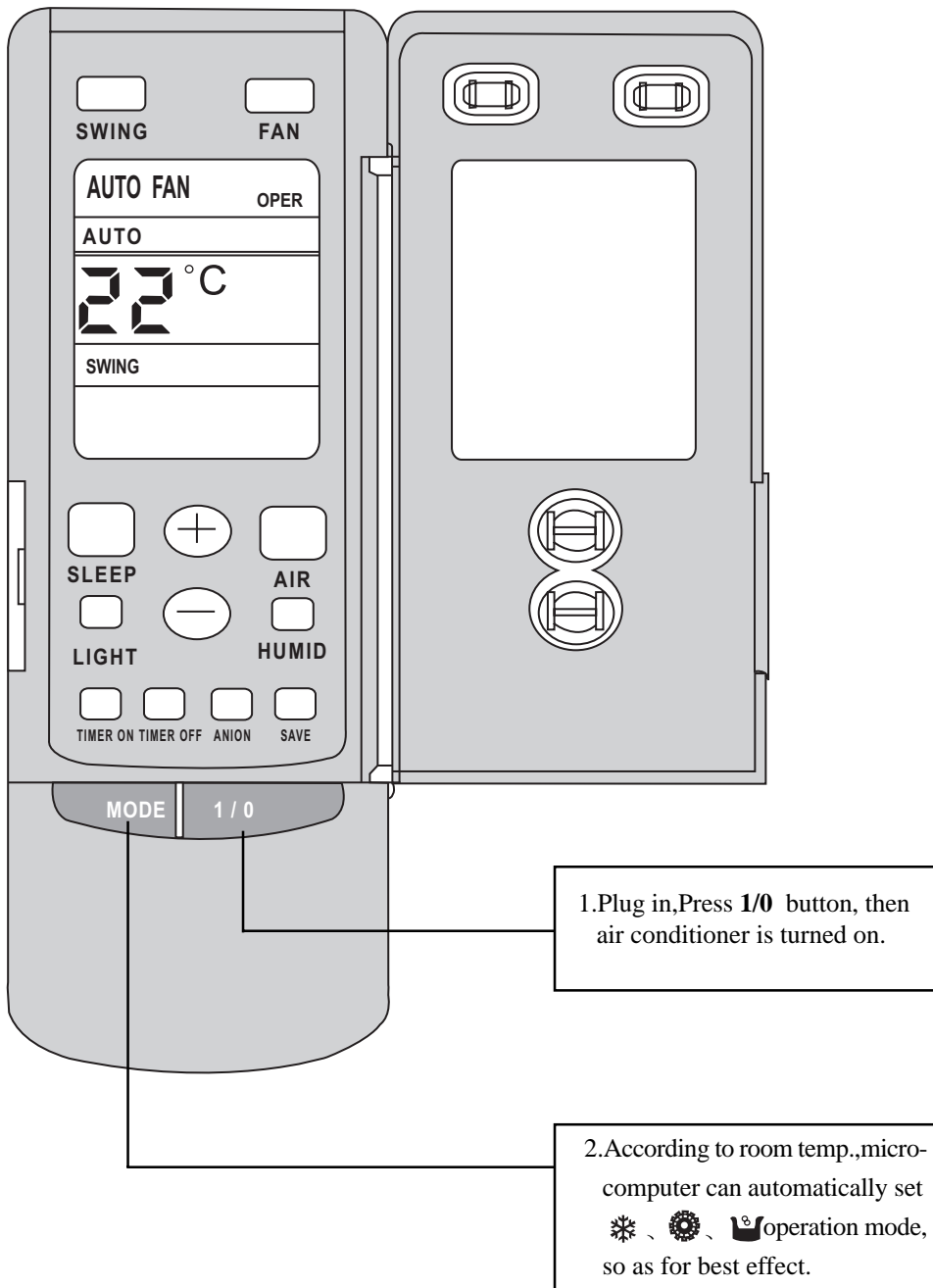

TIMER mode operation procedure

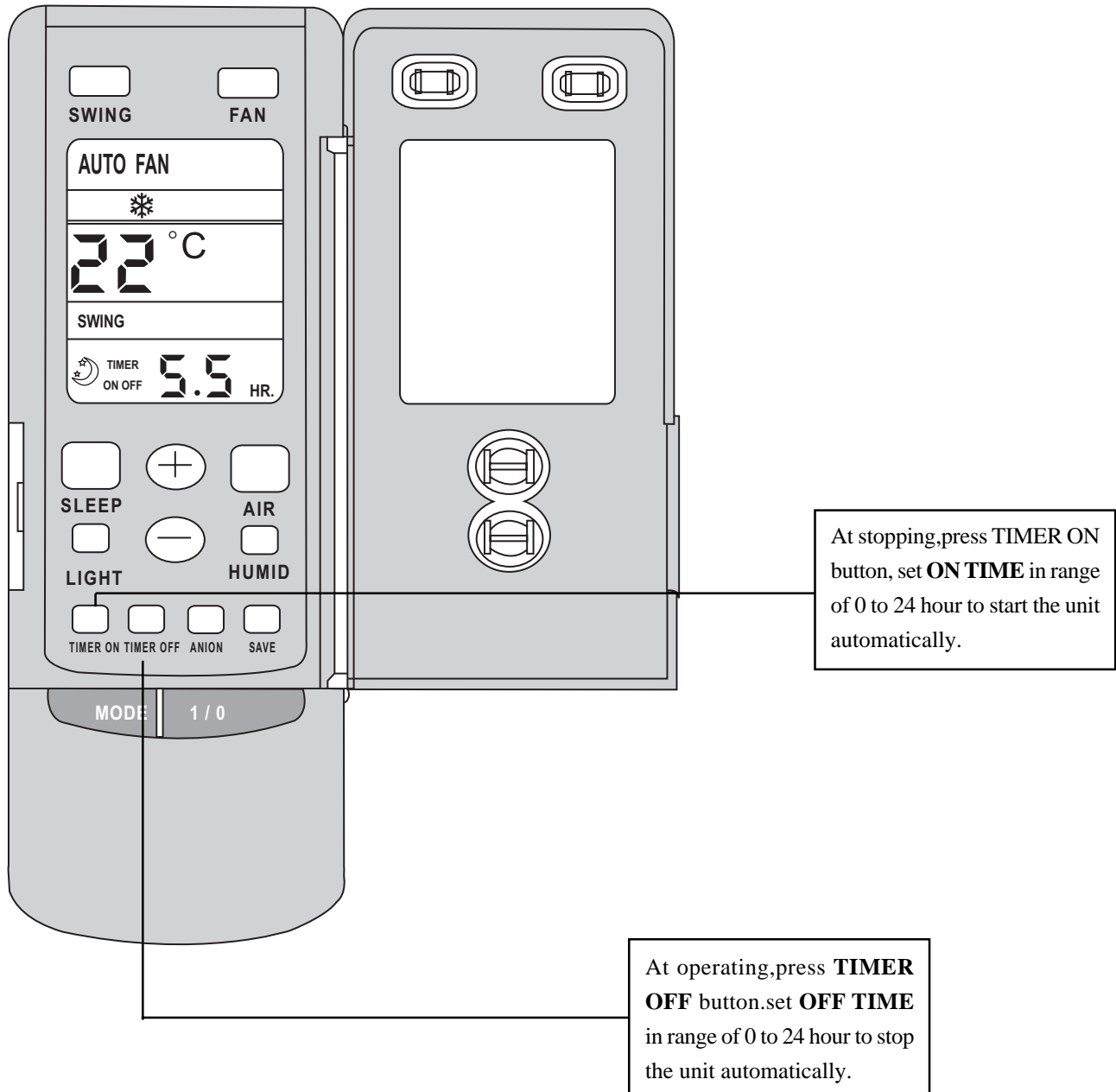

● SLEEP mode operation procedure

- When the unit is cooling or drying, if **SLEEP** operation is set, **SET TEMP.** would increase 1°C in 1 hour and 2°C in 2 hour. Indoor fan motor runs at low speed.
- When the unit is heating , if **SLEEP** operation is set, **SET TEMP.** would decrease 1°C ,in 1 hour and 1°C 2 hours. Indoor fan motor runs at low speed.

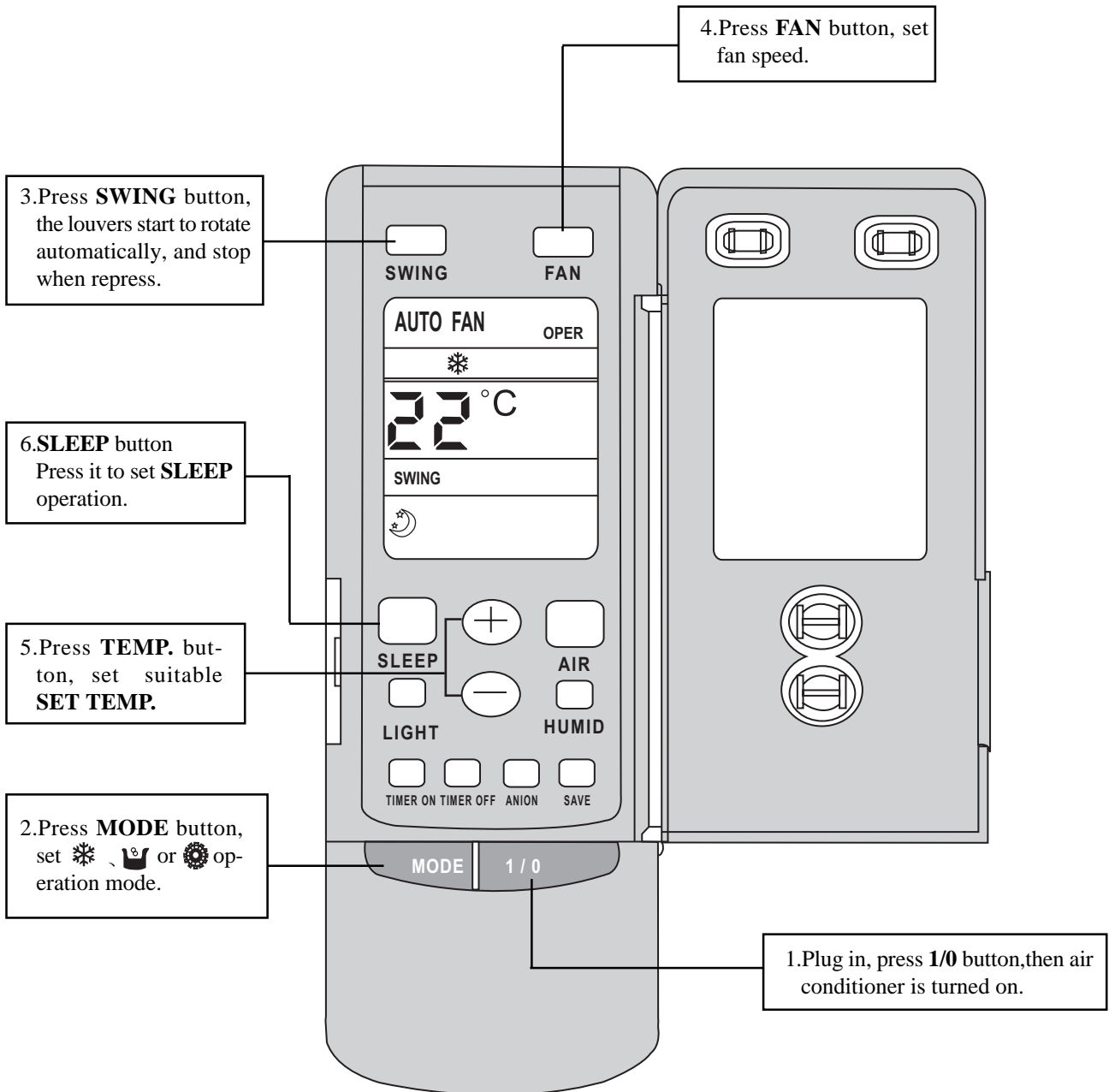

● How to insert batteries

1. Remove the cover from the back of the remote control.
2. Insert the two batteries (Two AAA dry - cell batteries) and press button “ACL”.
3. Re - attach the cover.

NOTE:

Don't confuse the new and worn or different batteries.

Remove batteries when not in use for a longtime.

The remote control signal can be received at a distance of up to about 10m.

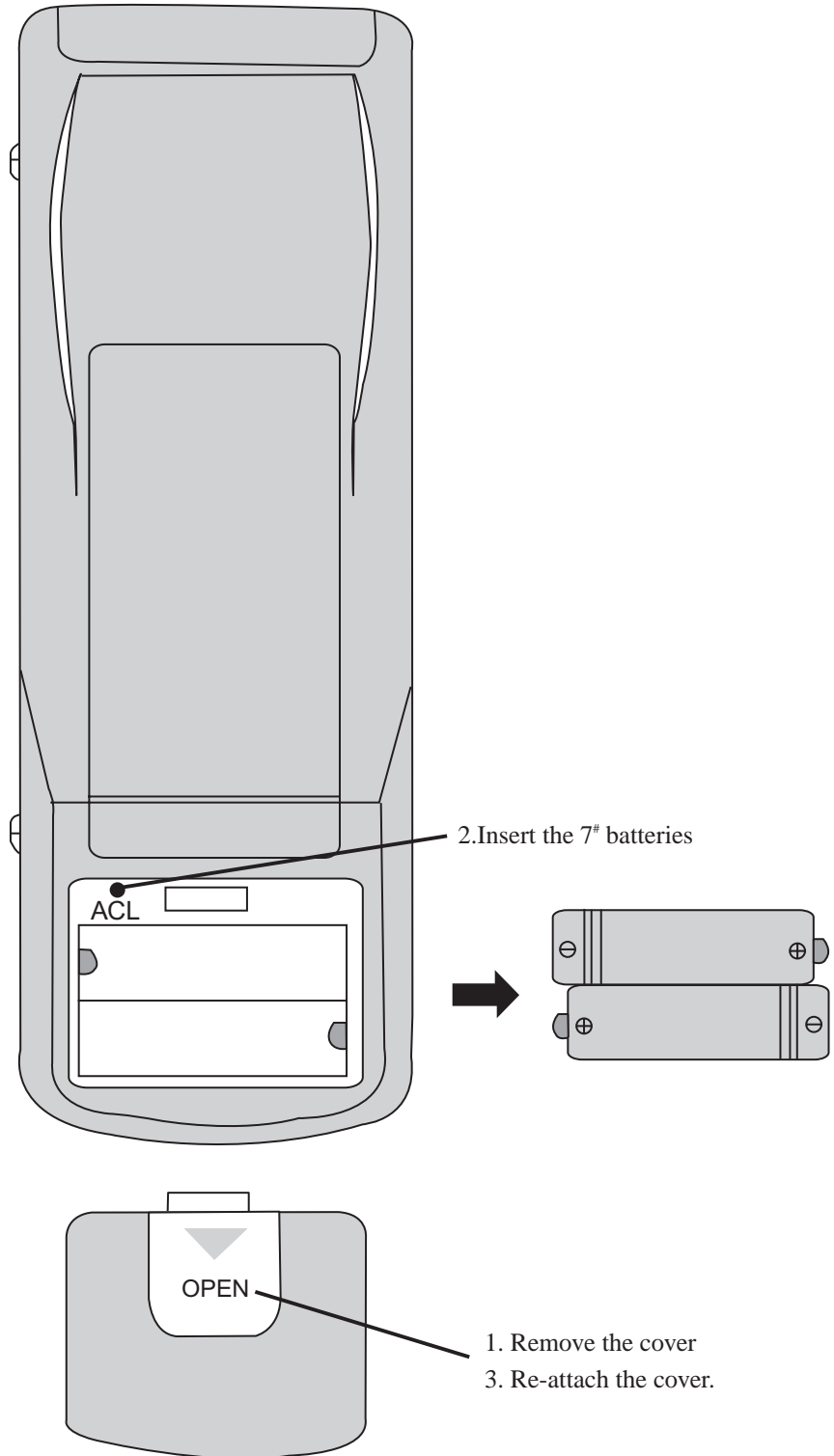

USER NOTICES

● Note: The climate type is T1 (18°C ~ 43°C)

- **Select the most appropriate temperature.**
It can preclude the electricity wasted.



- **The air flow direction can be adjusted appropriately.** The louvers can be adjusted downward at heating operation, and upward at cooling operation.

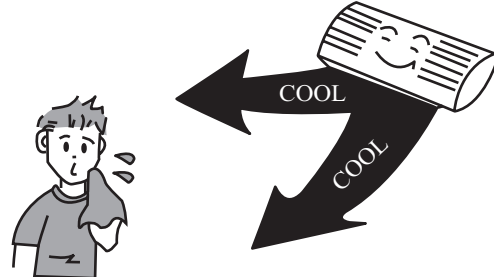

- **Don't leave windows and doors open while operating the air conditioner for a longtime.**
It can decrease the air conditioning capacity.

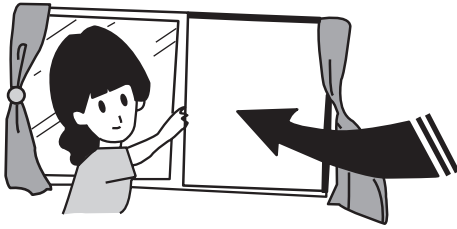

- **Don't blow the wind to animals and plants directly.**
It can cause a bad influence to them.

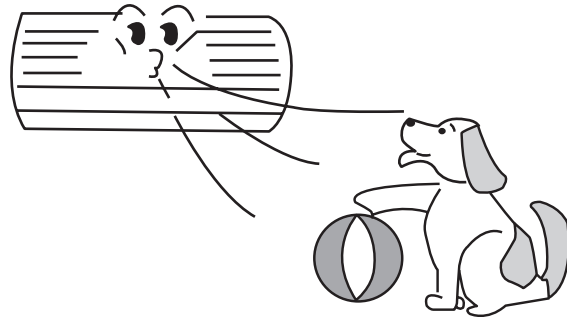

- **Splashing water on the air conditioner can cause an electric shock and mal-function.**

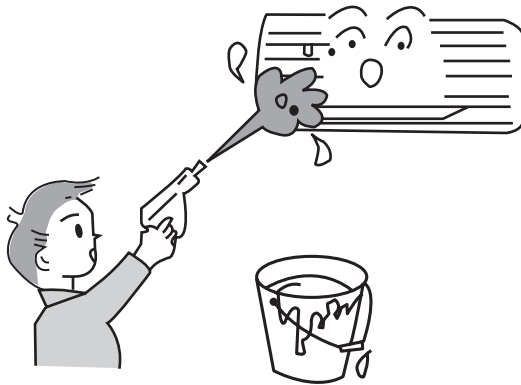

- **The ground must be connected.**
Don't connect the earth wire to gas or water pipes, lightning rods or telephone earth lines.

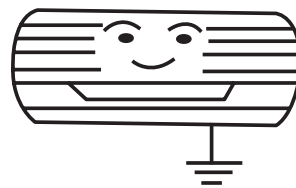

- **Air conditioner should be operated with stable voltage in range of 206-244V 1ph. otherwise, compressor would vibrate terribly to damage refrigeration system.**

50Hz
220-230V~

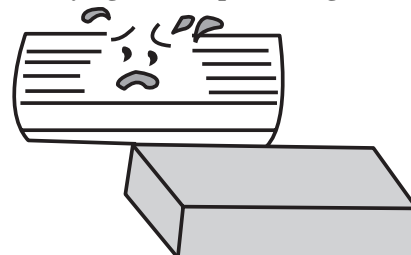

- **Don't use the air conditioner for other purposes, such as drying clothes, preserving foods, etc.**



Care and Maintenance

CAUTION

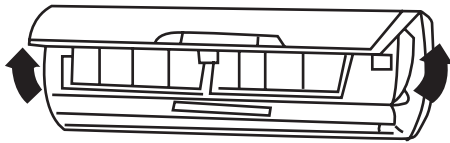
- Turn power off and pull out the power plug before cleaning air conditioner.
- Don't sprinkle water on the indoor unit and the outdoor unit for cleaning.
- Wipe the units with a dry soft cloth, or a cloth slightly moistened with water or cleanser.

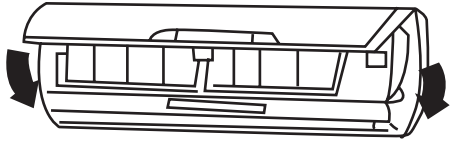
Cleaning surface panel	
1. Pull along the direction of arrows to take down surface panel.	
2. Washing Wipe with a cloth slightly moistened with water or cleanser, and then dry it in the shade. NOTE: Never use water above 45°C to wash the panel, or it could cause deformation or discoloration.	
3. Install surface panel Cover the surface panel and clasp it.	

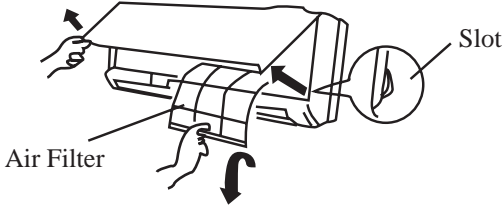
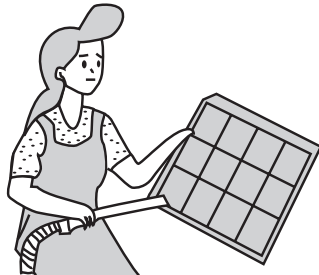
Cleaning the Air Filters (Recommended once every three weeks)	
1. Open the surface panel, hold the tab of Air Filter and raise it slightly, and then take it out.	
2. Cleaning To clear the dust adhering to the filters, you can either use a vacuum cleaner, or wash them with water and dry it in the shade. NOTE: • Never use water above 45°C to wash the filters, or it could cause deformation or discoloration.	

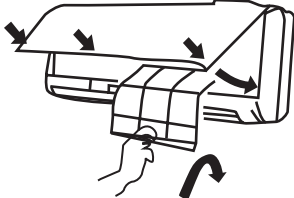
<p>3.Reinsert the filters Reinsert the filters with side marked “FRONT” facing forward.</p>	
--	--

Replacement of Air cleaner
● Recommended once every Six months,and the alternate filters can be found in the service center.

<p>1.Remove the Air Filters</p>	<p>(Refer to the first step of “cleaning the Air Filters”)</p>
<p>2.Replace the Air cleaner Take off the packed bag of Air purifying Filters,and then put new Filters into the Filter frame.</p>	<p>Air cleaner</p>  <p>NOTE:Be careful not to injure yourself on the fins</p>
<p>3.Reinsert the filters.</p>	<p>(Refer to the third step of “cleaning the Air Filters”)</p>

Preparation before use





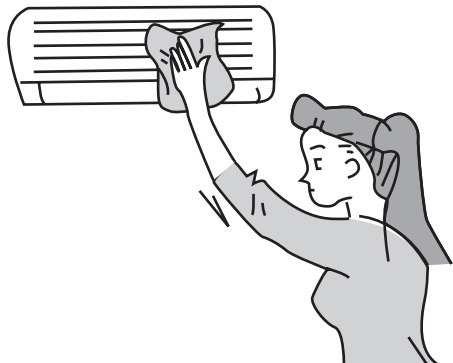

<p>1.Be sure that nothing obstructs the air outlet and in-take vents. 2.Check that whether ground wire is properly connected or not. 3.Replace filters if necessary. 4.Turn main power on at least 6 hours before starting actual operation.This will ensure a smooth starting of the units.</p>	
--	--

Maintain after use

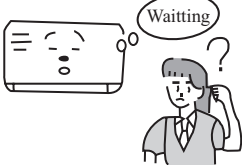
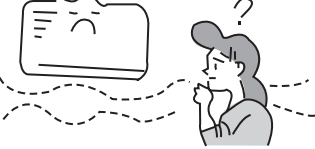
<p>1.Clean filters and other parts. 2.Turn main power off. 3.Clean dust from the outdoor unit. 4.Repaint the rubiginous place on the outdoor unit to prevent it from spreading.</p>	
---	--

Troubleshooting

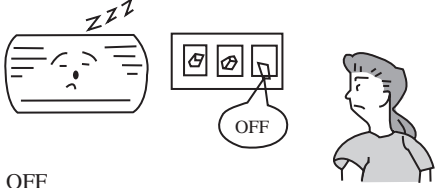
Check the following before requesting on service center if the malfunction occurs.

Phenomenon	Trouble Shooting
 <p>Indoor unit does not operate immediately when the air conditioner is restarted.</p>	<p>Once the air conditioner is stopped, it will not operate in approximately 3 minutes to protect itself.</p>
 <p>There's unusual smell blowing from the outlet after operation is started.</p>	<p>This is caused by the odors in the room which have been breathed into the air conditioner.</p>
 <p>Sound of water flow can be heard during operation.</p>	<p>This is caused by the refrigerant flowing inside the unit.</p>
 <p>Mist emitted during cooling operation.</p>	<p>Because the air of the room is cooled down rapidly by the cold wind and it looks like the fog.</p>
 <p>Creaking noise can be heard when start or stop the unit.</p>	<p>This is caused by the deformation of plastic due to the change of temperature.</p>
 <p>Air conditioner does not operate at all.</p>	<ul style="list-style-type: none"> • Has the power been shut down? • Is the wiring loose? • Is the leakage protection switch in operation? • Is voltage higher than 244V or lower than 206V? • Is TIMER ON in operation?
 <p>Cooling Heating efficiency is not good.</p>	<ul style="list-style-type: none"> • Is SET TEMP. suitable? • Is air inlet or outlet obstructed? • Are air filters dirty? • Is indoor fan speed set at low speed? • Is there any other heat source in your room?
 <p>Wireless remote controller is not available.</p>	<ul style="list-style-type: none"> • Is the remote control unit out of effective distance to the indoor unit? • Replace the worn batteries of wireless remote controller. • Are there any obstructions between the wireless remote controller and the signal receptor?

Immediately stop all operations and plug out,contact with service center of MUNDOCLIMA in following situations.



- Unusual noise can be heard during operation.
- Power fuse or switch often breaks.
- Carelessly splash water or something into air conditioner.
- Electrical lines and power plug are very hot.
- Wind blowing from the outlet smells terrible during operation.

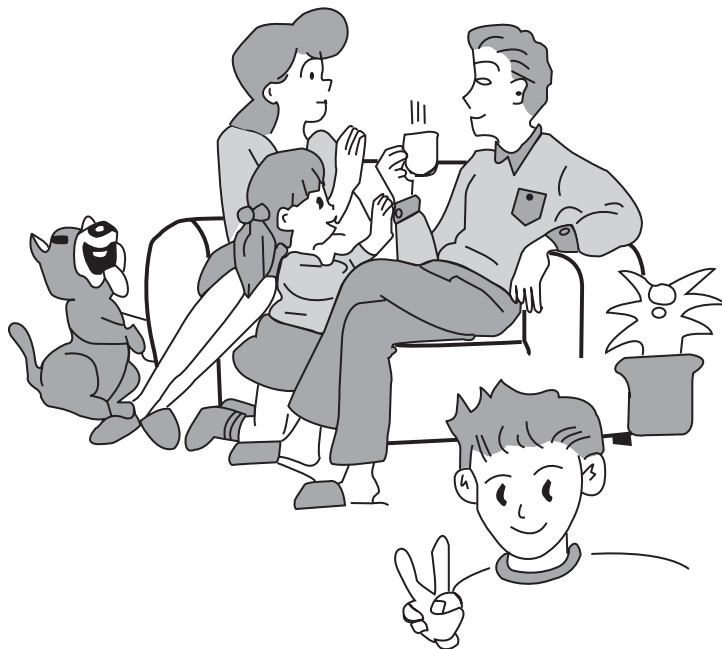



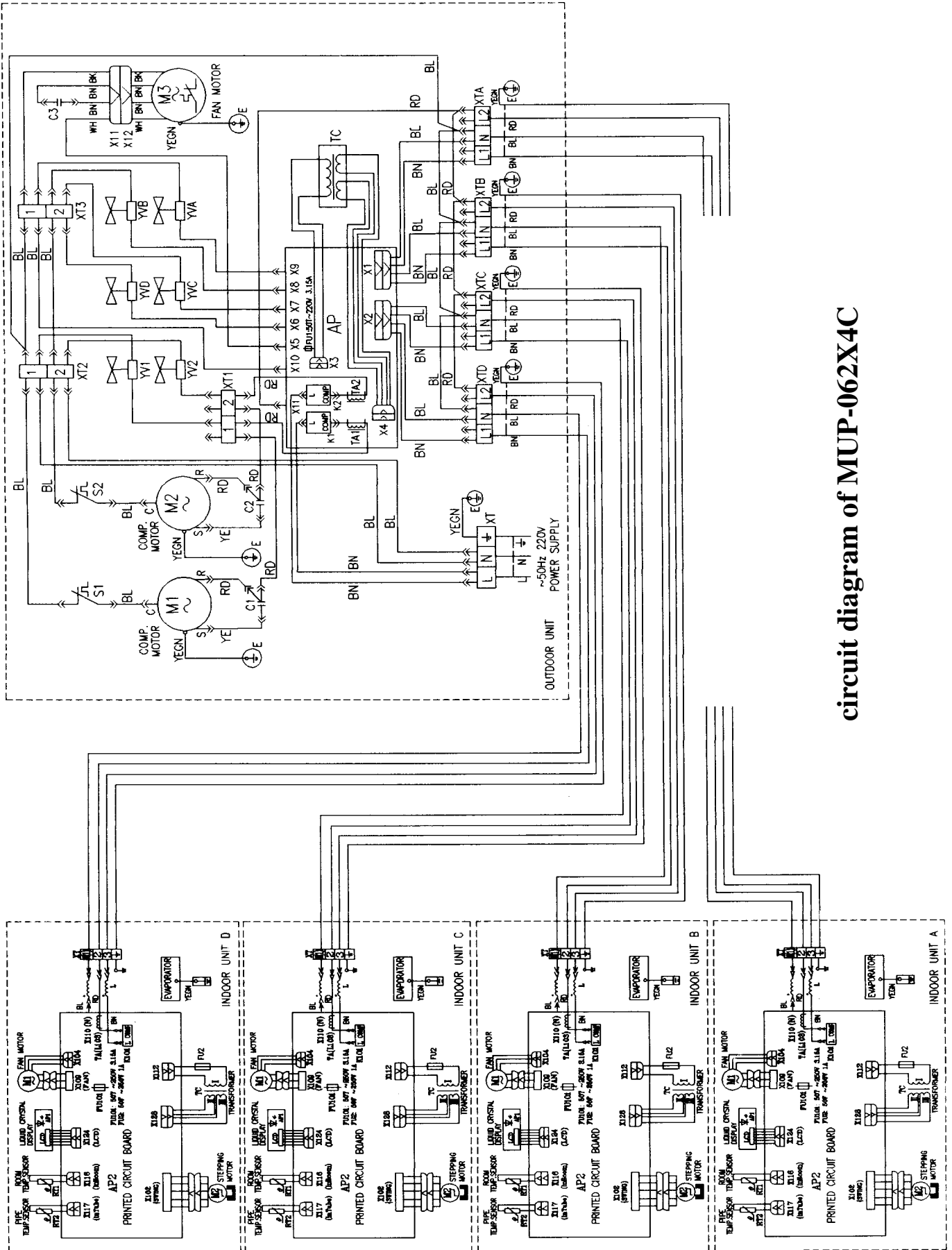







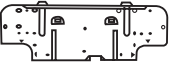

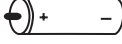
Circuit Diagram

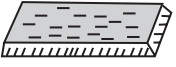
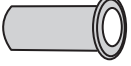

circuit diagram of MUP-062X4C

Accessories and Installation diagram

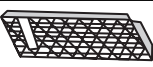
● Accessories (Check that all accessory parts are present before installation)

No.	Part name	Diagram	Qty	specification	Memo
1	Rear panel		1		
2	Wireless remote controller		1		
3	Battery		2	7# 1.5V	
4	Power connection cord		1	YZW300/500 3 × 2.5	
5	Control cord		4	4G 1.0	
6	Tapping screw		10	ST4.2 × 25	Fix the rear panel
7	Plastics drain hose		1	L = 2m	Packaged with connection piping
8	Gum type sealer		1	120 × 65 × 25	
9	Piping-hole sleeve		1		Packaged with connection piping
10	Wrapping tape		2	30 × 10	Packaged with connection piping
11	Connection piping		1	∅ 6/∅9.5	Packaged with connection piping
12	Thermal insulation hose		1	∅ 35 × 500	
13	Air cleaner		2		Packaged with indoor unit
14	Plastic square ring		1		Packaged with Outdoor unit

* Be sure to use the exclusive accessories list above in the installation, or it will lead to water leakage ,electric shock, fire,etc.

● Installation dimension diagram

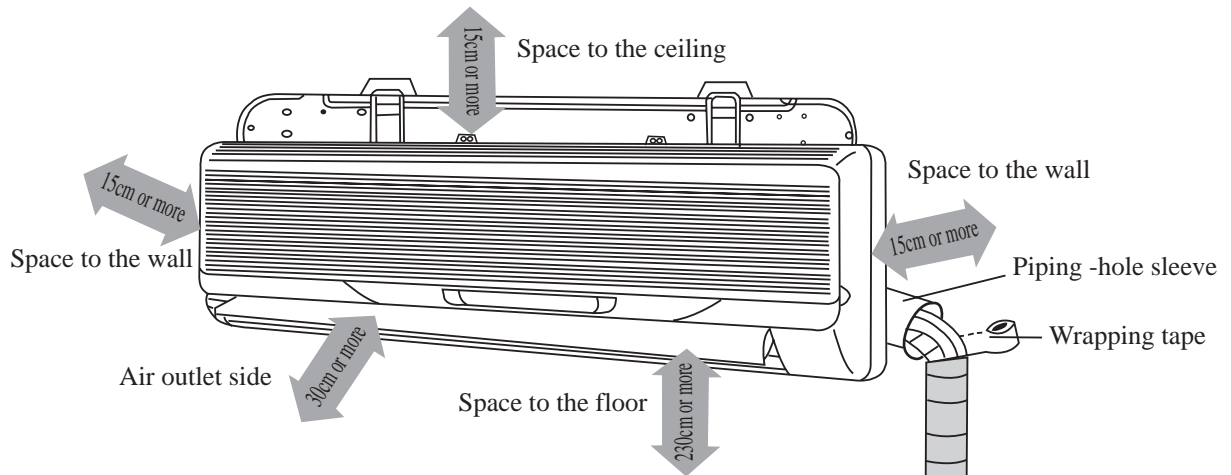

IMPORTANT NOTES

- * The installation must be done by trained and qualified service personnel with reliability according to this manual.
- * Contact with service center of MUNDOLIMA before installation to avoid the mal-function due to unprofessional installation.
- * When picking up and moving the units, you must be guided by trained and qualified personnel.

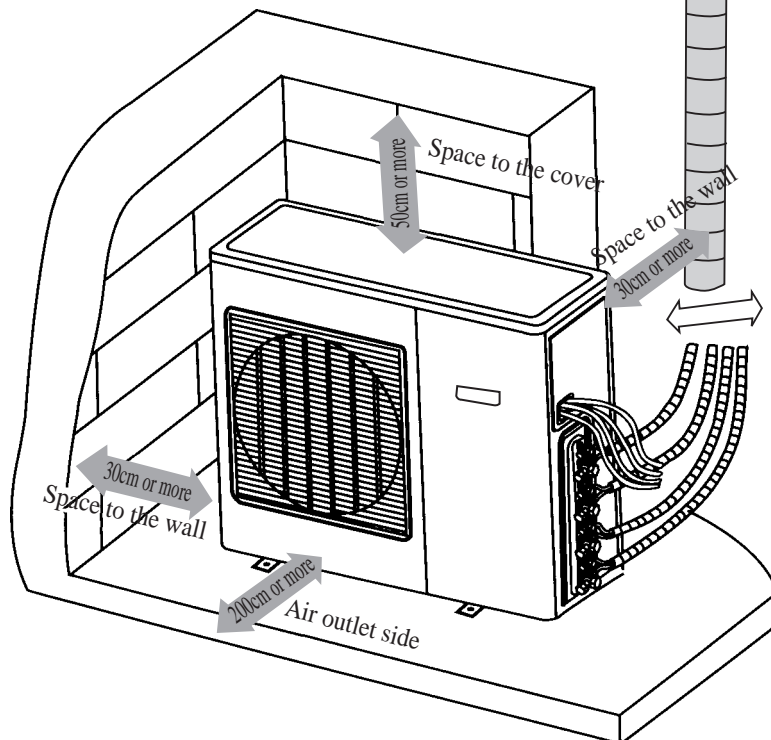

Installation location

● Indoor unit

1. The inlet and outlet should not be covered so that the outflow air can reach all parts of the room.
2. Install in a location where is permitting easy connection with the outdoor unit.
3. A location from which the condensation water can be drained out conveniently.
4. Avoid a location where there is heat source, high humidity or inflammable gas.
5. Install in a location where is strong enough to withstand the full weight and vibration of the unit.
6. Be sure that the installation conforms to the installation dimension diagram.
7. Be sure to leave enough space to allow access for routine maintenance.
8. Install in a location where is 1m or more away from other electric appliances such as television, audio device, etc.
9. Select location where is easy to remove and clean the filter.
10. Be sure that the distance from the location to the ground is more than 2.3m.

● Outdoor unit

1. Select location from which noise and outflow air emitted by unit will not inconvenience neighbors.
2. Select location where there should be sufficient ventilation.
3. The inlet and outlet should not be covered.
4. The location should be able to withstand the full weight and vibration of the outdoor unit.
5. There should be no danger of flammable gas or corrosive gas leaks.
6. Be sure that the installation conforms to the installation dimension diagram.

NOTE:

Install in the following place may cause mal - function. If it is unavoidable, contact with service center of MUNDOCLIMA please.

- Place where oil (machine oil) is used.
- The place where a lot of salinities such as coast exists.
- Place where a sulfured gas such as the hot spring zones is generated.
- Place where high - frequency waves are generated by radio equipment, welders and medical equipment.
- Other place with special circumstance.



Install the indoor unit

● Install the rear panel

1. Always mount the rear panel horizontally.
2. Fix the rear panel on the selected location with screws supplied.
3. Be sure that the rear panel has been fixed firmly enough to withstand the weight of an adult of 60kg, furthermore, the weight should be evenly shared by each screw.

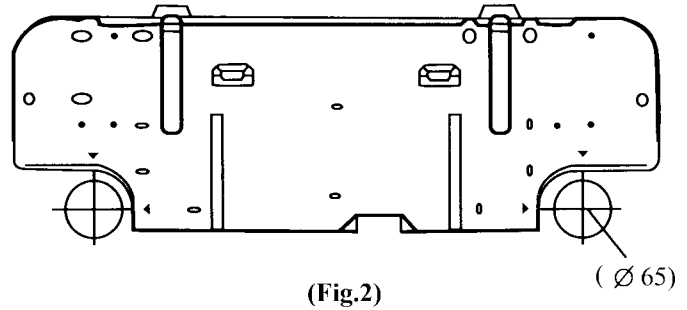

● Install the drain hose

1. For well draining, the drain hose should be placed at a downward slant.
2. Do not wrench or bend the drain hose or flood its end by water.

● Install the piping hole

1. Make the piping hole (Ø 65) in the wall at a slight downward slant to the outdoor side. The center of the hole should be determined refer to Fig.2.
2. Insert the piping - hole sleeve into the hole to prevent the connection piping and wiring from being damaged when passing through the hole.

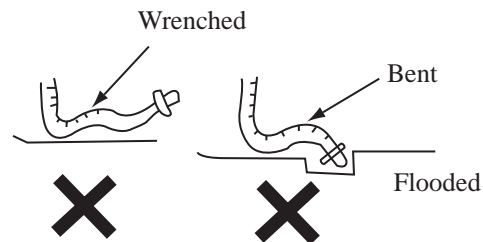

● Install the connection pipes

Connect the connection pipes with the relevant union pipes of the indoor unit (Shown in P27 “ Pipe connection”)

NOTE:

- Connect the connection pipes with the indoor unit firstly and the outdoor unit secondly.
- Be careful in bending the connection pipes, or you will damage the pipes.
- If the tightening torque is too great in tightening the flare nuts, leakage will happen.

● Electrical wiring

1. Open the surface panel.
2. Remove the wiring cover.
3. Route the power connection cord from the back of the indoor unit and pull it toward the front through the wiring hole for connection.
4. Connect the blue wire of the power connection cord to the terminal “ N(1)”, the brown one to “ 2”, the red one to “ 3”, and the yellow- green one (earth wire) to “ \oplus ” as shown in Fig.3.
5. Reassemble the wiring cover.
6. Recover the surface panel.

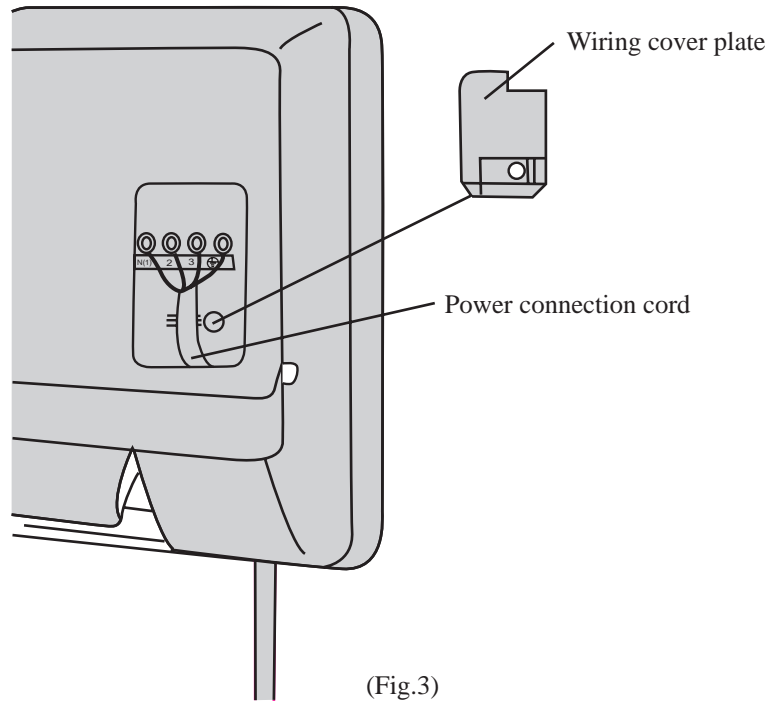

(Fig.3)

NOTE:

- All the electrical work must be done by qualified personnel according to the local rules and this manual.
- The rated voltage and the exclusive circuit must be used.
- Leakage circuit - breaker must be installed.
- Please use specified fuse.
- The diameter of power cord should be large enough. Use the exclusive wire to replace the damaged wire.
- Wiring work should conform to national standard.
- Switches shall be connected to the supply terminals and shall have a contact separation of at least 3mm in each pole.

● **Install the indoor unit**

1. When routing the piping and wiring from the left or right side of the indoor unit, cut off the tailings from the chassis in necessary (shown in Fig.4).

- ① Cut off the tailings1 when routing the wiring only.
- ② Cut off the tailings1 and tailings 2 when routing both the wiring and piping.

2. Wrap the piping and wiring and pull them through the cut-off -tailings hole (shown in Fig. 5).

3. Hang the 2 mounting slots of the indoor unit on the upper tabs of the real panel and check if it is firm enough.

4. The height of the installed location should be 2.3m or more from the floor.

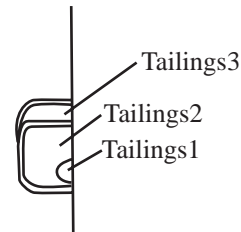

(Fig.4)

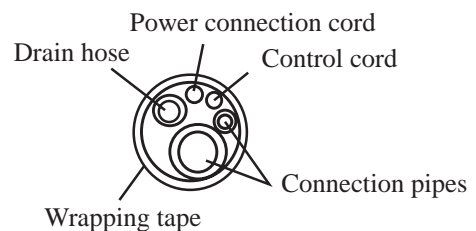

(Fig.5)

Install the outdoor unit

● Installing the unit

- BE Sure to fix unit's legs with bolts when installing it.
- Be sure to install the unit firmly to ensure that it does not fall by an earthquake or a gust.
- Refer to the figure in the right concrete foundation.

NOTE

The length of anchor bolts should be within 25mm from each anchor leg.

CAUTION:

Be sure to carry out drain piping work following the installation manual.

If there is some deficiency in draining and pinping work, it may cause a risk of dripping from the unit, wetting or fouling your property.

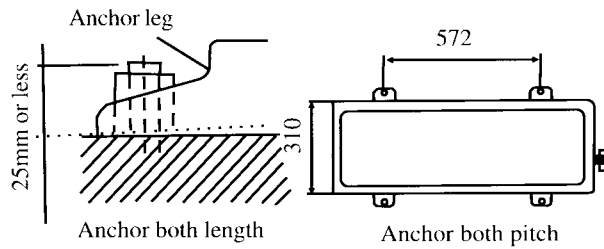
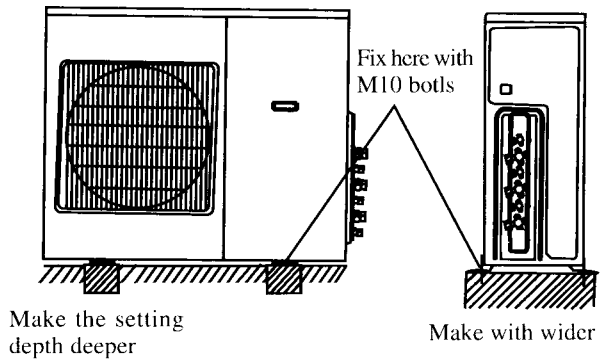

● How to remove the service panel

- Remove the four service panel securing screws, and pull the panel down in an arrow direction to remove the service panel.

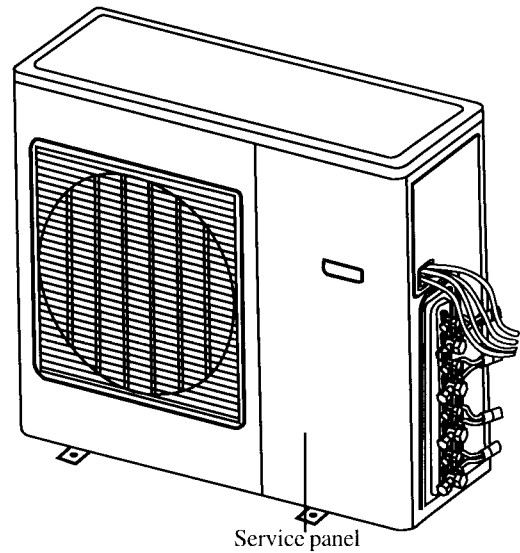

<Front view>

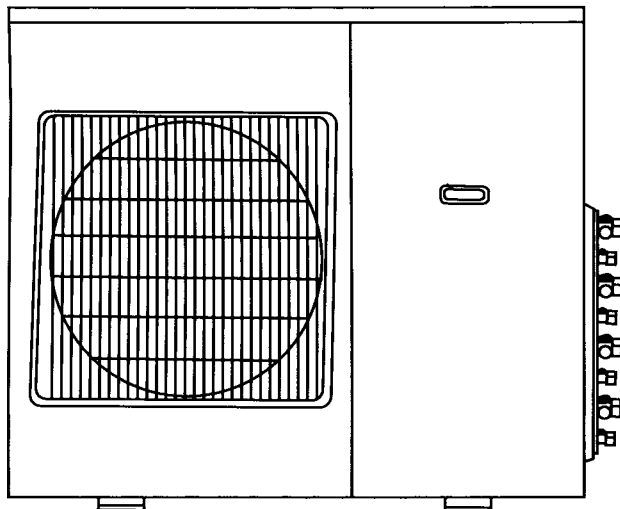

<Right side view>

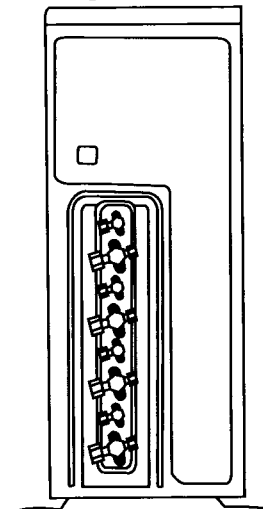

- Liquid A UNIT
- Gas B UNIT
- Liquid C UNIT
- Gas D UNIT

Indoor/outdoor wire connection and outdoor power supply cord connection

- Connect wire from the indoor unit correctly to the terminal block.
- For aftercare maintenance, give extra length to connecting wire.

	Indoor unit	Outdoor unit
Rated voltage	220 ~ 230V	220 ~ 230V
Breaker capacity	10A	25A
Power supply cord	4G1.0	3 × 2.5

Note: Be sure that the plastic square rings are tightly installed in the holes of the rear panel to protect the connection cords and the thermal insulation hose are tightly wrapped the connection cords near the rear panel in case of leakage of electricity and rain water.

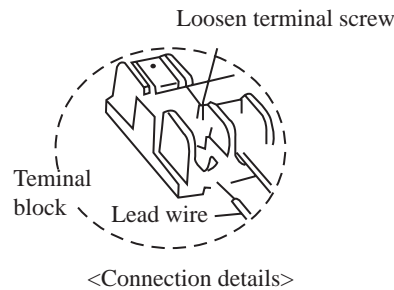

CAUTION:

- Be careful not to make mis-wiring.
- Firmly tighten the terminal screws to prevent them from loosening.
- After tightening, pull the wires lightly to confirm that they not move.
- If the connecting wire is incorrectly connected to the terminal block, the unit does not operate normally.
- Switches shall be connected to the supply terminals and shall have a contact separation of at least 3 mm in each pole.

WARNING:

Be sure to attach the terminal block covers/panel of the outdoor unit securely. if it is not attached correctly, it could result in fire or an electric shock due to dust, water, etc.

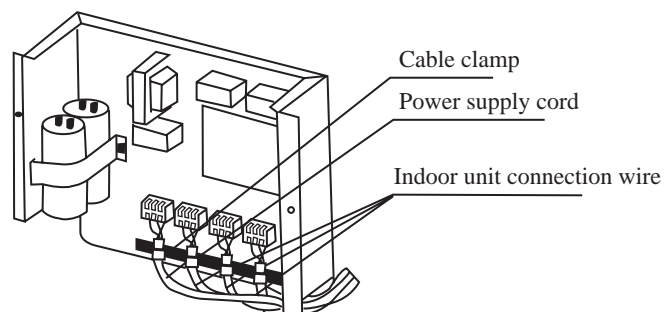

Indoor/outdoor units connection finishing and test run

● Pipe length and height difference

Limits				
UNIT NO.	A	B	C	D
pipe length per indoor unit	20 m max.	20 m max.	20 m max.	20 m max.
	Total 30 m max.		Total 30 m max.	
Height difference	10 m max.		10 m max.	
No.of bends	10 max.	10 max.	10 max.	10 max.
	Total 15 max.		Total 15 max.	

- Refrigerant adjustment... If pipe length exceeds 10 m, additional refrigerant (R22) charge is required. (The outdoor unit is charged with refrigerant for pipe length up to 10 m.)

A unit + B unit		C unit
Pipe length (one-way)	Refrigerant to be added	Refrigerant to be added
10 m or less	No additional charge	No additional charge
10-30m	10 g/m	10 g/m

- Indoor unit A and B or C and D are in the same refrigerant cycle system, so please add enough refrigerant to run both units A and B or C and D.

● Selecting pipe size

The diameter of connection pipes differs according to the type and the capacity of indoor units, Match the diameters of connection pipes for indoor and outdoor units according to the following table.

Valve size for outdoor unit.

Valve size for outdoor unit		
A UNIT	Liquid pipe	∅ 6.00 mm
	Gas pipe	∅ 9.52 mm
B UNIT	Liquid pipe	∅ 6.00 mm
	Gas pipe	∅ 9.52 mm
C UNIT	Liquid pipe	∅ 6.00 mm
	Gas pipe	∅ 9.52 mm
D UNIT	Liquid pipe	∅ 6.00 mm
	Gas pipe	∅ 9.52 mm

● Piping preparation

- ① Table below shows the specifications of pipes commercially available.

Pipe	Outside diameter	Insulation thickness	Insulation thickness
For liquid	∅ 6 mm	8 mm	Heat resisting foam plastic 0.045 specific gravity
For gas	∅ 9.52 mm	8 mm	

- ② Ensure that the 2 refrigerant pipes are insulated to prevent condensation.
- ③ Refrigerant pipe bending radius must be 100 mm or more.

CAUTION:

Be sure to use the insulation of specified thickness, Excessive thickness may cause incorrect installation of the indoor unit and lack of thickness may cause dew dripage.

Flaring work

Main cause of gas leakage is defect in flaring work.
 Perform flaring work correctly in the following procedure.

1. Pipe cutting

Cut the copper pipe correctly with pipe cutter.

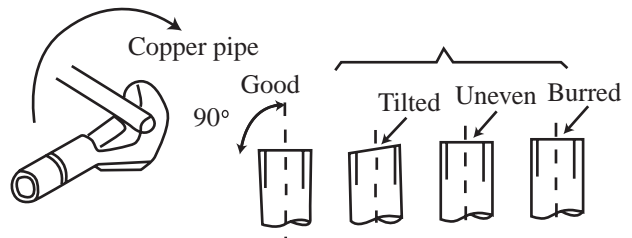

2. Burrs removal

Completely remove all burrs from the cut cross section of the pipe.

Put the end of the copper pipe downward to prevent burrs from dropping in the pipe.

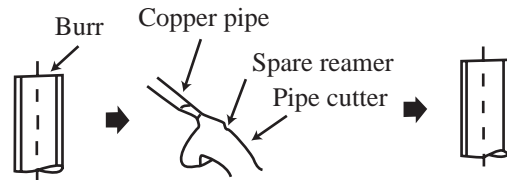

3. Putting nut on

Remove flare nuts attached to indoor and outdoor units, then put them on pipe having completed burr removal.

(not possible to put them on after flaring work)

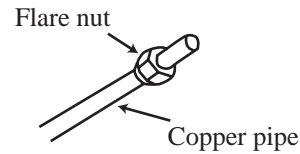

4. Flaring work

Perform flaring work using flaring tool as shown in the right.

Pipe diameter	A (mm)	For rigid
	For imperial	
Ø 6 mm	2.0 to 2.5	0.5
Ø 9.52 mm	3.0 to 3.5	0.5

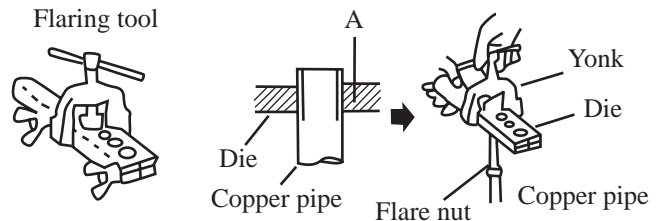

Firmly hold copper pipe in a die in the dimension shown in the table above.

5. Check

Compare the flared work with figure in the right.

If flare is noted to be defective, cut off the flared section and perform flaring work again.

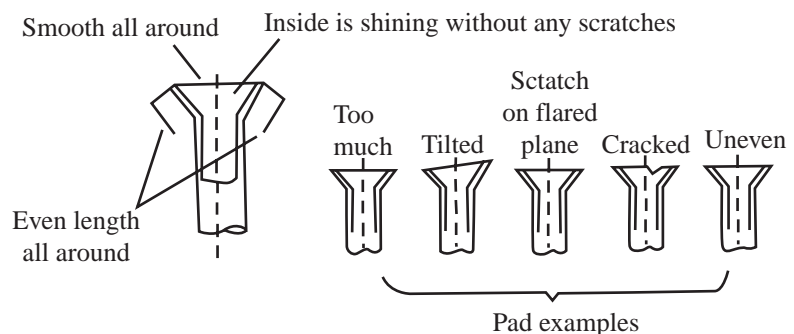

Pipe connection

① Indoor unit connection

Connect both liquid pipe and gas pipe to indoor unit.

Apply a thin coat of refrigeration oil to the seat surface of pipe.

For connection, align the center of both pipe and union, then tighten the first 3 to 4 turns in flare nut by hand.

For tightening the union part of the indoor unit side, use the table below as a standard and tighten the flare section.

Pipe diameter mm	Tightening torque	
	N.m	kgf.cm
6.35 mm	13.7 to 17.7	140 to 180
9.52 mm	34.3 to 41.2	350 to 420

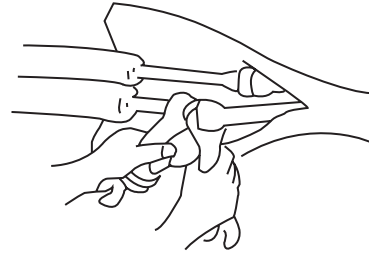

② Outdoor unit connection

Connect pipes to the pipe joint part of the stop valve in the same method as the indoor unit.

For tightening, use the same tightening torque applied for indoor unit and tighten the flare nut with torque wrench or spanner.

● Insulation and taping

① Cover piping joints with pipe cover.

② For outdoor unit side, surely insulate every piping including valves.

③ Using piping tape, apply taping starting from the entry of outdoor unit.

Fix the end of piping tape with adhesive tape.

When piping has to be arranged through above ceiling, closet or area where the temperature and humidity are high, wind additional commercially sold insulator for prevention of condensation.

Air purge and leak test

- For details about how to use manifold valves, see the instruction manual for manifold valves.
- The handle Hi below connect operate during the following work if it is fully closed.
- Evacuate every indoor unit for rooms A、 B、 C and D.

Make sure the pipes have been connected properly.

Connect the manifold valve to the service port of the stop valve (3- way valve) by using a charge hose, At this time, the inside-core end of the charge hose must be connected to the service port.

Make sure the stop valve (2-way and 3-way valve) are fully closed. and then connect another charge hose to a vacuum pump.

Fully open the handle Lo on the manifold valve, and then run the vacuum pump.
Loosen the flare nut of the stop valve (3-way valve) slightly to make sure that air is entering it.
Then, retighten the flare nut.
(If air is not entering it, make sure again the charge hose is firmly connected to the service port.)

Evacuate the circuit for 15 minutes or more, and make sure that the compound pressure gage reads-760 mm Hg.

After finishing the evacuation, fully close the handle Lo on the manifold valve. and then stop the vacuum pump.

Fully open the stop valve (2-way and 3-way valves) by turning the valve rods to the left until they stop When the rods contact the stoppers. do not apply force any more.

Tighten the valve rod caps for the stop valves (2-way and 3-way valves).

Leak test
Using soapy water. perform the leak test for both the indoor and outdoor sides, Make sure no bubbles appear on the connections. If bubbles appear they indicate gas is leaking from that point.

If gas is leaking
Tighten the flare nut connection more strongly.
If it has no effect, repair any existing leak points, release all gas from the service port completely, and then recharge the specified amount of refrigerant gas from cylinder.

	Tightening torque	
	N.m	kgf.cm
Cap for service port	13.7 to 17.7	140 to 180
Cap for stop valve	19.6 to 29.4	200 to 300

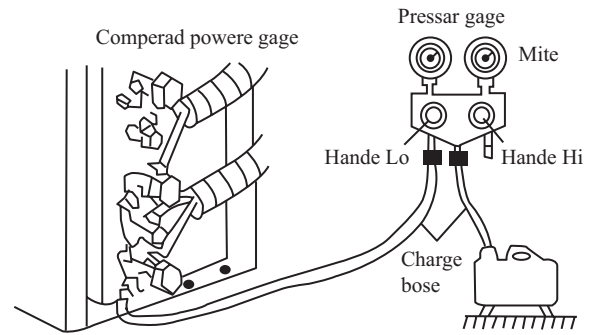

In the case of gas leakage

Tighten the flare nut connections.

If this tightening does not help stopping the leakage repair the leak portion (s). remove the gas from the service port, refill the specified amount from the cylinder gas.

WARNING:

When installing or moving the unit, do not mix anything other than specified refrigerant (R22) into the refrigerating cycle.

If air is mixed, it may cause the refrigerating cycle to get abnormally high temperature, causing a risk of burst.

For movement and maintenance

1 How to install the panel

- ① Before installing the panel, set the horizontal vane to the position as shown below.
- ② Insert the bottom of the panel under the horizontal vane.
- ③ Set the top of the panel.
- ④ Push the panel as the arrow mark to fix to the air conditioner.

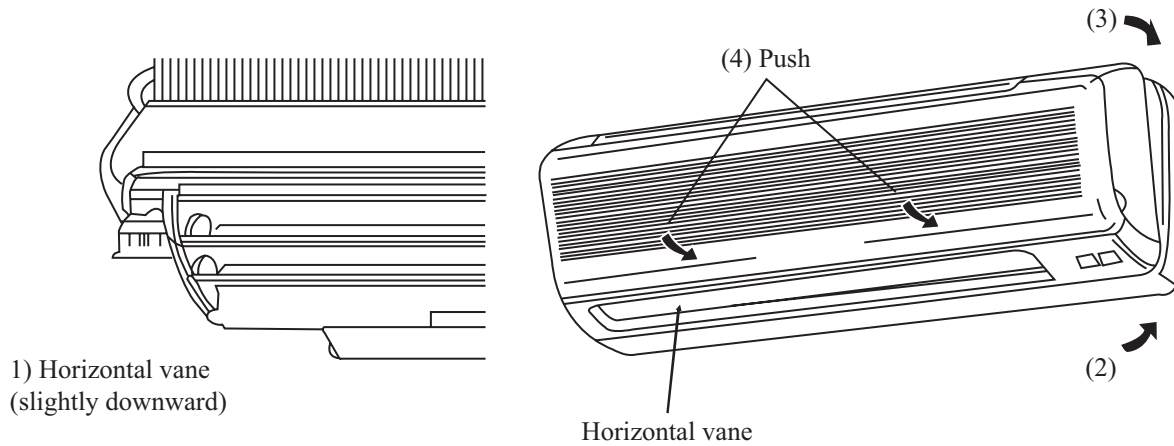

2 Removing the indoor unit

Remove the bottom of the indoor unit from the installation plate.

When releasing the corner part

Release both left and right bottom corner part of indoor unit and pull it downward and forward as shown toto release the hooks.

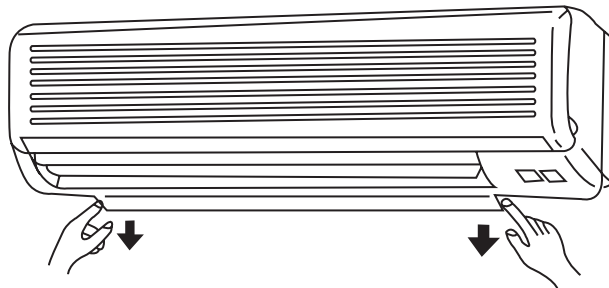

If the above method cannot be used

Remove the front panel and insert hexagonal wrenches into the square holes on the left and right as shot the figure below, then push them up; the bottom of the indoor unit is lowered and the hooks are released.

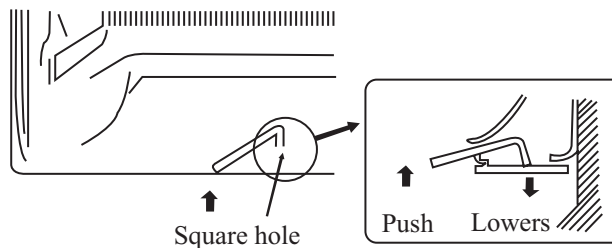

Gas charger

Perform gas charge to unit A or B and unit C or D

- ① Connect gas cylinder to the service port of stop valve.
- ② Perform air purge of the pipe (or hose) coming from refrigerant gas cylinder.
- ③ Replenish specified amount of the refrigerant, while operating the air conditioner for cooling.

CAUTION:

Never charge liquid refrigerant, such as by inverting the gas cylinder while charging, otherwise troubles may be generated. To maintain the high pressure of the gas cylinder, warm the gas cylinder with warm water (under 40 °C) during cold season, But never use naked fire or steam.

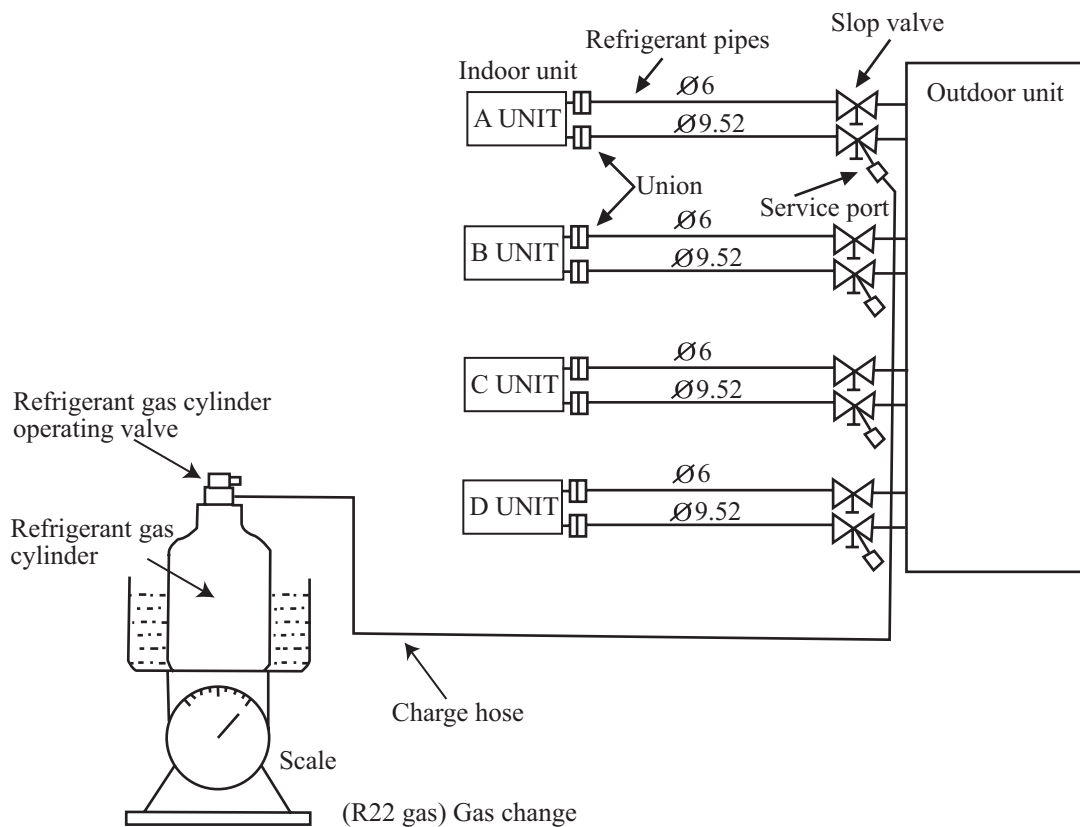

CONTENT

Operation and maintenance	The instructions before use		1	
	Name and function of each part		3	
	Remote Control operation procedure	Name and function-Remote control		4
		Name and function-Remote control (Remove the cover)		5
		COOL mode operation procedure		6
		DRY mode operation procedure		7
		AUTO mode operation procedure		8
		TIMER mode operation procedure		9
		SLEEP mode operation procedure		10
		HOW to insert batteries		11
	User notices		12	
	Care and Maintenance		13	
	Troubleshooting		15	
	Circuit diagram		17	
Installation	Accessories and installation diagram		18	
	Installation location		20	
	Install the indoor unit		21	
	Install the outdoor unit		23	
	Indoor/outdoor wire connection and outdoor power supply cord connection		24	
	Indoor/outdoor units connection finishing and test run		25	
	Flaring work		26	
	Pipe connection		27	
	Air purge and leak test		28	
	For movement and maintenance		29	
	Gas charger		30	

Thank you for choosing MUNDOCLIMA Air conditioner, please keep this owner's manual carefully for consultation.